

HuskyStar™

BY HUSQVARNA VIKING



USER'S GUIDE

C10/20

SYMBOL INSTRUCTIONS



Raise needle



Raise presser foot

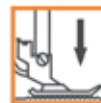

Lower presser foot

This household sewing machine is designed to comply with IEC/EN 60335-2-28 and UL1594

IMPORTANT SAFETY INSTRUCTIONS

When using an electrical appliance, basic safety precautions should always be followed, including the following:

Read all instructions before using this household sewing machine.

DANGER - To reduce the risk of electric shock:

- A sewing machine should never be left unattended when plugged in. Always unplug this sewing machine from the electric outlet immediately after using and before cleaning.
- Always unplug before relamping. Replace bulb with same type rated 5 Watt.

WARNING - To reduce the risk of burns, fire, electric shock, or injury to persons:

- Do not allow to be used as a toy. Close attention is necessary when this sewing machine is used by or near children or infirm person.
- Use this sewing machine only for its intended use as described in this manual. Use only attachments recommended by the manufacturer as contained in this manual.
- Never operate this sewing machine if it has a damaged cord or plug, if it is not working properly, if it has been dropped or damaged, or dropped into water. Return the sewing machine to the nearest authorised dealer or service center for examination, repair, electrical or mechanical adjustment.
- Never operate the sewing machine with any air openings blocked. Keep ventilation openings of the sewing machine and foot control free from the accumulation of lint, dust, and loose cloth.
- Keep fingers away from all moving parts. Special care is required around the sewing machine needle.
- Always use the proper needle plate. The wrong plate can cause the needle to break.
- Do not use bent needles.
- Do not pull or push fabric while stitching. It may deflect the needle causing it to break.
- Switch the sewing machine off ("0") when making any adjustment in the needle area, such as threading needle, changing needle, threading bobbin, or changing presser foot, etc.
- Always unplug the sewing machine from the electrical outlet when removing covers, lubricating, or when making any other user servicing adjustments mentioned in the instruction manual.
- Never drop or insert any object into any opening.
- Do not use outdoors.
- Do not operate where aerosol (spray) products are being used or where oxygen is being administered.
- To disconnect, turn all controls to the off ("0") position, then remove plug from outlet.
- Do not unplug by pulling on cord. To unplug, grasp the plug, not the cord.

SAVE THESE INSTRUCTIONS

CONTENTS

PRINCIPAL PARTS OF THE MACHINE	7
BUTTONS OF THE MACHINE	8
LCD SCREEN - MODEL C10	10
LCD SCREEN - MODEL C20	11
PATTERN CHART - MODEL C10.....	12
PATTERN CHART - MODEL C20.....	13
ACCESSORIES	14
CONNECTING THE MACHINE TO THE POWER SOURCE	15
START SEWING	16
Speed adjustment lever.....	16
Foot control	16
REPLACING THE NEEDLE	17
CHANGING THE PRESSER FOOT	17
Attaching the presser foot holder	17
Attaching the presser foot	17
Removing the presser foot	17
Attaching the seam guide	17
ADJUSTING PRESSER FOOT PRESSURE	18
MATCHING NEEDLE/ FABRIC/ THREAD	18
TYPE OF PRESSER FOOT CHART	19
WINDING THE BOBBIN	20
INSERTING THE BOBBIN	22
THREADING THE UPPER THREAD	23
NEEDLE THREADER	25
TOP THREAD TENSION	26
BRINGING UP THE BOBBIN THREAD	27
CUTTING THE THREAD	27
PRESSER FOOT LIFT	28
RAISE OR LOWER THE FEED DOGS	28
OPERATION BUTTONS	29
Reverse button	29
Auto-lock button	30
Needle up/down button	30
FUNCTION BUTTONS	31
Stitch width button	31
Stitch length button.....	32
MODE selection button	32
Pattern mirroring button	33
SELECTION BUTTONS	34
Direct pattern selection buttons.....	34
Number buttons	34
MEMORY BUTTONS	35

Memory button	35
Clear button	35
Arrow button	35
USEFUL SKILLS	36
Sewing corners.....	36
Reverse	36
Free arm	36
Sewing on heavy fabric	37
STRAIGHT STITCHES AND NEEDLE POSITION.....	38
Changing the needle position.....	38
Changing the stitch length.....	38
ZIGZAG STITCHES	38
Adjusting the stitch width.....	38
Adjusting the stitch length	38
STRETCH STITCH.....	39
OVERCASTING STITCHES	40
Using the overcasting foot.....	40
Using the standard foot	40
BLINDHEM.....	41
BUTTON SEWING	42
BUTTONHOLE STITCHING	43
Making a buttonhole on stretch fabrics.....	46
EYELET STITCH.....	47
DARNING STITCH.....	48
ZIPPER INSERTION.....	50
Inserting a centered zipper	50
QUILTING.....	51
FREE-MOTION, DARNING, EMBROIDERY AND MONOGRAMMING	52
Darning	52
Embroidery	53
Monogramming	53
MIRRORING	54
MEMORY - MODEL C10.....	55
Program patterns.....	55
Add patterns	56
Clear patterns	56
Recall and sew the programmed pattern	57
MEMORY - MODEL C20.....	58
Program patterns.....	58
Add patterns or letters	59
Clear patterns or letters.....	59
Recall and sew the programmed pattern	60
WARNING FUNCTIONS	61

Warning animation message display	61
Instruction animation message display	61
Warning beeping sound.....	61
REPLACING THE LIGHT BULB	62
MAINTENANCE	63
Cleaning the screen	63
Cleaning the sewing machine surface.....	63
Cleaning the hook	63
TROUBLESHOOTING GUIDE.....	65
QUICK REFERENCE CHART - MODEL C10	67
QUICK REFERENCE CHART - MODEL C20	69

PRINCIPAL PARTS OF THE MACHINE

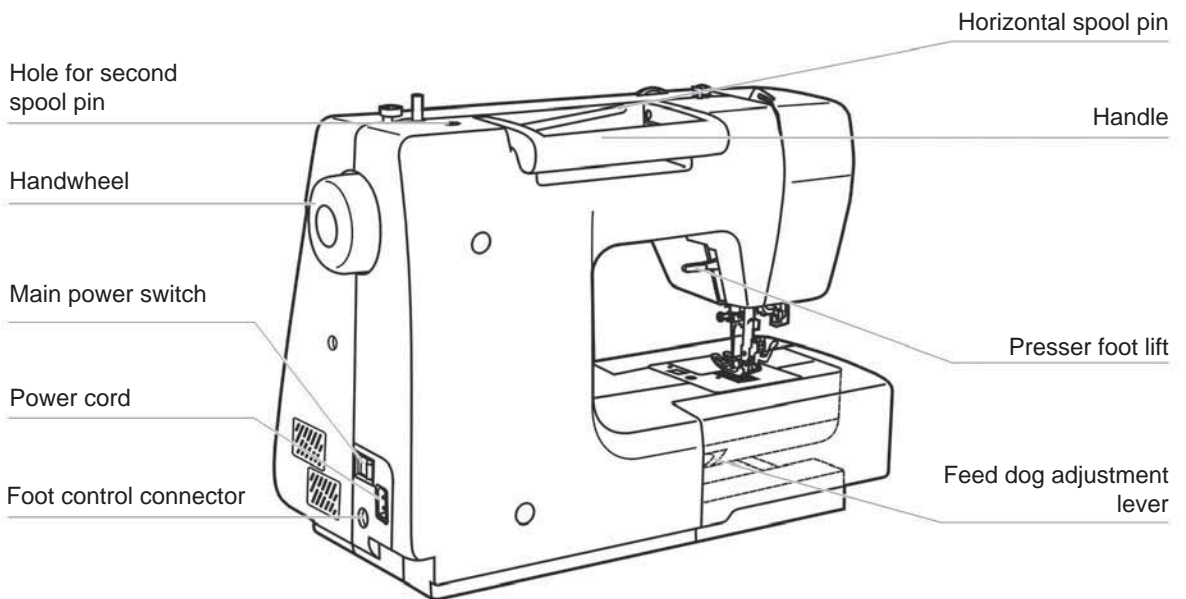
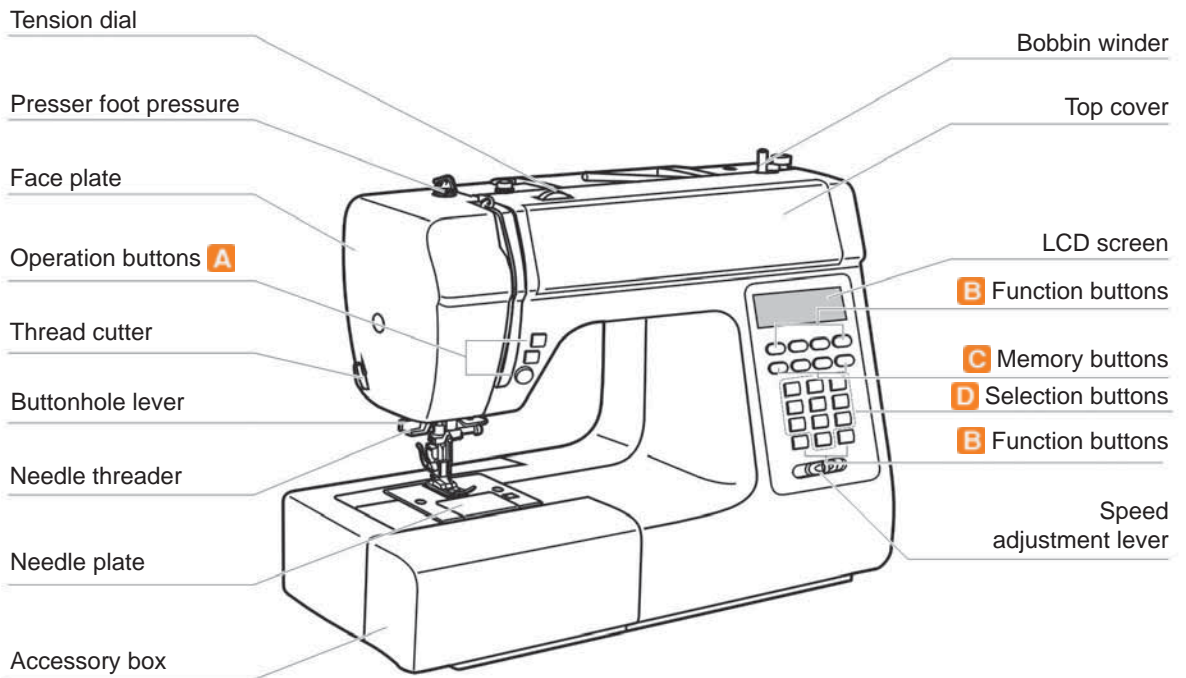

BUTTONS OF THE MACHINE

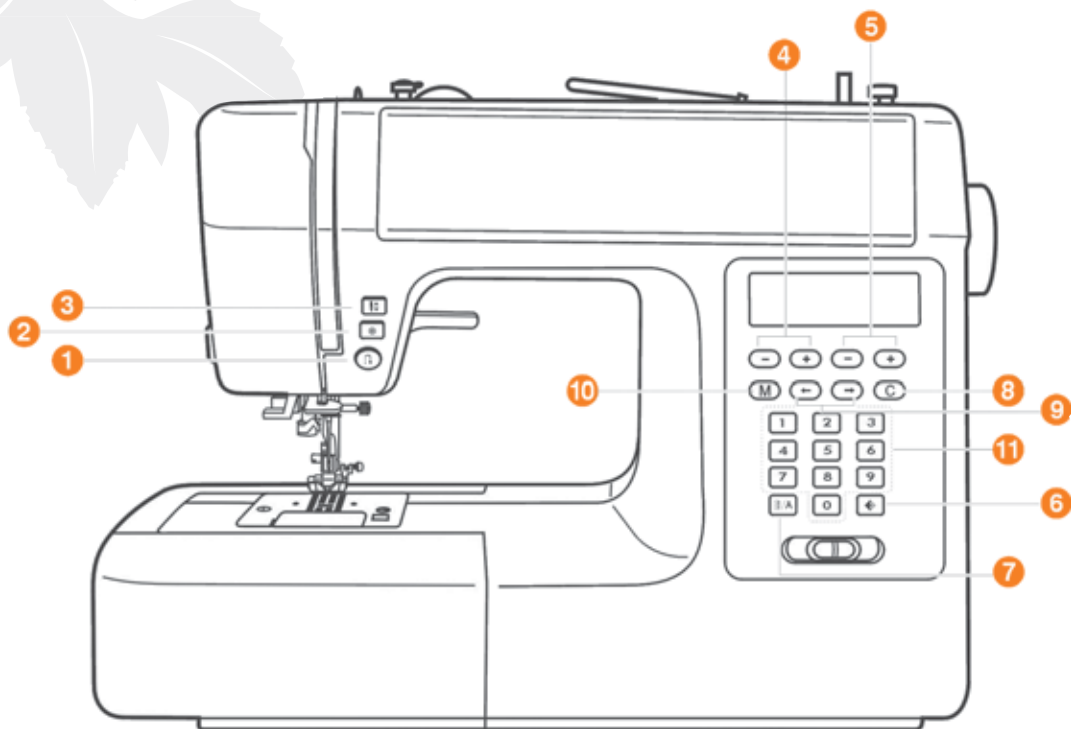

A. Operation buttons

1. Reverse button

Hold down this button to sew either backwards or a reinforcement stitch at a low speed.

2. Auto-lock button

Hold down this button to sew locking stitches immediately or at the end of the current pattern and automatically stop.

3. Needle up/down button

Press this button to move the needle either up or down.

B. Function buttons

4. Stitch length

Press this button to adjust the length of the stitch.

5. Stitch width

Press this button to adjust the width of the stitch.

6. Pattern mirroring

Press this button to sew a mirrored pattern.

7. Mode selection



Press this button to select direct mode, utility and decorative pattern mode or block letter mode.

C. Memory buttons

8. Clear button

If an incorrect pattern is selected or programmed, pressing this button will clear it.

9. Arrow button

Press the “” button or “” button until the desired stitch number in the programmed combination is displayed.

10. Memory button

Press this button to enter or store the programmed pattern combination in the memory.

D. Selection buttons

11. Direct pattern selection and number buttons

Instant access to direct pattern or press the pattern number to select the desired pattern.

LCD SCREEN - MODEL C10

Direct Pattern

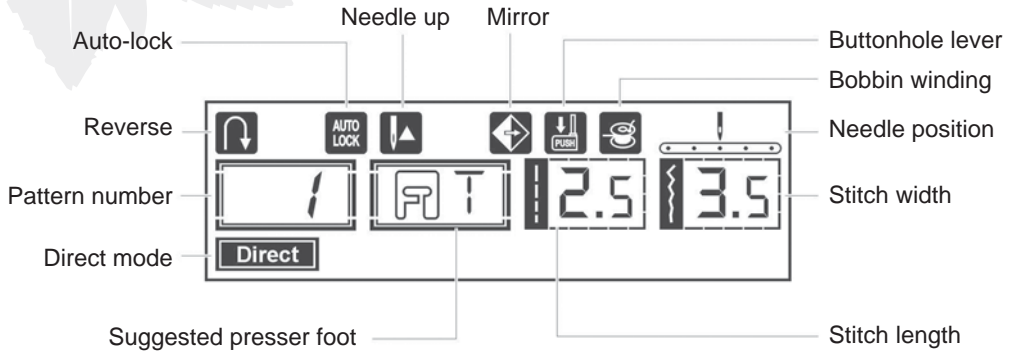

Pattern

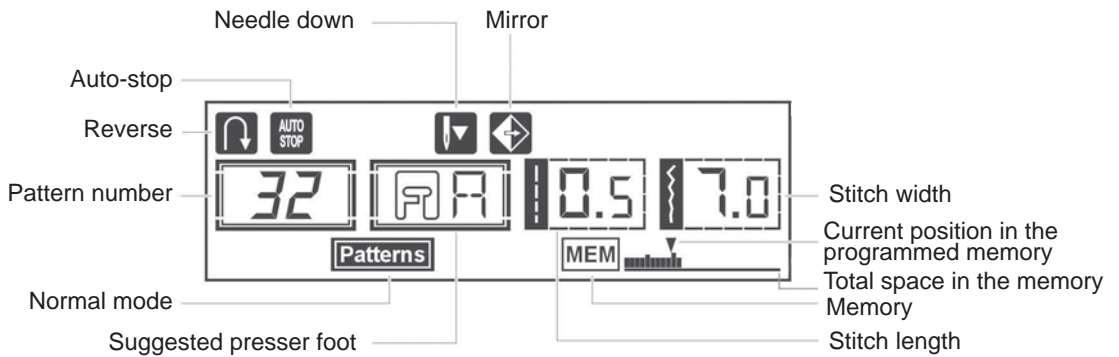

LCD SCREEN - MODEL C20

Direct Pattern

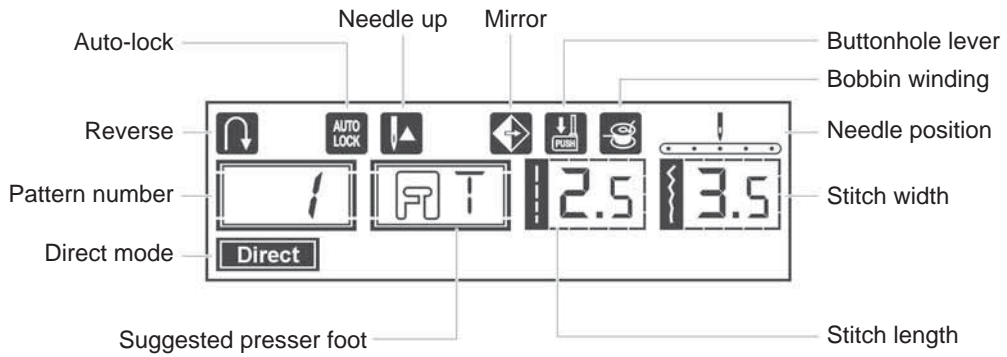

Pattern

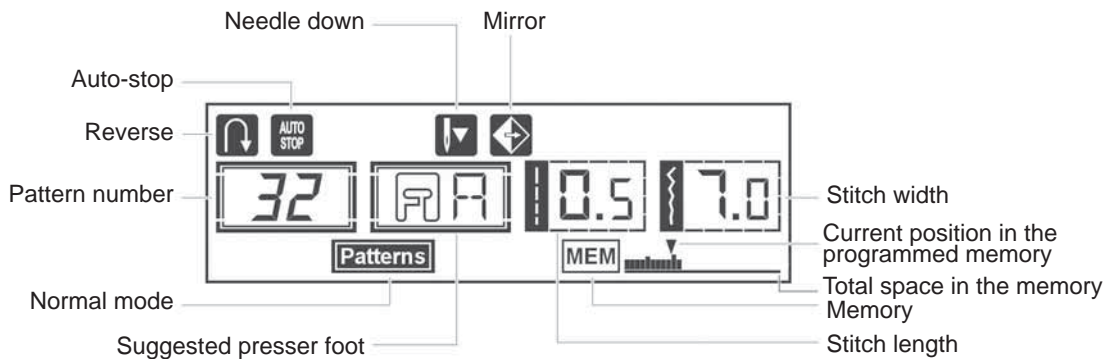

Alphabet

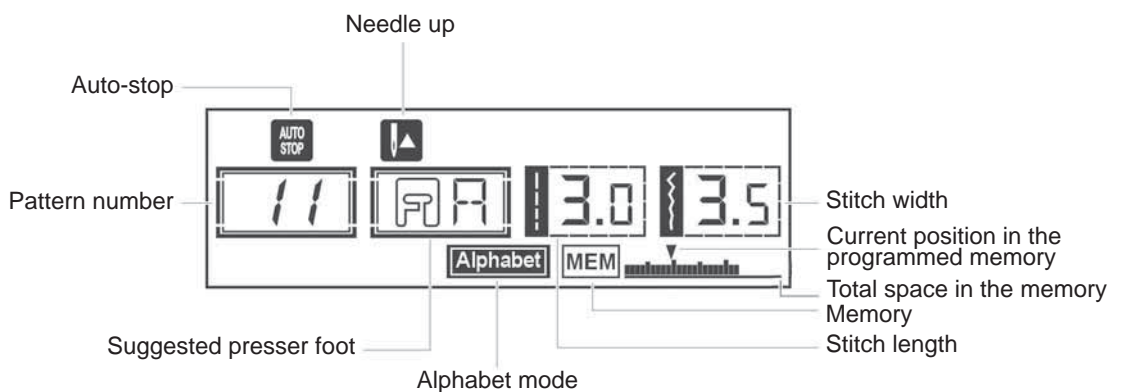

PATTERN CHART - MODEL C10

The portion marked in color on the chart below shows the one unit of each pattern.

A. Direct selection patterns



B. Pattern selection by number

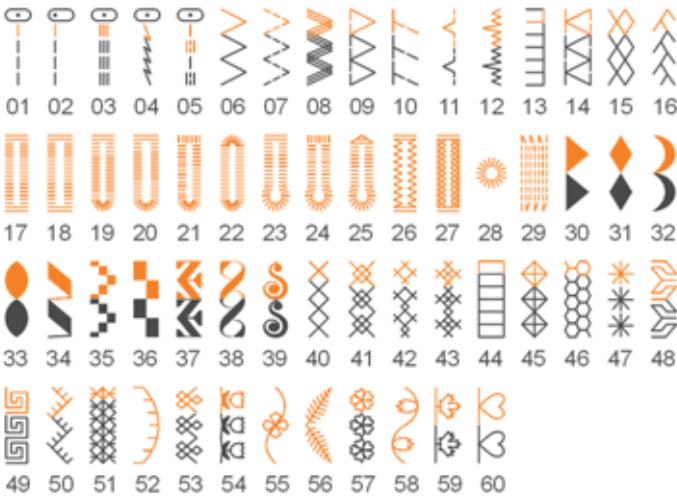

PATTERN CHART - MODEL C20

The portion marked in color on the chart below shows the one unit of each pattern.

A. Direct selection patterns



B. Pattern selection by number

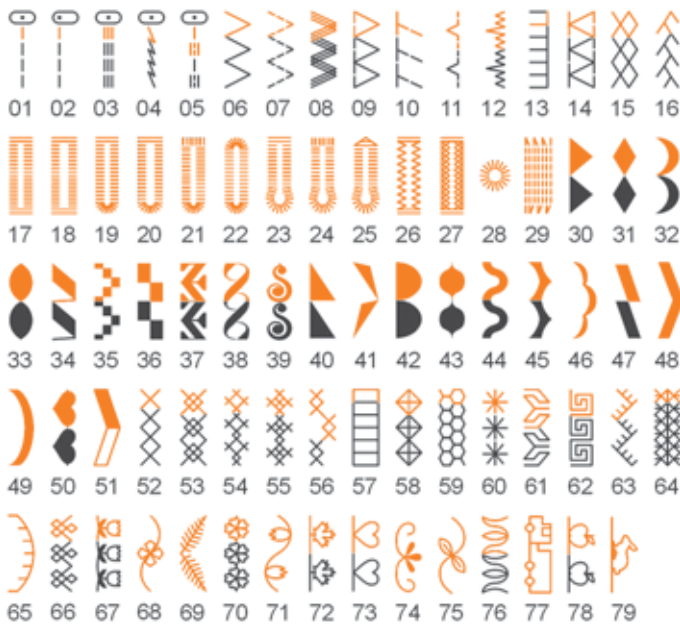

C. Alphabets



ACCESSORIES

1. Standard foot (T)
2. Zipper foot (I)
3. Buttonhole foot (D)
4. Overcasting foot (E)
5. Blindhem foot (F)
6. Satin stitch foot (A)
7. Button sewing foot (only for C20).
8. 1/4" Quilting foot (P)
9. Free-motion/darning foot
10. Pack of needles
11. Spool pin felt
12. Second spool pin
13. Brush/ Seam ripper
14. Spool cap (Large)
15. Spool cap (Small)
16. Seam guide
17. Bobbins
18. Screwdriver (L & S)
19. Hard cover

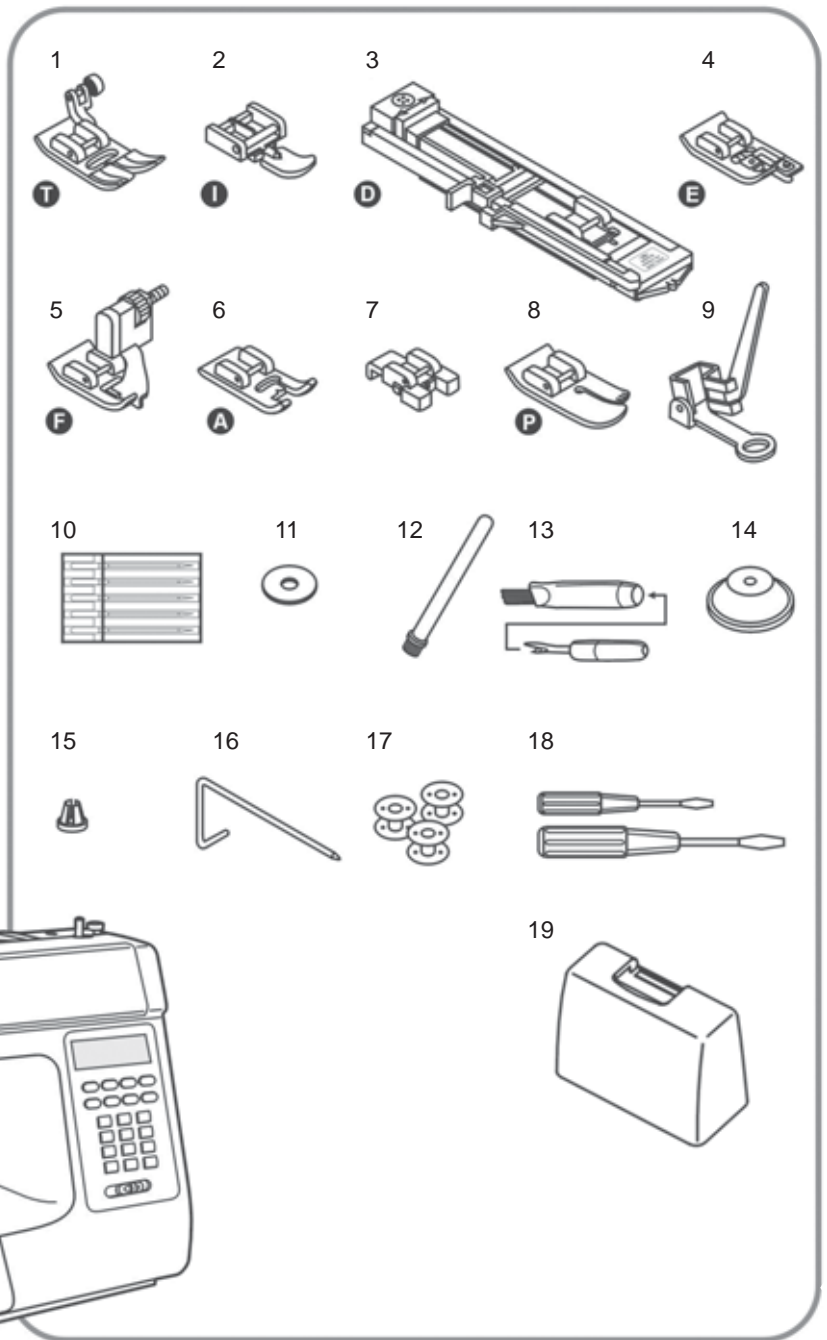

CONNECTING THE MACHINE TO THE POWER SOURCE

 **Caution:** Always make sure that the machine is unplugged from power source and the main switch is on “O” when the machine is not in use and before inserting or removing parts.

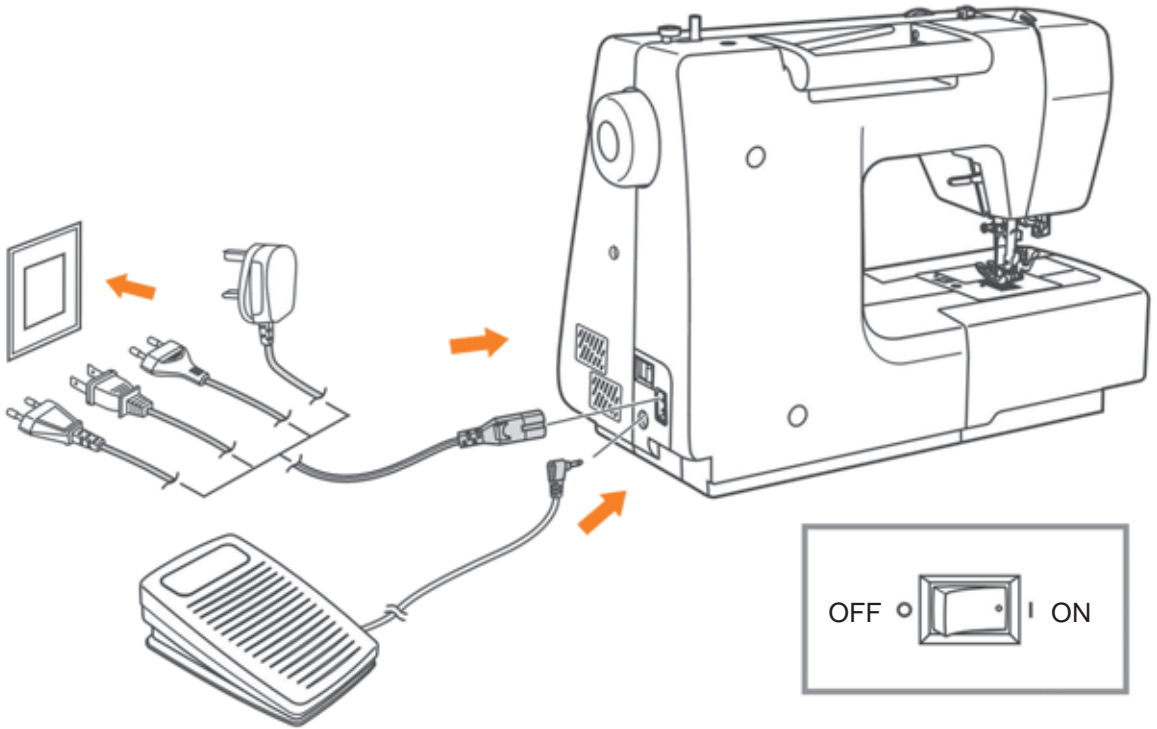

Before connecting the power supply, make sure that the voltage and frequency shown on the machine is conforming with your electrical power.

Place the machine on a stable table.

1. Connect the power line cord to the machine by inserting the 2-hole plug into the terminal box.
2. Connect the power line plug to the electric outlet.
3. Turn on the power switch.
4. The light bulb will light up when the switch is turned on.

To disconnect, turn the power switch to the off position, then remove plug from outlet.

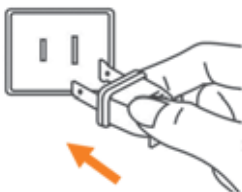

For USA and Canada

This appliance has a polarized plug (one blade wider than the other), to reduce the risk of electrical shock; this plug will fit in a polarized outlet only one way. If the plug does not fit fully in the outlet, reverse the plug. If it still does not fit, contact a qualified electrician. Do not modify the plug in any way.

STARTING SEWING

Speed adjustment lever

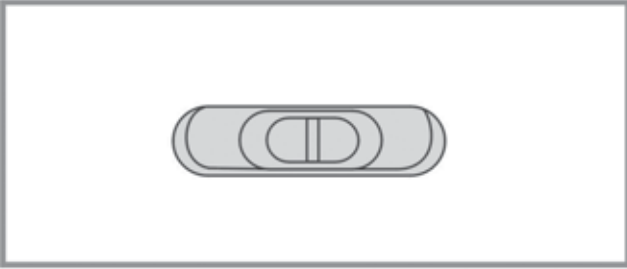

The speed adjustment lever can control the sewing speed. To increase the speed, slide the lever to right. To decrease the sewing speed, slide the lever to the left.

Foot control

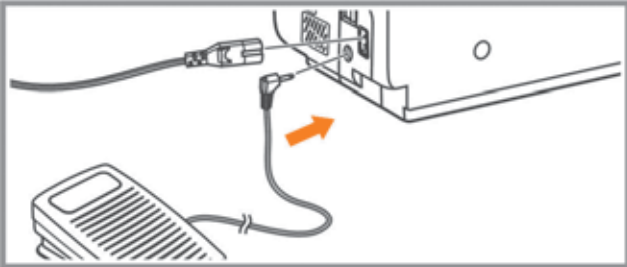

With the sewing machine turned off, insert the foot control plug into its connector on the sewing machine.

Turn on the sewing machine, and then slowly depress the foot control to start sewing.

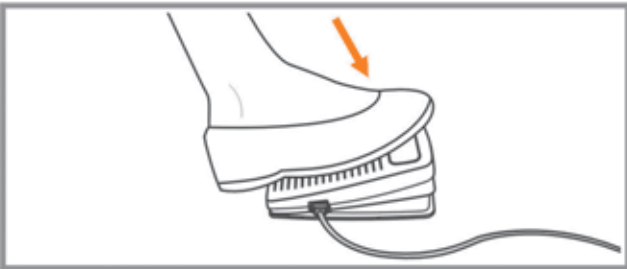

Release the foot control to stop the sewing machine.



Attention: Consult a qualified electrician if in doubt as how to connect the machine to the power source. Unplug the power cord when the machine is not in use.

The appliance must be used with the foot controller C-9000.

REPLACING THE NEEDLE

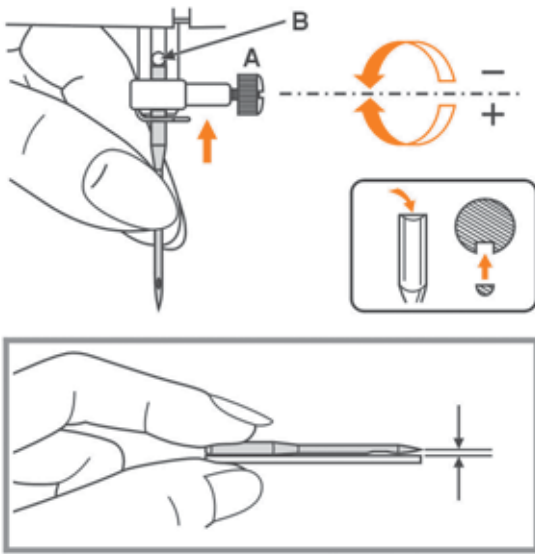

⚠ Attention: Turn power switch to off (“O”) when carrying out any of the operations below!

Change the needle regularly, especially if it is showing signs of wear and causing problems. Insert the needle following the illustrated instructions.

- A. Loosen the needle clamp screw and tighten again after inserting the new needle.
The flat side of the shaft should be towards the back.
- B. Insert the needle as far up as it will go.

Needles must be in perfect condition. Problems can occur with:

- Bent needles
- Blunt needles
- Damaged points

CHANGING THE PRESSER FOOT

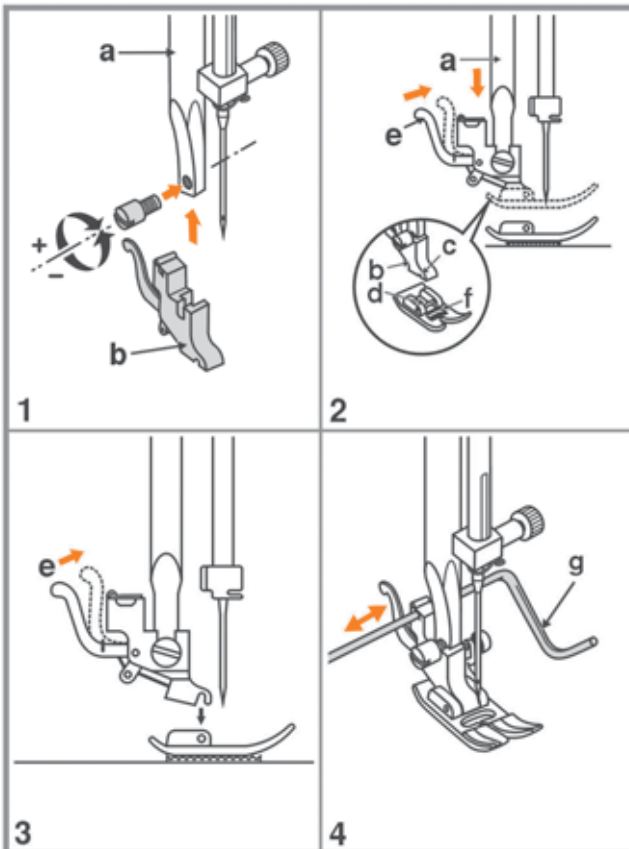

⚠ Attention: Turn power switch to off (“O”) when carrying out any of the operations below!

Attaching the presser foot holder (1)

Raise the presser foot bar (a). Attach the presser foot holder (b) as illustrated.

Attaching the presser foot (2)

Lower the presser foot holder (b) until the cut-out (c) is directly above the pin on the foot (d).

Raise the lever (e).

Lower the presser foot holder (b) and the presser foot (f) will engage automatically.

Removing the presser foot (3)

Raise the presser foot.

Raise the lever (e) and the foot will disengage.

Attaching the seam guide (4)

Attach the seam guide (g) in the slot as illustrated. Adjust according to need for hems, pleats, quilting etc.

ADJUSTING PRESSER FOOT PRESSURE

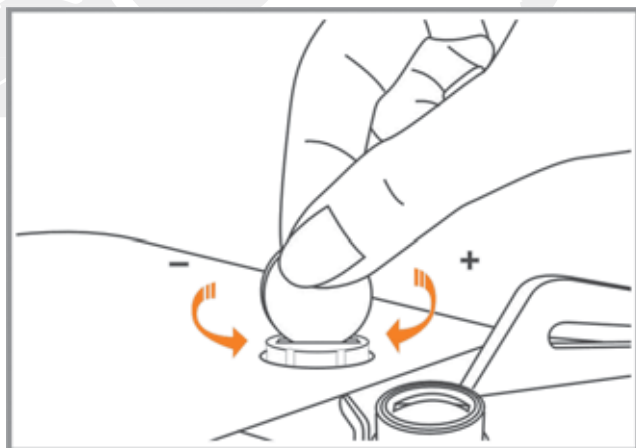

The presser foot pressure of the machine has been pre-set and requires no adjustment for most fabric weights.

However, if you choose to adjust the presser foot pressure, turn the presser adjusting screw with a coin.

For sewing very heavy fabric, loosen the pressure by turning the screw counter clockwise, and for thin fabric, tighten by turning it clockwise.

MATCHING NEEDLE/ FABRIC/ THREAD













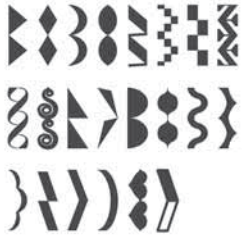

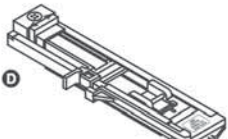
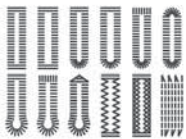
NEEDLE, FABRIC, THREAD SELECTION GUIDE		
NEEDLE SIZE	FABRICS	THREAD
9-11 (70-80)	Lightweight fabrics-thin cottons, voile, silk, muslin, interlocks, cotton knits, tricot, jerseys, crepes, woven polyester, shirt & blouse fabrics.	Light-duty thread in cotton, nylon, polyester or cotton wrapped polyester.
11-14(80-90)	Medium weight fabrics-cotton, satin, sailcloth, double knits, lightweight wool.	Most threads sold are medium size and suitable for these fabrics and needle sizes. Use polyester threads on synthetic materials and cotton on natural woven fabrics for best results. Always use the same thread on top and bottom.
14 (90)	Medium weight fabrics-cotton duck, wool, heavier knits, terrycloth, denims.	
16 (100)	Heavyweight fabrics-canvas, wool, outdoor tent and quilted fabrics, denims, upholstery material (light to medium).	
18 (110)	Heavy wool, overcoat fabrics, upholstery fabrics, some leathers and vinyls.	Heavy duty thread, carpet thread.



Please Note:

- In general, fine threads and needles are used for sewing fine fabrics, and thicker threads are used for sewing heavy fabrics.
- Always test thread and needle size on a small piece of fabric which will be used for actual sewing.
- Use the same thread for needle and bobbin.

TYPE OF PRESSER FOOT CHART

PRESSER FOOT	APPLICATION	PRESSER FOOT	APPLICATION
 <p>Standard foot (T)</p>	<p>General sewing, Patchwork stitches, Decorative stitching, Smocking, Fagoting, etc.</p>	 <p>Satin stitch foot (A)</p>	<p>Satin stitch</p> 
 <p>Zipper foot (I)</p>	<p>Inserting zippers</p> 		
 <p>Buttonhole foot (D)</p>	<p>Buttonhole sewing</p> 	 <p>1/4" Quilting foot (P)</p>	<p>Quilting</p> 
 <p>Overcasting foot (E)</p>	<p>Overcasting</p> 	 <p>Free-motion/darning foot</p>	<p>Free-motion, Darning, Embroidery, Monogramming</p> 
 <p>Blindhem foot (F)</p>	<p>Blindhem stitching</p> 	 <p>Button sewing foot (model C20 only)</p>	<p>Button sewing</p> 

WINDING THE BOBBIN

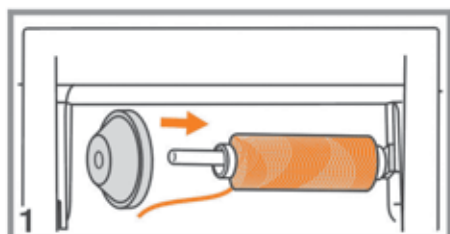
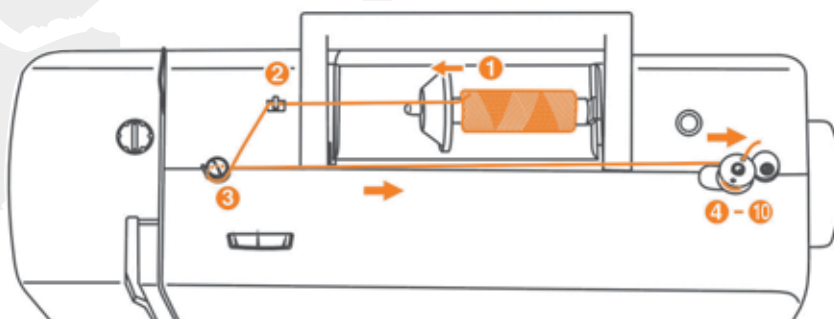

1. Place the thread and spool cap onto the spool pin.
For smaller spools of thread, place spool cap with the small side next to the spool or use the small spool cap.

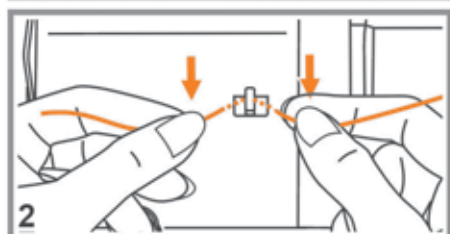

2. Snap the thread into the thread guide.

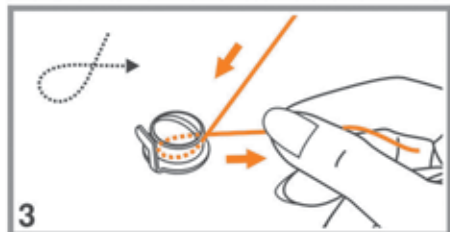

3. Wind the thread clockwise around the bobbin winder tension discs.

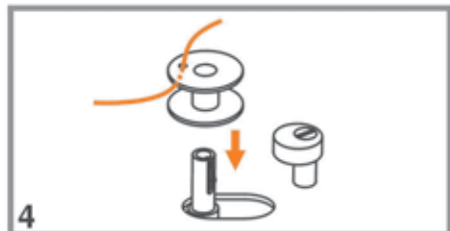

4. Place the thread end through one of the inner holes in the bobbin as illustrated and place the empty bobbin on the spindle.

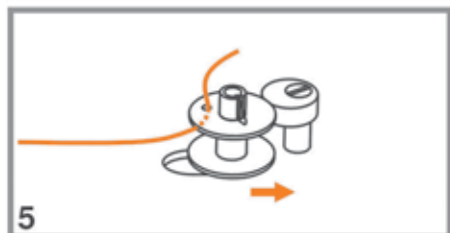

5. Hold on to the thread tail and push the bobbin to the right.

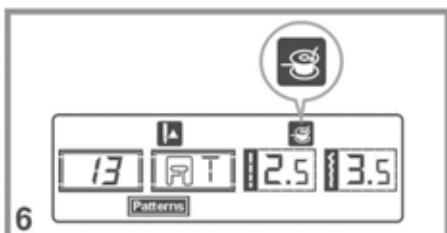

6. When the bobbin winder spindle is pushed to the right, “bobbin winding position”, the symbol “” is shown on the LCD screen.
It will disappear from the LCD screen when the bobbin winder spindle is push to the left, “sewing position”.

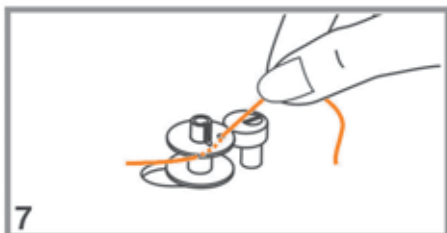

7. Hold the thread tail securely in one hand.



8. Press on the foot control to start the sewing machine.

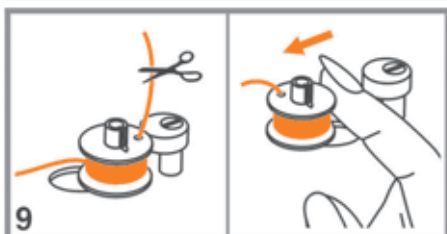

9. After the bobbin has wound a few turns stop the machine and cut the thread near the hole of the bobbin. Continue filling the bobbin until it is full. The motor stops automatically when the bobbin is full. Stop the machine. Push the bobbin winder spindle to left.

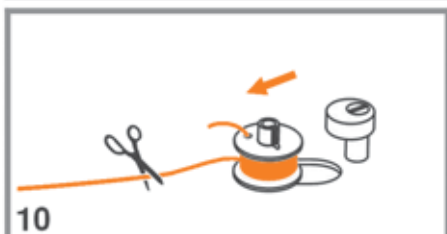

10. Cut the thread and then remove the bobbin.



Please Note: When the bobbin winder switch is pushed to the right, “bobbin winding position”, the machine will not sew and the handwheel will not turn. To start sewing, push the bobbin winder switch to the left “sewing position”.

INSERTING THE BOBBIN

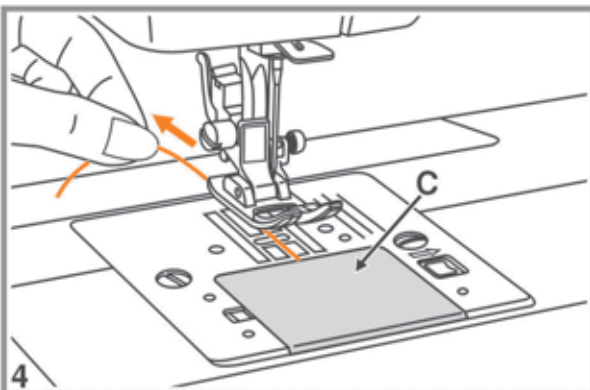
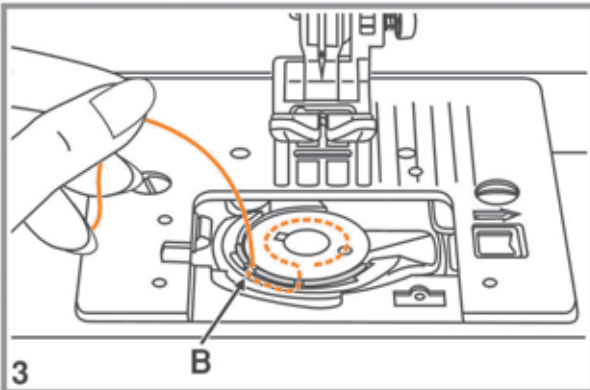
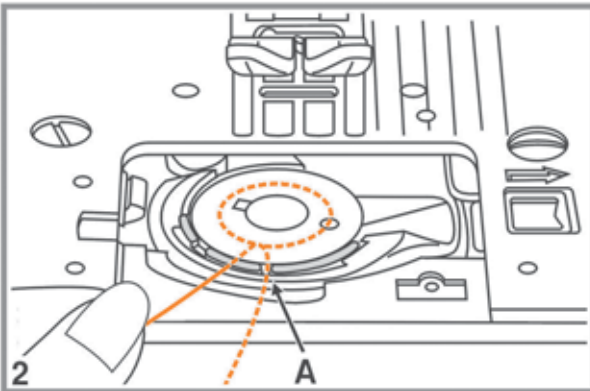
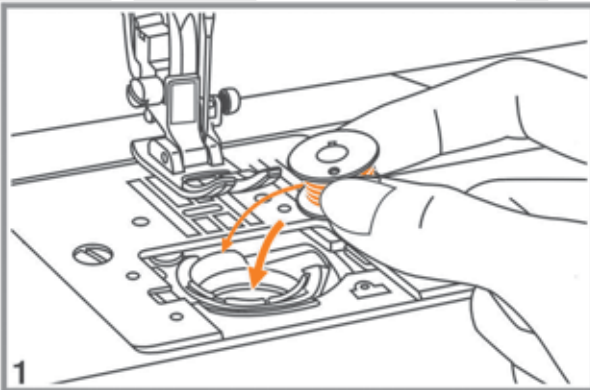

Attention: Turn power switch to off (“O”) before inserting or removing the bobbin.

When inserting or removing the bobbin, the needle must be fully raised.

1. Remove the bobbin cover and insert the bobbin in the bobbin case with the thread running in a counterclockwise direction (arrow).

2. Pull the thread through the slit (A).

3. Pull the thread toward the left and along the inside of the spring until it slips into the notch (B) being sure that the thread does not slip out of the slit (A).

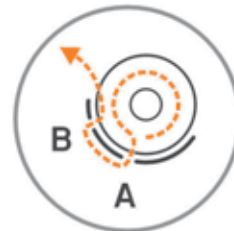

4. Pull out about 15 cm (6 inches) of thread and slide on the bobbin cover. (C)



THREADING THE UPPER THREAD

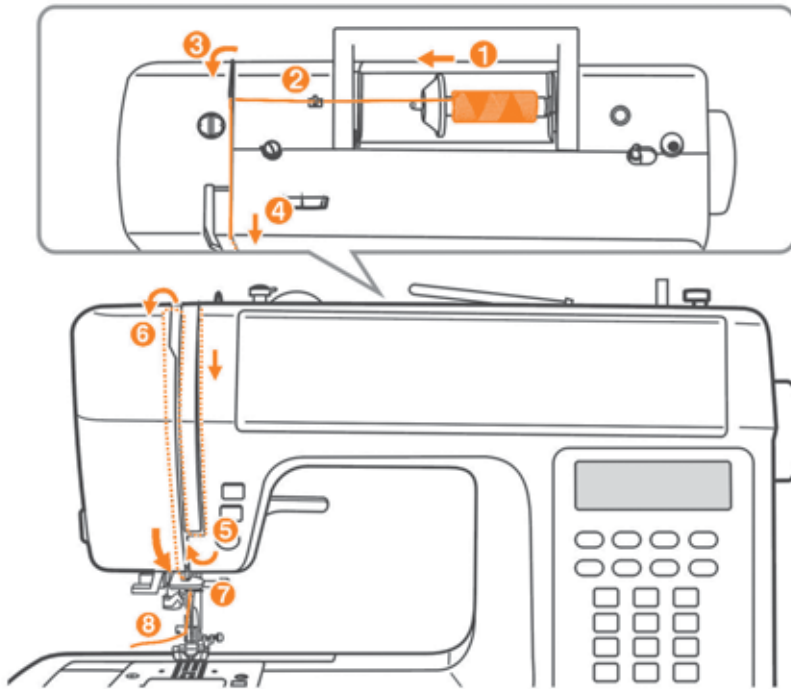

Please Note: It is important to thread correctly to prevent sewing problems.

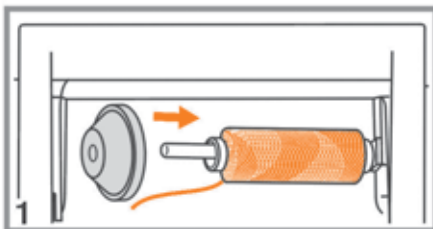

Start by raising the needle to its highest point, by turning the hand wheel toward you. Raise the presser foot lift to open the tension discs.

1. Lift up the spool pin. Place the spool of thread on the spool pin so that the thread comes from the front of the spool, then place the spool cap at the end of the spool pin.

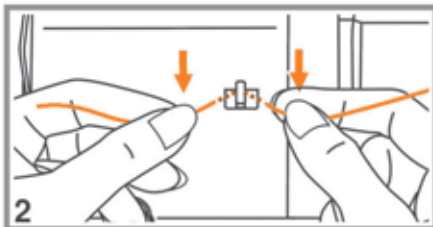

2. Pull the thread from the spool through the upper thread guide.

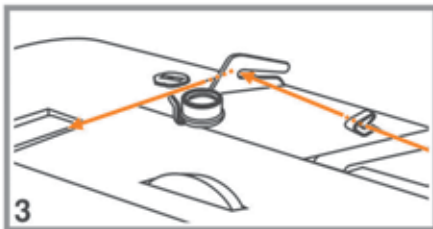

3. Guide the thread around the thread guide pulling the thread through the pre-tension spring as illustrated.

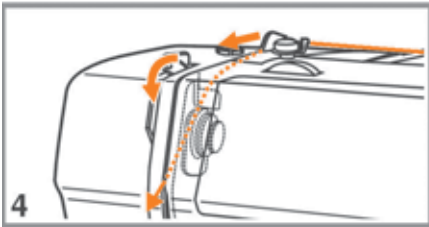

4. Pull the thread down between the tension discs.

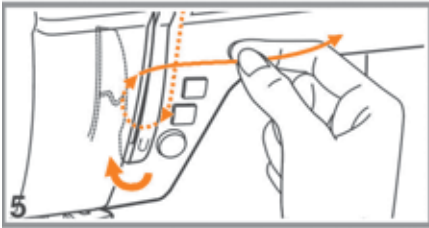

5. Then, down and around the check spring holder and back up to the take up lever.

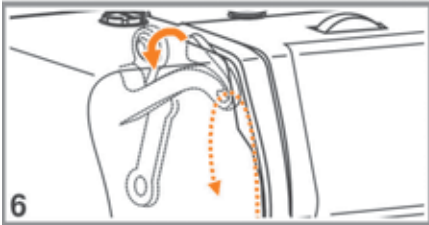

6. Pull the thread from right to the left through the slotted eye of the take-up lever and then down again.

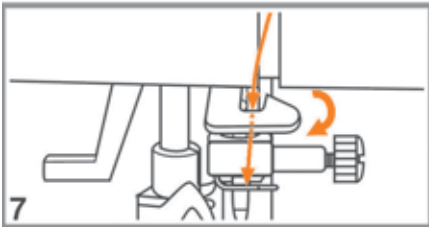

7. Pass the thread behind the flat, horizontal thread guide.

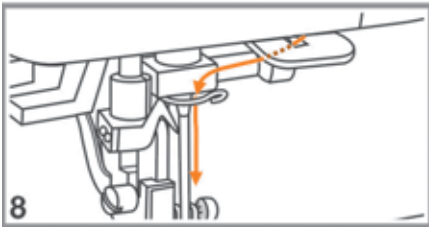

8. Guide the thread into the wire loop.

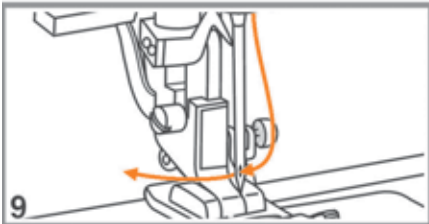

9. Thread the end of the thread through the needle from front to back, and pull out about 10 cm of thread.
Or use the needle threader to thread the needle. (On the next page).

NEEDLE THREADER

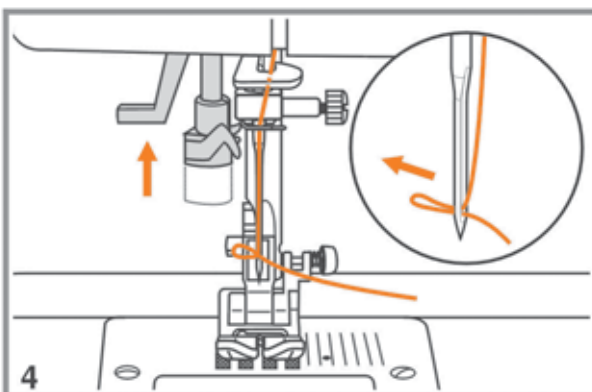
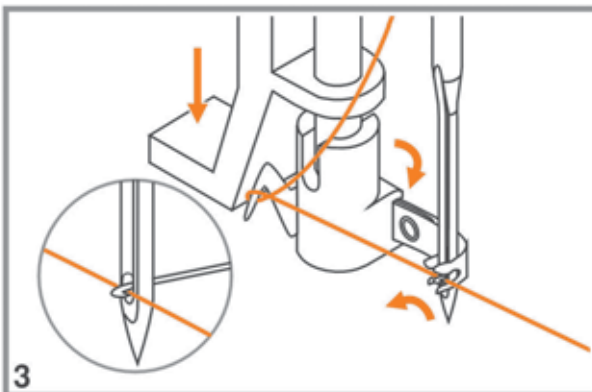
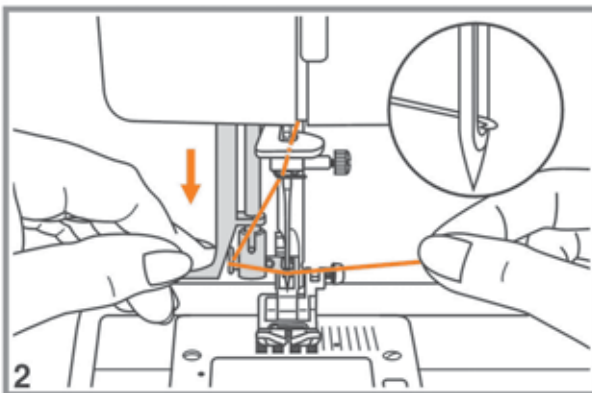
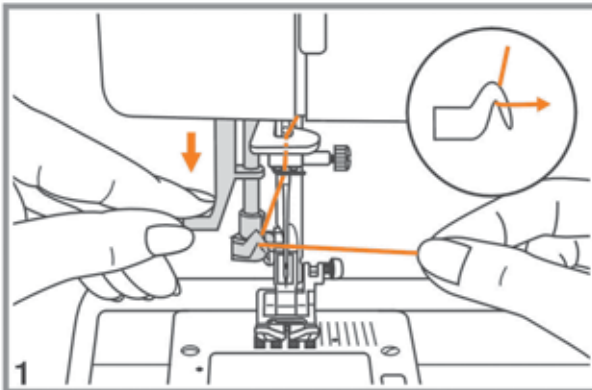

⚠ Attention: Turn power switch to the off position ("O").

Raise the needle to its highest position and lower the presser foot.

1. Lower the needle threader lever slowly and draw the thread through the thread guide as illustrated and then to the right.
2. The needle threader automatically turns to the threading position and the tiny hook passes through the needle eye.
3. Take the thread in front of the needle into the hook from the bottom as illustrated.
4. Hold the thread loosely and release the lever slowly. The hook will turn and pull the thread through the needle eye forming a loop.
Pull the rest of the thread through the needle eye.

TOP THREAD TENSION



- Basic top thread tension setting: "4"
- To increase the tension, turn the dial to the next number up. To reduce the tension, turn the dial to the next number down.
- Proper setting of tension is important to good sewing.
- There is no single tension setting appropriate for all the stitch functions and fabrics.
- 90% of all sewing will be between "3" and "5" ("4" is basic setting).
- For all decorative sewing you will always obtain a nicer stitch and less fabric puckering when top tension is reduced by 1 number so the upper thread appears on the bottom side of your fabric.

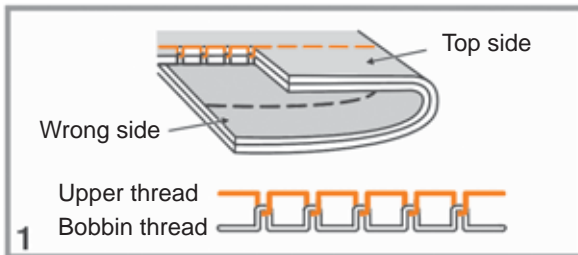

1. Normal thread tension for straight stitch sewing. Top and bobbin thread lock in the fabric.

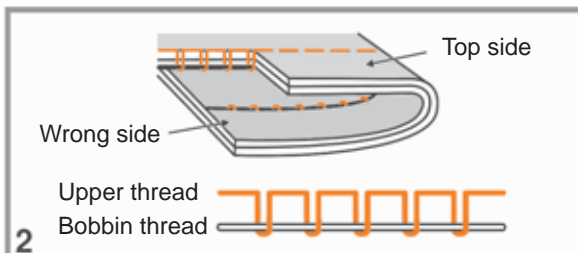

2. Thread tension is too loose for straight stitch sewing. Turn dial to higher number. Top thread loops on wrong side.

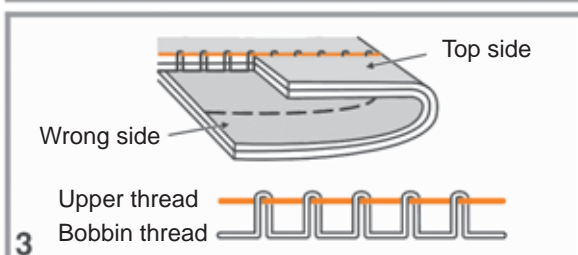

3. Thread tension is too tight for straight stitch sewing. Turn dial to lower number. Bobbin thread loops on top side

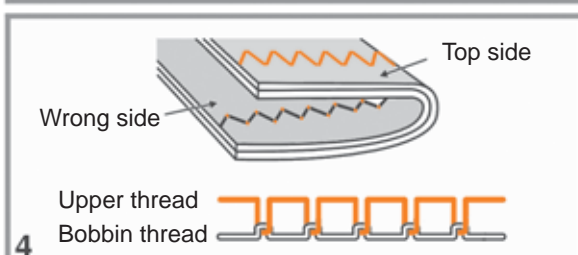

4. Normal thread tension for zigzag and decorative sewing.



BRINGING UP THE BOBBIN THREAD

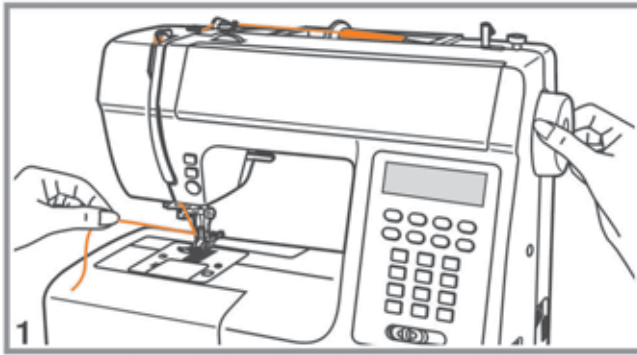

1. Hold the upper thread with the left hand. Turn the handwheel toward you (counterclockwise) lowering, then raising the needle.

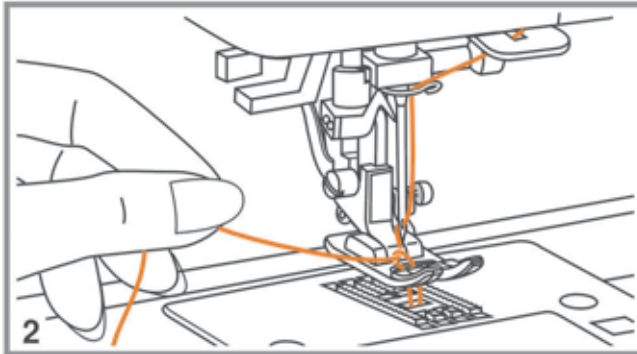

2. Gently pull on the upper thread to bring the bobbin thread up through the needle plate hole. The bobbin thread will come up in a loop.

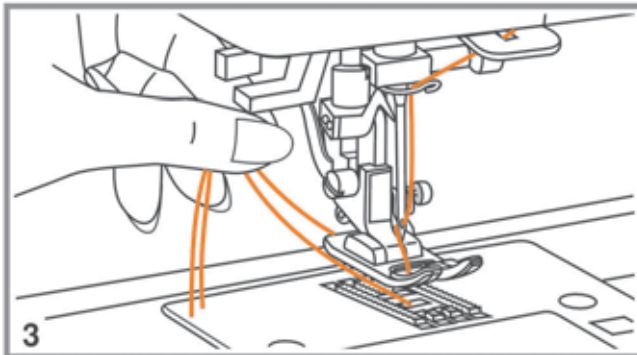

3. Pull both threads to the back under the presser foot.

CUTTING THE THREAD

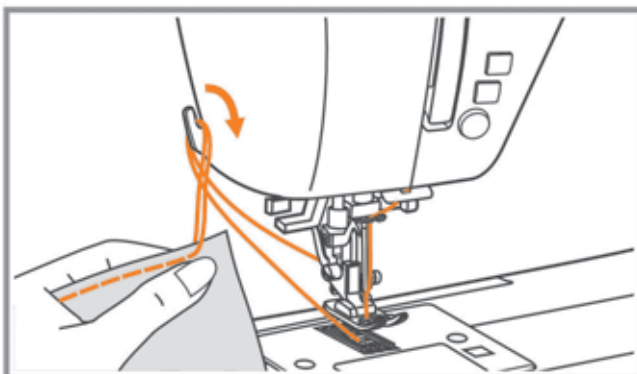

Raise the presser foot. Remove the fabric, draw the threads to the left side of the face cover and cut using the thread cutter.

The threads are cut at the proper length to start the next seam.

PRESSER FOOT LIFT

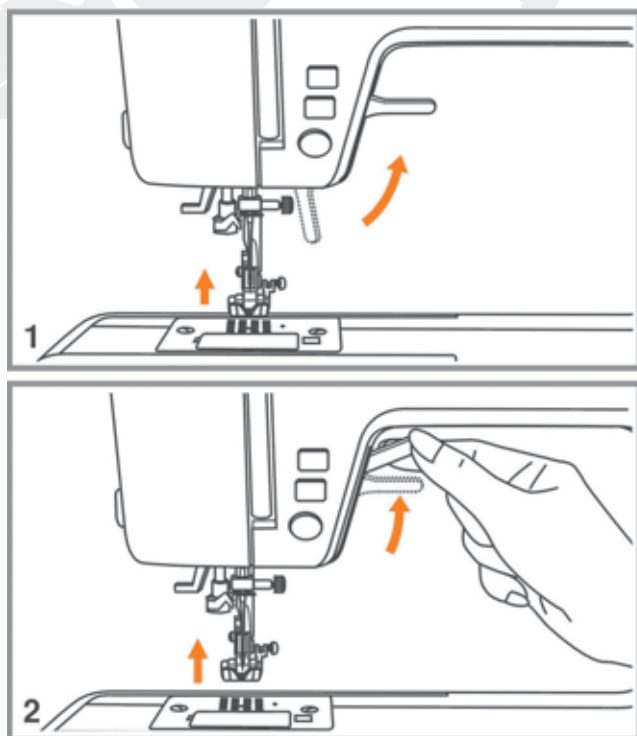

1. The presser foot lift raises and lowers your presser foot.
2. When sewing several layers or thick fabrics, the presser foot can be raised higher for easy positioning of the fabric under the foot.

RAISE OR LOWER THE FEED DOGS

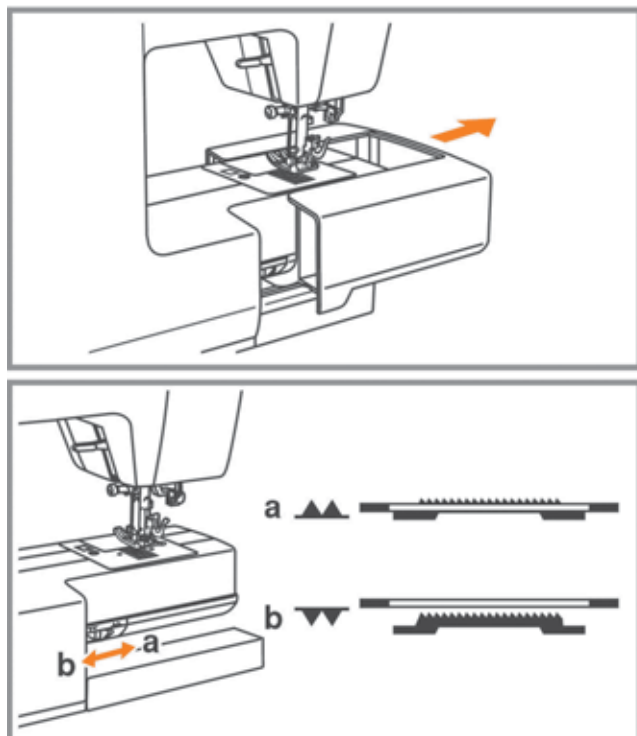

With the accessory box off the machine, the feed dog adjustment lever can be seen on the base in back of the sewing machine.

Sliding the lever to the “▼▼” (b) will lower the feed dog, for example during button sewing. If you wish to continue sewing normally, slide the lever to the “▲▲” (a) in order to raise the feed dogs.

The feed dog will not come up until you turn the handwheel or start sewing, even if the lever is slid to the right. Make a complete turn to raise the feed dogs.

OPERATION BUTTONS

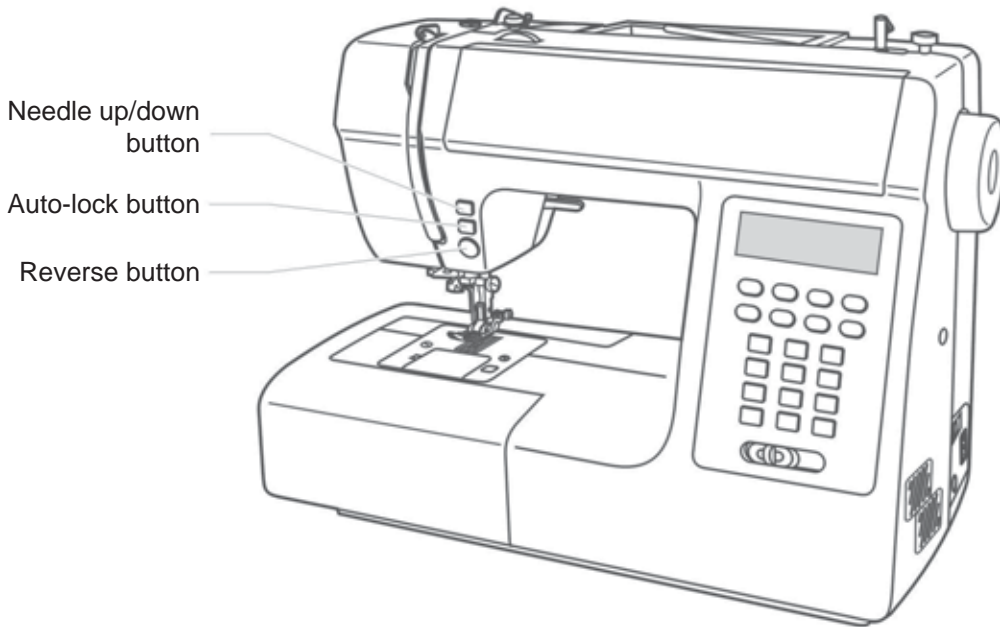

Reverse button

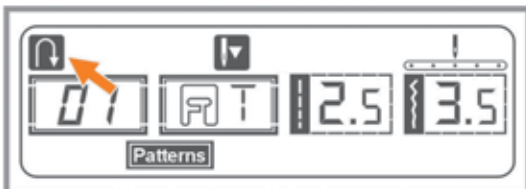

When the patterns 01-16, 30-60 (C10), 01-16, 30-79 (C20) are selected, the machine will sew reverse or a reinforcement stitch at a low speed if the reverse button is pressed. The machine will sew forward after the button is released.

An arrow “” on the LCD display indicates reverse sewing.

Auto-lock button



When the patterns 01-05 are selected, the machine will immediately sew 3 locking stitches when the Auto-lock button is pressed, then automatically stop. The LCD will display the figure “” until the machine is stopped.

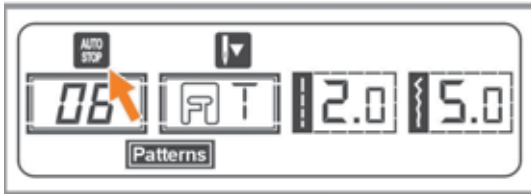

When the patterns 06-16, 30-60 (C10), 06-16, 30-79 (C20) are selected, press the Auto-lock button, the machine will sew 3 locking stitches at the end of the current pattern and automatically stop. The LCD will display the figure “” until the machine is stopped.

The function will be cancelled if you press the button once again or select another pattern.

Needle up/down button

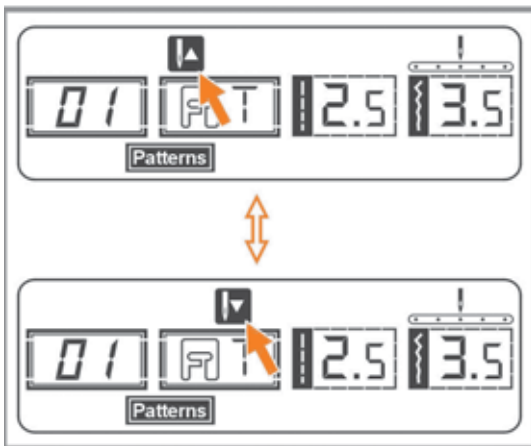



With the Needle up/down button, you decide whether the needle shall stop in the up position or in the fabric when you stop sewing.

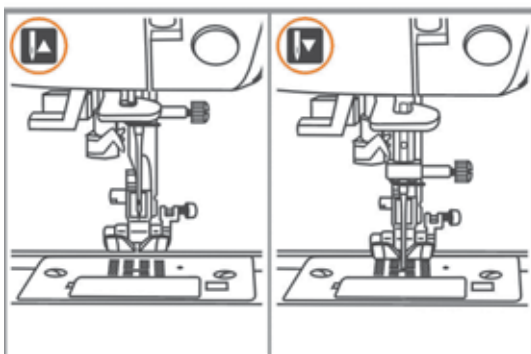

Please Note: During sewing, the needle up/down button has no function. You can only activate the function while the machine is not sewing.



Press the button so that the arrow, on the LCD screen, will point up “” and the needle will stop in the highest position. When you press the button so that the arrow points down “”, the machine will stop with the needle in the lowest position.

FUNCTION BUTTONS



Stitch width button

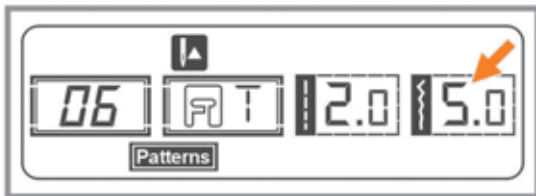

When you select a stitch, the machine will automatically set the recommended stitch width, which will be indicated by numbers on the LCD screen. The stitch width can be changed by pressing the stitch width buttons.



For a narrower stitch, press the “-” button (left). For a wider stitch, press the “+” button (right). The stitch width can be adjusted between “0.0-7.0”. Some stitches have a limited stitch width.

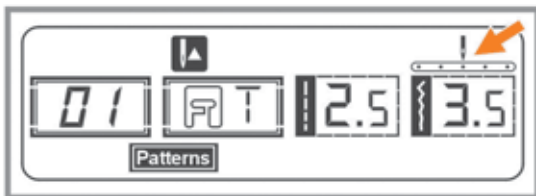

When patterns 01-05 are selected, the needle position is changed by the stitch width adjustment buttons. Pressing the “-” button (left), will move the needle to the left and pressing the “+” button (right), will move the needle to the right. The numbers will be changed from left position “0.0” to extreme right position “7.0”. The pre-set center needle position will be indicated as “3.5”.

Stitch length button

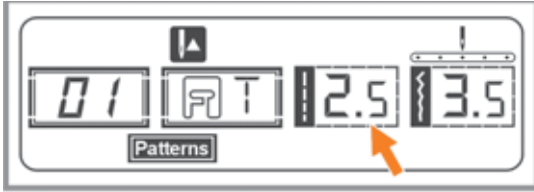

When you select a stitch the machine will automatically set the recommended stitch length which will be indicated by numbers on the LCD screen. The stitch length can be adjusted by pressing the stitch length adjustment buttons.



To shorten the stitch length, press the “-“ button (left). For a longer stitch length, press the “+“ button (right). The stitch length can be adjusted between “0.0-4.5”. Some stitches have a limited length.

MODE selection button

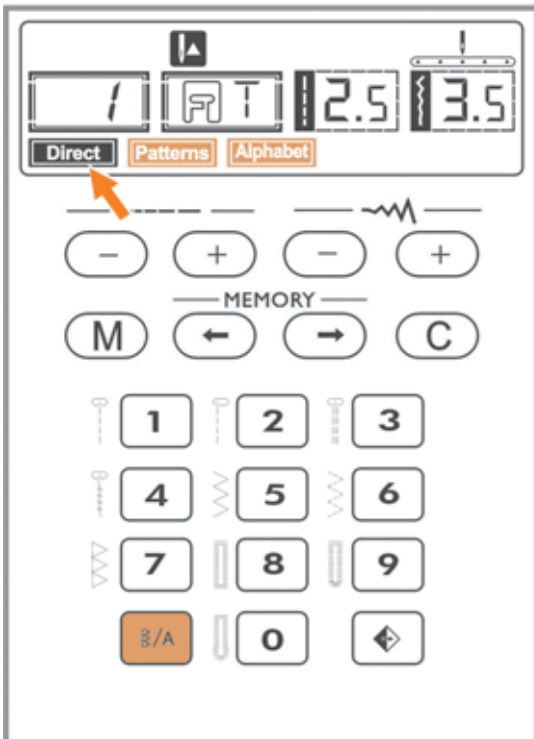

When you turn the machine “ON” the LCD screen display will be set at direct mode “Direct”.

Press the “B/A” button to switch to “Patterns” mode, press the button again and “Alphabet” will be displayed. After a third press the machine will go back to “Direct”.

Direct Direct mode stitch selection.

Patterns Utility and decorative pattern mode: Select stitches by using the number buttons.

Model C20 only:

Alphabet Block letter mode: Select letters by using the number buttons.

Pattern mirroring button

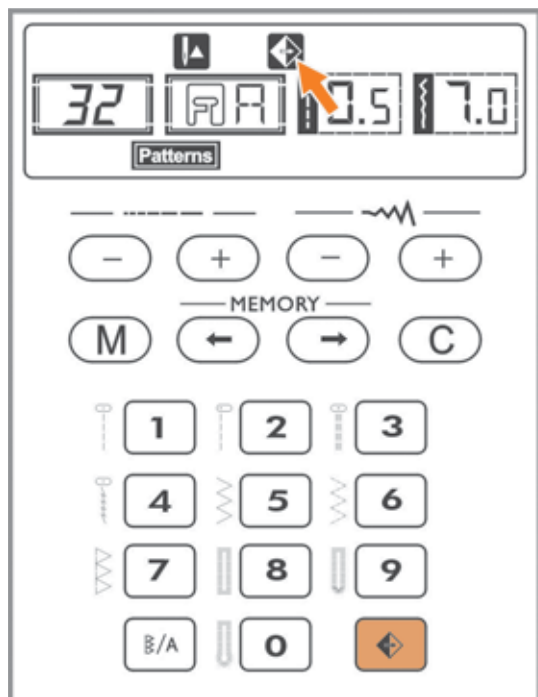

The patterns 01-16, 30-60 (model C10), 01-16, 30-79 (model C20) can be mirrored by pressing the “” button.

The LCD will display the mirroring function and the machine will continue to sew the mirrored pattern until the mirroring function is pressed again to cancel.

When the mirroring function disappears from the LCD screen, the machine will continue to sew the normal stitch.

If you select another pattern, the mirroring function will be cancelled accordingly. Press the mirror button again if you want the new pattern to be mirrored.

SELECTION BUTTONS



Direct pattern selection and number buttons

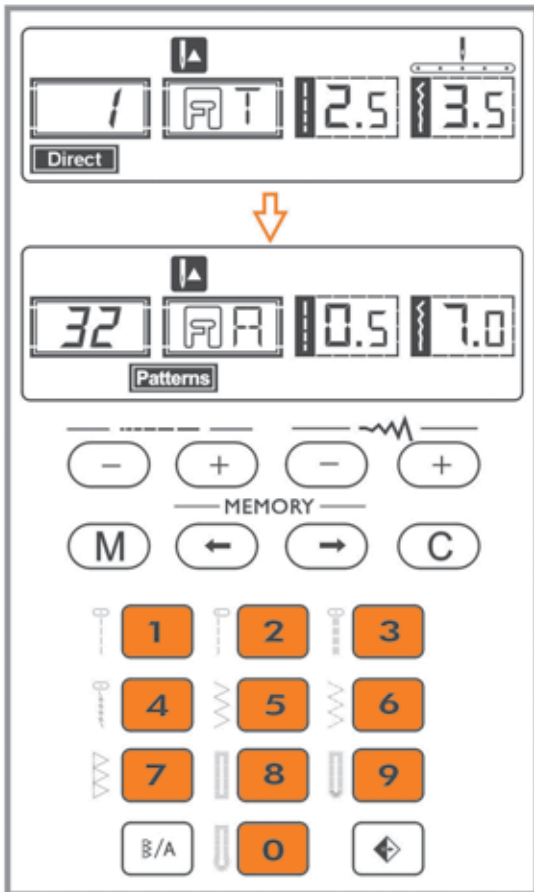

Direct pattern selection buttons

When the mode button is set to Direct mode you can select the utility stitches illustrated next to the buttons simply by pressing the button for the stitch you wish to sew.

Number buttons

When the mode button is set to Patterns or Alphabet mode you select the stitches or letters by number.

MEMORY BUTTONS



Memory button

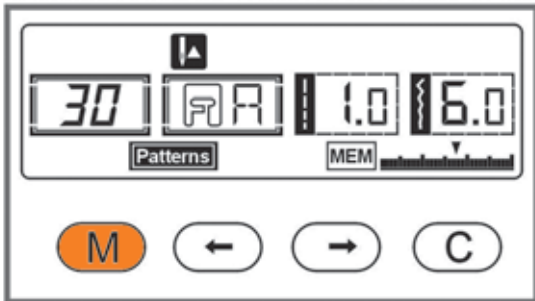

Press the “M” button to enter the memory mode and program combinations of characters or decorative stitches. Press the “M” button again to leave the memory mode and return to Direct mode.

 **Please Note:** The Direct mode patterns and buttonholes cannot be programmed or put into memory.

Clear button

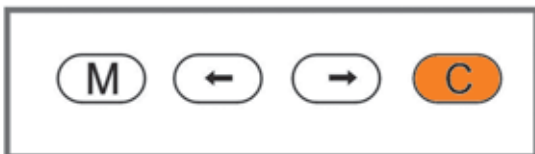

Press this button when the incorrect character is selected. Each press of this button erases one character. Or press this button to remove an added pattern when sewing combinations of characters or decorative stitches.

Arrow button



Press the arrow buttons “←” or “→”, in memory mode, to check the combination programmed in the memory.

USEFUL SKILLS

Sewing corners

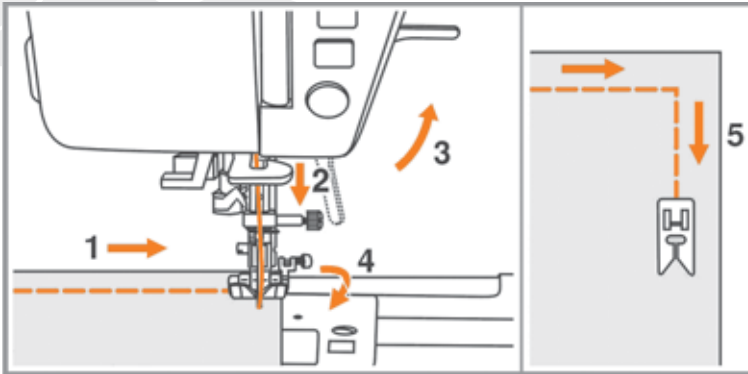

1. Stop the sewing machine when you reach a corner.
2. Lower the needle into the fabric with the hand wheel or by pressing the needle up/down button once.
3. Raise the presser foot.
4. Use the needle as a pivot and turn the fabric.
5. Lower the presser foot and resume sewing.

Reverse

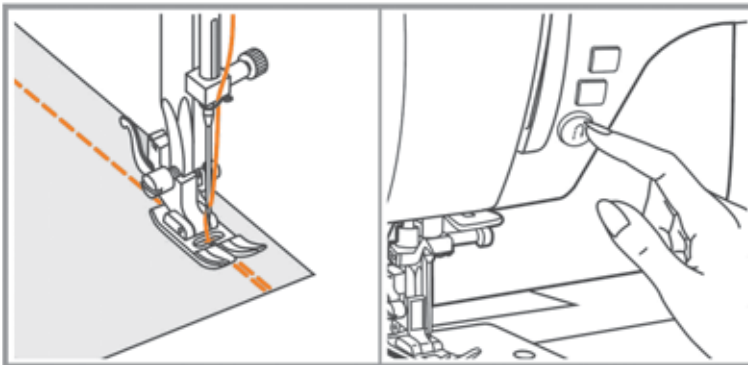

Reverse stitching is used to secure the threads at the beginning and at the end of a seam.

Press the reverse button and sew 4-5 stitches.

The machine will sew forward when the button is released.

Free arm

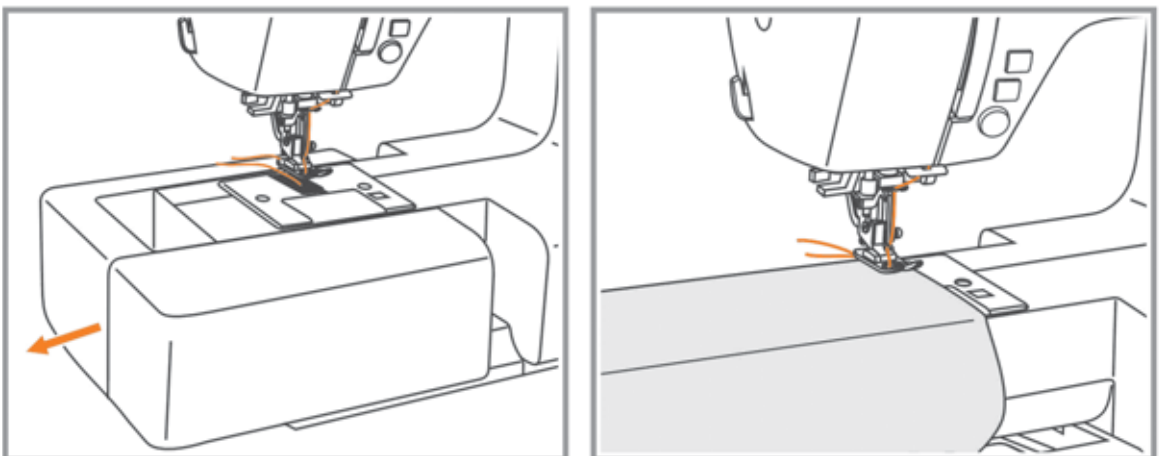

Free arm sewing is convenient for sewing tubular areas such as pant hems and cuffs.

Sewing on heavy fabric

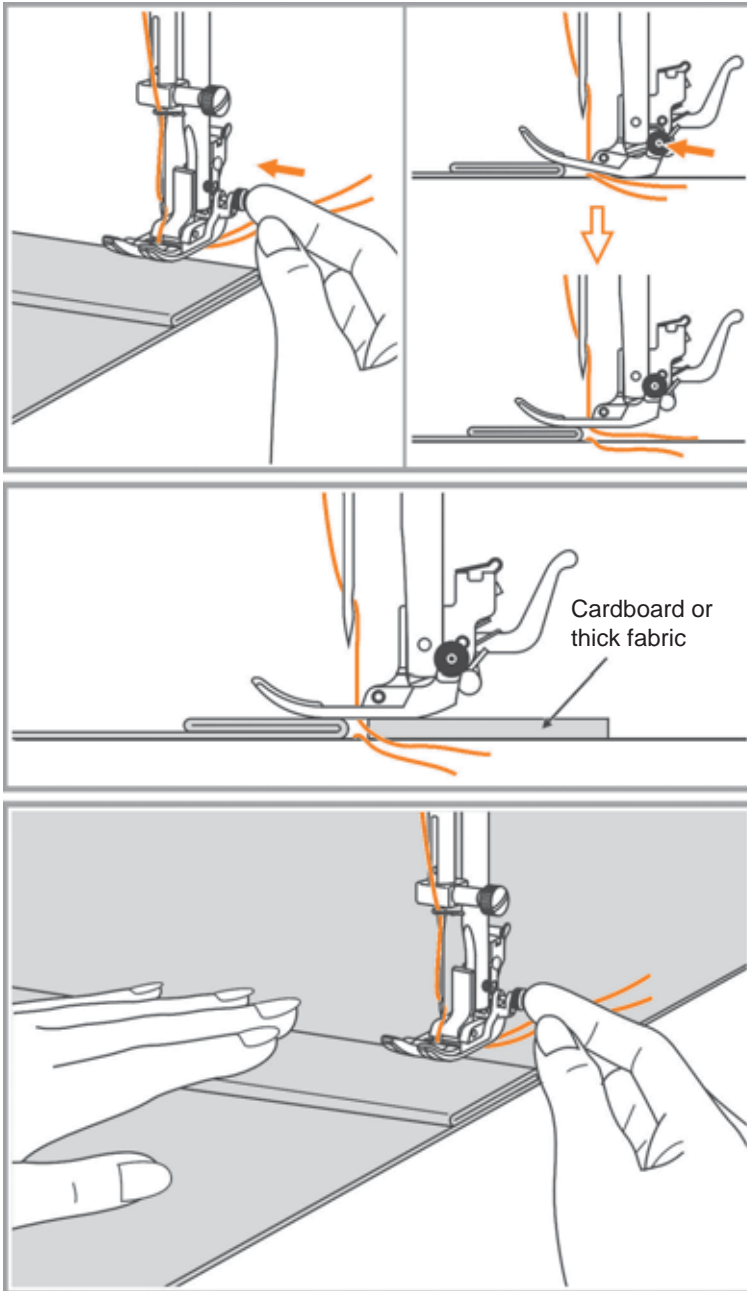

The black button on the right side of the presser foot will lock the presser foot in a horizontal position if you push it in before lowering the presser foot. This ensures even feeding at the beginning of a seam and helps when sewing multiple layers of fabric such as sewing over seams when hemming jeans.

When you reach the point of an increased thickness, lower the needle and raise the presser foot. Press the toe of the foot and push in the black button, then lower the foot and continue sewing.

The black button releases automatically after sewing a few stitches.

You also can place another piece of fabric with the same thickness at the back of the seam. Or support the presser foot while feeding by hand and sewing toward the folded side.

STRAIGHT STITCHES AND NEEDLE POSITION

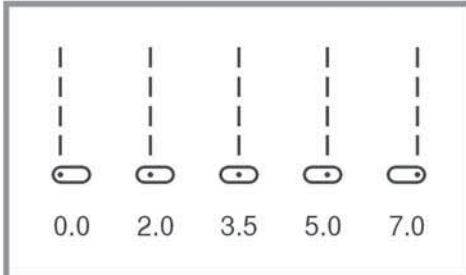
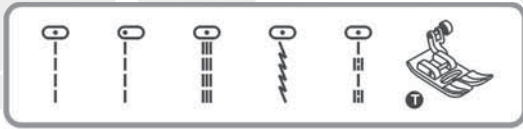

Changing the needle position

These settings apply only to patterns 01-05. The pre-set position is “3.5”, center position. When you press the “-” stitch width adjustment button, the needle position will move to the left. When you press the “+” stitch width adjustment button, the needle position will move to the right. On the LCD screen, the point illustration and the number indicate the needle position.



Changing the stitch length

To shorten the stitch length, press the “-” stitch length adjustment button. For a longer stitch length, press the “+” stitch length adjustment button.

Generally speaking, the thicker the fabric, thread and needle, the longer the stitch should be.

ZIGZAG STITCHES

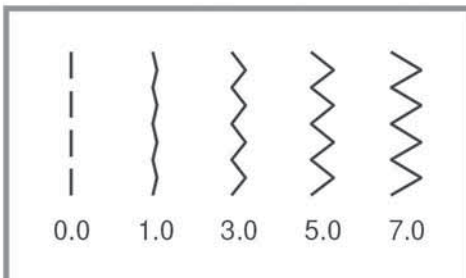
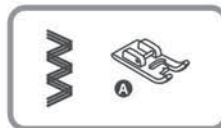

Adjusting the stitch width

The maximum zigzag stitch width for zigzag stitching is “7.0”; however, the width can be reduced on any patterns. The width increases as you press the “+” stitch width adjustment button from “0.0-7.0”.

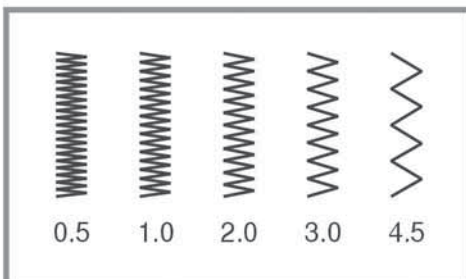

Adjusting the stitch length

The density of zigzag stitches increase as the setting of stitch length approaches “0.2”.

Most zigzag stitches are sewn at “1.0-2.5”.

Dense zigzag stitches (close together) are referred to as a satin stitch.

STRETCH STITCHES

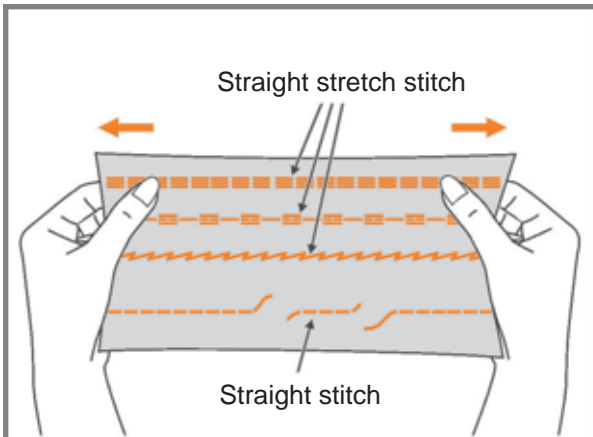

Stretch stitches are strong and flexible and will give with the fabric without breaking. Suitable for easy to ravel and knit fabrics, as well as joining durable fabric such as denims.

These stitches can also be used as decorative top stitches.

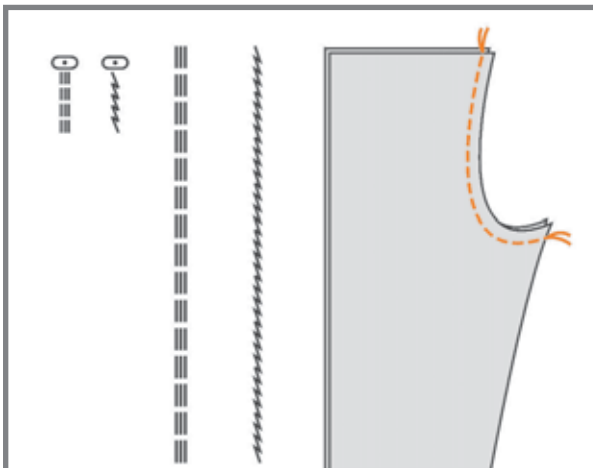

Straight stretch stitch is used to add triple reinforcement to stretch and stressed seams.

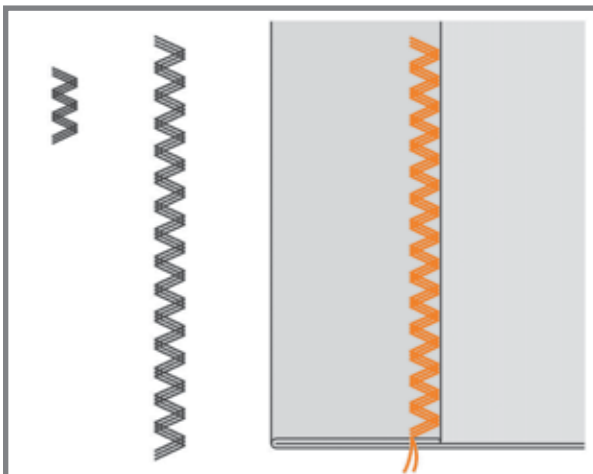



Triple zigzag stretch stitch is suitable for firm fabrics like denim, poplin, duck, etc.

OVERCASTING STITCHES

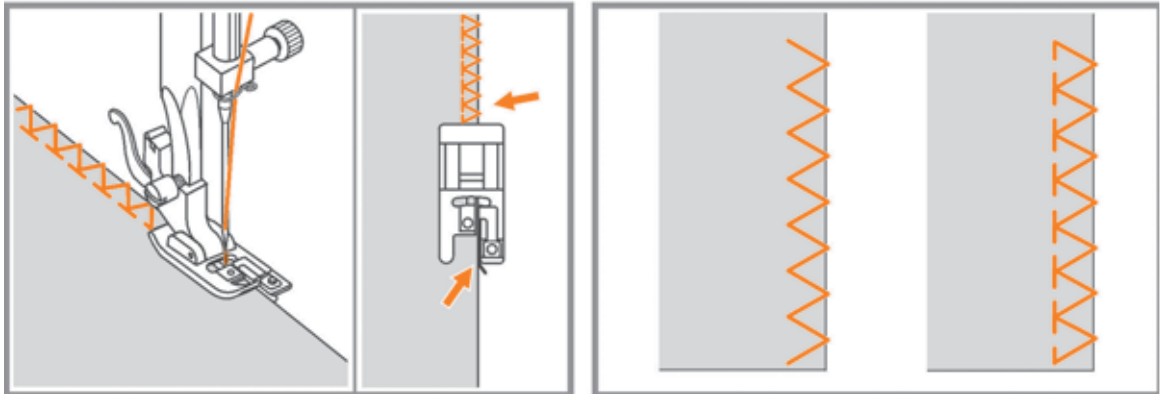
Using the overcasting foot



1. Change the presser foot to the overcasting foot (E).
2. Sew the fabric with the fabric edge against the guide of the overcasting foot.

⚠ Attention: The overcasting foot should be used to sew with patterns  and  only. Do not set the stitch width narrower than "5.0". It is possible for the needle to hit the presser foot and break when sewing other patterns or using another width.

Using the standard foot

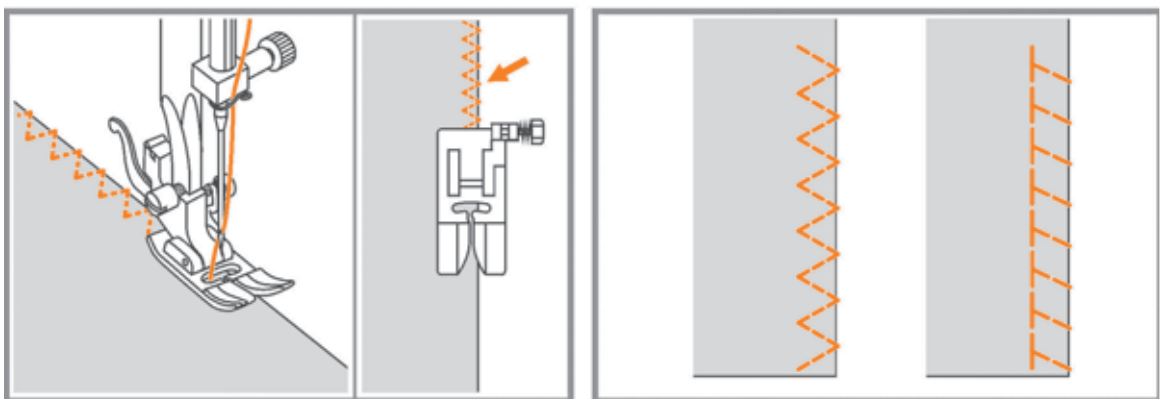

1. Change the presser foot to the standard foot (T) .
2. Overcast along the edge of the fabric so that the needle drops over the edge of the fabric on the right side.

BLINDHEM

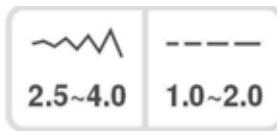

 : Blindhem for woven fabrics

 : Blindhem for stretch fabrics

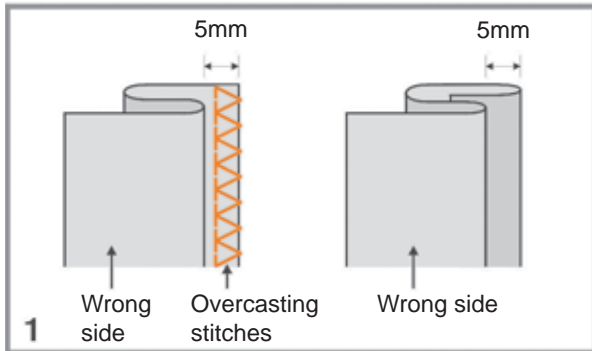

 **Please Note:** It takes practice to sew blindhems. Always make a sewing test first.

Snap on foot F.

1. Fold the fabric as illustrated with the wrong side up.

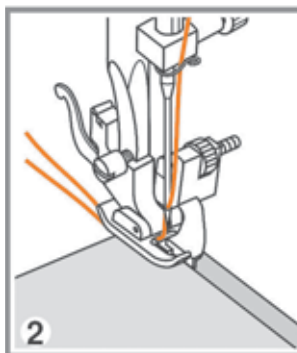

2. Place the fabric under the foot. Turn the handwheel forwards by hand until the needle swings fully to the left. It should just pierce the fold of the fabric. If it does not, adjust the stitch width accordingly.

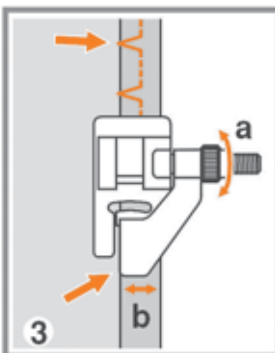

3. Adjust the guide on the foot (b) by turning the knob (a) so that the guide just rests against the fold.

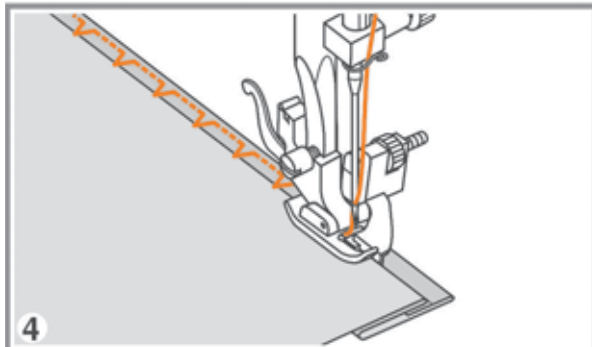

4. Sew slowly, guiding the fabric carefully along the edge of the guide.

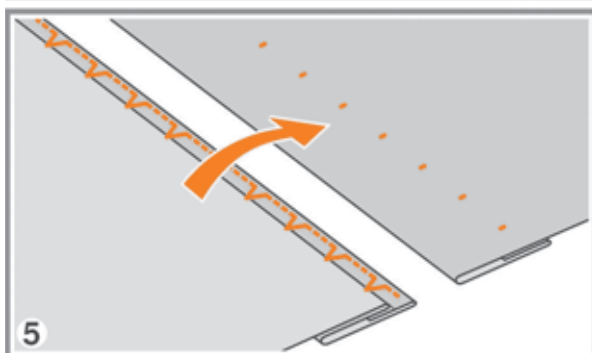

5. Turn fabric to right side.

BUTTON SEWING



 **Please note:** The button sewing foot only comes with model C20.

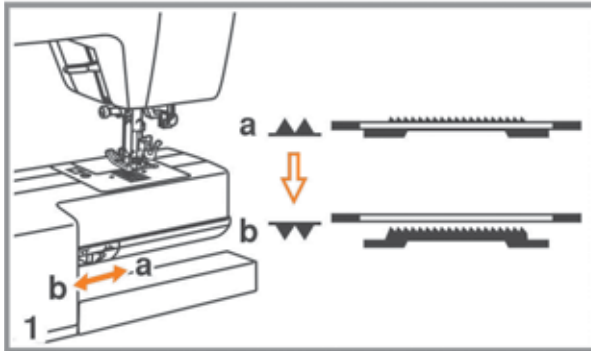

Change the presser foot to the button sewing foot.

1. Move the feed dog adjustment lever to ▼ to lower the feed dogs.

2. Position the fabric under the foot. Place the button in the desired position, lower the foot on to the button.

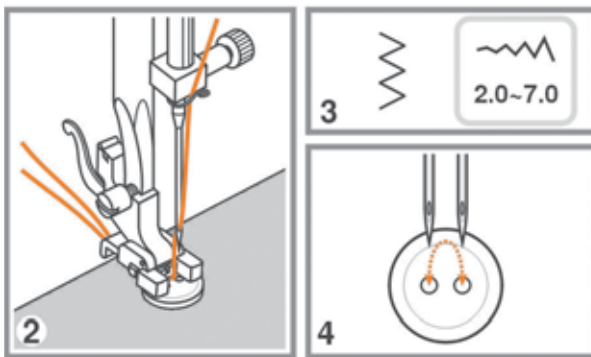

3. Select zig zag pattern. Adjust the stitch width to “2.0-7.0” according to the distance between the two holes of the button.

4. Turn the handwheel to check that the needle goes cleanly into the left and right holes of the button.

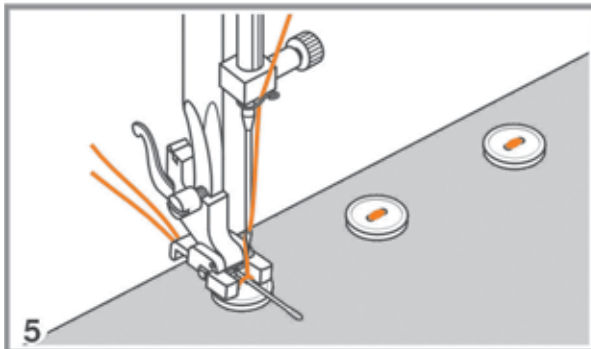

5. Before sewing, press the Auto-lock button to automatically sew reinforcement stitches at the beginning and at the end of the stitch.

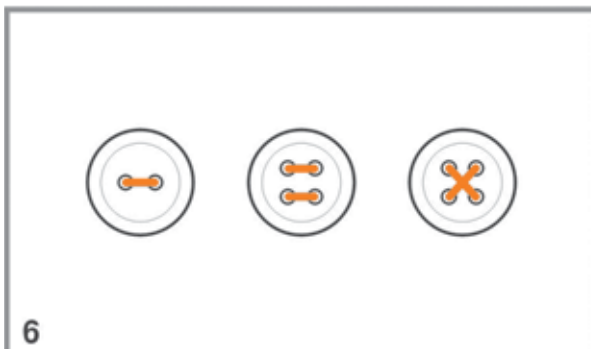

6 For buttons with 4 holes, sew the two front holes first, pull fabric forward and then sew the two holes back.

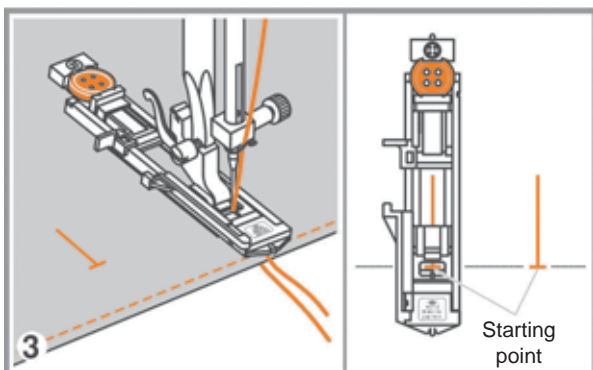

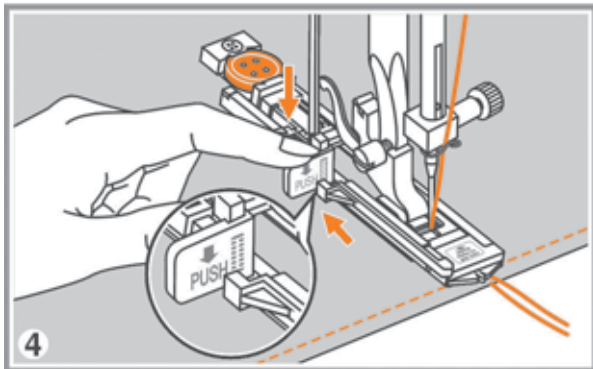

3. Select the buttonhole stitch. Adjust the stitch width and the stitch length to the desired width and density.



4. Position the fabric under the presser foot so that the buttonhole mark is aligned with the center of the buttonhole foot. Pull down the buttonhole lever, then push it to the back.



-  **Please Note:** When you select any buttonhole pattern the LCD screen will display the figure “”, to remind you to lower the buttonhole lever.

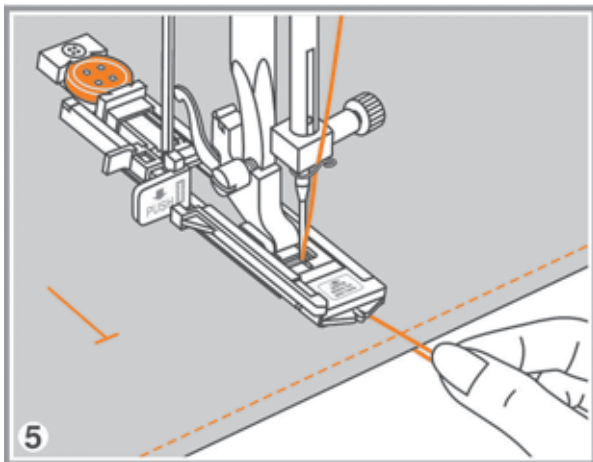

5. Lightly hold the end of the upper thread and start sewing.

-  **Please Note:** Before stopping, the machine will automatically sew a reinforcement stitch after the buttonhole is sewn.

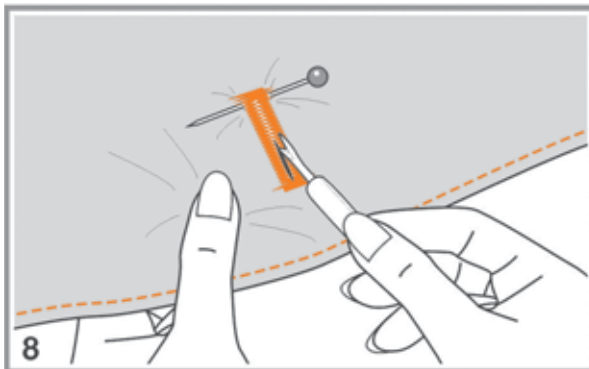
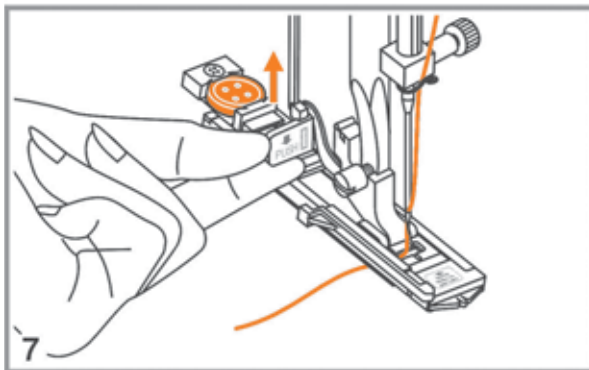
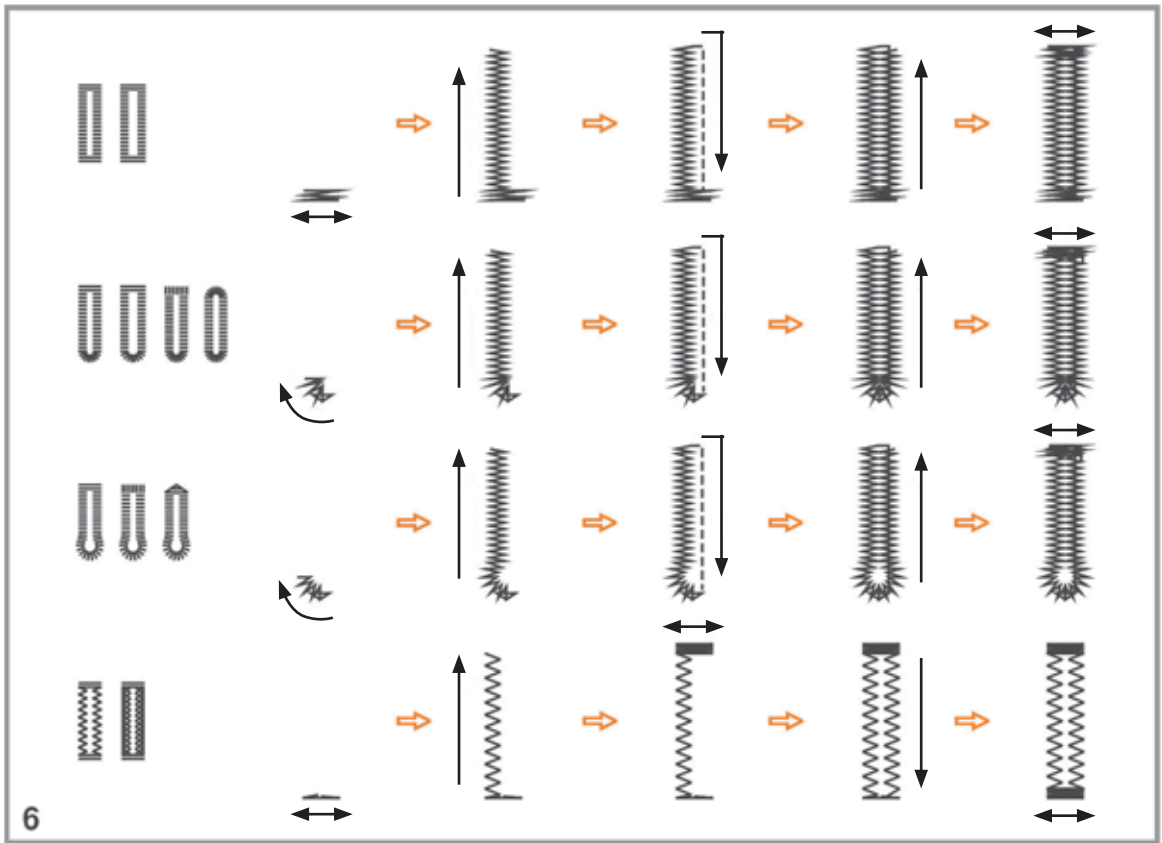

6. Buttonholes are sewn from the front of the presser foot to the back, as shown.
7. Raise the presser foot and cut the thread. To sew the buttonhole once again, raise the presser foot and it will return to original position. When you have finished sewing buttonholes, push the buttonhole lever up until it stops.
8. Cut the center of the buttonhole being careful not to cut any stitches on either side. Use a pin as a stopper at the bartack so you do not cut too much.

Making a corded buttonhole on stretch fabrics

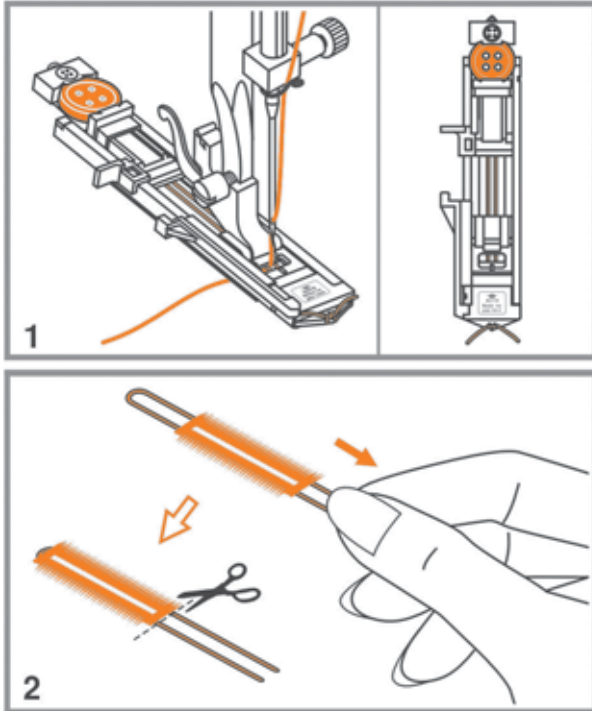

1. Attach the buttonhole foot and hook the gimp thread onto the back of the presser foot. Bring the two gimp thread ends to the front of the foot and insert them into the grooves, then temporarily tie them there. Lower the presser foot and start sewing.

Set the stitch width to match the diameter of the gimp thread.

2. Once sewing is completed, pull the gimp thread gently to remove any slack, then trim off any excess.



Please Note: It is suggested that you use interfacing on the wrong side of the fabric.

EYELET STITCH

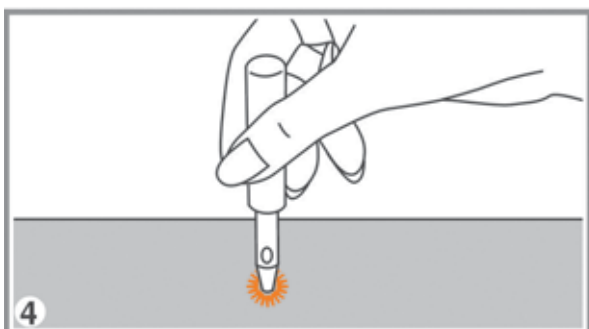
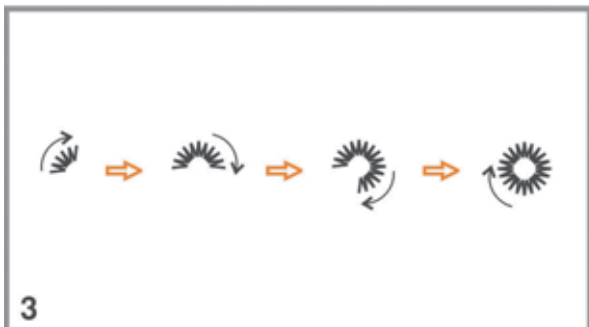
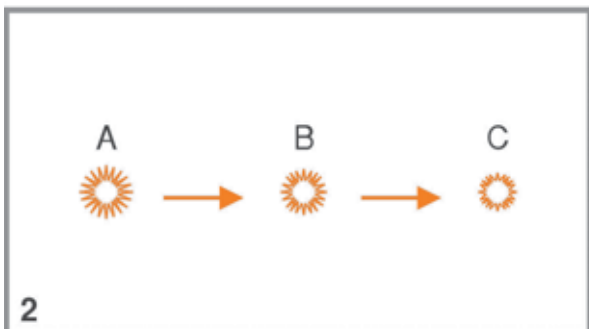
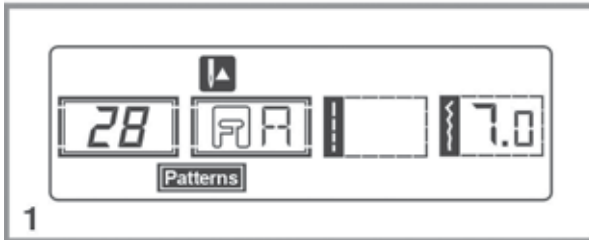
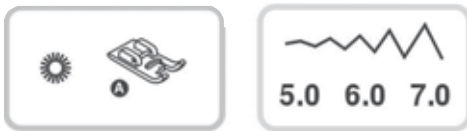

☉ : Select for sewing eyelets on belts , etc

1. Select pattern 28 to get the eyelet stitch. Attach satin stitch foot (A).

2. Press the “-” or “+” stitch width adjustment to select the eyelet size.

Size of eyelet:

- A. Large: 7.0mm (1/4 inch).
- B. Medium: 6.0mm (15/64 inch).
- C. Small: 5.0mm (3/16 inch).

3. Lower the needle into the fabric at the beginning of the stitching, and then lower the presser foot lever.

Once sewing is completed, the machine automatically sews reinforcement stitches, then stops.

4. Make a hole at the center using an eyelet punch.

* Eyelet punch is not included with the machine.

 **Please Note:** If thin thread is used, the stitching may not be dense enough. If this occurs, sew the eyelet twice one on top of the other.

DARNING STITCH

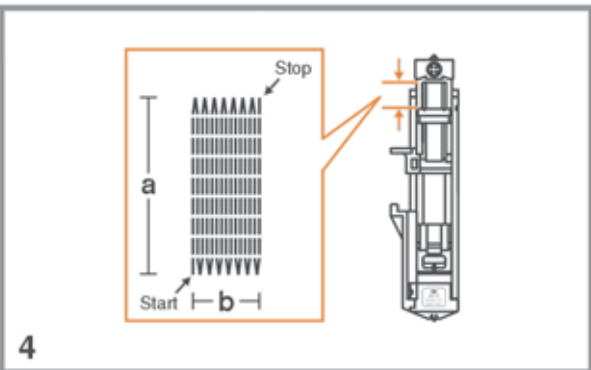
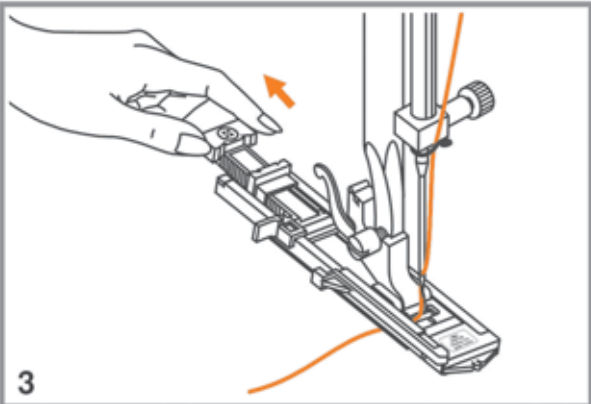
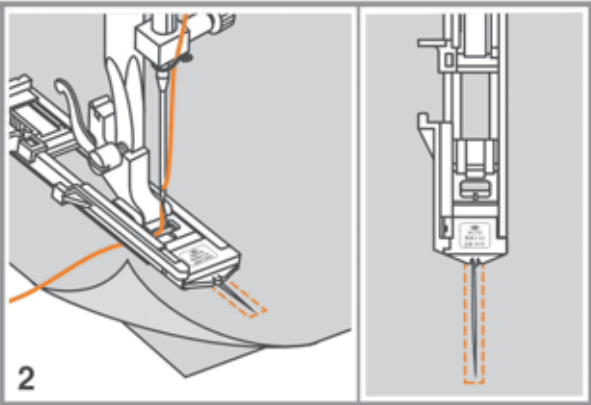
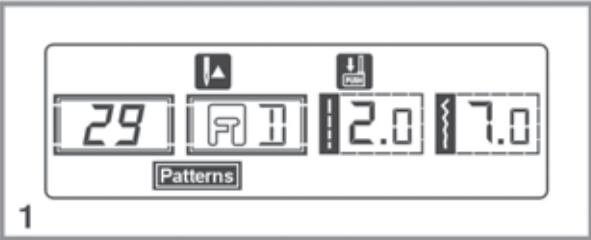
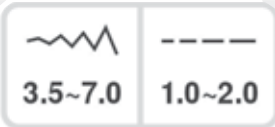
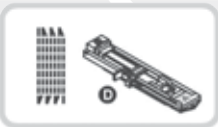

1. Baste the upper fabric and the under fabric together.
 Select pattern 29 to get the darning stitch.
 Change the presser foot to the buttonhole foot.

2. Lower the presser foot over the center of the tear.

3. Pull the button holder to rear. Set the button guide plate on buttonhole foot to the desired length of the darning stitch.

4. The size of one darning stitch is variable. However, the maximum stitch length is 2.6cm (1 inch) and the maximum stitch width is 7mm (9/32 inch).

- a. The length of sewing.
- b. The width of sewing.

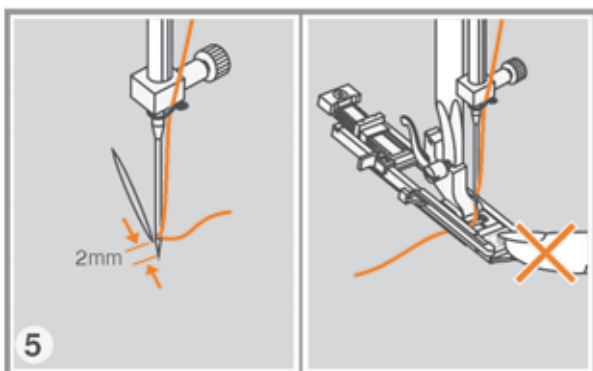

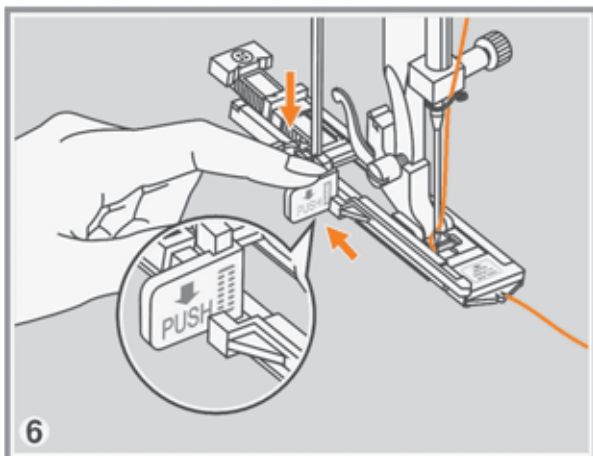

- Position the fabric so that the needle is 2mm (1/16 inch) in front of the area to be darned, and then lower the presser foot level.

 **Please Note:** When lowering the presser foot, do not push in the front of the presser foot, otherwise the darning will not be sewn with the correct size.



- Pass the upper thread down through the hole in the presser foot. Pull down the buttonhole lever then push it back. The buttonhole lever is positioned behind the bracket on the buttonhole foot. Gently hold the end of the upper thread in your left hand, and then start sewing.

 **Please Note:** When you select any buttonhole pattern or darning pattern, the LCD screen will display the figure “”, to remind you to pull down the buttonhole lever.

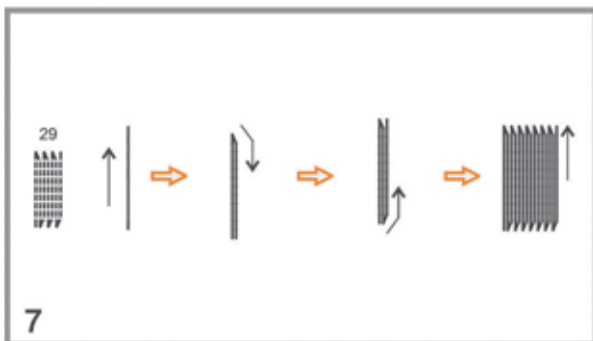

- Darning stitches are sewn from the front of the presser foot to the back, as shown.

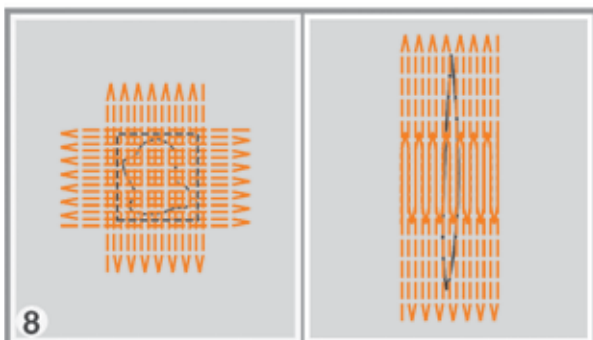

- If the area to be darned is too big to sew with one darning stitch, you can sew several times (or cross sew) to get better sewing result.

ZIPPER INSERTION

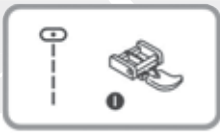

Attention: Zipper foot should be used for sewing with center needle position straight stitch only. It is possible that needle could hit the presser foot and break when sewing other patterns.

Inserting a centered zipper

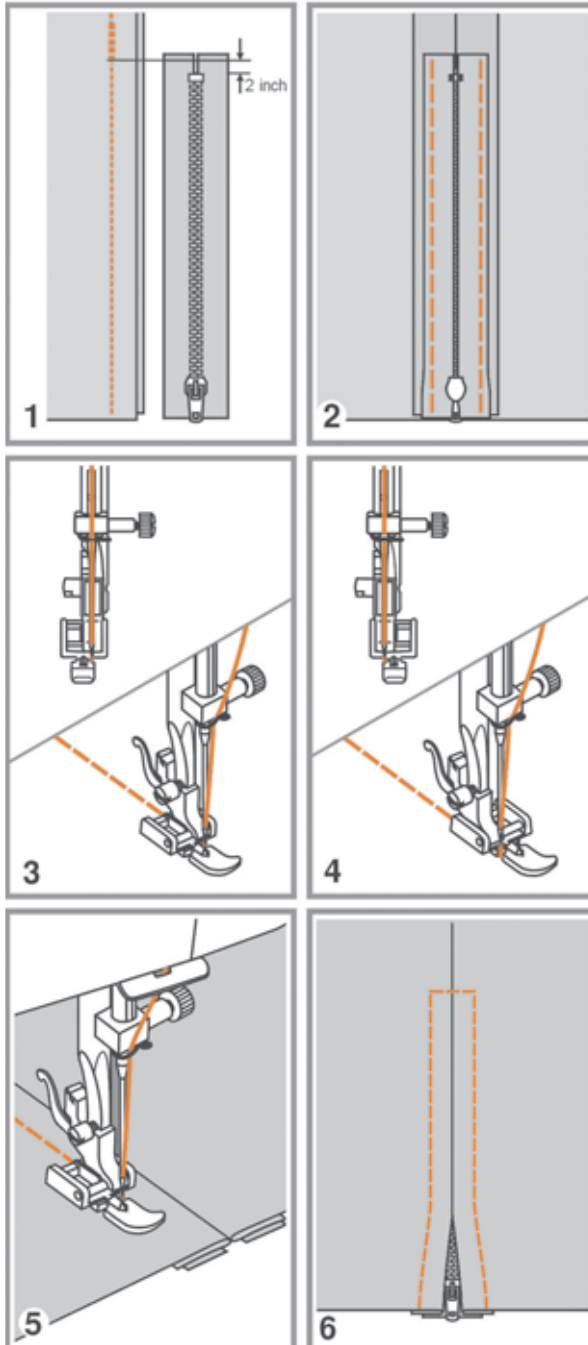

1. Baste the zipper opening on the garment.
2. Press open the seam allowance. Place the zipper face down on the seam allowance with the teeth against the seam line. Baste the zipper tape.
3. Attach the zipper foot. Attach the right side of the presser foot pin to the holder when sewing the left side of the zipper.
4. Attach the left side of the presser foot pin to the presser foot holder when sewing the right side of the zipper.
5. Stitch left side of the zipper from bottom to top.
6. Stitch across the lower end and right side of zipper. Remove the basting and press.

QUILTING

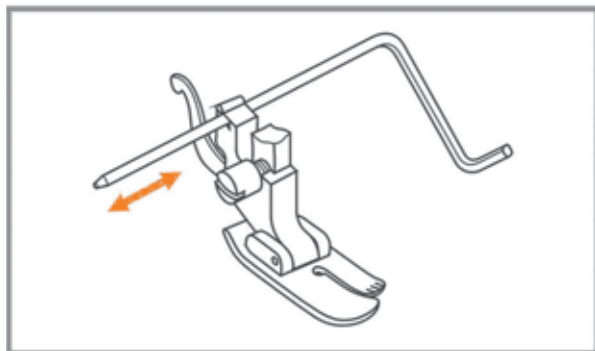
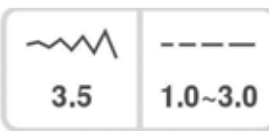

Insert the quilting guide in the presser foot holder as illustrated and set the space as you desire.

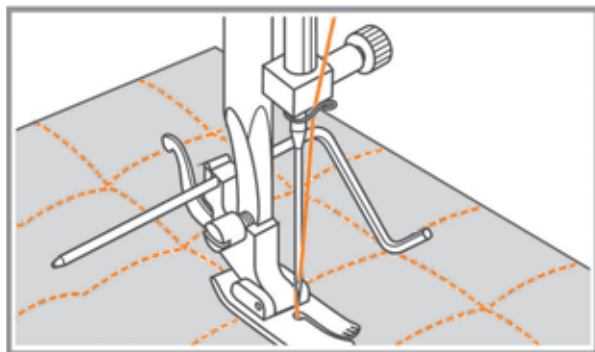

Sew the first row and move the fabric to sew parallel rows of channel quilting with the guide riding along the previous row of stitching.

FREE-MOTION, DARNING, EMBROIDERY AND MONOGRAMMING

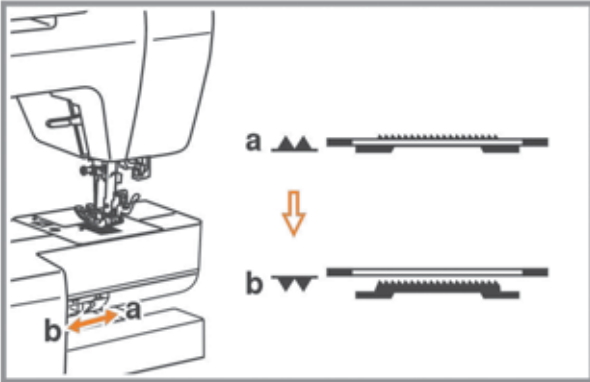

Move the drop feed control to “▼” to lower the feed dogs.

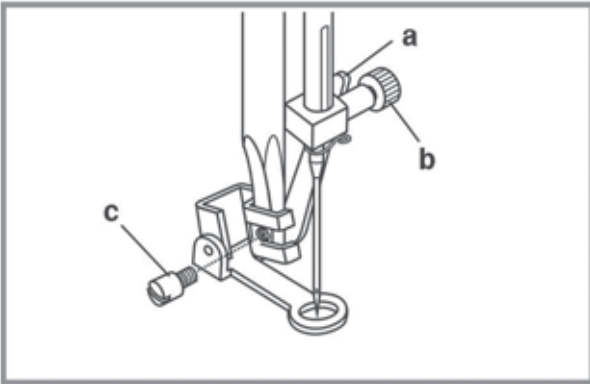

Remove the presser foot holder, and attach the free-motion/darning foot to the presser foot holder bar. The lever (a) should be behind the needle clamp screw (b). Press the free-motion/darning foot on firmly from behind with your index finger and tighten the screw (c).

Darning



Please Note: Free-motion darning is accomplished without the sewing machine internal feed system. Movement of the fabric is controlled by the operator. It is necessary to coordinate sewing speed and movement of fabric.

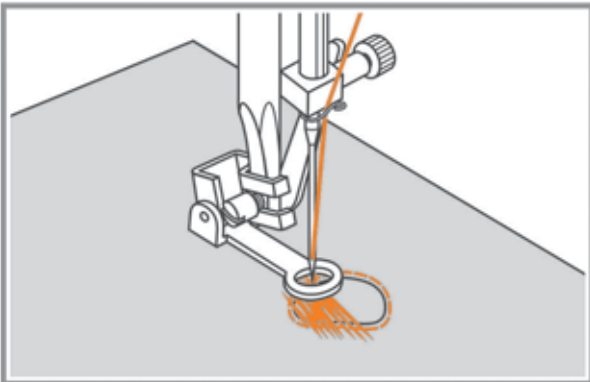

Begin by sewing around the edges of the hole (to secure the threads). Working from left to right, sew over the hole in a constant and continuous movement. Turn the work by 1/4 and sew over the first stitching moving the work slower over the hole to separate the threads and not form big gaps between the threads.

Embroidery

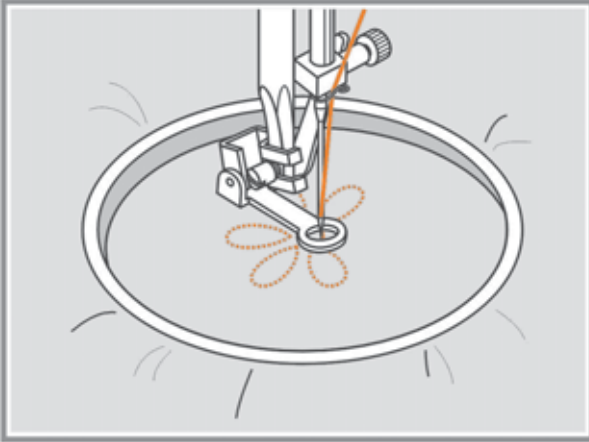

Select zigzag stitch pattern and adjust the stitch width as desired.

Stitch along the outline of the design by moving the embroidery hoop. Make sure to maintain a constant speed.

Fill in the design working from the outline towards the inside. Keep the stitches close together.

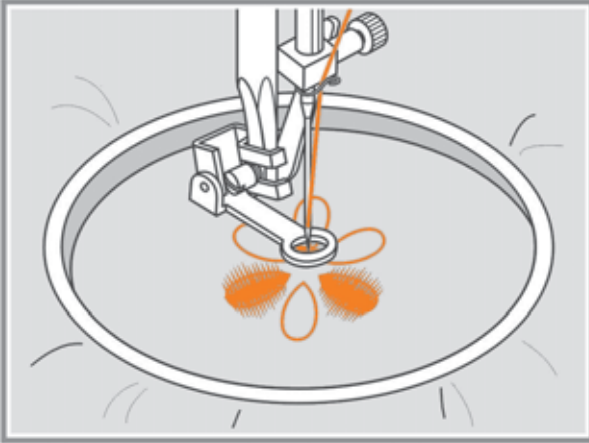

You will get longer stitches by moving the hoop faster and shorter stitches by moving the hoop more slowly.

Secure with a reinforcement stitches at the end by press Auto-lock button.

Monogramming

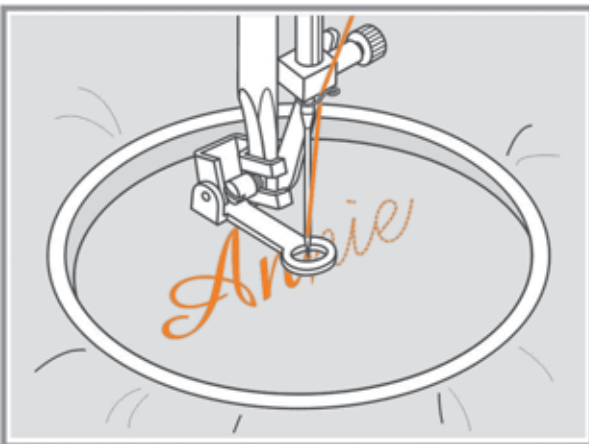

Select the zigzag stitch pattern and adjust the stitch width as desired. Sew at a constant speed, moving the hoop slowly along the lettering.

When the letter is finished. Secure with a reinforcement stitches at the end by press Auto-lock button.

* Embroidery hoop is not included with the machine.

MIRRORING



Please Note:

- Buttonholes, darning and eyelet stitches cannot be mirrored.
- Mirrored patterns can also be combined with other patterns.



1. Select the pattern.

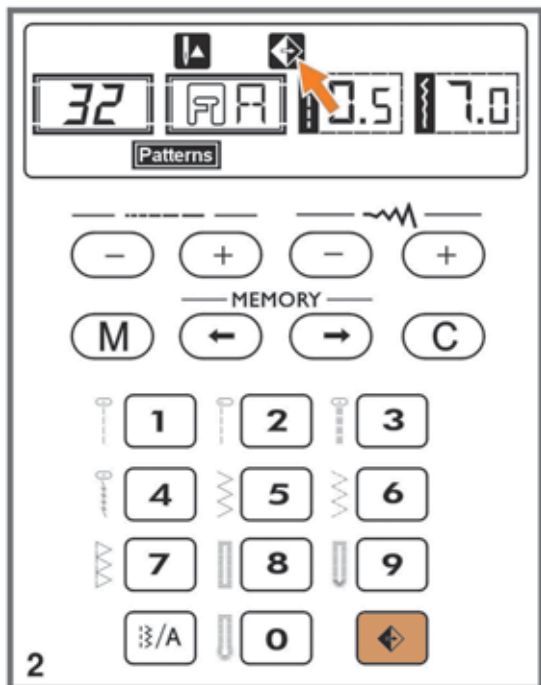

2. Pressing the mirroring button. LCD will display the mirroring function and the machine will sew the mirrored pattern until you press the mirroring button again.

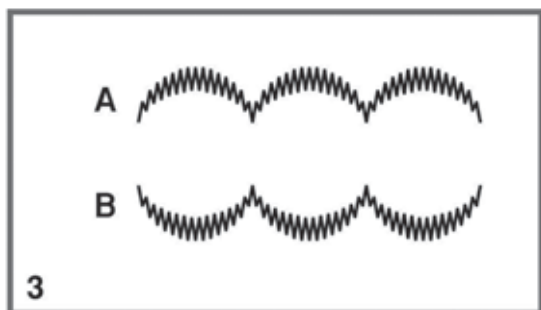

A. Normal pattern sewing.

B. Mirror pattern sewing.

MEMORY - MODEL C10

Combined patterns can be stored for later use. Since stored patterns are not lost after the sewing machine is turned off, they can be recalled at any time.



Please Note:

- The machine has a program memory that can retain 30 units of stitches.
- All the units in the memory can be edited to set its function such as Stitch length, Stitch width, Mirroring and Auto-lock.
- The Direct mode patterns and buttonholes can not be programmed.

Programming patterns



1. When you turn the machine "ON", the LCD screen displays " **Direct** " .

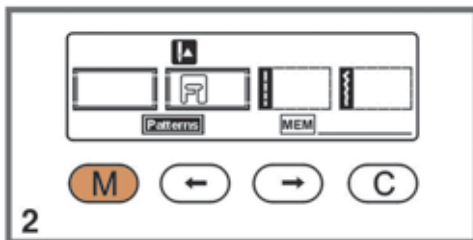

2. Press the " **M** " button to enter the memory mode, to program combinations of character or decorative stitches.

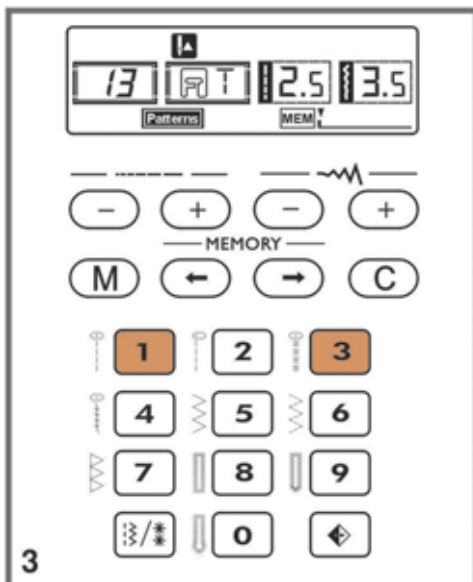

3. Press the " **13** " button to select any desired pattern among " **Patterns** " on the LCD screen. Then press the desired pattern number (E.g.13). (You can change the stitch length, width, or choose the Auto-stop, mirroring function if desired).

Repeat step 3 for more patterns to be stored in the memory.



Please Note: When the maximum of 30 units of patterns has been programmed, the machine will beep to signal the memory is full.

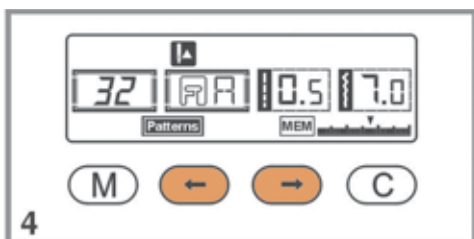

4. Use the arrow “←” or “→” button to switch between the stitches in the combination and check what you have programmed.

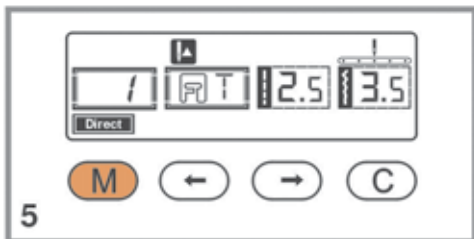

5. Press the “M” button to leave the memory mode and return to the Direct mode.

Attention: The selected pattern will be cleared from the memory module after closing the machine if you do not press the “M” button again when you have completed your selection.

Adding patterns

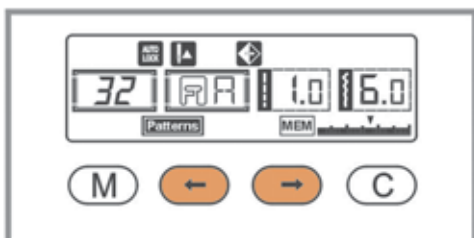

While in the memory mode, press the “←” button or the “→” button until the stitch number you have selected is displayed, then add the new stitch or change the stitch length and width, or add Auto-stop or mirroring, if desired.

Clearing patterns

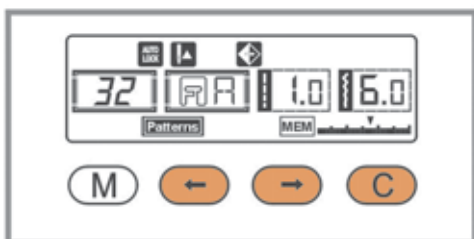

If you wish to delete a certain stitch within in the memory mode, use the “←” button or “→” button until the actual stitch number is displayed.

Press the “C” button to delete the selected pattern and the following patterns in the program will move back.

Recall and sew the memorized pattern

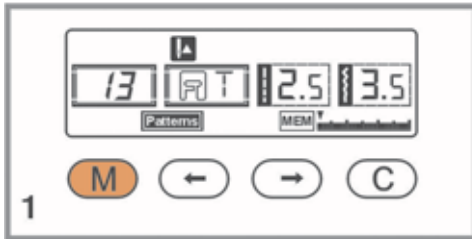

1. Press the “M” button to enter the memory mode. The machine will be positioned at the first programmed stitch.

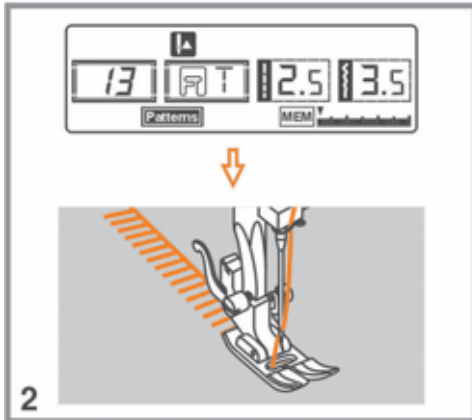

2. Press the foot control. The machine will start to sew from first entered pattern. On the LCD screen, sewing stitch data is indicated.

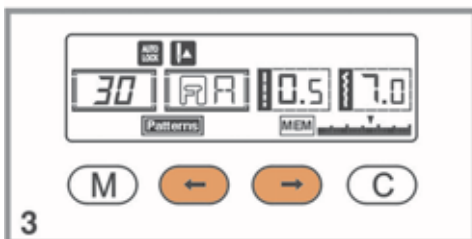

3. If you wish to check what is programmed or if you wish to start sewing a few stitches in the memory mode, use the “←” button or “→” button. You can use the Auto-lock “●” function when the sewing machine is stopped.



Please Note: If you wish to repeat your stitch combination without having the machine stop press the Auto-lock “●” button to cancel the Auto-Stop in the memory mode. The “” will disappear from the LCD screen.

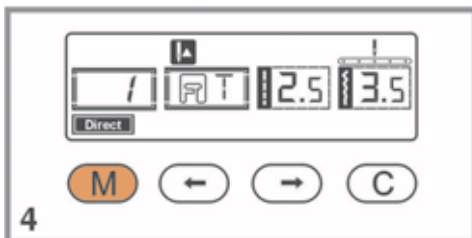

4. Press the “M” button to leave the memory mode and return to the Direct mode.

MEMORY - MODEL C20

Combined patterns can be stored for later use. Since stored patterns are not lost after the sewing machine is turned off, they can be recalled at any time. This is convenient for patterns, such as names, that will be used often.



Please Note:

- The machine has a program memory that can retain 30 units of stitches.
- Multiple patterns selecting from pattern modes “ **Patterns** ”, “ **Alphabet** ” can be combined and sewn together.
- All the units in the memory can be edited to set its function such as Stitch length, Stitch width, Mirroring and Auto-lock.
- The Direct mode patterns and buttonholes can not be memorized.

Programming patterns



1. When you turn the machine “ON”, the LCD screen displays “ **Direct** ” .

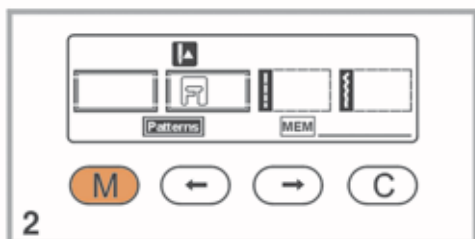

2. Press the “ **M** ” button to enter the memory mode, and store the combinations of character or decorative stitches.

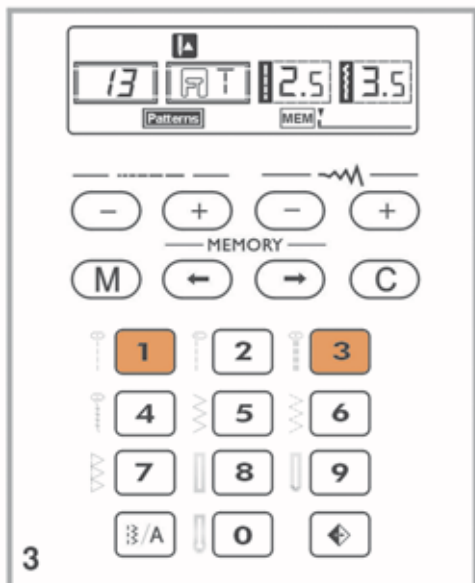

3. Press the “ **B/A** ” button to select any desired pattern group among “ **Patterns** ” or “ **Alphabet** ” on the LCD screen. Then press the desired pattern number (E.g.13). (You can change the stitch length, width, or choose the Auto-stop, mirroring function if desired.)
Repeat step 3 for more patterns to be stored in the memory.



Please Note: When the maximum of 30 units of patterns has been programmed, the machine will beep to signal the memory is full.

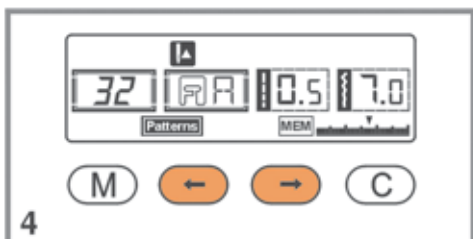

4. Use the arrow “←” or “→” button to check what you have programmed.

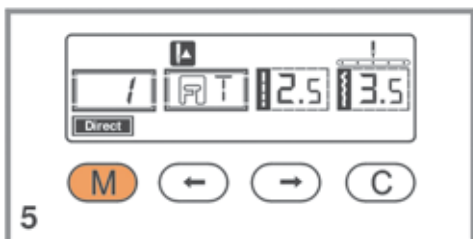

5. Press the “M” button to leave the memory mode and return to the Direct mode.



Attention: The selected pattern will be cleared from the memory module after closing the machine if you do not press the “M” button again when you have completed your selection.

Adding patterns or letters

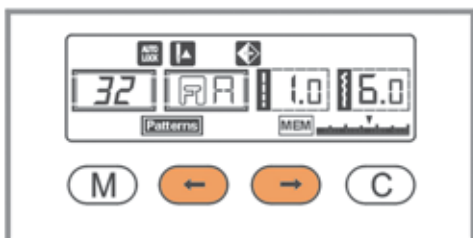

While in the memory mode, press the “←” button or the “→” button until the stitch number you have selected is displayed, then add the new stitch or change the stitch length, width, Auto-stop or mirror, if desire.

Clearing patterns or letters

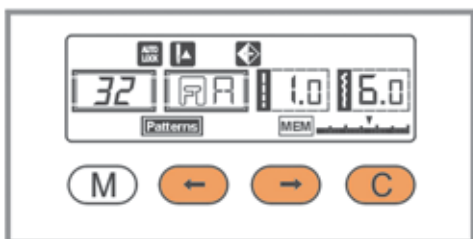

If you wish to delete a certain stitch within in the memory mode, use the “←” button or “→” button until the actual stitch number is displayed.

Press the “C” button to delete the selected pattern and the following patterns in the program will move back.

Recall and sew the memorized pattern

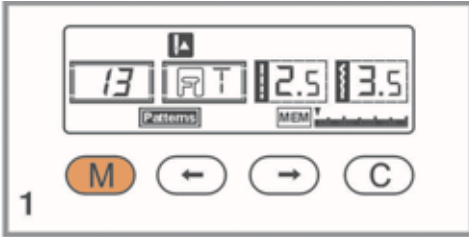

1. Press the “M” button to enter the memory mode. The machine will be positioned at the first programmed stitch.

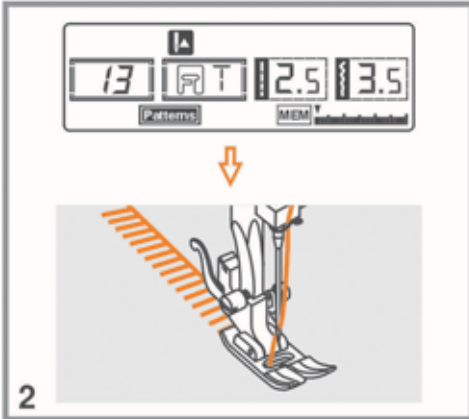

2. Press foot control. The machine will start to sew from first entered pattern. On the LCD screen, sewing stitch data is indicated.

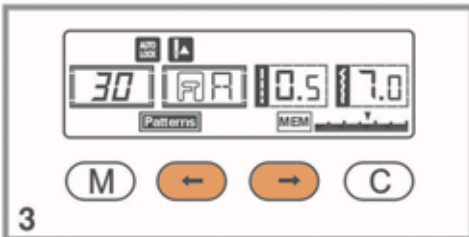

3. If you wish to check what is programmed or if you wish to start sewing a few stitches in the memory, use the “←” button or “→” button.
You can use the Auto-lock “⊙” function when the sewing machine is stopped.



Please Note: If you wish to repeat your stitch combination without having the machine stop press the Auto-lock “⊙” button to cancel the Auto-Stop in the memory mode. The “⊙” will disappear from the LCD screen.

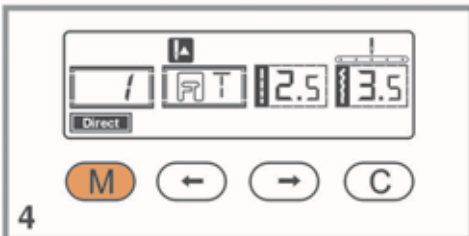

4. Press the “M” button to leave the memory mode and return to the Direct mode.

WARNING FUNCTIONS

Warning animation message display

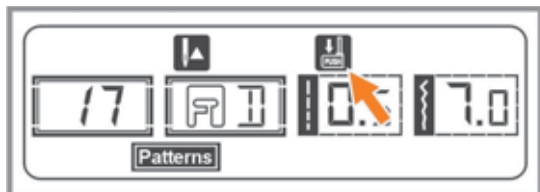

Buttonhole lever is not lowered

The buttonhole or darning stitch was selected and the foot control pressed while the buttonhole lever was raised.

Instruction animation message display

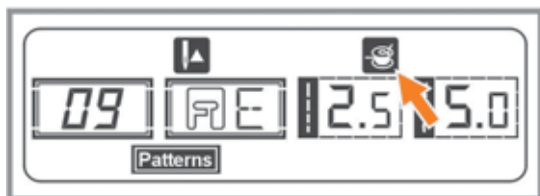

Bobbin winding

The bobbin winder is engaged.

Warning beeping sound

- When operating correctly: 1 beep.
- When the memory is full 30 units of pattern: 2-short beeps.
- When operating incorrectly: 3-short beeps.
- When the sewing machine is thread locked and can't sew: 8 seconds short beeps.

It means that the thread is twisted or caught and the hand wheel can't move. Please look through the Troubleshooting guide to find the solution. After the problem has been solved, the machine will continue to sew.

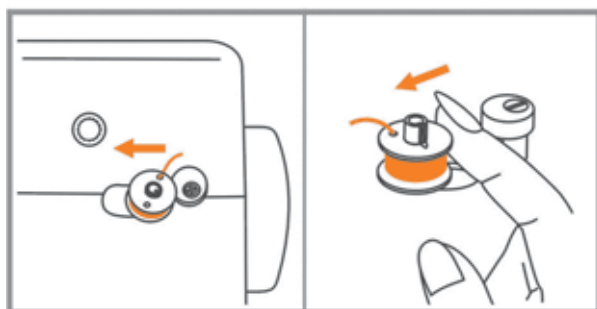

Push bobbin winder stop to sewing position

If you have not pushed back the bobbin to the left when the bobbin is full and press any button or try to sew, the machine will give a warning sound of 3 beeps.

 **Please Note:** If the problem is still not solved, please contact your local dealer.



Attention: During the sewing, if the thread is caught or wrapped inside the hook stopping the needle from moving and you continue pressing the foot control, the security switch will stop the machine completely. In order to restart the sewing machine, clean out the thread that is caught then turn OFF the on/off switch and then ON again.

REPLACING THE LIGHT BULB



Attention: Turn the power switch off and wait until the light bulb has cooled before touching it.

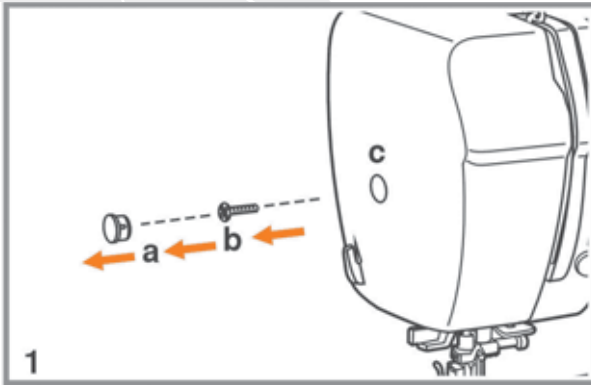

1. Remove plug (a) , loosen the screw (b) on the left side of the sewing machine and remove the face plate (c).

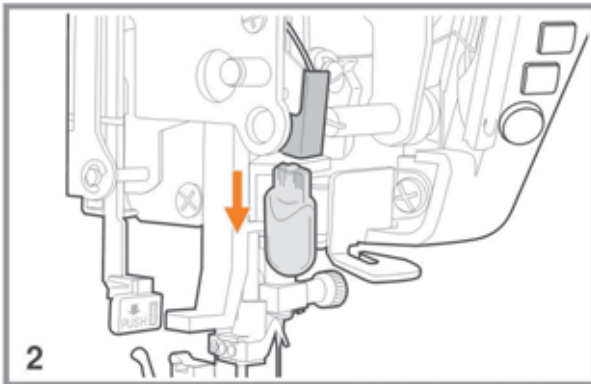

2. Replace the bulb as follows:
Pull light bulb downward to remove.
Replace the bulb with same type rated 12V/5W.
Replace the face plate and tighten the screw.

MAINTENANCE

⚠ Attention: Disconnect the power cord from the wall socket before cleaning the screen and sewing machine surface, otherwise injury or electrical shock may result.



Cleaning the screen

If the front panel is dirty, wipe it gently with a soft, dry cloth.

Do not use any organic solvents or detergents.

Cleaning the sewing machine surface

If the surface of the sewing machine is dirty, lightly soak a cloth in mild detergent, squeeze it out firmly and then wipe the surface. After cleaning it once in this way, wipe the surface again with a dry cloth.

Cleaning the hook

If lint and bits of thread accumulate in the hook, this will interfere with the smooth operation of the machine. Check regularly and clean the stitching mechanism when necessary.

⚠ Attention: Disconnect the machine from the wall outlet before carrying out any maintenance.

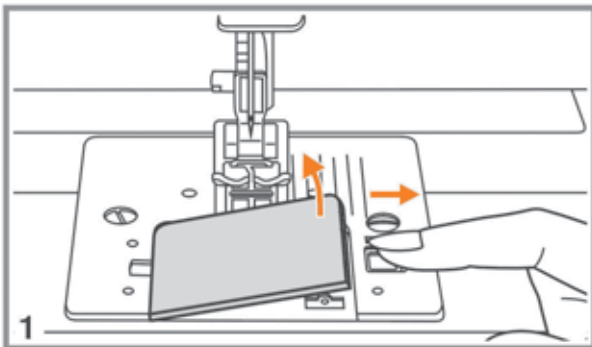

1. Remove the bobbin cover plate and bobbin.

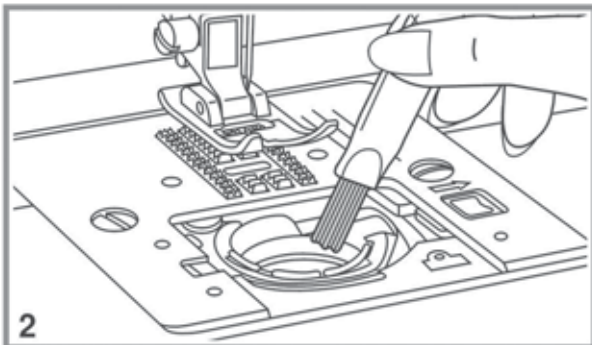

2. Clean the bobbin holder with a brush.

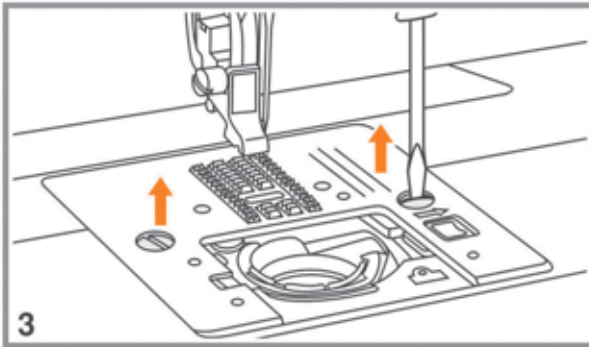

3. Remove the needle, presser foot and presser foot holder. Remove the bobbin cover plate and bobbin. Remove the screw holding the needle plate and remove the needle plate.

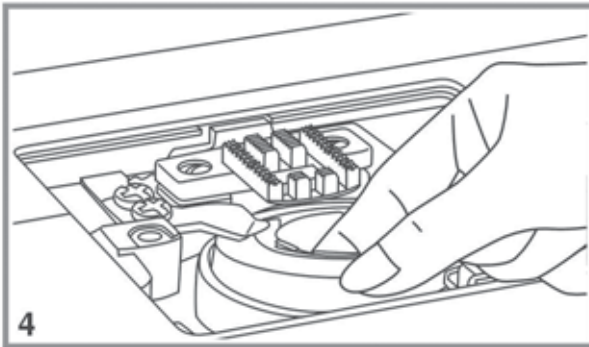

4. Lift up the bobbin case and remove it.

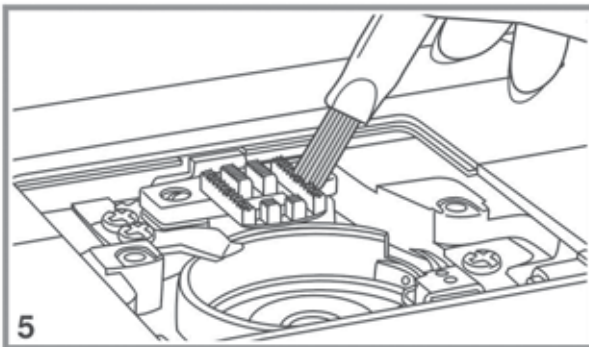

5. Clean the hook race, feed dog and bobbin case with a brush. Also clean them, using a soft, dry cloth.

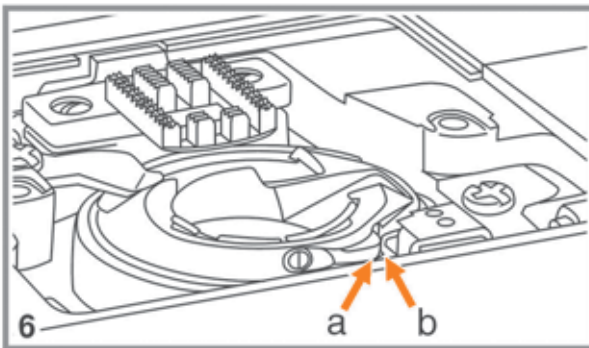

6. Replace the bobbin case into the hook race so that the tip (a) fits to the stopper (b) as shown.

7. Replace all other parts.

TROUBLESHOOTING GUIDE

Before calling for service, check the following items. If the problem still persists, contact the place of purchase or your nearest authorized dealer.















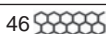

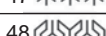
Problem	Cause	Correction
Upper thread breaks	1.The machine is not threaded correctly.	1.Rethread the machine.
	2.The thread tension is too tight.	2.Reduce the thread tension (lower number).
	3.The thread is too thick for the needle.	3.Select a larger needle.
	4.The needle is not inserted correctly.	4.Remove and reinsert the needle (flat side towards the back).
	5.The thread is wound around the spool holder pin.	5.Remove the spool and wind thread onto spool.
	6.The needle is damaged.	6.Replace the needle.
Lower thread breaks	1.The bobbin case is not inserted correctly.	1.Remove and reinsert the bobbin case and pull on the thread. The thread should pull easily.
	2.The bobbin case is threaded wrong.	2.Check both bobbin and bobbin case.
	3.The lower thread tension is too tight	3.Loosen lower thread tension.
Skipped stitches	1.The needle is not inserted correctly.	1.Remove and reinsert needle (flat side towards the back).
	2.The needle is damaged.	2.Insert a new needle.
	3.The wrong size needle has been used.	3.Choose a needle to suit the thread.
	4.The foot is not attached correctly.	4.Check and attach correctly.
	5.The machine is not threaded correctly.	5.Rethread the machine.
	6.The presser foot pressure is not correct.	6.Increase the presser foot pressure.
Needle breaks	1.The needle is damaged.	1.Insert a new needle.
	2.The needle is not correctly inserted.	2.Insert the needle correctly (flat side towards the back).
	3.Wrong needle size for the fabric.	3.Choose a needle to suit the thread and fabric.
	4.The wrong foot is attached.	4.Select the correct foot.
	5.The needle clamp screw is loose.	5.Use the screwdriver to firmly tighten the screw.
	6.The presser foot that is used is not appropriate for the type of stitch that you wish to sew.	6.Attach the presser foot that is appropriate for the type of stitch that you wish to sew.
	7.The upper thread tension is too tight.	7.Loosen the upper thread tension.
Loose stitches	1.The machine is not correctly threaded.	1.Check the threading.
	2.The bobbin case is not correctly threaded.	2.Thread the bobbin case as illustrated.
	3.Needle/fabric/thread combination is wrong.	3.The needle size must suit the fabric and thread.
	4.Thread tension is wrong.	4.Correct the thread tension.
Seam gather or pucker	1.The needle is too thick for the fabric.	1.Select a finer needle.
	2.The stitch length is adjusted wrong.	2.Shorten the stitch length.
	3.The thread tension is too tight.	3.Loosen the thread tension.

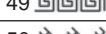
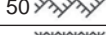
Problem	Cause	Correction
Seam puckering	1.The needle thread tension is too tight.	1. Loosen the thread tension.
	2.The needle thread is not threaded correctly.	2. Rethread the machine.
	3.The needle is too heavy for the fabric being sewn.	3. Choose a needle to suit the thread and fabric.
	4.The stitch length is too long for the fabric.	4. Shorten stitch length.
	5.The presser foot pressure is not correctly adjusted.	5. Decrease the presser foot pressure.
Patterns are distorted	1.The correct presser foot is not used.	1. Select the correct foot.
	2.The needle thread tension is too tight.	2. Loosen the thread tension.
The machine jams	1.Thread is caught in the hook.	Remove the upper thread and bobbin case, turn the handwheel backwards and forwards by hand and remove the thread and lint.
	2.The feed dogs are packed with lint.	
The machine is noisy	1.Lint or oil have collected on the hook or needle bar.	1.Clean the hook and feed dog as described.
	2.Poor quality oil has been used.	2.Only use good quality sewing machine oil.
	3.The needle is damaged.	3.Replace the needle.
	4.Humming sound coming from internal motor.	4.Normal.
	5.Thread is caught in the hook.	Remove the upper thread and bobbin case, turn the handwheel backwards and forwards by hand and remove the thread and lint.
	6.The feed dogs are packed with lint.	
Uneven stitches, uneven feed	1.Poor quality thread.	1.Select a better quality thread.
	2.The bobbin case is threaded wrong.	2.Remove the bobbin case, the thread and reinsert correctly.
	3.Fabric has been pulled.	3.Do not pull on the fabric while sewing, let it be fed by the feed dogs.
The sewing machine does not operate	1.The machine is not turned on.	1.Turn on the machine.
	2.The presser foot lever is raised.	2.Lower the presser foot lever.
	3.The machine is not plugged in.	3.Connect the power line plug to the electric outlet.

QUICK REFERENCE CHART - MODEL C10

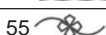









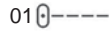

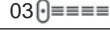
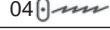
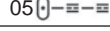
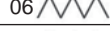
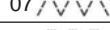

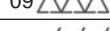
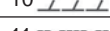
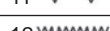
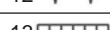
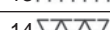

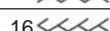
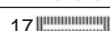







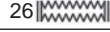





Pattern		Width (mm)		Length (mm)		Presser Foot	Functions				
		Auto	Manual	Auto	Manual		Reverse	Auto-lock	Mirror/Presser foot	Twin needle	Memory
Utility stitches	01	3.5	0.0~7.0	2.5	0.0~4.5	T	*	*	*	*	*
	02	0.0	0.0~7.0	2.5	0.0~4.5	T	*	*	*	*	*
	03	3.5	0.0~7.0	2.5	1.0~3.0	T	*	*	*	*	*
	04	3.5	1.0~6.0	2.5	1.0~3.0	T	*	*	*	*	*
	05	3.5	0.0~7.0	2.5	1.5~3.0	T	*	*	*	*	*
	06	5.0	0.0~7.0	2.0	0.3~4.5	T	*	*	*	*	*
	07	5.0	2.0~7.0	1.0	0.3~4.5	T	*	*	*	*	*
	08	5.0	2.5~7.0	2.5	1.0~3.0	T	*	*	*	*	*
	09	5.0	3.5~7.0	2.5	1.0~3.0	E	*	*	*/T	*	*
	10	5.0	2.5~7.0	2.5	1.0~3.0	T	*	*	*	*	*
	11	3.5	2.5~7.0	2.0	0.5~4.5	F	*	*	*/T	*	*
	12	3.5	2.5~7.0	1.0	0.5~4.5	F	*	*	*/T	*	*
	13	3.5	2.5~7.0	2.5	1.5~3.0	T	*	*	*	*	*
	14	5.0	2.5~7.0	2.5	1.0~3.0	T	*	*	*	*	*
	15	7.0	2.5~7.0	2.5	1.0~3.0	A	*	*	*	*	*
	16	5.0	2.5~7.0	2.5	1.0~3.0	A	*	*	*	*	*
Buttonhole stitches	17	5.0	2.5~7.0	0.5	0.3~1.0	D					
	18	5.5	3.0~7.0	0.5	0.3~1.0	D					
	19	5.0	2.5~5.5	0.5	0.3~1.0	D					
	20	6.0	3.0~7.0	0.5	0.3~1.0	D					
	21	5.0	2.5~5.5	0.5	0.3~1.0	D					
	22	5.0	2.5~5.5	0.5	0.3~1.0	D					
	23	7.0	5.5~7.0	0.5	0.3~1.0	D					
	24	7.0	5.5~7.0	0.5	0.3~1.0	D					
	25	7.0	5.5~7.0	0.5	0.3~1.0	D					
	26	6.0	3.0~7.0	1.0	1.0~2.0	D					
	27	6.0	3.0~7.0	1.5	1.0~3.0	D					
28	7.0	7.0,6.0,5.0			A						
29	7.0	3.5~7.0	2.0	1.0~2.0	D						
Satin stitches	30	7.0	2.5~7.0	0.5	0.3~1.0	A	*	*	*	*	*
	31	7.0	2.5~7.0	0.5	0.3~1.0	A	*	*	*	*	*
	32	7.0	2.5~7.0	0.5	0.3~1.0	A	*	*	*	*	*
	33	7.0	2.5~7.0	0.5	0.3~1.0	A	*	*	*	*	*
	34	7.0	2.5~7.0	0.5	0.3~1.0	A	*	*	*	*	*
	35	7.0	2.5~7.0	0.5	0.3~1.0	A	*	*	*	*	*
	36	7.0	2.5~7.0	0.5	0.3~1.0	A	*	*	*	*	*
	37	7.0	4.0~7.0	0.5	0.5~1.0	A	*	*	*	*	*
	38	7.0	2.5~7.0	0.5	0.5~1.0	A	*	*	*	*	*
	39	7.0	4.0~7.0	0.5	0.5~1.0	A	*	*	*	*	*
40	5.0	2.5~7.0	2.5	1.0~3.0	A	*	*	*	*	*	

* Adjustments can be made.







































Pattern		Width (mm)		Length (mm)		Presser Foot	Functions				
		Auto	Manual	Auto	Manual		Reverse	Auto-lock	Mirror/Presser foot	Twin needle	Memory
Cross stitches	41 	6.0	5.0~7.0	1.0	1.0~3.0	A	*	*	*	*	*
	42 	6.0	3.0~7.0	1.0	1.0~3.0	A	*	*	*	*	*
	43 	6.0	3.0~7.0	1.0	1.0~3.0	A	*	*	*	*	*
Decorative stitches	44 	5.0	2.5~7.0	2.5	1.5~3.0	T	*	*	*	*	*
	45 	5.0	2.5~7.0	2.5	1.5~3.0	T	*	*	*	*	*
	46 	7.0	3.0~7.0	2.0	1.0~3.0	T	*	*	*	*	*
	47 	5.0	3.0~7.0	2.5	1.5~4.5	A	*	*	*	*	*
	48 	7.0	2.5~7.0	2.0	1.0~3.0	T	*	*	*/A	*	*
	49 	5.0	2.5~7.0	2.5	1.5~3.0	T	*	*	*/A	*	*
	50 	7.0	2.5~7.0	1.5	1.0~3.0	A	*	*	*	*	*
	51 	6.0	3.5~7.0	1.5	1.5~3.0	A	*	*	*	*	*
	52 	7.0	2.5~7.0	2.5	1.0~4.5	T	*	*	*	*	*
	53 	5.0	4.5~7.0	1.0	1.0~3.0	A	*	*	*	*	*
	54 	7.0	3.0~7.0	3.0	2.0~3.0	A	*	*	*	*	*
	55 	7.0	3.5~7.0	2.5	1.5~3.0	T	*	*	*	*	*
	56 	7.0	2.5~7.0	3.0	1.5~3.0	A	*	*	*	*	*
	57 	7.0	3.0~7.0	2.0	2.0~3.0	A	*	*	*	*	*
	58 	7.0	2.5~7.0	2.0	1.5~3.0	T	*	*	*/T	*	*
	59 	7.0	4.0~7.0	3.0	2.0~3.0	T	*	*	*/T	*	*
	60 	5.0	2.5~7.0	2.0	1.0~3.0	T	*	*	*	*	*

* Adjustments can be made.

QUICK REFERENCE CHART - MODEL C20

Pattern		Width (mm)		Length (mm)		Presser Foot	Functions				
		Auto	Manual	Auto	Manual		Reverse	Auto-lock	Mirror/Presser foot	Twin needle	Memory
Utility stitches	01 	3.5	0.0~7.0	2.5	0.0~4.5	T	*	*	*	*	*
	02 	0.0	0.0~7.0	2.5	0.0~4.5	T	*	*	*	*	*
	03 	3.5	0.0~7.0	2.5	1.0~3.0	T	*	*	*	*	*
	04 	3.5	1.0~6.0	2.5	1.0~3.0	T	*	*	*	*	*
	05 	3.5	0.0~7.0	2.5	1.5~3.0	T	*	*	*	*	*
	06 	5.0	0.0~7.0	2.0	0.3~4.5	T	*	*	*	*	*
	07 	5.0	2.0~7.0	1.0	0.3~4.5	T	*	*	*	*	*
	08 	5.0	2.5~7.0	2.5	1.0~3.0	T	*	*	*	*	*
	09 	5.0	3.5~7.0	2.5	1.0~3.0	E	*	*	*/T	*	*
	10 	5.0	2.5~7.0	2.5	1.0~3.0	T	*	*	*	*	*
	11 	3.5	2.5~7.0	2.0	0.5~4.5	F	*	*	*/T	*	*
	12 	3.5	2.5~7.0	1.0	0.5~4.5	F	*	*	*/T	*	*
	13 	3.5	2.5~7.0	2.5	1.5~3.0	T	*	*	*	*	*
	14 	5.0	2.5~7.0	2.5	1.0~3.0	T	*	*	*	*	*
	15 	7.0	2.5~7.0	2.5	1.0~3.0	A	*	*	*	*	*
	16 	5.0	2.5~7.0	2.5	1.0~3.0	A	*	*	*	*	*
Buttonhole stitches	17 	5.0	2.5~7.0	0.5	0.3~1.0	D					
	18 	5.5	3.0~7.0	0.5	0.3~1.0	D					
	19 	5.0	2.5~5.5	0.5	0.3~1.0	D					
	20 	6.0	3.0~7.0	0.5	0.3~1.0	D					
	21 	5.0	2.5~5.5	0.5	0.3~1.0	D					
	22 	5.0	2.5~5.5	0.5	0.3~1.0	D					
	23 	7.0	5.5~7.0	0.5	0.3~1.0	D					
	24 	7.0	5.5~7.0	0.5	0.3~1.0	D					
	25 	7.0	5.5~7.0	0.5	0.3~1.0	D					
	26 	6.0	3.0~7.0	1.0	1.0~2.0	D					
	27 	6.0	3.0~7.0	1.5	1.0~3.0	D					
	28 	7.0	7.0,6.0,5.0			A					
29 	7.0	3.5~7.0	2.0	1.0~2.0	D						
Satin stitches	30 	7.0	2.5~7.0	0.5	0.3~1.0	A	*	*	*	*	*
	31 	7.0	2.5~7.0	0.5	0.3~1.0	A	*	*	*	*	*
	32 	7.0	2.5~7.0	0.5	0.3~1.0	A	*	*	*	*	*
	33 	7.0	2.5~7.0	0.5	0.3~1.0	A	*	*	*	*	*
	34 	7.0	2.5~7.0	0.5	0.3~1.0	A	*	*	*	*	*
	35 	7.0	2.5~7.0	0.5	0.3~1.0	A	*	*	*	*	*
	36 	7.0	2.5~7.0	0.5	0.3~1.0	A	*	*	*	*	*
	37 	7.0	4.0~7.0	0.5	0.5~1.0	A	*	*	*	*	*
	38 	7.0	2.5~7.0	0.5	0.5~1.0	A	*	*	*	*	*
	39 	7.0	4.0~7.0	0.5	0.5~1.0	A	*	*	*	*	*
	40 	7.0	2.5~7.0	0.5	0.3~1.0	A	*	*	*	*	*

* Adjustments can be made.

Pattern		Width (mm)		Length (mm)		Presser Foot	Functions				
		Auto	Manual	Auto	Manual		Reverse	Auto-lock	Mirror/Presser foot	Twin needle	Memory
Satin stitches	41 	7.0	2.5~7.0	0.5	0.3~1.0	A	*	*	*	*	*
	42 	7.0	2.5~7.0	0.5	0.3~1.0	A	*	*	*	*	*
	43 	7.0	2.5~7.0	0.5	0.3~1.0	A	*	*	*	*	*
	44 	7.0	2.5~7.0	0.5	0.3~1.0	A	*	*	*	*	*
	45 	7.0	2.5~7.0	0.5	0.3~1.0	A	*	*	*	*	*
	46 	7.0	2.5~7.0	0.5	0.3~1.0	A	*	*	*	*	*
	47 	7.0	2.5~7.0	0.5	0.3~1.0	A	*	*	*	*	*
	48 	7.0	2.5~7.0	0.5	0.3~1.0	A	*	*	*/A	*	*
	49 	7.0	2.5~7.0	0.5	0.3~1.0	A	*	*	*/A	*	*
	50 	7.0	2.5~7.0	0.5	0.3~1.0	A	*	*	*	*	*
	51 	7.0	2.5~7.0	0.5	0.3~1.0	A	*	*	*	*	*
Cross Stitches	52 	5.0	2.5~7.0	2.5	1.0~3.0	A	*	*	*	*	*
	53 	6.0	5.0~7.0	1.0	1.0~3.0	A	*	*	*	*	*
	54 	6.0	3.0~7.0	1.0	1.0~3.0	A	*	*	*	*	*
	55 	6.0	3.0~7.0	1.0	1.0~3.0	A	*	*	*	*	*
	56 	4.0	3.0~7.0	1.0	1.0~3.0	A	*	*	*	*	*
Decorative stitches	57 	5.0	2.5~7.0	2.5	1.5~3.0	T	*	*	*	*	*
	58 	5.0	2.5~7.0	2.5	1.5~3.0	T	*	*	*/T	*	*
	59 	7.0	3.0~7.0	2.0	1.0~3.0	T	*	*	*/T	*	*
	60 	5.0	3.0~7.0	2.5	1.5~4.5	A	*	*	*	*	*
	61 	7.0	2.5~7.0	2.0	1.0~3.0	T	*	*	*	*	*
	62 	5.0	2.5~7.0	2.5	1.5~3.0	T	*	*	*	*	*
	63 	7.0	2.5~7.0	1.5	1.0~3.0	A	*	*	*	*	*
	64 	6.0	3.5~7.0	1.5	1.5~3.0	A	*	*	*	*	*
	65 	7.0	2.5~7.0	2.5	1.0~4.5	T	*	*	*	*	*
	66 	5.0	4.5~7.0	1.0	1.0~3.0	A	*	*	*	*	*
	67 	7.0	3.0~7.0	3.0	2.0~3.0	A	*	*	*	*	*
	68 	7.0	3.5~7.0	2.5	1.5~3.0	T	*	*	*	*	*
	69 	7.0	2.5~7.0	3.0	1.5~3.0	A	*	*	*	*	*
	70 	7.0	3.0~7.0	2.0	2.0~3.0	A	*	*	*	*	*
	71 	7.0	2.5~7.0	2.0	1.5~3.0	T	*	*	*	*	*
	72 	7.0	4.0~7.0	3.0	2.0~3.0	T	*	*	*	*	*
	73 	5.0	2.5~7.0	2.0	1.0~3.0	T	*	*	*	*	*
	74 	6.0	2.5~7.0	2.0	1.5~3.0	A	*	*	*	*	*
	75 	7.0	3.5~7.0	2.0	1.5~3.0	A	*	*	*	*	*
76 	7.0	2.5~7.0	1.5	1.0~3.0	A	*	*	*	*	*	
77 	7.0	2.5~7.0	2.0	1.5~3.0	A	*	*	*	*	*	
78 	5.0	3.5~7.0	3.0	1.5~3.0	A	*	*	*	*	*	
79 	5.0	4.5~7.0	2.0	2.0~3.0	A	*	*	*	*	*	

* Adjustments can be made.



Please note that on disposal, this product must be safely recycled in accordance with relevant National legislation relating to electrical/electronic products. If in doubt please contact your retailer for guidance.



Free Manuals Download Website

<http://myh66.com>

<http://usermanuals.us>

<http://www.somanuals.com>

<http://www.4manuals.cc>

<http://www.manual-lib.com>

<http://www.404manual.com>

<http://www.luxmanual.com>

<http://aubethermostatmanual.com>

Golf course search by state

<http://golfingnear.com>

Email search by domain

<http://emailbydomain.com>

Auto manuals search

<http://auto.somanuals.com>

TV manuals search

<http://tv.somanuals.com>