

KODAK ESP Office 2100 Series All-in-One Printers



Extended User Guide

Kodak

Eastman Kodak Company
Rochester, NY 14650

© Eastman Kodak Company, 2011

Kodak, EasyShare, ESP, and Perfect Touch are trademarks of Eastman Kodak Company.

Specifications subject to change without notice.

February 2011

Table of contents

1 Printer Overview

Components.....	9
Control panel.....	10
Home Center Software	11
Ordering supplies.....	12
Configuring printer settings	12
Online Printer Management Tool.....	13
Accessing the Online Printer Management Tool.....	14
Using the Online Printer Management Tool to configure your printer's settings	14

2 Networking Your Printer

Connecting to a wireless network	15
Before you connect	15
Connecting to a wireless network using the Wi-Fi Setup Wizard.....	15
Setting up an IP address.....	19
Viewing the network configuration.....	20
Printing the network configuration	20
Changing the printer name	20
Installing your printer on additional computers on the network.....	21
Connecting to another KODAK All-in-One Printer	21
Adding a wireless network connection to a USB-connected computer.....	22
Changing from USB to a wireless connection	22

3 Handling Paper

Paper types.....	24
Paper sizes.....	24
Envelope sizes.....	25
Loading paper	25
Loading plain paper.....	26
Loading photo paper	27
Loading envelopes.....	28
Loading originals	29
Using the scanner glass	29
Using the Automatic Document Feeder (ADF).....	30

4 Printing

Printing documents	31
Printing two-sided documents	31
Printing forms	33
Printing pictures	33
Viewing pictures on a memory card or USB-connected device.....	34
Printing from a memory card or USB-connected device.....	35

Printing from a wireless device	40
Transferring pictures to a computer.....	41
Transferring pictures to a computer with WINDOWS OS.....	41
Transferring pictures to a computer with MAC OS.....	41
5 Copying	
Loading originals for copying.....	42
Copying a document.....	42
Using the default settings to copy a document.....	42
Adjusting the settings and copying a document.....	42
Changing the number of copies of a document	44
Enlarging or reducing a document	44
Darkening or lightening a copy	44
Copying a photograph.....	45
Using the default settings to copy a photograph.....	45
Adjusting the settings and copying a photograph.....	45
Changing the number of copies of a photograph.....	47
Enlarging or reducing a photograph	47
Darkening or lightening a copy of a photograph	47
6 Scanning	
Before you begin scanning	48
Changing the scan settings for scanning from the printer control panel.....	48
Adding a profile and address book for Scan To Email	51
Adding a profile for Scan To Network Folder.....	53
Loading originals for scanning.....	55
Scanning from the computer	56
Scanning multiple pictures simultaneously.....	56
Scanning from the control panel.....	57
Scanning from the Online Printer Management Tool	59
7 Faxing	
Before you begin faxing.....	60
Connecting the printer for faxing	60
Entering fax sender information	64
Setting fax options	65
Working with the phonebook.....	68
Preparing a fax for transmission.....	71
Printing a fax cover page	71
Loading originals.....	71
Changing resolution and brightness.....	72

Sending a fax	72
Using the phonebook to send a fax.....	72
Using Quick Dial to send a fax	73
Using the numeric keypad to send a fax.....	73
Using the Redial button to send a fax.....	73
Receiving a fax	73
Receiving a fax automatically	73
Receiving a fax manually	74
Printing fax reports	74
Fax settings report.....	74
Fax confirmation page.....	75
Fax activity log.....	75
Canceling a fax	75
8 Maintaining Your Printer	
General care and cleaning	76
Cleaning the scanner glass and document backing.....	77
Replacing ink cartridges	79
Updating the software and printer firmware.....	82
Updating manually if your printer is connected to a computer with WINDOWS OS.....	82
Updating manually if your printer is connected to a computer with MAC OS	83
Monitoring and adjusting printer performance	84
Checking ink levels	84
Resetting factory defaults	84
Replacing the printhead	85
9 Troubleshooting	
Basic troubleshooting	89
Getting help on the Web.....	91
Status lights.....	92
Power light.....	92
Wi-Fi connectivity LED	92

10 Product and Safety Specifications

Features and Specifications	93
Print performance	93
Photo printing features	93
Copy document features	94
Copy photo features	94
Scanning features	94
Faxing features and specifications	95
Paper input tray	95
Automatic Document Feeder (ADF) for originals	95
Ink cartridges	95
Connectivity	95
Software support	96
Physical specifications	96
Warranty	96
Minimum System requirements	97
Safety information	100
Regulatory compliance	101
FCC statement	101
Canadian statements	102
European compliance statement	102
German compliance statement	102
REACH Article 33 declarations	103
Power supply information	103
Waste electrical and electronic equipment labeling	103
ENERGY STAR® Qualified	103
Warranty Information	103
Declaration of Conformity	105

1

Printer Overview

This printer lets you print, copy, scan, and fax pictures and documents.

Components

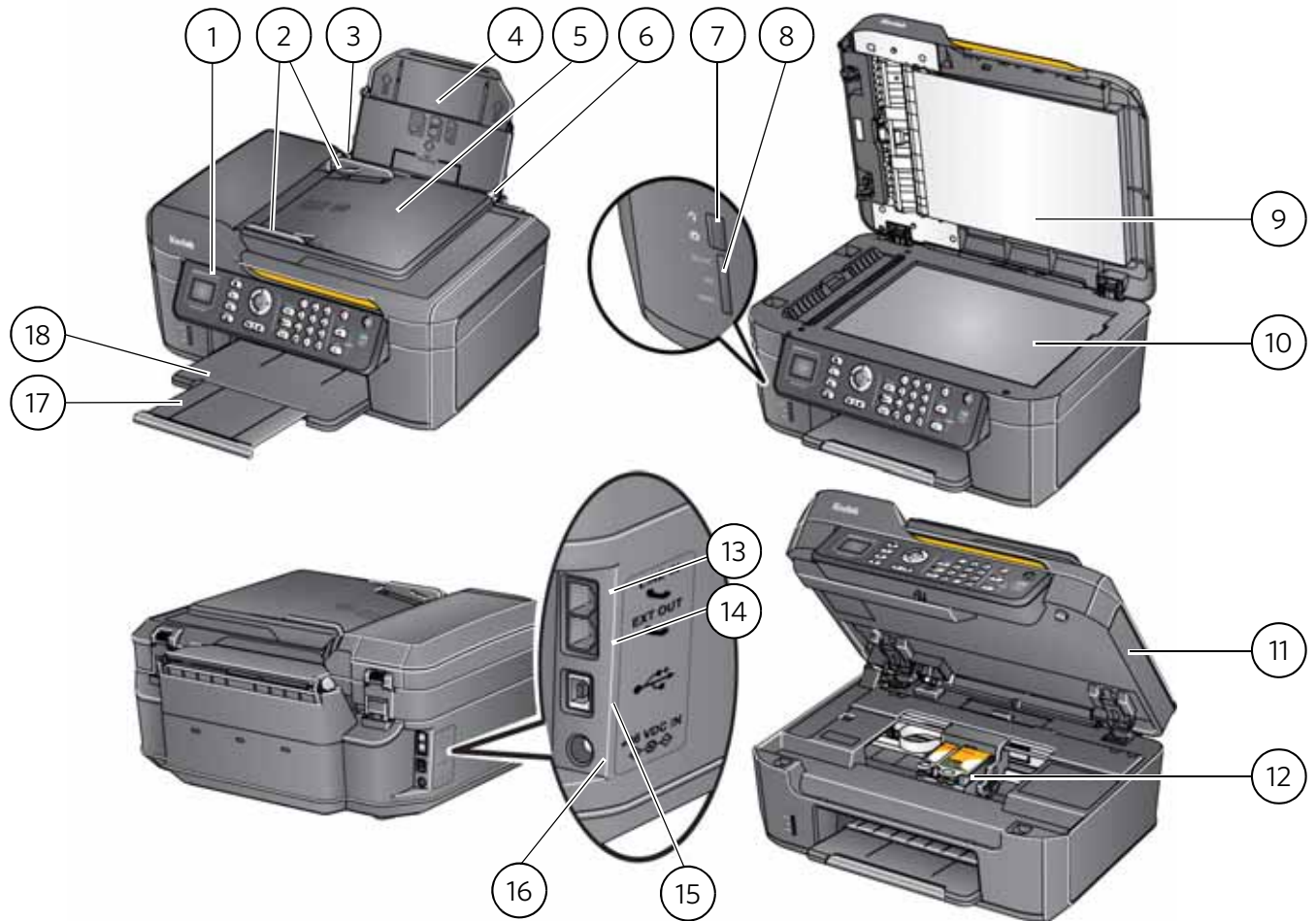

- | | | | |
|---|---|----|---|
| 1 | Control panel | 10 | Scanner glass |
| 2 | ADF paper-edge guides | 11 | Access door |
| 3 | Left paper-edge guide | 12 | Printhead with ink cartridges installed |
| 4 | Paper input tray | 13 | Line in phone port |
| 5 | Automatic document feeder (ADF) | 14 | Ext out phone port |
| 6 | Right paper-edge guide | 15 | USB port (for connecting to computer) |
| 7 | Front USB port (ESP Office 2170 printer only) | 16 | Power cord connection port |
| 8 | Memory card slot | 17 | Output tray extender |
| 9 | Scanner lid | 18 | Output tray |

Control panel

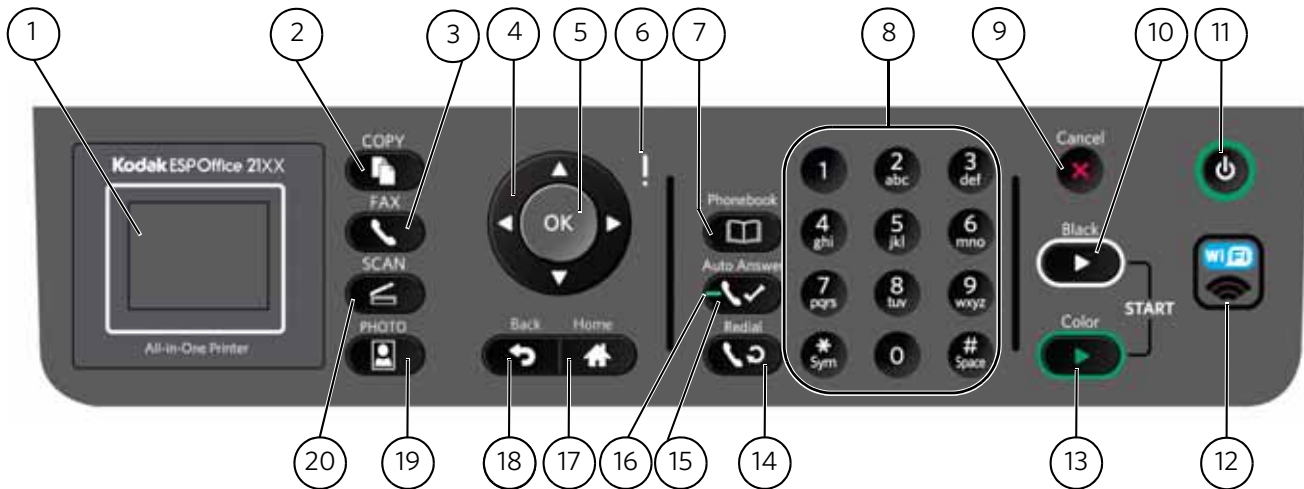

Feature

- 1 LCD
- 2 Copy mode button
- 3 Fax mode button
- 4 Navigation buttons
- 5 OK button
- 6 Attention light
- 7 Phonebook button
- 8 Numeric keypad
- 9 Cancel button
- 10 Start Black button
- 11 Power button
- 12 Wi-Fi connectivity LED
- 13 Start Color button
- 14 Redial button
- 15 Auto Answer button
- 16 Auto answer LED
- 17 Home button
- 18 Back button
- 19 Photo mode button
- 20 Scan mode button

Description

- Displays pictures, messages, and menus
- Displays the Copy Options menu
- Lets you enter a phone number for sending a fax, or choose the Fax Options menu
- Used to navigate menus and scroll through pictures
- Selects a menu item, accepts a setting, and continues with the current operation
- Blinks when an error occurs
- Displays the phonebook of fax numbers entered on this printer; lets you enter or edit phone numbers
- Used to dial a phone number or a Quick Dial number for faxing; to enter information and Quick Dial settings into the fax phonebook; to specify a quantity for making copies; and to enter information for authenticating access to a network
- Stops the current operation and returns to the menu; clears certain errors to allow scanning or sending a fax
- Starts the selected operation in black and white
- Turns the printer on or off
- When lit, signals that the printer is connected to a wireless (Wi-Fi) network; blinks when searching for an available Wi-Fi network or when the existing signal is too weak to transmit or receive wireless signals
- Starts the selected operation in color, if the source is in color
- Dials the last-dialed phone number
- Turns the fax auto answer feature on or off; when on, the fax answers all incoming calls automatically
- Lights when the fax auto answer feature is on
- Displays the main menu
- Displays the next higher screen in the menu structure
- Displays the Print Photo Options menu
- Displays the Scan Options menu

Home Center Software

KODAK Home Center Software is installed with your KODAK All-in-One Printer Software, unless you choose otherwise. The Home Center icon will appear on your desktop.



On a computer with WINDOWS Operating System (OS), you can use Home Center Software to:

- browse, crop, enhance, and edit pictures
- print and scan
- make 3D anaglyphs
- print from video
- send images to or print images from KODAK Gallery
- send images to or print images from FACEBOOK Social Network, FLICKR, PHOTOBUCKET, PICASA, or SMILEBOX Photo Management Systems
- configure your printer
- install new network printers
- upgrade to the latest printer software and firmware
- order supplies
- access the KODAK Tips and Projects Center
- access this Extended User Guide

On a computer with MAC OS, you can use Home Center Software to:

- scan
- configure your printer
- upgrade to the latest printer software and firmware
- order supplies
- see the status of your printer
- access this Extended User Guide

Ordering supplies

You can order ink cartridges, paper, and accessories online.

To order supplies, make sure that your computer is connected to the Internet, then:

1. Open Home Center Software.
2. Select **Order Supplies** (on a computer with WINDOWS OS) or select the **Tools** tab, then click **Order Supplies** (on a computer with MAC OS).
3. Select the item(s) you want to buy, then follow the on-screen instructions.

Configuring printer settings

To set or change basic printer settings:

1. Press **Home**.
2. Press ▼ to select **Printer Settings**, then press **OK**.
3. Press ▼ to select one of the following settings:
 - **Date and Time**
 - Press **OK**, then press ▼ to select **Year, Month, Day, Hour, or Minute**.
 - Press ◀ or ▶ to change the values; press **OK** when you are done making changes.
 - Press **Back** to go back to the Printer Settings menu.
 - **Time to Low Power**

To conserve energy, your printer will enter a low power (sleep) mode after being idle for a default delay time of 1 hour. You can increase the delay time to low power (in 0.5 hour increments) up to 4 hours. Increasing the delay time may result in reduced energy savings.

 - Press ▶ to change the time to energy-saving sleep mode (select from 1 to 4 hours in 0.5 hour increments).
 - **Tagged Images Printing** (see [Printing tagged pictures, page 40](#))
 - Press ▶ to select **Off** or **On**.
 - **Language**
 - Press **OK**, press ▼ to select a language, then press **OK**.
 - **Country/Region**
 - Press **OK**, press ▼ to select a country or region, then press **OK**.
 - **Reset All Settings** (see [Resetting factory defaults, page 84](#))

NOTE: Resetting factory defaults does not change the date and time, language, country/region, or network settings.
 - **Printer Info**
 - Press **OK** to view the Firmware Version number; press **OK** when you are done.
4. Press **Back** to return to the Main Menu.

Online Printer Management Tool

Your printer includes a feature that enables you to view the printer status, change settings, and capture scans using an Internet browser on any computer that is on the same network as your printer, independent of Home Center Software. The Online Printer Management Tool also allows you to scan to an email address or to a network folder.

The screenshot shows the KODAK Online Printer Management Tool interface. At the top left is the Kodak logo and the text "KODAK ESP Office 2150 Series". Below this is a navigation menu with tabs for "Home", "Device", "Settings", "Network", "Applications", and "Links". The "Home" tab is selected. The main content area displays a welcome message: "Welcome to the KODAK Online Printer Management Tool" and a sub-message: "This tool helps you manage the printer from your computer using a Web browser. You can use it to view status information and change settings." Below this is a section titled "Device Information" containing a table with the following data:

Product Name	KODAK ESP Office 2150 Series
KODAK Service Number	LDV2069
Firmware Version	RC1.2

Below the table are two icons: "Printer Image" showing a photograph of the printer, and "Ink Levels" showing two ink cartridges (black and cyan). At the bottom left, the status is indicated as "Status : Ready".

Accessing the Online Printer Management Tool

If you have a computer with WINDOWS 7 Operating System with Home Center Software installed:

1. Select **Start > Control Panel > Devices and Printers**.
2. Click the **Printer Management** icon.

If you have a computer with WINDOWS 7 Operating System without Home Center Software installed, or if you have a computer with WINDOWS XP or WINDOWS VISTA Operating Systems or any version of MAC OS:

1. Determine the IP address of your wirelessly connected printer:
 - a. On your printer control panel, press **Home**.
 - b. Use the down arrow to select **Network Settings**, then press **OK**.
 - c. Use the down arrow to select **View Network Configuration**, then press **OK**, or if you prefer a printout, select **Print Network Configuration**, then press **OK**. If you selected Print Network Configuration, a Test Page prints with the IP Address and other network information.
 - d. If you selected View Network Configuration, use the down arrow to locate the IP Address, in the format xxx.xxx.xxx.xxx. (See [Viewing the network configuration, page 20.](#))
2. Open your preferred browser.
3. Type the printer's IP address in the browser address (URL) bar, then press **Enter**.

Using the Online Printer Management Tool to configure your printer's settings

With the Online Printer Management Tool open in your browser:

1. Select the **Settings** tab.
2. Click **Device**.
3. As needed, make changes to **General** or **Date & Time** settings, or **Reset** the printer setting to the factory defaults.

NOTE: Additional settings are available for Fax, Scan To, Copy, Print, and Security. These settings are discussed elsewhere in this guide.

This section explains how to configure your wireless network settings.

Connecting to a wireless network

To connect your printer to an 802.11b/g/n wireless (Wi-Fi) network, refer to the following information.

Before you connect

You need:

- a wireless router.
- to determine whether your wireless router supports Wi-Fi Protected Setup (WPS).

NOTE: If you have specific questions about your router, see your router manufacturer's documentation for more information.

For information, go to www.kodak.com/go/inkjetnetworking.

Connecting to a wireless network using the Wi-Fi Setup Wizard

You can use the Wi-Fi Setup Wizard on the printer to connect to your wireless network. Read the following procedures and use the one that is appropriate for your network setup.

Connecting to a non-WPS wireless router

To connect your printer to your wireless network, you need to know the network name, also called the Service Set Identifier (SSID). You can obtain your network name from the wireless router.

If your network has security enabled, you also need to know the Security String (passphrase or password).

Record your network information in the spaces below, using the correct uppercase and lowercase letters.

Network Name (SSID): _____

Security String (case-sensitive): _____

1. Press **Home**.
2. Press **▼** to select **Network Settings**, then press **OK**.
3. With **Wi-Fi Setup Wizard** selected, press **OK**.

NOTE: The Wi-Fi radio turns on when you select Wi-Fi Setup Wizard.

The Wi-Fi connectivity LED blinks as the printer searches for available wireless networks within range, then displays the list in order of signal strength. For example:

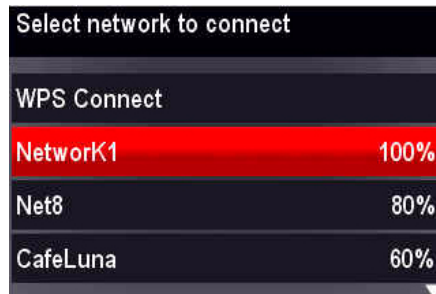

If there are more networks than can be shown on the LCD, a ▼ (page down) symbol appears in the bottom right of the display.

4. Press ▼ to select your network, then press **OK**.

If you don't see your network in the list, or if you want to change your network, select **Rescan for Wireless Networks**, then press **OK**.

NOTE: If the name of your network is not listed, make sure your wireless router is turned on and within range. If the name of your network is still not listed, go to www.kodak.com/go/inkjetnetworking for more information.

5. If your network requires a password, use the LCD keyboard to enter your Security String. The Security String is case-sensitive.



On the control panel, press ▲, ▼, ◀ or ▶ to select the letters and numbers, using the correct uppercase and lowercase letters. Press **OK** after each character. When you are finished, select **DONE**, then press **OK**

6. When the confirmation message appears, press **OK**.

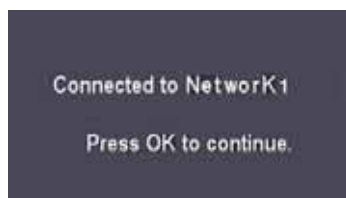

When the printer is successfully connected, the Wi-Fi connectivity LED will stop blinking and stay on steadily.

The printer with a wireless connection is listed as the name of the printer plus a number (for example, KodakESPOffice2150+0034).

NOTE: If you are unable to connect your printer, go to www.kodak.com/go/inkjetnetworking for more information.

7. If you haven't yet installed the KODAK All-in-One Printer Software:
 - a. Go to www.kodak.com/go/aiodownloads.
 - b. In the results list, click the link for KODAK All-in-One Printer Software for your computer's operating system.
 - c. Follow the on-screen instructions to install the software.

Connecting to a WPS wireless router

If your router supports Wi-Fi Protected Setup (WPS), you can use WPS Connect. WPS lets you configure your printer for a wireless network by pressing buttons or entering a PIN.

To connect to a network using WPS:

1. Press **Home**.
2. Press ▼ to select **Network Settings**, then press **OK**.
3. With **Wi-Fi Setup Wizard** selected, press **OK**.

NOTE: The Wi-Fi radio turns on automatically when you select Wi-Fi Setup Wizard.

4. With **WPS Connect** selected, press **OK**.



5. Select one of two methods of connecting:

IMPORTANT: Before you press **OK** on the printer, make sure you know where the router's push button is, or where to enter the generated PIN. If necessary, consult your Internet service provider or router device manufacturer's documentation for more information.

Push Button Configuration	Entering a PIN
<p>NOTE: You will have two minutes between selecting Push Button Configuration on the printer and pressing or selecting the WPS button, which may be a button on the router or a virtual button in the router's software.</p> <ol style="list-style-type: none"> With Push Button Configuration selected, press OK. Press or select the WPS button for your wireless router. 	<ol style="list-style-type: none"> Press ▼ to select Generate WPS PIN, then press OK. In your wireless router's software, locate the PIN screen. Enter the PIN you received on the LCD into the router's PIN screen.

6. When the confirmation message appears, press **OK**.

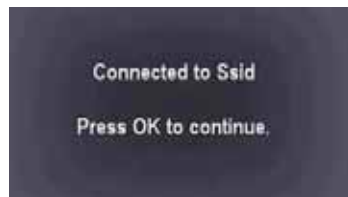

When the printer is successfully connected, the Wi-Fi connectivity LED stops blinking and stays on steadily.

NOTE: If you are unable to connect your printer, go to www.kodak.com/go/inkjetnetworking for more information.

The printer with a wireless connection is listed as the name of the printer plus a number (for example, KodakESPOffice2150+0034).

7. If you haven't yet installed the KODAK All-in-One Printer Software:
- Go to www.kodak.com/go/aiodownloads.
 - In the results list, click the link for KODAK All-in-One Printer Software for your computer's operating system.
 - Follow the on-screen instructions to install the software.

Setting up an IP address

IMPORTANT: *You should only need to set up an IP address for your printer if you are having a problem with connecting. Typically, it is not necessary to set up an IP address. This procedure is for advanced users who know how to obtain the IP address for the printer.*

All IP address entries have the following format: 000.000.000.000. Within each three-digit grouping, the number must be right-justified. If an address or subnet mask has only one or two characters between the periods, include one or two leading zeros in front of that number. For example:

The address as it may appear in your documentation	How to enter the address in the printer menu
149.89.138.149	149.089.138.149
149.2.40.149	149.002.040.149

For information about obtaining the printer IP address, go to www.kodak.com/go/inkjetnetworking.

To set up your IP address on the printer:

1. Press **Home**.
2. Press ▼ to select **Network Settings**, then press **OK**.
3. Press ▼ to select **Advanced IP Address Setup**, then press **OK**.
4. Press **OK** again to continue.
5. Select one of the following, then press **OK**:
 - **Dynamic (DHCP)**
 - **Manual (Static)**
6. If you selected **Manual (Static)**, you are prompted to enter an IP address, a Subnet Mask, a Gateway Address, and a DNS Server address. Press **OK** after each entry. Use the navigation buttons to enter each digit of the numbers. Consult your Internet service provider or network administrator for more information.

Viewing the network configuration

To view the network configuration and verify that you are connected to your wireless network:

1. Press **Home**.
2. Press ▼ to select **Network Settings**, then press **OK**.
3. Press ▼ to select **View Network Configuration**, then press **OK**.

The wireless network settings appear on the LCD, including:

- Printer Hostname
- Connection
- Speed
- IP Address
- IP Address Type
- Network Subnet
- Connected Network SSID
- Security
- Authentication
- Channel
- Region
- Radio (on/off)
- MAC Address

If the printer is connected to your network, you will see the network name and the word **CONNECTED**.

4. To scroll through the information, press ▼.
5. When you are done, press **OK**.

Printing the network configuration

To print the current network configuration:

1. Load plain paper into the printer. (See [Loading plain paper, page 26.](#))
2. Press **Home**.
3. Press ▼ to select **Network Settings**, then press **OK**.
4. Press ▼ to select **Print Network Configuration**, then press **OK**.

Changing the printer name

When the Online Printer Management Tool is displayed in the browser (see [Accessing the Online Printer Management Tool, page 14](#)):

1. Select the **Network** tab.
2. Click **General**, then **Friendly name**, if necessary.
3. Highlight the text in the **Friendly name** field and type the name you want, then click **Save**.

Installing your printer on additional computers on the network

To add your printer to another computer(s) on your network, install the KODAK All-in-One Printer Software on each computer.

1. Go to www.kodak.com/go/aiodownloads.
2. In the results list, click the link for KODAK All-in-One Printer Software for your computer's operating system.
3. Follow the on-screen instructions to install the software.

Connecting to another KODAK All-in-One Printer

If you are connecting to a newer model printer (for example, you have an ESP 7 printer and now you are adding an ESP Office 2150 printer), you must install the software for the newer model.

NOTE: When you install the new software, the printer driver for the ESP 7 printer will be uninstalled, and an upgraded driver for the ESP 7 printer will be installed in addition to the driver for the ESP Office 2150 printer.

On a computer with WINDOWS OS:

1. Select **Start > All Programs > Kodak > Kodak Printer Network Setup Utility**.
 - If your wireless all-in-one printer (example: KodakESPOffice2150+0034) **is not** listed:
 - a. Select **No, my printer is not listed**, then click **Next**.
 - b. From the drop-down list, select your printer.
 - c. Select **Network - Wireless/Wi-Fi**, then click **Next**.
When your printer is detected, driver installation begins.
 - If your wireless all-in-one printer (example: KodakESPOffice2150+0034) **is** listed:
 - a. Highlight the all-in-one printer that is connected to your network.
 - b. Select **Yes, my printer is listed**, then click **Next**.
When your printer is detected, driver installation begins.
2. When driver installation is complete, click **Done**.

On a computer with MAC OS:

1. Select **Apple > System Preferences**.
2. Under Hardware, select **Print & Fax**.
3. In the Print & Fax dialog box, click **+**.
4. Select your printer from the list, then click **Add**.

Adding a wireless network connection to a USB-connected computer

You can change the way you connect to your printer at any time.

Changing from USB to a wireless connection

To change the printer connection type from USB to a wireless (Wi-Fi) network:

If your printer is connected to a computer with WINDOWS OS:

1. Unplug the USB cable from your printer and computer.
2. On the printer control panel, press **Home**.
3. Press **▼** to select **Network Settings**, then press **OK**.
4. Press **▼** to select **View Network Configuration**, press **OK**, then confirm that the IP Address is not 0.0.0.0.
5. If you have not already done so, connect your printer to your wireless network. See [Connecting to a wireless network, page 15](#).
6. Select **Start > All Programs > Kodak > Kodak Printer Network Setup Utility**.
 - If your wireless all-in-one printer (example: KodakESPOffice2150+0034) **is not** listed:
 - a. Select **No, my printer is not listed**, then click **Next**.
 - b. Select your printer from the list.
 - c. Select **Network - Wireless/Wi-Fi**, then click **Next**.
When your printer is detected, driver installation begins.
 - If your wireless all-in-one printer (example: KodakESPOffice2150+0034) **is** listed:
 - a. Highlight the all-in-one printer that is connected to your network.
 - b. Select **Yes, my printer is listed**, then click **Next**.
When your printer is detected, driver installation begins.
7. When driver installation is complete, click **Done**.

The printer with a wireless connection is listed as the name of the printer plus a number (for example, KodakESPOffice2150+0034).

If your printer is connected to a computer with MAC OS:

1. Unplug the USB cable from your printer and computer.
2. On the printer control panel, press **Home**.
3. Press ▼ to select **Network Settings**, then press **OK**.
4. Press ▼ to select **View Network Configuration**, press **OK**, then confirm that the IP Address is not 0.0.0.0.
5. Select **Apple > System Preferences**.
6. Under Hardware, select **Print & Fax**.
7. In the Print & Fax dialog box, click **+**.
8. Select your printer from the list, then click **Add**.

The printer with a wireless connection is listed as the name of the printer plus a number (for example, KodakESPOffice2150+0034).

Handling Paper

For the best document printing results, use KODAK Document Papers or a paper with the COLORLOK Technology logo on the package. Use only paper that is designed for inkjet printers.

For the best photo printing results, use KODAK Photo Papers, which are optimized to work with KODAK All-in-One Printers, or photo papers designed for use on pigment-based inkjet printers.

When handling photo paper:

- Hold the paper by the edges; avoid placing your fingerprints on it.
- Do not touch the glossy side of photo paper.
- Store paper flat, away from direct sunlight and heat.

Paper types

You can use:

- Plain paper — 16 to 24 lb / 60 to 90 gsm
- Photo paper — up to 12 mils
- Card stock — 110 lb / 200 gsm, max
- Envelopes — most standard types
- Labels — all commercially available inkjet varieties on 8.5 x 11-in. or A4 sheets
- Transparencies — all commercially available inkjet varieties with a white strip on the long edge - 8.5 x 11-in. or A4 size
- Iron-on transfers — all commercially available inkjet varieties on 8.5 x 11-in. or A4 sheets

Paper sizes

The printer accepts the following paper sizes:

- 4 x 6 in. / 10 x 15 cm
- 4 x 7 in. / 10 x 18 cm
- 4 x 8 in. / 10 x 20 cm
- 4 x 12 in. / 10 x 31 cm
- 5 x 7 in. / 13 x 18 cm
- 7.3 x 8.5 in. / 18 x 22 cm
- 7 x 10 in. / 18 x 25 cm
- 7.3 x 10.5 in. / 18 x 27 cm
- 8 x 10 in. / 20 x 25 cm
- 8.5 x 11 in. / 22 x 28 cm
- 8.5 x 14 in. / 22 x 36 cm
- A4 (8.3 x 11.7 in. / 21 x 30 cm)
- A5 (5.8 x 8.3 in. / 15 x 21 cm)

- A6 (4.1 x 5.8 in. / 11 x 15 cm)
 - B5 (6.9 x 9.8 in. / 18 x 25 cm)
- NOTE: Do not load paper smaller than 4 x 6 in. / 10 x 15 cm.

Envelope sizes

The printer accepts the following envelope sizes:

- C5 (6.7 x 9 in. / 16 x 23 cm)
- C6 (4.5 x 6.4 in. / 11 x 16 cm)
- DL (4.3 x 8.7 in. / 11 x 22 cm)
- US #7 $\frac{3}{4}$ (3.9 x 7.5 in. / 10 x 19 cm)
- US #9 (3.9 x 8.9 in. / 10 x 23 cm)
- US #10 (4.1 x 9.5 in. / 11 x 24 cm)

IMPORTANT: Do not load envelopes with cutout or clear windows.

Loading paper

To load paper:

1. Open and lift the paper input tray.



2. Pull out the paper output tray and the extender until they are fully extended.



Loading plain paper

The capacity of the paper input tray is 150 sheets of plain paper.

1. Fan and stack the paper.

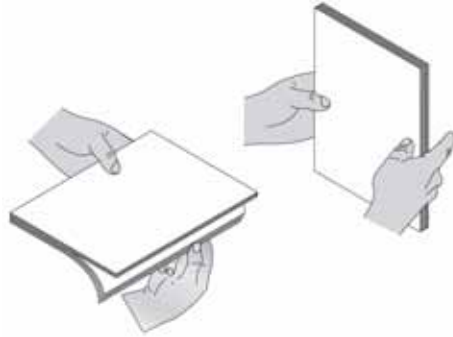

2. Make sure the left and right paper-edge guides are in the far left and far right positions, then insert the paper into the input tray.
3. Move the paper-edge guides until they touch the paper.



Loading photo paper

The capacity of the paper input tray is 20 sheets of photo paper.

To load photo paper:

1. Remove any paper from the input tray.
2. Insert the paper (short side first) into the center of the input tray with the **logo side toward the tray** and the **glossy side toward you**.

IMPORTANT: Always load the paper **short side first**. The printer automatically detects the orientation of the picture, whether it's portrait or landscape, and prints accordingly. If the photo paper is loaded in the wrong direction, the image will be cut off and the paper may jam. If the paper is loaded with the wrong side up, the image quality will be affected.

3. Move the paper-edge guides until they touch the paper.



Loading envelopes

The capacity of the paper input tray is 20 envelopes.

IMPORTANT: *Do not load envelopes with cutout or clear windows.*

To load envelopes:

1. Remove any paper from the input tray.
2. Insert the envelope(s) into the tray with the flap side toward the tray and the top of the envelope against the right side of the tray.
3. Move the paper-edge guides until they touch the envelope(s).

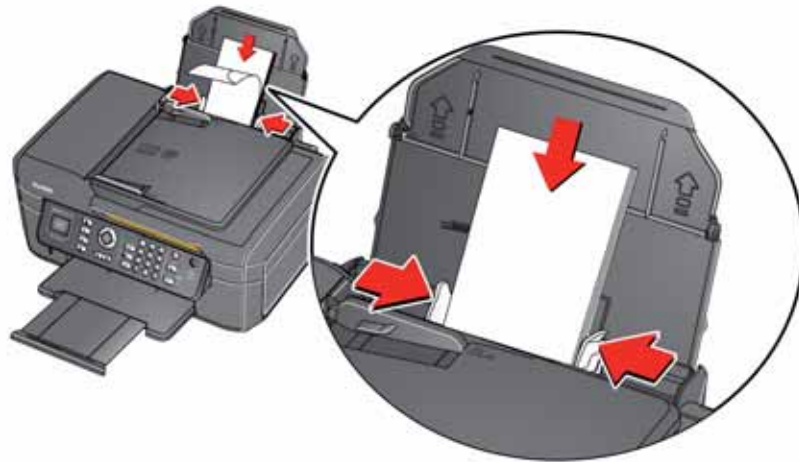

Loading originals

You can place originals for copying, scanning, or faxing on the scanner glass or in the ADF (automatic document feeder). The ADF automatically feeds the originals into the printer when you begin copying, scanning, or faxing.

NOTE: Keep the scanner glass clean. Any dirt or smudges on the glass will appear as marks on the copy. See [Cleaning the scanner glass and document backing, page 77](#).

Using the scanner glass

To place an original on the scanner glass:

1. Remove any originals from the automatic document feeder (ADF).
2. Lift the scanner lid, and place the document or picture face down in the right-front corner.



3. Close the scanner lid.

Using the Automatic Document Feeder (ADF)

You can load up to 25 originals (20 to 24 lb / 75 to 90 gsm plain paper) in the automatic document feeder (ADF).

The ADF accepts originals from 6.9 x 9.8 in. / 18 x 25 cm to 8.5 x 14 in. / 22 x 36 cm.

IMPORTANT: *Do not load photographs, originals on thick paper, or a document that is too small or too large to fit in the ADF.*

1. Remove any originals from the scanner glass.
2. Move the ADF paper-edge guides outward.



3. Fan and stack the originals, then insert them face up in the ADF, with the top of the pages in first.

IMPORTANT: *Remove all paper clips and staples from the originals.*



4. Move the ADF paper-edge guides until they touch the paper.

The ADF automatically feeds the originals into the printer when you begin copying, scanning, or faxing.

Print documents and lab-quality pictures on your printer.

Printing documents

To print a document from your computer:

1. Open the document.
2. Select **File > Print**.
3. In the Print dialog box, select your KODAK Printer.
4. Choose the pages to print, number of copies, etc, then click **OK** (on a computer with WINDOWS OS) or **Print** (on a computer with MAC OS).

Printing two-sided documents

You can print two-sided documents on any size paper that the printer accepts (see [Paper sizes, page 24](#)) by rotating the paper manually as described below.

IMPORTANT: *Two-sided printing can only be done on media that can absorb ink on both sides, such as plain paper or two-sided photo paper. Two-sided printing will not work on bar-coded photo paper (the bar code is on the back side).*

Printing two-sided documents from a computer with WINDOWS OS

To print two-sided documents from a computer with WINDOWS OS:

1. Load paper into the paper input tray.
2. Open the document you want to print, then select **File > Print**.
3. In the Print dialog box, make sure that your **ESP Office 2100 Series Printer** is selected (printers with a wireless connection have a 4-digit number added to the end of the name), then click **Properties**.
4. Select the **Layout** tab.
5. In the Two-sided printing field, select **Manual (Instructions provided)**, then click **OK** to close the Properties window.
6. Click **OK** to start the print job.
7. When a message appears on your computer or printer LCD telling you to do so, remove the printed pages from the output tray, and follow the instructions on the LCD.
8. Turn the printed pages over, and place them into the paper input tray (top edge down and printed side away from you).
9. Press **Start Black** or **Start Color** on the printer.

NOTE: It does not matter which **Start** button you press; the print job will continue printing in either color or black, depending on the document.

Printing two-sided documents from a computer with MAC OS

To print two-sided documents from a computer with MAC OS:

1. Load paper into the paper input tray.
2. Open the document you want to print, then select **File > Print**.
3. In the Print dialog box, make sure that your **ESP Office 2100 Series Printer** is selected (printers with a wireless connection have a 4-digit number added to the end of the name) is selected.
4. Continue with the next steps, depending on the version of Home Center Software you have.

v6.1	v6.2 or higher
<ol style="list-style-type: none"> 5. In the Copies & Pages list, select Paper Handling. 6. In the Pages to Print list, select Odd Only. 7. In the Page Order list, select Normal. 8. Click Print. 9. When the odd pages have finished printing, remove them from the output tray. 10. Turn the printed pages over, and place them into the paper input tray (top edge down and printed side away from you). 11. Select File > Print. 12. In the Copies & Pages list, select Paper Handling. 13. In the Pages to Print list, select Even Only. 14. In the Page Order list, select Normal. 15. Click Print. 	<ol style="list-style-type: none"> 5. In the Print dialog box, select the two-sided check box. 6. Click Print. 7. When the even pages have finished printing, follow the instructions on the printer LCD to reload the printed pages in the paper input tray. 8. Click Start on the printer control panel to print the odd numbered pages.

Printing forms

You can print the following preprogrammed forms:

- Graph Paper
- Wide Ruled
- Narrow Ruled
- Grocery List
- Reminder List
- Tic-tac-toe
- Sheet Music (Portrait)
- Sheet Music (Landscape)

To print a preprogrammed form from the printer control panel:

1. Press **Home**.
2. Press ▼ to select **Printable Forms**, then press **OK**.
3. Press ▼ to select a form.
4. Press ◀ or ▶ to select a quantity (up to 99), then press **OK**.
5. Press **Start Black** or **Start Color** on the printer.

NOTE: It does not matter which **Start** button you press; the form will print in either color or black, depending on the form.

Printing pictures

You can print pictures with your all-in-one printer from:

- A memory card inserted into a memory card slot
- A storage device (such as a flash drive) or digital camera connected to the front USB port with a USB cable (KODAK ESP Office 2170 printer only)
- An iPhone, iPod Touch, or iPad device. For information, go to www.kodak.com/go/picflick.

You can also print pictures using Home Center Software from your computer with WINDOWS OS. Home Center Software lets you edit and enhance your pictures quickly. Open Home Center Software, select **Print Pictures**, then follow the on-screen instructions.

On a computer with either MAC OS or WINDOWS OS, you can print pictures from any picture-editing or photo-management software.

Viewing pictures on a memory card or USB-connected device

NOTE: The option to use a USB-connected device, such as a digital camera or USB flash drive, is available only on the ESP Office 2170 printer.

When you insert a memory card into the memory card slot on your printer or a USB-connected device into the USB port, the pictures on the card or device appear on the LCD. Press ◀ or ▶ to scroll through the pictures.

If the printer is idle for more than two minutes, the LCD will revert to the status display. To view the pictures again, press any button, then press ◀ or ▶.

Finding pictures on a memory card or USB-connected device

Your printer can help you locate pictures on a memory card or USB-connected device by the date the picture was taken or last saved.

To locate pictures:

1. Insert the memory card into the memory card slot or the USB-connected device into the USB port (ESP Office 2170 printer only).
2. Press **Home**.
3. Press ▼ to select **View / Print Photos**, then press **OK**.
4. Press ▼ to select **Find Photos**, then press **OK**.
5. In the View by Date menu, press ▼ to select Year, Month, or Day; press ◀ or ▶ to select the specific year, month, or day.
The number of photos found for the date you specified appears under the menu name. To view pictures for the specified date, press **OK**.
6. Press **OK** to view the pictures.

Printing from a memory card or USB-connected device

NOTE: The option to print from a USB-connected device, such as a digital camera or USB flash drive, is available only with the ESP Office 2170 printer.

You can print pictures from a USB-connected device (ESP Office 2170 printer only), and from the following cards inserted into the memory card slot on your printer:

- SD Card
- SDHC Card
- MMC Card
- MEMORY STICK
- Variations of the memory cards listed above that require an adapter (for example, MEMORY STICK Duo, miniSD, and microSD)

IMPORTANT: *If you use a memory card with an adapter, make sure you insert and remove the adapter and the memory card as a unit; do not remove the memory card while leaving the adapter in the printer.*

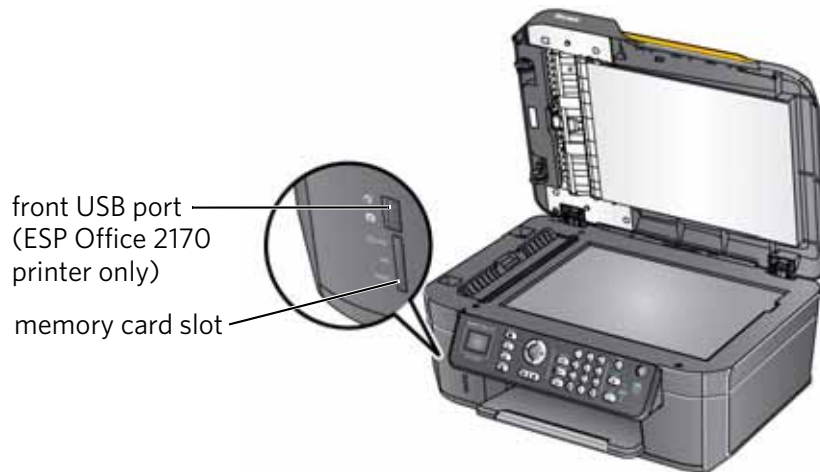

Using default settings to print a picture

Unless you change the default settings, the default for printing pictures is one 4 x 6 in. / 10 x 15 cm picture. (To change the default settings, see [Save as Defaults, page 38](#)).

To print a picture from a memory card or USB-connected device (ESP Office 2170 printer only) using the default settings:

1. Insert the memory card into the memory card slot, or connect a digital camera or USB flash drive to the front USB port.

IMPORTANT: *Do not use the memory card slot and the USB port at the same time.*

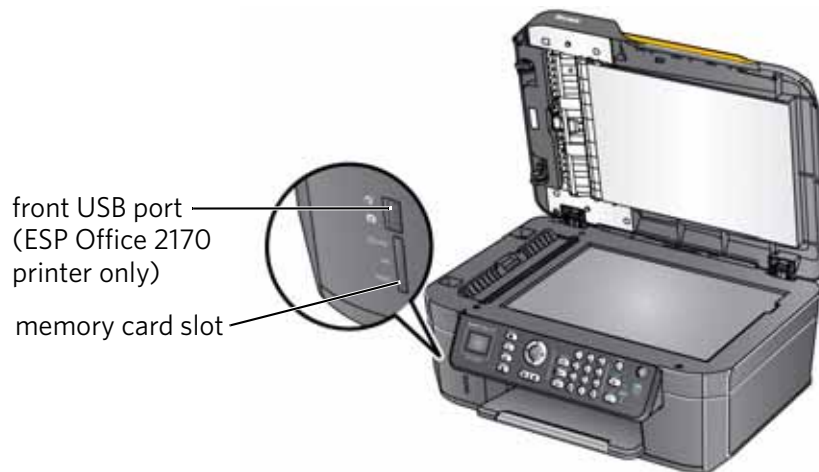

2. Press ◀ or ▶ to select the picture you want to print.
3. Press **Start Black** to print a black-and-white picture, or **Start Color** to print a color picture.

The printer prints a single 4 x 6 in. / 10 x 15 cm picture.

IMPORTANT: *To prevent loss of data from your memory card, do not remove it from the printer while printing.*

Changing the settings and printing pictures

You can change the print photos options for an individual picture or group of pictures, or you can change the settings and save them as the default.

To print a picture or pictures using settings other than the default settings:

1. Load photo paper with the glossy side toward you (see [Loading photo paper, page 27](#)), and move the paper-edge guides until they touch the paper.
2. Insert the memory card into the memory card slot, or connect a digital camera or USB flash drive to the front USB port (ESP Office 2170 printer only). A picture appears on the LCD.

IMPORTANT: Do not use the memory card slot and the USB port at the same time.

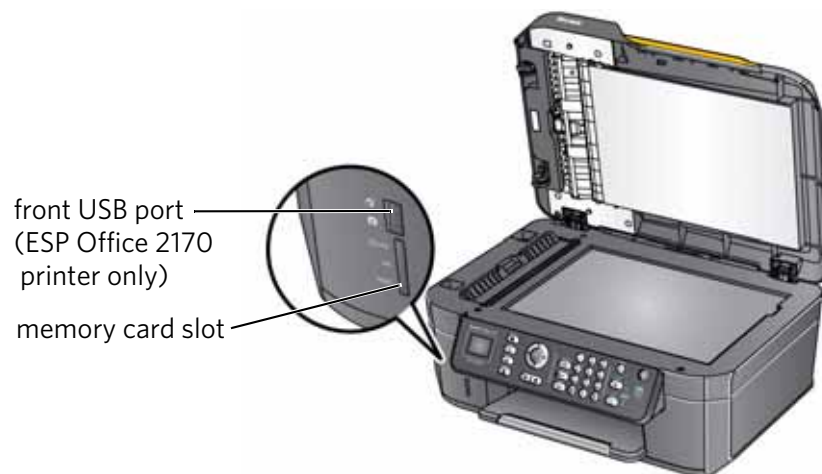

3. Press ◀ or ▶ to select the picture you want to print, then press **OK**.
4. Repeat step 3 for each picture you want to print.
5. Press **Back** for Remote Printing Settings.
6. Press ▼ to select an option (see table below), then press ◀ or ▶ to change the setting.

Print Photos Option	Settings	Description
View Photos	--	Scroll through the pictures on the memory card or, with ESP Office 2170 printers only, the USB flash drive or connected digital camera; press OK to select the picture for printing; press Back to display the Print Photos Options menu.

Print Photos Option	Settings	Description
Find Photos	--	Press OK , then select a year, month, and/or day to view photos by date that they were taken; press OK to view the photo(s); press Back to display the Print Photos Options menu.
Transfer All to PC	--	To transfer all the pictures on the memory card (or for ESP Office 2170 printers, on the USB-connected device) to your computer, press OK then press Start Black or Start Color . (It does not matter which Start button you press, but your printer and computer must be connected with a USB cable.)
Quantity	1 (default) to 99	The number of copies that print.
Print Size	2 x 3 3.5 x 5 4 x 6 (default) 4 x 7 4 x 8 5 x 7 4 x 12 8 x 10 8.5 x 11 or A4	If the selected print size is smaller than the paper in the paper input tray, the printer automatically arranges the pictures to best fit the paper size.
Plain Paper Quality	Normal (default)	Good quality output; prints faster than Best.
	Best	The highest quality, but the slowest print speed.
	Draft	The fastest print speed, but the lowest quality.
Photo Paper Quality	Auto. (default)	The printer detects when you load photo paper and sets Best quality automatically.
Scene Balance	On (default) Off	Adjusts the image brightness to correct for underexposure and reduces the variation in contrast in different areas of the picture.
Add Date to Prints	No (default) Yes	Prints the date of the picture(s) (the date the picture was taken or last edited) in a corner of the print.
Save as Defaults	No / Yes	To save the settings as the new default, press OK . With Yes selected, press OK .

NOTE: You can also adjust the print photo options using the Online Printer Management Tool. When viewing the tool in your browser (see [Accessing the Online Printer Management Tool, page 14](#)), select the **Settings** tab, then select **Copy & Print > Print Photo**.

- When you have finished changing settings, press **Start Black** to print a black-and-white picture, or **Start Color** to print a color picture.

IMPORTANT: *To prevent loss of data from your memory card, camera, or USB flash drive, do not remove it from the printer while printing.*

Printing panoramic pictures

To print a panoramic picture, load 4 x 12 in. / 10 x 31 cm paper, or US letter or A4 paper in the paper input tray.

- Insert the memory card into the memory card slot or a USB-connected device in the USB port (ESP Office 2170 printer only).

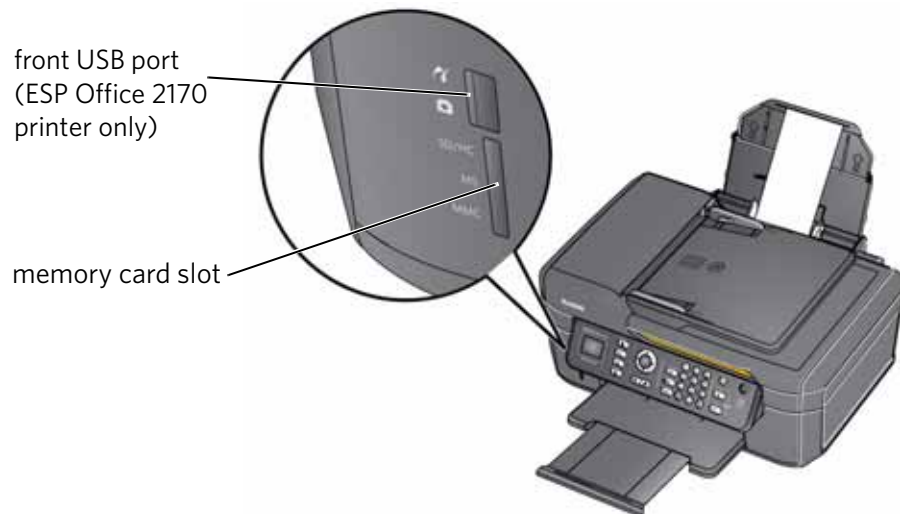

- Press ◀ or ▶ to select the panoramic picture you want to print, then press **OK**.
- Press **Back** for Remote Printing Settings.
- Press ▼ to select **Print Size**, then press ▶ to select **4 x 12**.
- Press **Start Black** to print a black-and-white picture, or **Start Color** to print a color picture.

IMPORTANT: *To prevent loss of data from your memory card, camera, or USB flash drive, do not remove it from the printer while printing.*

Printing tagged pictures

Some digital cameras let you tag (or “mark”) pictures on the memory card for printing. This creates a tag that is recognized by the printer. If you choose to print tagged pictures, they will print according to the default settings on your printer (unless otherwise specified by the tag from the camera).

NOTE: Refer to your camera user guide to determine whether your camera supports tagged (also “marked” or “DPOF”) functionality.

To print tagged pictures:

1. Insert the memory card into the memory card slot or a USB-connected device into the front USB port (ESP Office 2170 printers only).

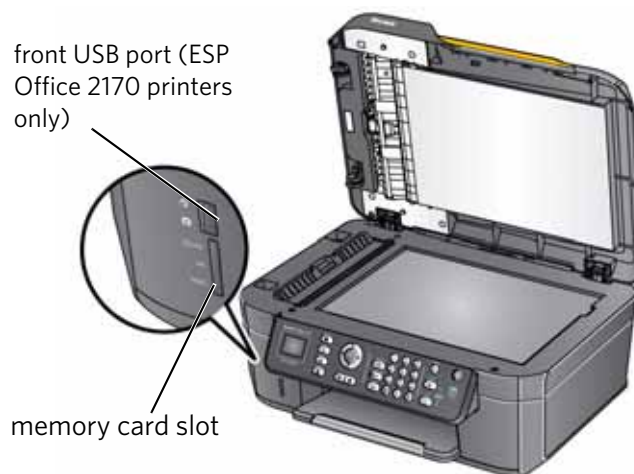

2. When the “Print tagged images?” message appears, press **Start Black** to print a black-and-white picture, or **Start Color** to print a color picture.

Printing from a wireless device

Wirelessly print pictures from an iPhone, iPod Touch, or iPad device* at the touch of a button. Download the KODAK Pic Flick App from the App Store, or go to www.kodak.com/go/picflick for more information.

* Compatible with iPhone, iPad and iPod Touch (2nd Generation or later) devices. Requires iOS 3.0 or later.

Transferring pictures to a computer

You can transfer your image files from a memory card, or for ESP Office 2170 printers, from a USB-connected device) in the printer to your computer. To transfer these files, the printer **must** be connected to your computer with a USB cable.

NOTE: If you have large video files or a large number of pictures (400 or more), we recommend that you transfer them using a memory card reader attached directly to your computer.

Transferring pictures to a computer with WINDOWS OS

1. Insert the memory card into the card slot or the USB-connected device into the USB port (ESP Office 2170 printers only).
2. Press **Back**.
3. Press ▼ to select **Transfer All to PC**, then press **OK**.
4. Press **Start Black** or **Start Color**.

NOTE: It does not matter which **Start** button you press.

5. If your computer is connected to your printer using both a wireless network and a USB cable, select the USB-connected printer (no number after the printer name).
6. Follow the on-screen instructions on your computer.

Transferring pictures to a computer with MAC OS

1. Insert the memory card into the card slot or the USB-connected device into the USB port (ESP Office 2170 printers only).
2. Press **Back**.
3. Press ▼ to select **Transfer All to PC**, then press **OK**.
4. Press **Start Black** or **Start Color**.

NOTE: It does not matter which **Start** button you press.

5. If your computer is connected to your printer using both a wireless network and a USB cable, select the USB-connected printer (no number after the printer name).
6. Use iPhoto or Image Capture on your computer to complete the transfer.

NOTE: You can adjust the Photo print settings using the Online Printer Management Tool. When viewing the tool in your browser (see [Accessing the Online Printer Management Tool, page 14](#)), select the **Settings** tab, then select **Copy & Print > Print Photo**.

You can copy documents and photographs with your all-in-one printer. The printer produces high-quality color or black-and-white copies on a variety of paper types (see [Paper types, page 24](#)).

Loading originals for copying

To copy documents (up to 25 pages) on plain paper, load the original(s) in the automatic document feeder (ADF).

To copy a photograph, documents on thick paper, or a document that is too small or too large to fit in the ADF, place the original on the scanner glass. (The ADF accepts originals from 6.9 x 9.8 in. / 18 x 25 cm to 8.5 x 14 in. / 22 x 36 cm.)

For more information on loading originals, see [Loading originals, page 29](#).

Copying a document

You can copy a document using the default settings, or you can adjust the quantity, size, quality, and brightness of your copies.

Using the default settings to copy a document

The default settings are either the factory default settings (see [Resetting factory defaults, page 84](#)), or defaults that you have set on the printer (see [Save as Defaults, page 43](#)).

To copy a document using the current default settings:

1. Place the original document in the ADF or on the scanner glass.
2. Press **Copy**.
3. Press **Start Black** to make a black-and-white copy, or press **Start Color** to make a color copy.

NOTE: If you load the original document in the ADF, the ADF automatically feeds the document into the printer when you begin copying.

Adjusting the settings and copying a document

To copy a document using settings other than the default settings:

1. Place the original document in the ADF or on the scanner glass.
2. Press **Copy**.

The Copy Document Options menu appears on the LCD.

3. Press ▼ to select an option, then press ◀ or ▶ to change the setting.

Copy Document Option	Settings	Description
Quantity	1 (default) to 99	The number of copies that print.
Copy Size	Same Size (default)	The copy is the same size as the original.
	Fit to Page	The printer detects the size of the original on the scanner glass and the size of the paper in the paper tray, and automatically reduces or enlarges the original so that the copy fits on the paper.
	20% to 500%	Reduces up to 20% or enlarges up to 500% of the original size.
Plain Paper Quality	Normal (default)	Good quality output; prints faster than Best.
	Best	The highest quality, but the slowest print speed.
	Draft	The fastest print speed, but the lowest quality.
Photo Paper Quality	Auto. (default)	The printer detects photo paper in the paper tray and sets Best quality automatically.
Brightness	Normal, -3 to +3 (Normal is default)	Lightens or darkens the copy. Normal is no change from the original; -3 is the darkest; +3 is the lightest.
Save as Defaults	No / Yes	To save the settings as the new default, press OK . With Yes selected, press OK .

4. Press **Start Black** to make a black-and-white copy, or press **Start Color** to make a color copy.

Changing the number of copies of a document

To change the number of copies:

1. Place the original document in the automatic document feeder (ADF) or on the scanner glass.
2. Press **Copy**.
The Copy Document Options menu appears on the LCD.
3. Make sure **Quantity** is selected.
4. Press ◀ or ▶ to select a number, or use the numeric keypad to enter the number of copies.
5. Press **Start Black** to make black-and-white copies, or press **Start Color** to make color copies.

Enlarging or reducing a document

To enlarge or reduce the size of the copy:

1. Place the original document in the automatic document feeder (ADF) or on the scanner glass.
2. Press **Copy**.
The Copy Document Options menu appears on the LCD.
3. Press ▼ to select **Copy Size**.
4. Press ◀ or ▶ to select an enlargement or reduction.
5. Press **Start Black** to make a black-and-white copy, or press **Start Color** to make a color copy.

Darkening or lightening a copy

To darken or lighten the copy:

1. Place the original document in the automatic document feeder (ADF) or on the scanner glass.
2. Press **Copy**.
The Copy Document Options menu appears on the LCD.
3. Press ▼ to select **Brightness**.
4. Press ◀ to select a number below zero for a darker copy, or press ▶ to select a number above zero for a lighter copy.
5. Press **Start Black** to make a black-and-white copy, or press **Start Color** to make a color copy.

Copying a photograph

You can copy a photograph using the default settings, or you can make adjustments to the quantity, size, quality, and brightness of your copies.

Using the default settings to copy a photograph

The default settings are either the factory default settings (see [Resetting factory defaults, page 84](#)), or defaults that you have set on the printer (see [Save as Defaults, page 46](#)).

To copy a photograph using the current default settings:

1. Place the original photograph face down on the scanner glass.

IMPORTANT: *Do not load photographs in the automatic document feeder (ADF).*

2. Press **Home**.
3. Press ▼ to select **Copy Photo**.
4. Press **Start Black** to make a black-and-white copy, or press **Start Color** to make a color copy.

Adjusting the settings and copying a photograph

To copy a photograph using settings other than the default settings:

1. Place the original photograph face down on the scanner glass.

IMPORTANT: *Do not load photographs in the automatic document feeder (ADF).*

2. Press **Home**.
3. Press ▼ to select **Copy Photo**, then press **OK**.
4. Press ▼ to select an option, then press ◀ or ▶ to change the setting.

Copy Photo Option	Settings	Description
Quantity	1 (default) to 99	The number of copies that print.
Copy Size	2 x 3 3.5 x 5 4 x 6 (default) 4 x 7 4 x 8 5 x 7 4 x 12 8 x 10 8.5 x 11 or A4	The printer enlarges or reduces the original to make it the copy size you select. If the selected copy size is smaller than the paper in the paper tray, the printer automatically arranges the pictures to best fit the paper size. Some cropping may occur if the image size and the selected print size are different.

Copy Photo Option	Settings	Description
Plain Paper Quality	Normal (default)	Good quality output; prints faster than Best.
	Best	The highest quality, but the slowest print speed.
	Draft	The fastest print speed, but the lowest quality.
Photo Paper Quality	Automatic (default)	The printer detects photo paper in the paper tray and sets Best quality automatically.
Brightness	Normal, -3 to +3 (Normal is default)	Lightens or darkens the copy. Normal is no change from the original; -3 is the darkest; +3 is the lightest.
Preview	No (default) / Yes	To see a preview of the photograph on the LCD, select Yes .
Save as Defaults	No / Yes	To save settings as the new default, press OK , select Yes , then press OK .

5. Press **Start Black** to make a black-and-white copy, or press **Start Color** to make a color copy.

Changing the number of copies of a photograph

To change the number of copies:

1. Place the original photograph face down on the scanner glass.
2. Press **Home**.
3. Press ▼ to select **Copy Photo**, then press **OK**.
4. Make sure **Quantity** is selected.
5. Press ◀ or ▶ to select a number, or use the numeric keypad to enter the number of copies.
6. Press **Start Black** to make black-and-white copies, or press **Start Color** to make color copies.

Enlarging or reducing a photograph

To enlarge or reduce the size of the copy:

1. Place the original photograph face down on the scanner glass.
2. Press **Home**.
3. Press ▼ to select **Copy Photo**, then press **OK**.
4. Press ▼ to select **Copy Size**.
5. Press ◀ or ▶ to select the copy size.
6. Press **Start Black** to make a black-and-white copy, or press **Start Color** to make a color copy.

Darkening or lightening a copy of a photograph

To darken or lighten the copy of the photograph:

1. Place the original photograph face down on the scanner glass.
2. Press **Home**.
3. Press ▼ to select **Copy Photo**, then press **OK**.
4. Press ▼ to select **Brightness**.
5. Press ◀ to select a number below zero for a darker copy, or press ▶ to select a number above zero for a lighter copy.
6. Press **Start Black** to make a black-and-white copy, or press **Start Color** to make a color copy.

Scanning

Scanning digitizes documents and pictures, and sends the digital files to your computer, memory card, email, network folder, or USB flash drive (ESP Office 2170 printer only).

To scan to a computer, the Home Center Software must be installed on that computer, unless you are using the Online Printer Management Tool. (See [Scanning from the Online Printer Management Tool, page 59.](#))

When you scan, the digital file can:

- Open in Home Center Software (when Home Center Software is loaded and the printer is connected to a computer with WINDOWS OS)
- Open in a third-party scanner software
- Be saved in a format and location that you determine (see [Changing the scan settings for scanning from the printer control panel, page 48](#))

Scanning from a software program on the computer (such as Home Center Software) gives you more options, but you can also scan from the printer control panel.

Before you begin scanning

If you are scanning to a computer, make sure that the printer is connected to a computer using a USB cable or wireless network (see [Networking Your Printer, page 15](#)).

If you want to scan to an email address or to a shared network folder, you need to:

- make sure the printer is connected to a computer using a wireless connection
- set up profiles using the Online Printer Management Tool (see [Adding a profile and address book for Scan To Email, page 51](#) and [Adding a profile for Scan To Network Folder, page 53](#))

Changing the scan settings for scanning from the printer control panel

Adjust the scan settings that the printer uses before you scan from the printer control panel.

NOTE: The settings in the Home Center Software only apply when Scanning to Computer, Scanning to Memory Card, or Scanning to Flash Drive (ESP Office 2170 printer only) from the printer control panel.

1. Open the Printer Tools window.
 - On a computer with WINDOWS OS, select **Start > All Programs > Kodak > Kodak AiO Printer Tools.**
 - On a computer with MAC OS, open Home Center Software, then select the **Tools** tab.
2. Under the Tools heading, select **Printer Scan Settings.**

3. Adjust settings for scanning documents and pictures:
- a. To select a program that scanned images or documents will appear in when you scan from the printer control panel:
 - (1) Select the **General** tab.
 - (2) Under the Program List heading, click ▼ next to the currently selected program.
 - (3) From the list, select the program in which you want the scanned files to open.
 - b. To adjust settings for scanning documents, select the **Document** tab, then select an option for each setting:

Setting	Options
Scan As	Black and white Color Grayscale
File format	.pdf .rtf (available only when connected to a computer with WINDOWS OS) .tif .jpg .bmp (available only when connected to a computer with MAC OS)
Resolution (dpi)	75 150 200 300
File Save	Prompt for File Name and Location Automatically Save - specify: <ul style="list-style-type: none"> ▪ Base name; by default, scanned files are names "scan1", "scan2", and so on. ▪ Location (folder) where the scanned files will be saved

- c. To adjust settings for scanning pictures, select the **Picture** tab, then select an option for each setting:

Setting	Options
Scan As	Color Black and white
File format	.jpg .bmp .tif
Resolution (dpi)	75 150 200 300 600
Quality	When connected to a computer with WINDOWS OS: <ul style="list-style-type: none"> ▪ Best for E-mail ▪ Normal ▪ High ▪ Maximum When connected to a computer with MAC OS, a slider bar with: <ul style="list-style-type: none"> ▪ Least ▪ Medium ▪ Best
Automatically Detect Pictures (when connected to a computer with WINDOWS OS) or Auto Crop (when connected to a computer with MAC OS)	When selected, multiple pictures placed on the scanner glass are saved as separate files.
File Save	Prompt for File Name and Location Automatically Save - specify: <ul style="list-style-type: none"> ▪ Base name; by default, scanned files are names "scan1", "scan2", and so on. ▪ Location (folder) where the scanned files will be saved

NOTE: If you scan from within Home Center Software, or scan to Home Center Software from the front panel, before you save a scanned file, you will be able to preview it in Home Center Software, crop and sharpen the image, and adjust color, if desired. On a computer with WINDOWS OS, see the Home Center Software Help (? icon) for instructions.

4. When you are finished making selections, click **OK** on the bottom right of the Printer Scan Settings window.
5. Close the Printer Tools window.

Adding a profile and address book for Scan To Email

You can send one or more scans directly to an email recipient from the printer, but first you need to set up a profile for yourself and define one or more email addresses.

1. Open the Online Printer Management Tool in a browser (see [Accessing the Online Printer Management Tool, page 14](#)).
2. Select the **Settings** tab, then click **Scan To Email > Email Profile**.
3. Click **Add New Outgoing Email Profile**.
4. In the **Profile Name** field, type a name that has meaning to you; for example, your initials and your email provider, such as AZ Hotmail or AZ Gmail. This name will appear on the control panel for you to select when initiating a scan to be sent through email.
5. For **From Email Address**, type your email address. Although the email will be sent from the printer, any replies will go to your Inbox.

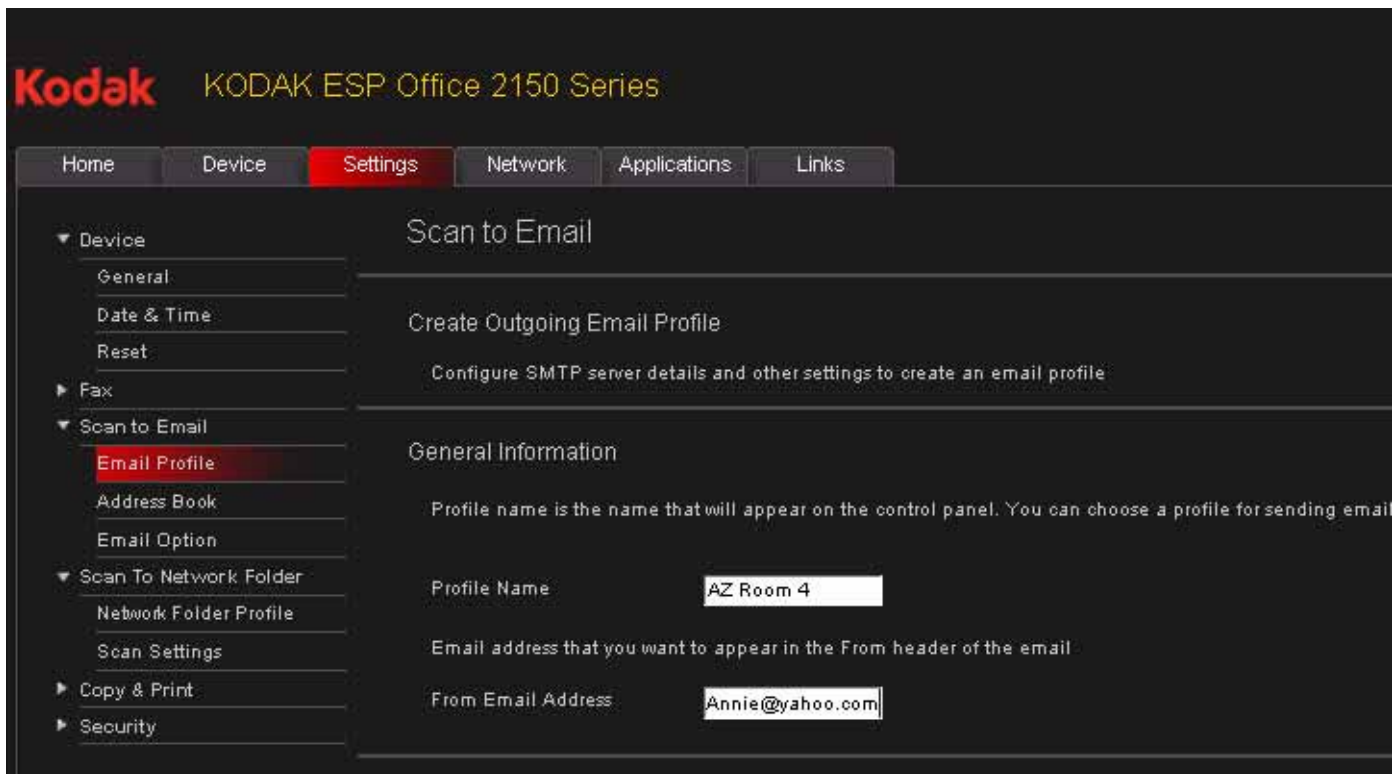

6. Enter your server information. This information can be obtained from the email account properties fields in your email client application (Outlook Express, Outlook, Eudora, etc) under the Outgoing mail server configuration section or directly from your ISP.
 - a. In the **SMTP Server** field, type the name or IP address of your server for sending emails.
 - b. In the **SMTP Port Number**, type the port number of your server for sending emails.
 - c. If your mail server (ISP) supports secure connection mode, select the **Always use secure connection** check box.
7. If your SMTP server requires authentication when you connect from your email client application:
 - a. Select the **The email server requires authentication for outgoing email** check box.
 - b. Type the **User ID** and **Password** for your email account.
8. If you want to control who is able to use your profile for sending a scan using your email account:
 - a. Select the **Enable Access Pin** check box.
 - b. Type a 4-digit numeric **PIN** (your choice). You will need to enter this PIN each time you access your profile when scanning to an email address.
9. Click **Test Profile** to have the printer confirm that it can access your account on the SMTP server.

10. Enter email addresses of people to whom you want to send scans by email.
 - a. Click the **Address Book** selection in the menu to the left.
 - b. For each person:
 - (1) Type the person's **Name**.
 - (2) Type the person's **Email Address**.
 - (3) Click **Add**.

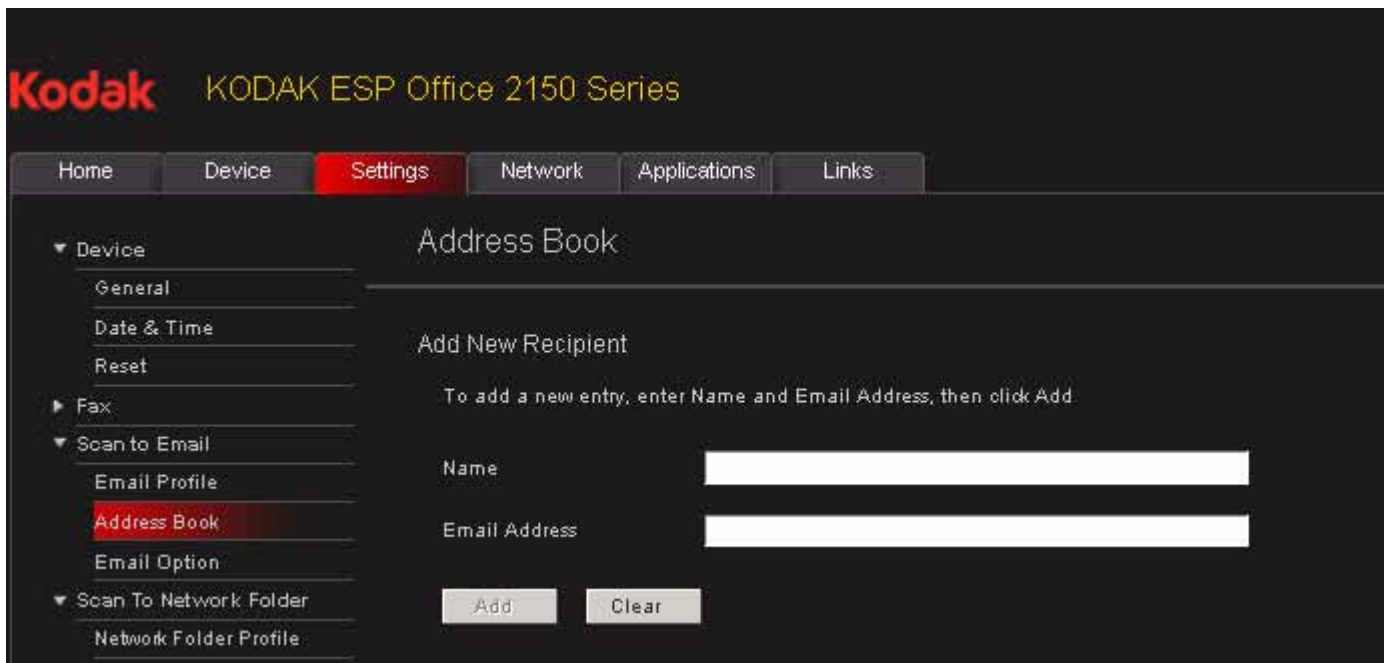

You are now ready to send a scan to an email address from the printer control panel. See [Scanning from the control panel, page 57](#)

Adding a profile for Scan To Network Folder

You can scan documents or photos directly to a file in a shared folder on your network. This saves time and allows you to keep a permanent record.

To add a network folder profile on your printer's control panel, you first need to identify or create a network shared folder on a computer connected to the same network as your printer. Note the network name of the folder, including the path information, and the name of the computer where it is located.

To learn more about sharing folders, see the information in the links below.

- For computers with WINDOWS XP OS, see www.microsoft.com/windowsxp/using/networking/maintain/share.mspx
- For computers with WINDOWS VISTA OS, see technet.microsoft.com/en-us/library/bb727037.aspx

- For computers with WINDOWS 7 OS, see windows.microsoft.com/en-US/windows7/File-sharing-essentials
 - For computers with MAC OS 10.4, see docs.info.apple.com/article.html?path=Mac/10.4/en/mh1161.html
 - For computers with MAC OS 10.5 or later, see support.apple.com/kb/ht1549
1. Open the Online Printer Management Tool in a browser (see [Accessing the Online Printer Management Tool, page 14](#)).
 2. Select the **Settings** tab, then click **Scan to Network Folder > Network Folder Profile**.
 3. Click **Add New Network Folder Profile**.



4. Type a **Profile Name** and a **Folder Path**.

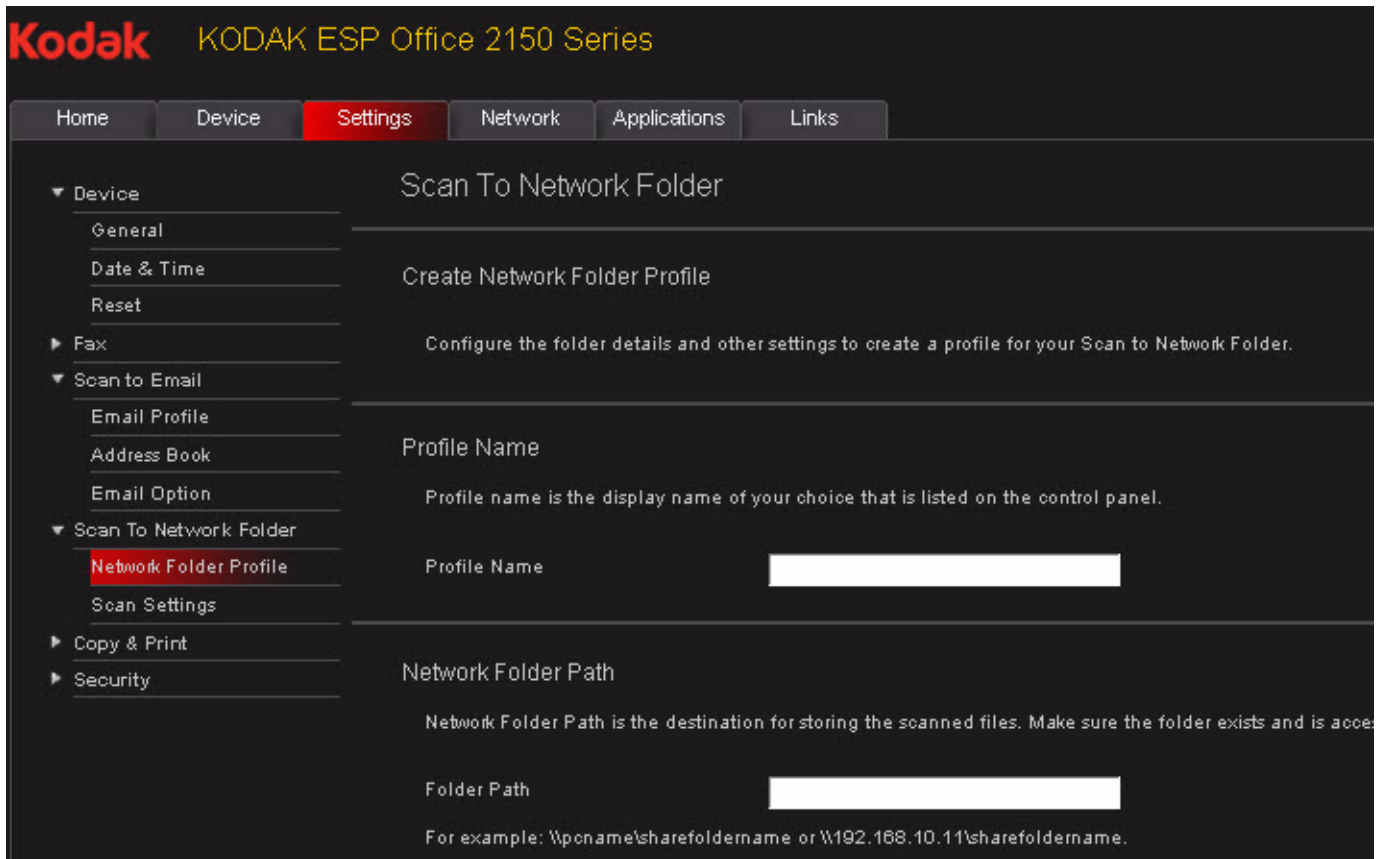

5. If the computer where the folder is located requires authentication to access its shared folders, type the network login **User Name** and **Password**.
6. If you want to control who is able to use your profile to scan documents to your network folder, select the **Enable Access PIN** check box and type a 4-digit numeric **PIN**.
7. Click **Test Profile** to have the printer confirm that it can access the network folder.

You are now ready to scan a document or photo to your network folder from the printer control panel. See [Scanning from the control panel, page 57](#)

Loading originals for scanning

To scan documents (up to 25 pages) on plain paper, load the original(s) in the automatic document feeder (ADF).

To scan a photograph, documents on thick paper, or a document that is too small or too large to fit in the ADF, place the original on the scanner glass. (The ADF accepts plain paper originals from 6.9 (18 cm) to 8.5 (22 cm) wide and 9.8 in. (25 cm) to 14 in. (36 cm) long)

For more information on loading originals, see [Loading originals, page 29](#).

Scanning from the computer

To scan a document or a picture:

1. Load the original.
2. Open Home Center Software.
 - On a computer with WINDOWS OS, double-click **Scan Documents and Pictures**, then follow the on-screen instructions.
 - On a computer with MAC OS and Home Center Software, select the **Tools** tab, click **Scan Application**, then follow the on-screen instructions.

NOTE: If you are not using Home Center Software, open a program that allows you to scan, then follow the instructions.

Scanning multiple pictures simultaneously

Using Home Center Software, you can scan multiple pictures simultaneously and save them as separate files.

When scanning multiple pictures, leave space between the pictures so that the printer can detect the separate pictures. Any pictures that overlap are interpreted as a single picture.

Scanning multiple pictures when connected to a computer with WINDOWS OS

To scan multiple pictures simultaneously, and save them as separate files:

1. Lift the scanner lid, and place the pictures face down on the glass, leaving space between the pictures.
2. Close the lid.
3. Open Home Center Software, then double-click **Scan Documents and Pictures**.
4. Make sure that **Picture** is selected and **Collage - Combine all pictures** is cleared, then follow the on-screen instructions.

NOTE: Click the Help icon for additional instructions.

Scanning multiple pictures when connected to a computer with MAC OS

To scan multiple pictures simultaneously, and save them as separate files:

1. Lift the scanner lid, and place the pictures face down on the glass, leaving space between the pictures.
2. Close the lid.
3. Open Home Center Software, then select your printer.
4. Select the **Tools** tab.
5. Click **Scan Application**.
6. Select **Color Picture** or **Black and White Picture**.
7. Select **Automatically detect multiple pictures**, if it is not selected.
8. Click **Preview** or **Scan All**, then follow the on-screen instructions.

NOTE: Click the Help icon for additional instructions.

Scanning from the control panel

To scan a document or picture(s) from the control panel:

1. Load the original.
2. Press **Scan**.

The Scan Menu appears on the LCD with the following options:

- Scan to Computer - used to scan to a file or Home Center Software on your computer; in Home Center, you can select from a list of applications that you can open directly with the scanned image
- Scan to Memory Card - used to scan to a memory card
- Scan to Flash Drive (ESP Office 2170 printer only) - used to scan to a USB flash drive
- Scan to Email - used to scan to an email address
- Scan to Network Folder - used to scan to a shared network folder

3. Press ▼ to select an option, then press ◀ or ▶ to change the setting.

NOTE: The Scan to email and Scan to network folder features in the Online Printer Management Tool have additional options that are not listed here.

Scan Option	Settings	Description
Scan To	USB Computer (default)	The scanned document or picture is sent to a file or folder, based on the settings defined in Changing the scan settings for scanning from the printer control panel, page 48 .
	Name of computer (only if a computer is connected by wireless network)	The scanned document or picture is sent to a file or folder, based on the settings defined in Changing the scan settings for scanning from the printer control panel, page 48 .
	Memory Card	The scanned file is sent to the memory card in one of the memory card slots.
	USB Flash Drive (ESP Office 2170 printer only)	The scanned file is sent to the flash drive attached to the front USB port.
	Email	The scanned file is sent to an email address that you select from the Email Profile you set up in the Online Printer Management Tool (see Adding a profile and address book for Scan To Email, page 51).
	Network Folder	The scanned file is sent to a shared folder that you designated in the Online Printer Management Tool (see Adding a profile for Scan To Network Folder, page 53).
Scan What	Document (default)	Sets the scan settings for scanning a document (see Changing the scan settings for scanning from the printer control panel, page 48).
	Photo	Sets the scan settings for scanning a photograph (see Changing the scan settings for scanning from the printer control panel, page 48).

Scan Option	Settings	Description
Destination	File (default)	Sends the scanned file in the format and to the location on your computer that you designate (see Changing the scan settings for scanning from the printer control panel, page 48).
	Application	Sends the scanned file to Home Center Software.
Save as Defaults	No / Yes	To save the settings as the new default, press OK . With Yes selected, press OK .

4. Press **Start Black** to make a black-and-white scan, or press **Start Color** to make a color scan.

The scanned file appears at the destination you specified.

Scanning from the Online Printer Management Tool

You can use an Internet browser to initiate a scan from within the Online Printer Management Tool on a computer that is connected to the same network as the printer. The computer does not need the All-in-One Printer Software (or drivers) installed.

1. When viewing the Online Printer Management Tool in a browser (see [Accessing the Online Printer Management Tool, page 14](#)), select the **Applications** tab, then click **Applications > Webscan**.
2. Select the type of scan you want, and place the original on the scanner glass.
3. Click **Preview** to see what will be scanned.
 - If needed, click **Clear** to reposition the image.
4. When you are satisfied with the image, click **Scan** to capture the image. It will display in a new browser window.
5. In the new browser window, select **File > Save As** to save the image as a JPEG file on your computer.

Your printer can send and receive faxes in either black-and-white or color.

Before you begin faxing

Before you can send or receive faxes, you must connect your printer and set up the fax options on the printer.

Connecting the printer for faxing

Selecting the country/region

For the fax to work properly, the country or region selected on the printer must match your location. This setting determines how your faxes are sent and received.

To set the correct country or region:

1. Press **Home**.
2. Press ▼ to select **Printer Settings**, then press **OK**.
3. Press ▼ to select **Country/Region**, then press **OK**.
4. Press ▼ to select your country or region, then press **OK**.

Determining your telephone system type

The instructions for setting up your printer for faxing differ depending on the type of telephone service you have. Determine the type of telephone service you have, and connect your printer accordingly.

IMPORTANT: *Use the phone cord that was provided with the printer. If you use any other phone cord, you may not be able to send or receive faxes successfully.*

- **Standard telephone service** — telephone service that uses dedicated telephone wiring to transmit only phone signals
- **Cable telephone service** — telephone service that is delivered by a cable television service
- **Digital Subscriber Line (DSL)** — telephone service that uses the wires of a local telephone network to transmit digital data over cables
- **Internet telephone service** (Voice-Over-Internet-Protocol or VOIP) — telephone service delivered by an Internet provider

Connecting the printer to a Standard or Cable telephone service

If you have Standard or Cable telephone service, connect one end of the phone cord that came with the printer into the LINE IN port on the back of the printer and the other end into the wall phone jack.

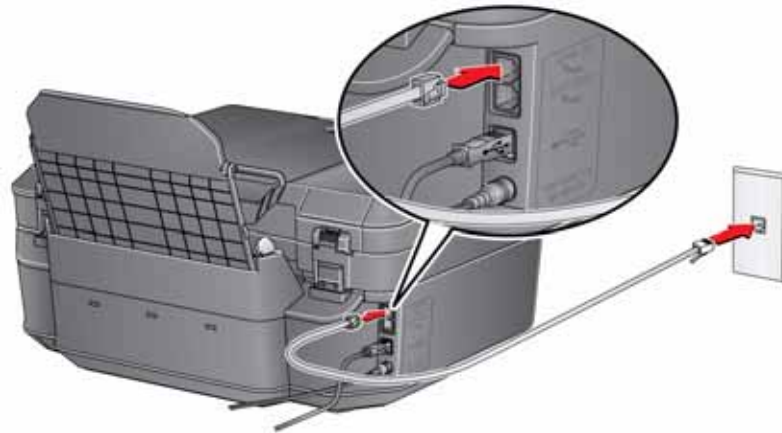

Connecting the printer to a Digital Subscriber Line (DSL)

If you have DSL telephone service, connect one end of the phone cord that came with the printer into the LINE IN port on the back of the printer and the other end into the DSL filter (available from your DSL provider), which is connected to the wall phone jack.

NOTE: You must use a DSL filter to transmit fax signals properly to your printer.

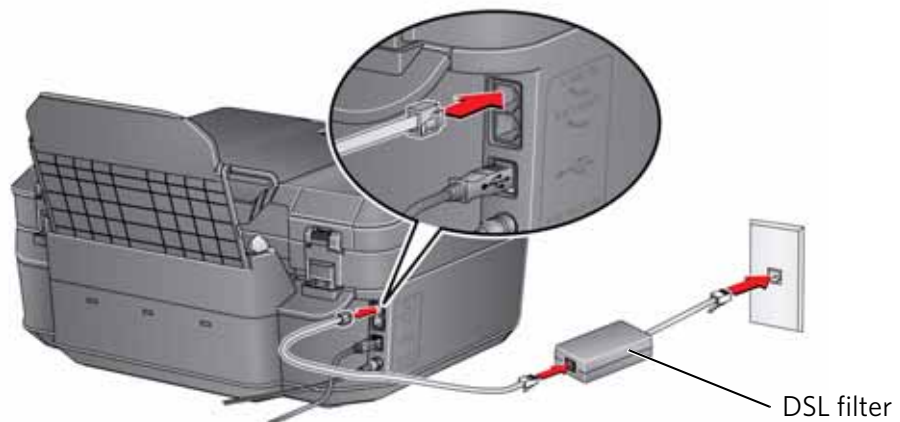

Connecting to Internet telephone service (Voice-Over-Internet Protocol or VOIP)

If you have Internet telephone service, you should already have a cable modem/router connected to the cable outlet with a coaxial cable. You will also need an Analog Telephone Adapter (ATA) to connect your printer for faxing.

NOTE: Sometimes the cable modem/router has a built-in ATA. Contact your cable telephone service provider for more information.

1. Connect an RJ-45 (also called CAT 5) cable from the cable modem/router to the WAN port on the Analog Telephone Adapter (ATA).
2. Connect one end of the phone cord that came with the printer (RJ-11 telephone cord) to one of the phone input ports on the ATA and the other end to the LINE IN port on the back of your printer.

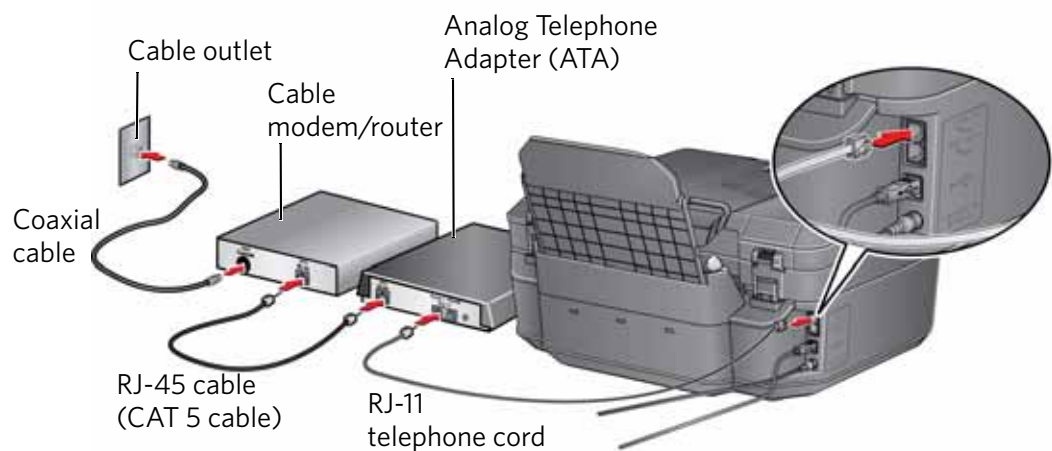

Determining whether your phone line is dedicated or shared

To connect your printer for faxing correctly, you need to determine whether your phone line is shared or dedicated

- A **dedicated phone line** is one that has only this printer and no other devices connected to it. If you have a dedicated line, connect your printer as described for your type of phone service (see [Connecting the printer to a Standard or Cable telephone service, page 61](#), [Connecting the printer to a Digital Subscriber Line \(DSL\), page 61](#), or [Connecting to Internet telephone service \(Voice-Over-Internet Protocol or VOIP\), page 62](#)).
- A **shared phone line** is one that has several devices connected to it, such as a phone and/or answering machine as well as the printer. If you have a shared line, connect your printer in one of the following ways, based on the devices you have connected to the same phone line.

If you share the line with an answering machine or telephone:

1. Connect one end of the phone cord that came with the printer into the LINE IN port on the back of the printer.
2. Connect the other end of the phone cord into a wall phone jack, DSL filter, or ATA, depending on the type of telephone service you use.
3. Connect one end of the phone cord for your answering machine into the LINE EX port on the back of the printer.
4. Connect the other end of the phone cord into the answering machine or telephone.

NOTE: If you have an answering machine, set the number of rings to answer on the printer to a *higher number* than the rings to answer for the answering machine (see [Rings to Answer, page 65](#)).

Configuration for connecting an answering machine with a standard telephone service

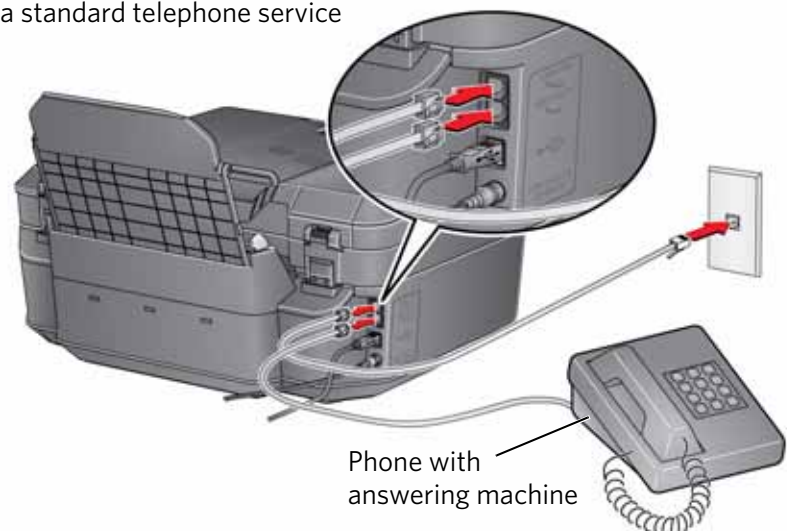

If you have an answering service:

If you have an answering service that uses a computerized system for recording messages remotely for the same phone line that you use for your all-in-one printer, then you can set up a distinctive ring to receive faxes automatically (see [Distinctive Ring, page 66](#)).

If you do not set up a distinctive ring, you can still receive faxes manually (see [Receiving a fax manually, page 74](#)).

Entering fax sender information

Fax sender information is the name, fax, and phone number that appear in the header of any fax that you send from your all-in-one printer. Typically this is your name or your business name, your fax number, and your phone number.

NOTE: If you do not enter fax sender information, the header on faxes that you send will be blank.

To enter fax sender information:

1. Press **Home**.
2. Press ▼ to select **Fax Settings**, then press **OK**.
3. With **Fax Sender Information** highlighted, press **OK**.
4. Use the numeric keypad on the control panel to enter:
 - your name or business name
 - your fax number
 - your phone number

See [Using the numeric keypad on the control panel to enter text and/or numbers, page 70](#)

5. When you are finished entering information in a field, press ▼. to move to the next field.
6. Press **OK** to save the information.

Setting fax options

Before sending or receiving faxes, set up the fax options.

To set up fax options from the control panel:

1. Press **Home**.
2. Press ▼ to select **Fax Settings**, then press **OK**.
3. Press ▼ or ▲ to select an option, then press ◀ or ▶ to change the setting.

Fax Option	Settings	Description
Fax Sender Information	--	This information appears on the faxes you send. Press OK , then enter the fax sender name (your name), your fax number, and your phone number (see Using the numeric keypad on the control panel to enter text and/or numbers, page 70); press OK to save.
Rings to Answer	1 to 6 (default is 4)	The number of times that your phone will ring before the printer picks up the call. If you use a dedicated phone line for your printer, set the Rings to Answer to any setting. If the printer shares the phone line with an answering machine, set the Rings to Answer to a higher number (5 or 6) than the rings to answer for the answering machine (typically 4 rings). This allows the answering machine to pick up phone calls. The printer will monitor the line after the answering machine picks up, and, if set to Auto Answer, will detect an incoming fax and receive it.
Redial if No Answer	Yes (default) / No	If the number you call is busy, the printer will redial the number once automatically.
Busy Redial Attempts	0 to 12 (default is 5)	The number of times that the fax will attempt to redial a busy number.

Fax Option	Settings	Description
Disable Call Waiting	No (default) / Yes	<p>If you have call-waiting service on your phone line, you can disable it so that an incoming call does not interrupt your fax transmission.</p> <p>Select Yes to disable call waiting, then enter the call waiting disable code (below).</p>
Call Waiting Disable Code	*70 (default)	<p>The printer automatically dials the call waiting disable code before dialing the number to which you are sending a fax. This code disables call waiting for the duration of the fax, preventing incoming calls from interrupting your fax transmission.</p> <p>The usual code to disable call waiting is the default *70. If the call waiting disable code is different in your area, press OK, then press ◀ to erase the current code. Use the keypad to enter the correct code, then press OK.</p> <p>NOTE: You must enable call waiting manually after your fax transmission.</p>
Distinctive Ring	Any ring (default) / Single Ring / Double Ring / Triple Ring	<p>This service, available from most phone companies, adds multiple phone numbers to one phone line. Each phone number then has a distinctive ring pattern (single, double, or triple ring) to let you know which number is ringing.</p> <p>Select the ring pattern assigned to the phone number for the printer so the printer can receive faxes automatically.</p>
Fax Speed	Fast - 33.6K (default) Medium - 14.4K Slow - 9.6K	Use this setting to reduce the fax transmission speed of your printer if you have difficulty with faxing at higher speeds.
Fax Speaker	On (default) / Off	The fax speaker allows you to hear the dial tone and initial fax tones when sending faxes.
Print Fax Confirmation Page	Never (default) / Always / After Failure Only	The Fax Confirmation Page contains the time and date, the number you called, the number you called from, and whether the transmission was successful.

Fax Option	Settings	Description
Print Fax Settings	--	To print the current fax settings, press OK . Load letter or A4 paper, then press Start Black or Start Color .
Print Fax Cover Page	--	The Fax Cover Page shows the date and headings for To and From information for your fax. Use this cover page, if needed, when sending your fax. To print a Fax Cover Page, press OK . Load letter or A4 paper, then press Start Black or Start Color . (The Fax Cover Page is black and white.)
Print Fax Activity Log	--	The Fax Activity Log contains information (date, time, duration, to/from, number of pages, and more) about the last 30 faxes sent and/or received. To print a Fax Activity Log, press OK . Load letter or A4 paper, then press Start Black or Start Color .
Dialing Mode	Tone (default) / Pulse	Determines how the printer dials a fax number. Tone dialing (the more common method) uses tones to dial a phone number. It is faster and more reliable than pulse dialing, which uses a series of pulses to dial a phone number. Traditionally, pulse dialing was used by rotary phones; tone dialing is used by touch-tone phones.
Error Correction	On (default) / Off	Error correction is applied only when sending black-and-white faxes. It reduces the loss of data, which can occur on poor phone lines. Error correction increases the send time on poor phone lines, but the transmission is much more reliable. (Error correction does not apply to faxes being received.)

To adjust fax settings from the Online Printer Management Tool:

1. Open the Online Printer Management Tool in a browser (see [Accessing the Online Printer Management Tool, page 14](#)).
2. Select the **Settings** tab, then click **Fax > Settings**.

3. Change the **Sender Information** and/or fax **Settings** as needed.
4. Click **Save** to update the settings on the printer.

Setting the answer mode (auto answer or manual)

The default setting is for Auto Answer to be on. When Auto Answer is on, the printer picks up all incoming faxes automatically. The green Auto Answer LED is lit when Auto Answer is on.

To answer calls manually, turn off Auto Answer by pressing the **Auto Answer** button so that the green LED is off. (See [Receiving a fax manually, page 74.](#))

Working with the phonebook

You can enter up to 60 fax numbers in the phonebook.

You can create and manage the phonebook from the printer LCD, or if connected to a computer with WINDOWS OS, you can use Home Center Software.

You can also use the Online Printer Management Tool to edit the Fax Phone Book. See [Using the Online Printer Management Tool to edit the Fax Phone Book, page 70](#)

Using symbols in phonebook entries

The following symbols are used in phonebook entries:

Symbol	Description	Response by fax
0 - 9	numbers	Dials number
*	star	Used for special features (for example, *70 is used to deactivate call waiting)
,	comma	Causes a 2-second delay before dialing the remaining numbers
#	pound	Used for special features (for example, # at the end of a number signifies the completion of the number sequence)

Adding a new phonebook entry

To add a new phonebook entry:

1. Press **Phonebook**.
2. Make sure **Edit Phonebook** is selected, then press **OK**.
3. Make sure **Add New Entry** is selected, then press **OK**.
4. Make sure **Number** is selected, then press **OK**.
5. Use the numeric keypad on the control panel to enter a fax number, then press **OK**.
6. With **Name** selected, press **OK**.
7. Enter a name using the numeric keypad (see [Using the numeric keypad on the control panel to enter text and/or numbers, page 70](#)).
8. When you are finished entering a name, press **OK**.
9. Optional: Assign a Quick Dial number.
Set up your ten most frequently used fax numbers as Quick Dial numbers. You will be able to dial them quickly, and they will be displayed at the top of your phonebook.
 - a. Press ▼ to select **Quick Dial**, then press **OK**.
 - b. Using the numeric keypad on the control panel, enter a number from 0 to 9, then press **OK**.
10. Press ▼ to select **DONE**, then press **OK**.

Editing a phonebook entry

To edit a phonebook entry:

1. Press **Phonebook**.
2. Make sure **Edit Phonebook** is selected, then press **OK**.
3. Press ▼ to select **Edit Entry**, then press **OK**.
4. Press ▼ to select the entry you want to edit, then press **OK**.
5. Press ▼ to select the field you want to edit, then press **OK**.
6. Use the or the numeric keypad (see [Using the numeric keypad on the control panel to enter text and/or numbers, page 70](#)) to make your change(s).
7. Press ▼ to select **DONE**, then press **OK**.

Deleting a phonebook entry

To delete a phonebook entry:

1. Press **Phonebook**.
2. Make sure **Edit Phonebook** is selected, then press **OK**.
3. Press ▼ to select **Delete Entry**, then press **OK**.
4. Press ▼ to select the entry you want to delete, then press **OK**.

NOTE: If you do not want to delete the entry, press **Cancel**.

5. To delete the entry, press **OK**.

The entry is deleted from the phonebook.

6. Repeat steps 4 - 5 to delete more entries; when you are finished, press **Back** or **Cancel**.

Using the numeric keypad on the control panel to enter text and/or numbers

The number keys on the numeric keypad represent a number and several characters. For example, the number **2** key also represents the letters A, B, C and a, b, and c. You must press the **2** key multiple times to enter a corresponding letter. For example, to enter the letter "B" as the first letter of a name, press the **2** key two times; to enter the small letter "b" at the beginning of a name, press the **2** key five times. If the small letter "b" is not at the beginning of a name or word, press the **2** key two times.

If you need to use the same key for more than one letter in a row (for example, to type "Cab"), you need to pause between letters. To type "Cab", press the **2** key three times to enter "C", then pause 3 to 4 seconds; press the **2** key once to enter "a", then pause for 3 to 4 seconds; and press the **2** key two times to enter "b". You do not need to pause if the next letter is on a different key.

Note that the Symbols (*) key and the Space (#) key also cycle through several different symbols when you press the key multiple times.

To make a correction to your entry, press ◀ (navigation button) on the control panel to erase the rightmost character.

Using the Online Printer Management Tool to edit the Fax Phone Book

1. Open the Online Printer Management Tool in a browser (see [Accessing the Online Printer Management Tool, page 14](#)).
2. Select the **Settings** tab, then click **Fax > Phonebook**.
3. For each entry, type a **Name** and **Fax** number. Select a **Quick Dial** as needed.
4. Click **Add** to update the printer.
5. Select the check box for an existing entry in the **Phone Book**.
6. Edit or delete the entry as needed.
7. Click **Save** to update the printer.

Preparing a fax for transmission

Before you send a fax, prepare a cover page (if needed), load the original(s), and change the resolution and brightness (if needed).

Printing a fax cover page

If you need a fax cover page, you can print one with your printer, then manually complete the information (person to whom you are sending, fax number, your name, etc).

To print a fax cover page:

1. Press **Home**.
2. Press ▼ to select **Fax Settings**, then press **OK**.
3. Press ▼ to select **Print Fax Cover page**, then press **OK**.
4. Load letter or A4 paper, then press **Start Black** or **Start Color** to begin printing.

NOTE: It does not matter which Start button you press; the fax cover prints in black only.

Loading originals

To fax documents (up to 25 pages) that are on plain paper, load the original(s) in the automatic document feeder (ADF).

To fax a photograph, originals on thick paper, or a document that is too small or too large to fit in the ADF, place the original on the scanner glass. (The ADF accepts originals from 6.9 x 9.8 in. / 18 x 25 cm to 8.5 x 14 in. / 22 x 36 cm.)

NOTE: You can fax only one page at a time from the scanner glass.

For more information on loading originals, see [Loading originals, page 29](#).

Changing resolution and brightness

Before sending your fax, change the resolution and brightness settings, as needed, based on your original.

To modify settings before sending your fax:

1. Press **Fax**.
2. With **Fax Options** selected, press **OK**.
3. Press ▼ to select **Resolution**.

The resolution setting determines the amount of detail that is transmitted.

Select:

- **Standard** (default) for most documents
- **Fine** for documents with fine print
- **Photo** for photographs

4. Press ▼ to select **Brightness**.

Adjust the brightness setting according to how light or dark your original is.

Select:

- **Normal** (default) for most documents
- **+1 to +3** to lighten dark originals
- **-1 to -3** to darken light originals

NOTE: If you do not want to save these settings, send your fax. The settings will apply only to the current transmission. If you want to save these settings as defaults:

- a. Press ▼ to select **Save as Defaults**, then press **OK**.
- b. Select **Yes**, then press **OK**.

Sending a fax

You can send your fax in several ways. You can use:

- the phonebook
- Quick Dial
- the numeric keypad
- the Redial button

Using the phonebook to send a fax

To send a fax to a number in the phonebook:

1. Press **Phonebook**.
2. Press ▼ to select the desired number.
3. Press **Start Black** to send a black-and-white fax or **Start Color** to send a color fax.

Using Quick Dial to send a fax

To send a fax using Quick Dial:

1. Press **Phonebook**.
2. Press the number on the keypad that corresponds to the desired Quick Dial entry.
3. Press **Start Black** to send a black-and-white fax or **Start Color** to send a color fax.

Using the numeric keypad to send a fax

To send a fax from the numeric keypad:

1. Press **Fax**.
2. Enter a fax number using the numeric keypad.
3. Press **Start Black** to send a black-and-white fax or **Start Color** to send a color fax.

Using the Redial button to send a fax

To send a fax to one of the last numbers dialed:

1. Press **Redial**.
2. Press ▼ to select an entry.
3. Press **Start Black** to send a black-and-white fax or **Start Color** to send a color fax.

If there is no number to redial, the phonebook opens.

Receiving a fax

You can set up your printer to receive faxes automatically or manually. Even if your printer is set up to receive faxes automatically, you can still receive them manually at any time.

Receiving a fax automatically

To receive faxes automatically:

1. Load letter (8.5 x 11 in. / 22 x 28 cm) or A4 (8.3 x 11.7 in. / 21 x 30 cm) plain paper into the paper tray (see [Loading plain paper, page 26](#)).
2. Make sure the Auto Answer LED is on. (If not, press **Auto Answer** to turn it on.)

The printer will receive all incoming faxes automatically.

IMPORTANT: *Whenever there is an incoming fax, the printer LCD shows the message, "Incoming Call. Press START to Answer." If the Auto Answer LED is on, you do not need to press START to receive the fax. The printer will automatically receive the fax after the number of rings that you selected for the fax settings (see [Rings to Answer, page 65](#)). However, you may choose to receive the fax sooner by pressing either START button. (Whether the fax is color or black is determined by the sender.)*

Receiving a fax manually

If Auto Answer is turned off for your printer, you can receive incoming faxes manually.

NOTE: You can receive any incoming fax manually, even if Auto Answer is turned on.

To receive a fax manually:

- When you hear the phone ring, press **Start Black** or **Start Color**.

NOTE: Pressing either Start button triggers the printer to receive the fax. It does not matter which Start button you press; whether a fax is color or black and white is determined by the sender.

If your printer is connected to the same phone line as another telephone and you are using tone dialing (see [Dialing Mode, page 67](#)), you may receive an incoming fax manually from another phone. When you hear the distinctive ring of your fax line or know that the incoming call is a fax:

- Pick up any phone and dial **234** (the remote access code).

Printing fax reports

You can set up the printer to print certain reports automatically. You can also print reports manually at any time. Fax Settings report

Fax settings report

To print the current fax settings:

1. Press **Home**.
2. Press ▼ to select **Fax Settings**, then press **OK**.
3. Press ▼ to select **Print Fax Settings**, then press **OK**.
4. Load letter or A4 paper, then press **Start Black** or **Start Color**

Fax confirmation page

The Fax Confirmation Page contains the time and date of transmission, the number that you called and the number you called from, and whether the transmission was successful. To print the Fax confirmation page, you must select the option to print before you transmit the fax. The default setting is to never print the fax confirmation page.

To print the fax confirmation page for future faxes:

1. Press **Home**.
2. Press ▼ to select **Fax Settings**, then press **OK**.
3. Press ▼ to select **Print Fax Conf. Page**.
4. Press ◀ or ▶ to select **Always** (to print a confirmation page after sending every fax) or **After Fail Only** to print only if the fax transmission fails.
5. Press **OK**.

NOTE: The name and fax number of receivers will not appear on your confirmation page if the receivers have not set up that information on their fax machines.

Fax activity log

The Fax Activity Log provides detailed information approximately the last 30 faxes sent or received. The log contains the information such as date, time, duration of transmission, to/from, and number of pages.

To print a Fax Activity Log:

1. Press **Home**.
2. Press ▼ to select **Fax Settings**, then press **OK**.
3. Press ▼ to select **Print Fax Activity Log**, then press **OK**.
4. Load US Letter (8.5 x 11 in.) or A4 paper, then press **Start Black** or **Start Color**.

NOTE: The name and fax number of receivers will not appear on your fax activity log if the receivers have not set up that information on their fax machines.

Canceling a fax

You can cancel a fax that you are sending or receiving at any time.

To cancel sending or receiving a fax:

- Press **Cancel**.

Maintaining Your Printer

Your printer requires little maintenance. However, Kodak recommends cleaning the scanner glass and lid regularly to remove dust and fingerprints, which affect the quality and accuracy of scanning.

Except while cleaning the printer, keep the printer plugged into an AC power outlet. If you use a power strip, don't turn off the power strip. (The printer does not need to be turned on but should be plugged in.)

For optimal performance, keep the printer connected to a computer that is powered on, or keep the printer powered on and connected to the Internet through a wireless network.

Keep the printhead and ink cartridges in the printer at all times to help prevent damage to the printhead.

For recycling and/or disposal information, contact your local authorities. In the US, go to the Electronics Industry Alliance at www.eia.org or go to www.kodak.com/go/recycle.

General care and cleaning

CAUTION:

Always disconnect the power to the printer before cleaning it. Do not use harsh or abrasive cleaners on any part of the printer.

- To clean the printer, wipe the outside with a clean, dry cloth.
- Keep the surrounding area vacuumed and litter-free.
- To clean the printer, wipe the outside with a clean, dry cloth.
- Protect the printer from tobacco smoke, dust, and liquid spills.
- Do not place objects on the printer.
- Keep the input tray free of dust, dirt, and other foreign objects.
- Keep the printer supplies away from direct sunlight and out of high-temperature environments.
- Do not allow chemicals to come into contact with the printer.

Cleaning the scanner glass and document backing

The scanner glass can get smudged and minor debris can accumulate on the white document backing under the scanner lid. Periodically clean the scanner glass and document backing.



CAUTION:

Do not use harsh or abrasive cleaners on any part of the printer.

Do not spray liquid directly on the glass.

Do not use paper-based wipes on the document backing as they can scratch it.

To clean the scanner glass and document backing under the scanner lid:

1. Turn off the printer and unplug it from the power outlet.
2. Lift the scanner lid.



3. Wipe the glass with a soft cloth or sponge, slightly moistened with a nonabrasive glass cleaner.



4. Dry the glass with a lint-free cloth.
5. Gently clean the document backing with a soft cloth or sponge, slightly moistened with mild soap and warm water.



6. Dry the document backing with a chamois or lint-free cloth.
- NOTE: If the document backing needs further cleaning, use isopropyl (rubbing) alcohol on a soft cloth, then wipe thoroughly with a cloth moistened with water to remove any residual alcohol.
7. When you finish cleaning, plug in the printer.

Replacing ink cartridges

Your printer uses both black and color ink cartridges. You can check the approximate ink levels on the LCD (see [Checking ink levels, page 84](#)) or in Home Center Software. When an ink cartridge is out of ink, the printer LCD displays a message stating that the black or color ink cartridge needs replacing.

IMPORTANT: *Do not use non-Kodak brand or refilled ink cartridges.*

To replace an ink cartridge:

1. Make sure your printer is on.
2. Lift the printer access door, and wait for the carriage to move to a position where you can access it.



The ink cartridges are located in the printhead.

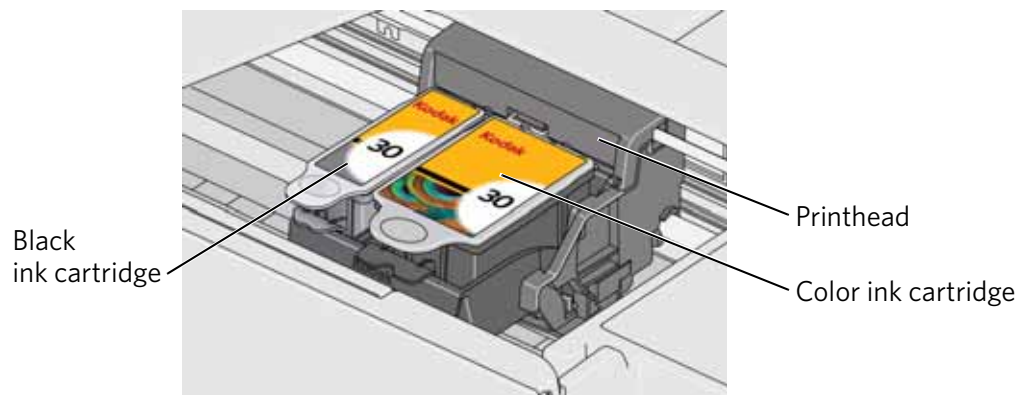

3. Pinch the tab on the ink cartridge.

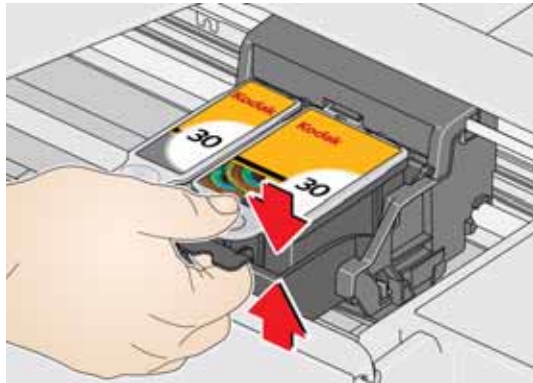

4. Lift the ink cartridge out of the printhead.

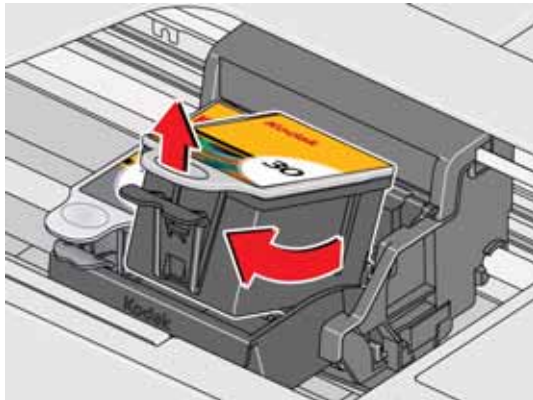

5. Remove the new ink cartridge from its bag.



IMPORTANT: *To prevent the printhead from drying out, insert the ink cartridge into the printhead immediately.*

6. Remove the protective cap from the cartridge.

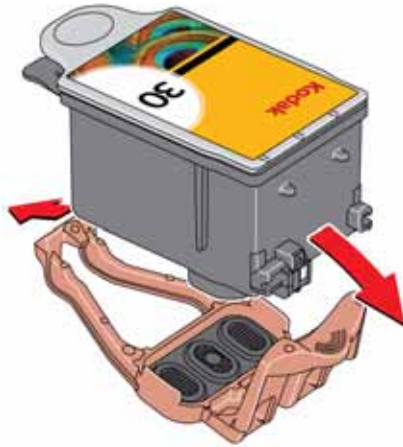

7. Insert the ink cartridge into the printhead.

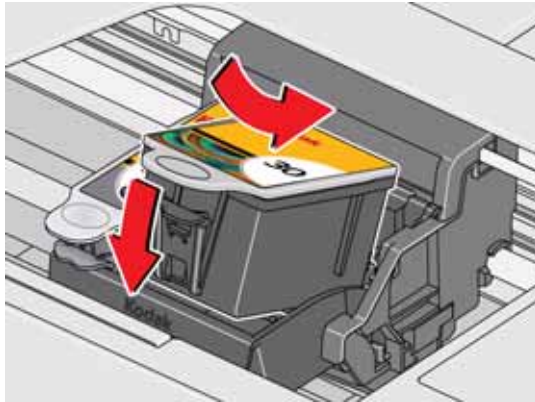

8. Press down on the ink cartridge tab until you hear a click.

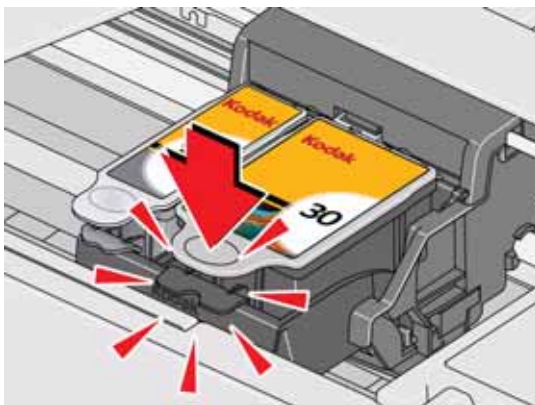

9. Close the printer access door.

Updating the software and printer firmware

Using the latest software and firmware helps ensure optimal performance of your printer.

NOTE: Firmware is the software that runs on your printer.

Although there is a background check for software and firmware updates, you may update manually using the following procedure.

Updating manually if your printer is connected to a computer with WINDOWS OS

To update the software:

1. Make sure that your computer is connected to the Internet.
2. Select **Start > All Programs > Kodak > Kodak AiO Printer Tools**.
3. Under Printer Resources, click **Check for Software Updates** to check whether software updates are available.
4. If there are updates, click **Next** and follow the on-screen instructions.

To update the firmware:

1. Make sure that your computer is connected to the Internet.
2. Connect the printer to the computer with a USB cable or wirelessly (if not currently connected).
3. Select **Start > All Programs > Kodak > Kodak AiO Printer Tools**.
4. Make sure that **KodakESP2150+xxxx - Connected** (or a similar name with **Connected**) appears in the lower left corner of the Printer Tools window.

NOTE: If **KodakESP2150+xxxx - Connected** does not appear in the lower left corner, click **Select**, then click **Refresh List** and choose your printer from the list; click **Install KODAK Printer** and follow the on-screen instructions.

5. Under Printer Resources, click **Check for Printer (Firmware) Updates**.
6. If there are updates, click **Next** and follow the on-screen instructions.

IMPORTANT: *Do not turn off or unplug your printer or your computer during the update. Doing so may cause the printer to become inoperable. If the printer is connected wirelessly, make sure you have a stable connection when you perform the update.*

Updating manually if your printer is connected to a computer with MAC OS

To update the software:

1. Make sure that your computer is connected to the Internet.
2. Open Home Center Software.
3. Select the **Tools** tab.
4. Click **Check for Software Updates**.
5. If there are software updates, follow the on-screen instructions for updating your software.

To update the firmware:

1. Make sure that your computer is connected to the Internet.
2. Connect the printer to the computer with a USB cable or wirelessly (if not currently connected).
3. Open Home Center Software.
4. Select the **Tools** tab.
5. Click **Check for Printer (Firmware) Updates**.
6. If there are updates, follow the on-screen instructions.

IMPORTANT: *Do not turn off or unplug your printer or your computer during the update. Doing so may cause the printer to become inoperable.*

Monitoring and adjusting printer performance

From the control panel, you can perform tasks to help keep the printer functioning well.

Checking ink levels

To check the ink levels:

1. Press **Home**.
2. Press ▼ to select **Maintenance**, then press **OK**.
3. With **Check Ink Levels** selected, press **OK**.

The LCD shows approximate levels of ink in the cartridges so you know when it's time to order replacement cartridges.

NOTE: You can order ink cartridges online. Open Home Center Software and select **Order Supplies**.

Resetting factory defaults

To reset defaults to the factory default settings:

1. Press **Home**.
2. Press ▼ to select **Printer Settings**, then press **OK**.
3. Press ▼ to select **Reset All Settings**, then press **OK**.
4. When you see the message, "This will reset printer settings to factory defaults," press **OK**.

NOTE: Resetting factory defaults does not change the date and time, language, country/region, or network settings.

Replacing the printhead

IMPORTANT: Replacing the printhead is not a regular maintenance procedure. Replace the printhead only if you receive a new printhead from Kodak.

To replace the printhead:

1. Make sure your printer is on.
2. Lift the printer access door, and wait for the carriage to move to the access position.



3. Remove both ink cartridges and set them aside.

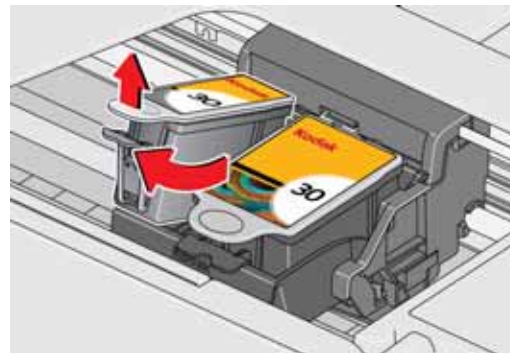
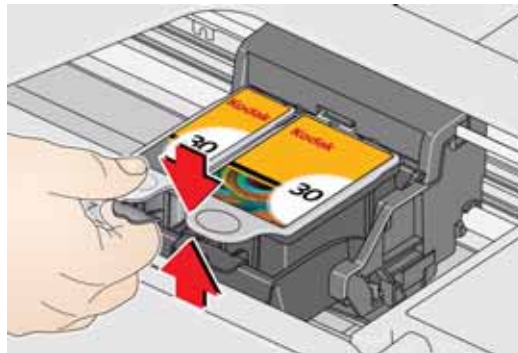

4. Unlatch the used printhead by lifting the button in the center of the carriage.

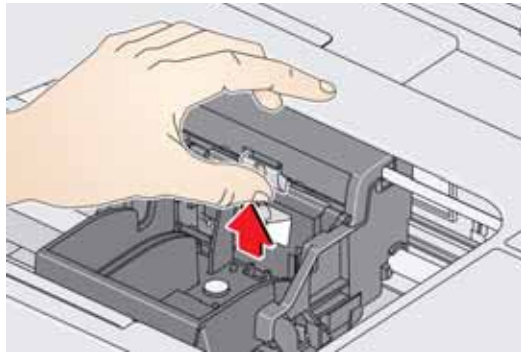

5. Lift the used printhead out of the carriage.

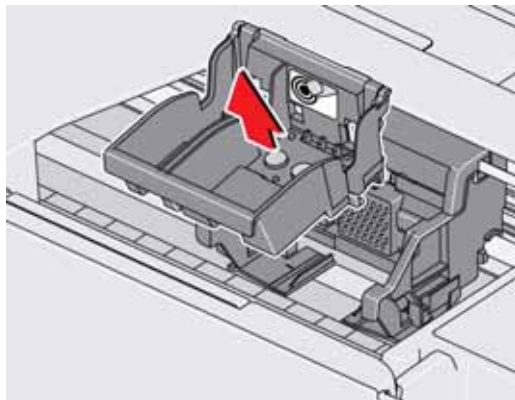

6. Remove the new printhead from its bag.



⚠ CAUTION:
Do not touch the copper contacts on the printhead, as doing so may damage the printhead.

7. Remove the plastic protective cap.

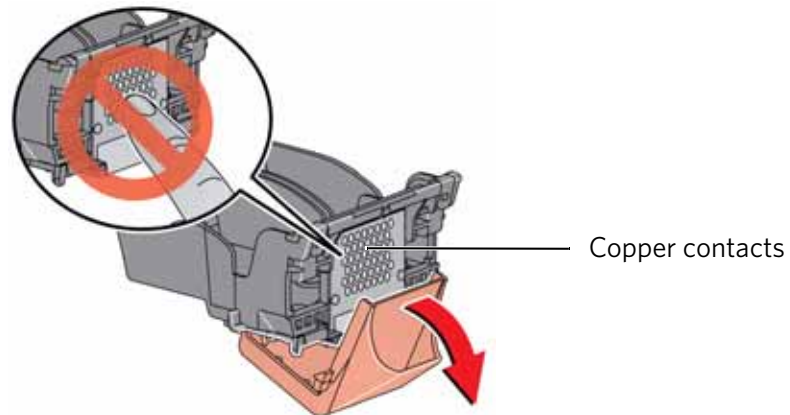

IMPORTANT: *Be careful not to scratch or touch the copper contacts while inserting the printhead.*

8. Place the new printhead into the carriage.

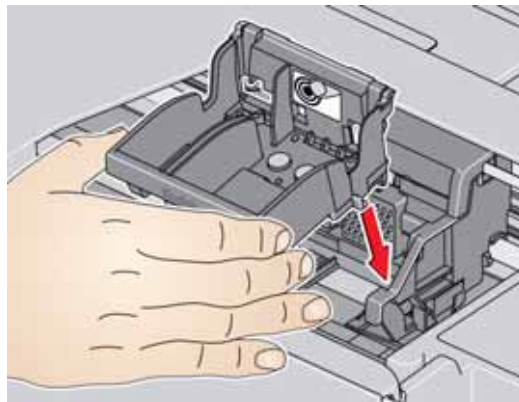

9. Push firmly against the target label of the printhead until you hear a loud snap.

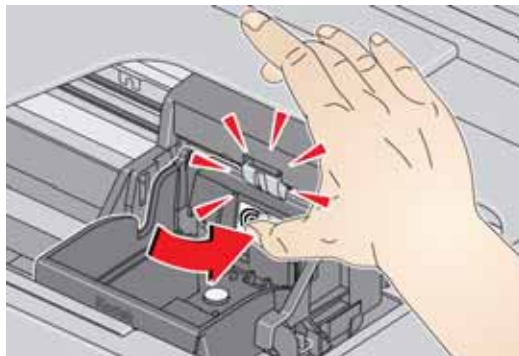

10. Insert the black ink cartridge into the printhead.

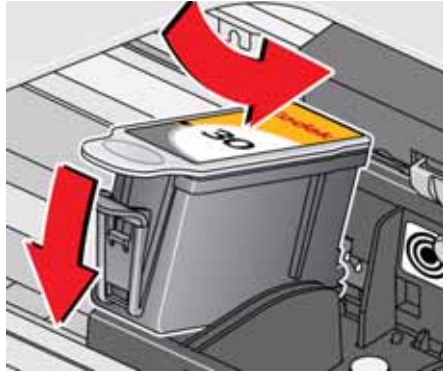

11. Press down on the ink cartridge until you hear it click into position.

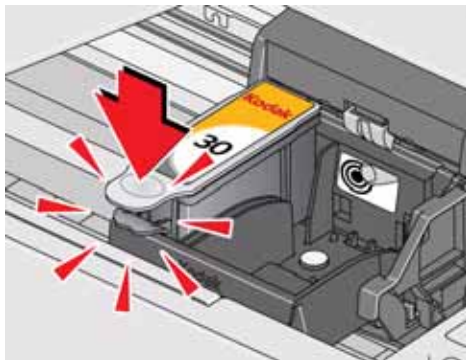

12. Repeat steps 10 - 11 for the color ink cartridge.

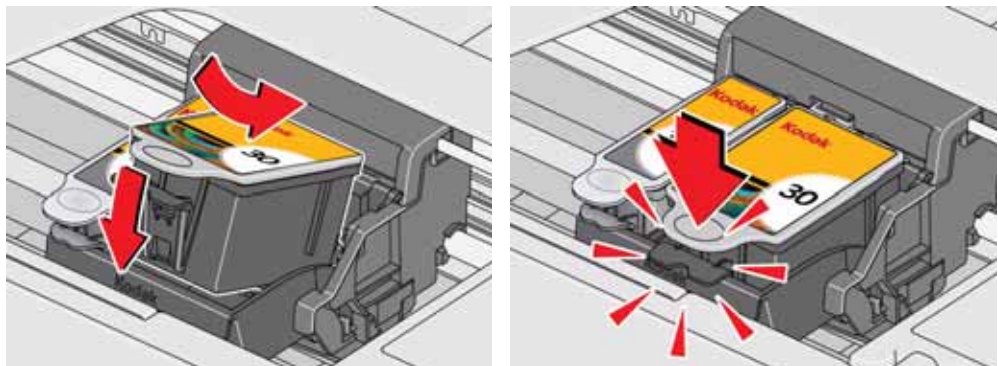

13. Close the printer access door.

The printer detects the new printhead. Follow the instructions on the LCD to calibrate your printer.

Basic troubleshooting

Some problems can be resolved quickly by power cycling the printer: Turn off your printer. Wait five seconds. Turn on the printer.

Use the following information to help troubleshoot problems with your printer.

Problem	Possible Solutions
Printer does not power on	<ul style="list-style-type: none"> ▪ Make sure you are using the power cord that came with your printer. ▪ Make sure that the power cord is connected to the AC adapter and is plugged into an outlet or power strip, and that the LED on the AC adapter is lit. ▪ Make sure that the power cord is securely connected to the power cord port in the back of the printer.
Printer not detected	<ul style="list-style-type: none"> ▪ Make sure that your printer is plugged in and turned on. ▪ If you are using a USB cable, make sure that: <ul style="list-style-type: none"> - it is a USB 2.0 high-speed cable. - it is connected to both your printer and your computer. - you restart the computer if the USB cable was disconnected from the printer then reconnected, or if power to the printer was interrupted. ▪ If you are using a wireless connection, make sure: <ul style="list-style-type: none"> - the Wi-Fi connectivity LED is glowing steadily. - the printer is connected to your wireless network. To check: <ol style="list-style-type: none"> a. On the printer, press Home. b. Press ▼ to select Network Settings, then press OK. c. Press ▼ to select View Network Configuration, then press OK. Make sure that the Active Connection Type is WiFi, and that the IP Address is not zeros. <ul style="list-style-type: none"> - your router is transmitting data. - the firewall (excluding WINDOWS Firewall) is allowing the services needed for your printer. <p>For additional information, go to www.kodak.com/go/inkjetnetworking.</p>
Wireless connectivity	For wireless connectivity issues, go to www.kodak.com/go/inkjetnetworking .
Carriage jam	<ul style="list-style-type: none"> ▪ Open the printer access door and clear any obstructions. ▪ Check that the printhead and ink cartridges are installed correctly. (The printhead and ink cartridges are installed correctly when you hear them click into place.)
Ink cartridge errors	<ul style="list-style-type: none"> ▪ Check that KODAK Ink Cartridge(s) are installed. Do not use non-Kodak brand or refilled ink cartridges. ▪ Remove, then install the cartridges again. Make sure the cartridges click into place.

Problem	Possible Solutions
Too much paper curl after printing	<ul style="list-style-type: none"> ▪ If you are printing pictures or documents with large areas of image content, try increasing the top and bottom margins when printing in portrait mode or the left and right margins when printing in landscape mode. Start with a one-inch margin on top and bottom and a quarter-inch margin on the sides. The larger the margin, the less potential there is for curl. ▪ Print on a higher weight paper, such as 24 lb (90 gsm) paper or print on KODAK Ultimate Paper. ▪ Apply a border, rather than printing in borderless mode. ▪ If the paper is not stacking properly in the output tray, remove the pages as they exit.
Print quality	<ul style="list-style-type: none"> ▪ For best results, use KODAK Paper or a paper with the COLORLOK Technology logo on the package. ▪ Make sure the paper is loaded correctly. See Loading plain paper, page 26 and Loading photo paper, page 27. ▪ Clean the printhead: <ul style="list-style-type: none"> - Press Home. - Press ▼ to select Maintenance, then press OK. - Press ▼ to select Clean Printhead, then press OK. ▪ Calibrate the printer: <ul style="list-style-type: none"> - Press Home. - Press ▼ to select Maintenance, then press OK. - Press ▼ to select Calibrate Printer, then press OK. <p>For more information, go to www.kodak.com/go/aiosupport, then type the problem in the search field.</p>
Paper jam	<ul style="list-style-type: none"> ▪ Open the access door and gently pull paper out from the front, reaching through the opening above the paper output tray. ▪ If you cannot access the paper from the front, gently pull the jammed paper up from the paper input tray. ▪ Make sure the paper in the input tray is free of tears or creases. ▪ Make sure you do not overload the paper input tray. <p>For more information, go to www.kodak.com/go/esp2150support or www.kodak.com/go/esp2170support, then type Paper jam in the search field.</p>

Problem	Possible Solutions
Cannot send or receive a fax	<ul style="list-style-type: none"> ▪ Make sure that the wall phone line is plugged into the Line in port. ▪ Verify that the wall jack works by plugging in a phone and checking for a dial tone. ▪ Verify that Region is set to the correct country code. <ul style="list-style-type: none"> - Press Home. - Press ▼ or ▲ to select Printer Settings, then press OK. - Press ▼ to select Country/Region, then press OK. - Press ▼ or ▲ to select your country, then press OK. ▪ If you are connected to a DSL phone line, make sure you have a DSL filter connected to the phone jack. <p>For more information, go to www.kodak.com/go/esp2150support or www.kodak.com/go/esp2170support, then type Fax in the search field.</p>
Error codes/messages	<ul style="list-style-type: none"> ▪ Go to www.kodak.com/go/esp2150support or www.kodak.com/go/esp2170support, then type your error code or message.

Getting help on the Web

For more troubleshooting information:

Get help with wireless networking.	www.kodak.com/go/inkjetnetworking
Search our knowledge base of Questions and Answers.	www.kodak.com/go/esp2150support or www.kodak.com/go/esp2170support
Download the latest firmware and software for optimal printer performance.	www.kodak.com/go/esp2150downloads or www.kodak.com/go/esp2170downloads
Check the Extended User Guide for detailed instructions and the recommended system requirements	www.kodak.com/go/aiomanuals
Get help with problems you cannot resolve.	<p>Contact Kodak at www.kodak.com/go/contact and have the following information available:</p> <ul style="list-style-type: none"> - KODAK Service Number (located inside the printer when you open the printer access door) - Printer model number (located on the control panel above the LCD) - Computer model, operating system, and version of Home Center Software

Status lights

There are three status lights on the printer: the power status light (on the on/off button) indicates power, the Wi-Fi status light indicates Wi-Fi status, and the attention light blinks when an error occurs.

Power light

Power light	What it means
Off	<ul style="list-style-type: none"> ▪ The printer is turned off. <ul style="list-style-type: none"> - Press the power button to turn on power. ▪ The printer does not have power. <ul style="list-style-type: none"> - Make sure that the power cord is plugged into the back of the printer and into an electrical outlet, and that the electrical outlet has power.
Blinking	<ul style="list-style-type: none"> ▪ The printer is busy. <ul style="list-style-type: none"> - Wait for the printer to finish the task.
On	The printer is ready.

Wi-Fi connectivity LED

Wi-Fi connectivity LED	What it means
Off	The Wi-Fi radio is either turned off or is turned on but not connected to a wireless network.
Blinks continuously	The Wi-Fi radio is turned on, and the printer is searching for available wireless networks within range.
Blinks intermittently	<p>The Wi-Fi radio is turned on and the printer cannot find any available wireless networks within range, or the Wi-Fi radio connection has been interrupted, or is too weak to send signals to and from the printer.</p> <p>To find and connect to an available wireless network within range, press OK, turn the Wi-Fi radio off, and run the Wi-Fi Setup Wizard (see Connecting to a wireless network, page 15).</p>
On	The Wi-Fi radio is turned on, and there is a working connection between the printer and a wireless network.

The following specifications are subject to change without notice.

Features and Specifications

Print performance

- Black print speed** 6 images per minute
- Color print speed** 4 images per minute
- Print technology** Continuous-tone, thermal inkjet
- Print quality modes** Draft, Normal, and Best on plain paper
Photo quality mode on photo paper

Photo printing features

- Quantity** 1 to 99
- Print sizes** 2 x 3 in. / 5 x 8 cm
3.5 x 5 in. / 9 x 13 cm
4 x 6 in. / 10 x 15 cm
4 x 7 in. / 10 x 18 cm
4 x 8 in. / 10 x 20 cm
4 x 12 in. / 10 x 30 cm (Panoramic)
5 x 7 in. / 13 x 18 cm
8 x 10 in. / 20 x 25 cm
US Letter - 8.5 x 11 in. / 22 x 28 cm
A4 - 8.3 x 11.7 in. / 21 x 30 cm
- Quality** Best, Normal, Draft modes on plain paper
Photo quality mode on photo paper
- Auto-detect media** Auto-detect plain paper and photo papers
Optimize image quality for KODAK Photo Papers with barcode
- Image enhancement** KODAK PERFECT TOUCH Technology with
Home Center Software (from the computer only)
- Color** Black-and-white or color
- Scene balance** On (default), Off

Copy document features

- Color** Black-and-white or color
- Quantity** 1 to 99 copies
- Copy sizes** Same Size, Fit to Page, 20% to 500%
- Plain paper quality** Best, Normal, Draft
- Brightness** - 3 to + 3

Copy photo features

- Color** Black-and-white or color
- Quantity** 1 to 99
- Copy sizes** 2 x 3 in. / 5 x 8 cm
3.5 x 5 in. / 9 x 13 cm
4 x 6 in. / 10 x 15 cm
4 x 7 in. / 10 x 18 cm
4 x 8 in. / 10 x 20 cm
4 x 12 in. / 10 x 30 cm (Panoramic)
5 x 7 in. / 13 x 18 cm
8 x 10 in. / 20 x 25 cm
US Letter - 8.5 x 11 in. / 22 x 28 cm
A4 - 8.3 x 11.7 in. / 21 x 30 cm
- Quality** Automatic
- Brightness** - 3 to + 3

Scanning features

- Scanner type** Contact Image Sensor (CIS)
- Scan sizes** Maximum size of original scanned from platen:
8.5in. / 22 cm wide; 11.7 in. / 30 cm long

Sizes of originals scanned from ADF:
B5 (6.9 x 9.8 in. / 18 x 25 cm)
US Executive (7.3 x 10.5 in. / 18 x 27 cm)
US Letter (8.5 x 11 in. / 22 x 28 cm)
A4 (8.3 x 11.7 in. / 21 x 30 cm)
US Legal (8.5 x 14 in. / 22 x 36 cm)
- Functions** Segmentation scanning
Auto-destination
Optical Character Recognition (OCR)

Faxing features and specifications

Fax transfer rate 9600, 14400, or 33600 (default) baud

Fax memory 100 pages at 96 dpi text

Speed dials Up to 60

Resolution Standard: 200 x 100

Fine: 200 x 200

Photo: 300 x 300

Paper input tray

Paper capacity 150 sheets of 20 lb plain paper
20 sheets of photo paper, up to 12 mil (290 gsm)
20 envelopes

Tray size 4 x 6 in. to 8.5 x 14 in. / 10 x 15 cm to 22 x 36 cm

Automatic Document Feeder (ADF) for originals

Paper capacity 25 sheets (20 to 24 lb / 75 to 90 gsm) plain paper

Paper size limits 6.9 x 9.8 in. to 8.5 x 14 in. / 18 x 25 cm to 22 x 36 cm

Ink cartridges

Ink handling 2-cartridge, 4-ink system

Ink life 1-year warranty from date of purchase

Connectivity

Protocols supported USB 2.0 High Speed; DPOF

Devices supported WINDOWS OS-based and MACINTOSH Computers, memory cards (SD, MS/Duo, MMC, SDHC)

Image formats supported Image printing supports JPEG (EXIF v2.21 non-progressive); does not support progressive JPEG format; image scanning supports scanning to JPG and non-searchable PDF

Number of USB ports One USB 2.0 high-speed device port on the back of the printer

Wi-Fi technology supported 802.11b/g/n, WPA/WPA2, WPS, and WEP

Software support

- Application support** Third-party image-management software; optical character reader (OCR) support for documents
- Media support** Plain paper, photo paper, envelopes, greeting cards, card stock, and labels
- Scanner support** TWAIN and WIA, WIA2 (WINDOWS 7 and VISTA OS), ICA (MAC OS) and TWAIN (on MAC OS 10.4 and 10.5), including segmentation scanning
- Update support** Software and firmware updates available through Web support

Physical specifications

- Power** Input: 110–240 V AC, 50–60 Hz
Output: 36 V DC at 1.6 A
- Storage dimensions** 45.5 cm (17.9 in.) wide x 41.5 cm (16.3 in.) deep x 23.0 cm (9.1 in.) tall with input and output trays closed
- Operating dimensions** 45.5 cm (17.9 in.) wide x 65.0 cm (25.6 in.) deep x 29.6 cm (11.7 in.) tall with input and output trays fully extended for operation
- Weight** 6.9 kg (15.2 lb) without power supply, printhead, or ink cartridges
- Operating range** 5°C (41°F) to 35°C (95°F), 15 to 85% RH
- Full image quality environmental range** 15°C (59°F) to 30°C (86°F), and 20 to 80% RH
- Energy efficiency** ENERGY STAR® Qualified

Warranty

- Product** One year from purchase (with proof of purchase)
- Printhead** One year from purchase (with proof of purchase)

Minimum System requirements

Computer with WINDOWS OS

Computer Minimum

Operating System	WINDOWS 7, VISTA, or XP (SP2 or later)
CPU	INTEL CELERON Processor
Clock speed	1.2 GHz
Memory	512 MB RAM
Available hard disk space	500 MB available
Interface	USB 2.0 cable
CD drive	CD-ROM

Computer with MAC OS

Computer Minimum

Operating System	MACINTOSH OS X 10.4.8 or later
CPU	PowerPC G4, G5, or INTEL-based MAC
Clock speed	1.2 GHz
Memory	512 MB RAM
Available hard disk space	200 MB available
Interface	USB 2.0 cable
CD drive	CD-ROM

Paper types supported

- Plain paper** 16 to 24 lb (60 to 90 gsm)
- Photo paper** 6.5 to 12 mil
- Card stock** 110 lb index max (200 gsm)
- Envelopes** 20 to 24 lb (75 to 90 gsm)
- Transparencies** All commercially available inkjet varieties (with a white strip on the long edge) - 8.5 x 11 in. and A4 size
- Labels** All commercially available inkjet varieties on 8.5 x 11 in. and A4 size sheets
- Iron-on transfers** All commercially available inkjet varieties on 8.5 x 11 in. and A4 size sheets

Paper sizes supported

- Plain paper** A4 (8.3 x 11.7 in. / 21 x 30 cm)
A5 (5.8 x 8.3 in. / 15 x 21 cm)
A6 (4.1 x 5.8 in. / 11 x 15 cm)
B5 (6.9 x 9.8 in. / 18 x 25 cm)
US Executive (7.3 x 10.5 in. / 18 x 27 cm)
US Letter (8.5 x 11 in. / 22 x 28 cm)
US Legal (8.5 x 14 in. / 22 x 36 cm)
Custom sizes from 4-8.5 in. / 10-22 cm wide and 6-14 in. / 15-36 cm long
- Labels** A4 (8.3 x 11.7 in. / 21 x 30 cm)
US Letter (8.5 x 11 in. / 22 x 28 cm)
- Index card stock** 4 x 6 in. index cards (10 x 15 cm)
5 x 7 in. index cards (13 x 18 cm)
- Iron-on transfers** A4 (8.3 x 11.7 in. / 21 x 30 cm)
US Letter (8.5 x 11 in.) (22 x 28 cm)
- Envelopes** C5 (6.4 x 9 in. / 16 x 23 cm)
C6 (4.5 x 6.4 in. / 11 x 16 cm)
DL (designated long) (4.3 x 8.7 in. / 11 x 22 cm)
US #10 (4.1 x 9.5 in / 11 x 24 cm)
US #7¾ (3.9 x 7.5 in. / 10 x 19 cm)
US #9 (3.9 x 8.9 in. / 10 x 23 cm)

Photos 4 x 6 in. / 10 x 15 cm
4 x 7 in. / 10 x 18 cm
4 x 8 in. / 10 x 20 cm
4 x 12 in. / 10 x 31 cm
5 x 7 in. / 13 x 18 cm
7 x 10 in. / 18 x 25 cm
8 x 10 in. / 20 x 25 cm
US Letter (8.5 x 11 in. / 22 x 28 cm)
A4 (8.3 x 11.7 in. / 21 x 30 cm)

Safety information

KODAK ESP Office 2100 Series All-in-One Printers are Class 1 LED Products.

- Always follow all warnings and instructions marked on the product.
- Use only the power source indicated on the product regulatory label.
- Use only the power cord that comes with the product (or an approved power cord greater than or equal to H05W-F, 3G, 0.75 mm²). Using another power cord may cause fire and/or shock. Do not use the included power cord with any other equipment.
- Always turn this product off by using the On/Off button. Wait until the On/Off button stops flashing before removing the power plug from the outlet.
- Do not allow the power cord to become damaged or frayed.
- If you need to use an extension cord with this product, make sure that the ampere rating of the product does not exceed the ampere rating of the extension cord.
- Place the product on a flat, stable surface that extends beyond the product's base in all directions. This product will not operate properly if tilted or at an angle.
- When storing or transporting this product, do not tilt or stand it on its side. Never turn this product upside down (ink can leak out of the product).
- Avoid placing this product in an environment that is subject to rapid changes in temperature or humidity, mechanical shocks, vibration, or dust. Do not place near radiators, heating vents, or in direct sunlight.
- Leave enough room around this product for sufficient ventilation.
- Do not block this product's covers or openings, or insert any objects through slots.
- Do not use aerosol products inside or around this product.
- Do not spill any liquid on this product.
- Do not attempt to repair or service this product.
- If the power cord or plug is damaged, if any liquid has been spilled onto the product, if the product has been dropped or the case damaged, if the product does not operate normally or exhibits a major change in performance level, unplug this product and contact Kodak at www.kodak.com/go/contact.

For Service Personnel:



CAUTION:

Risk of explosion if battery is replaced by an incorrect type. Dispose of used batteries according to local instructions.

LCD screen safety

- Use only a dry, soft cloth to clean the LCD screen. Do not use any liquid or chemical cleaners.
- If the LCD screen is damaged, contact Kodak immediately. If any of the solution from the display gets on your hands, wash them thoroughly with soap and water.

Ink cartridge safety

- Keep all ink cartridges out of the reach of children.
- If ink gets on your skin, wash with soap and water. If ink gets into your eyes, flush immediately with water. If any discomfort or change in vision persists after washing, seek medical attention immediately.
- For MSDS information on inks, go to www.kodak.com/go/MSDS.

Regulatory compliance

FCC statement

The United States Federal Communications Commission (in CFR 47 Part 15.105) has specified that the following notice be brought to the attention of the users of this product:

NOTE: This equipment has been tested and found to comply with the limits for a Class B digital device, pursuant to part 15 of the FCC Rules. These limits are designed to provide reasonable protection against harmful interference in a residential installation. This equipment generates, uses, and can radiate radio frequency energy and, if not installed and used in accordance with the instructions, may cause harmful interference to radio communications. However, there is no guarantee that interference will not occur in a particular installation. If this equipment does cause harmful interference to radio or television reception, which can be determined by turning the equipment off and on, the user is encouraged to try to correct the interference by one or more of the following measures:

- Reorient or relocate the receiving antenna.
- Increase the separation between the equipment and receiver
- Connect the product into an outlet on a circuit different from that to which the receiver is connected.
- Consult the dealer or an experienced radio/TV technician for help.



CAUTION:

Pursuant to Part 15.21 of the FCC Rules, any changes or modifications to this product not expressly approved by Eastman Kodak Company might cause harmful interference and void the FCC authorization to operate this product.

The radiated energy from this product is well below the FCC radio frequency exposure limits. Nevertheless, the product shall be used in such a manner that the potential for human contact during normal operation is minimized. This product and any attached external antenna, if supported, shall be placed in such a manner to minimize the potential for human contact during normal operation. In order to avoid the possibility of exceeding the FCC exposure limits, human proximity shall not be less than 20 cm (8 inches) during normal operation.

Canadian statements

This product meets the applicable Industry Canada technical specifications.

Operation is subject to the following two conditions: (1) this device may not cause interference, and (2) this device must accept any interference, including interference that may cause undesired operation of the device.

This Class B digital apparatus complies with Canadian ICES-003.

Industry Canada (IC) Radiation Exposure Statement

This equipment complies with IC radiation exposure limits set forth for an uncontrolled environment. This equipment should be installed and operated with a minimum distance of 20 cm between the radiator and your person.

European compliance statement



Hereby, Eastman Kodak Company declares that this KODAK all-in-one wireless printer is in compliance with the essential requirements and other relevant provisions of Directive 1999/5/EC.

German compliance statement

Noise emissions for this equipment do not exceed 70 dB(A).

This equipment is not intended for use in the work place in accordance with BildscharbV regulations.

“Das Gerät ist nicht für die Benutzung am Bildschirmarbeitsplatz gemäß BildscharbV vorgesehen.”

REACH Article 33 declarations

Go to www.kodak.com/go/REACH for information about the presence of substances included on the candidate list according to article 59(1) of Regulation (EC) No. 1907/2006 (REACH).

Power supply information

Certified External Power Supply that can be used with this product: Hipro HP-A0601R3, or Flextronics VP-09500084-000.

Waste electrical and electronic equipment labeling

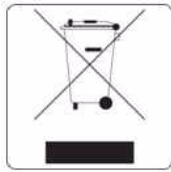

In the European Union, do not discard this product as unsorted municipal waste. Contact your local authorities or go to www.kodak.com/go/recycle for recycling program information.

ENERGY STAR® Qualified

To conserve energy, this printer will enter a reduced power (sleep) mode automatically after 1 hour. You can adjust the delay time (in 0.5 hour increments) up to 4 hours. Increasing the delay time may result in reduced energy savings.



ENERGY STAR and the ENERGY STAR mark are registered U.S. service marks. As an ENERGY STAR partner, Kodak has determined that this product meets ENERGY STAR Guidelines for energy efficiency. For more information on the ENERGY STAR program, see www.energystar.gov.

Warranty Information

Limited Warranty

Kodak warrants Kodak consumer electronic products and accessories ("Products"), excluding batteries, to be free from malfunctions and defects in both materials and workmanship for one year from the date of purchase. Retain the original dated sales receipt. Proof of the date of purchase will be required with any request for warranty repair.

Limited Warranty Coverage

Warranty service is only available from within the country where the Products were originally purchased. You may be required to send Products, at your expense, to the authorized service facility for the country where the Products were purchased. Kodak will repair or replace Products if they fail to function properly during the warranty period, subject to any conditions and/or limitations stated herein. Warranty service will include all labor as well as any necessary adjustments and/or replacement parts. If Kodak is unable to repair or replace a Product, Kodak will, at its option, refund the purchase price paid for the Product provided the Product has been returned to Kodak together with proof of the purchase price paid. Repair, replacement, or refund of the purchase price are the sole remedies under this warranty. If replacement parts are used in making repairs, those parts may be remanufactured or may contain remanufactured materials. If it is necessary to replace the entire Product, it may be replaced with a remanufactured Product. Remanufactured Products, parts and materials are warranted for the remaining warranty term of the original Product, or 90 days after the date of repair or replacement, whichever is longer.

Limitations

This warranty does not cover circumstances beyond Kodak's control. This warranty does not apply when failure is due to shipping damage, accident, alteration, modification, unauthorized service, misuse, abuse, use with incompatible accessories or attachments (such as third party ink or ink tanks), failure to follow Kodak's operation, maintenance or repacking instructions, failure to use items supplied by Kodak (such as adapters and cables), or claims made after the duration of this warranty. KODAK MAKES NO OTHER EXPRESS OR IMPLIED WARRANTY FOR THIS PRODUCT, AND DISCLAIMS THE IMPLIED WARRANTIES AND CONDITIONS OF MERCHANTABILITY AND FITNESS FOR A PARTICULAR PURPOSE. In the event that the exclusion of any implied warranty is ineffective under the law, the duration of the implied warranty will be one year from the purchase date or such longer period as required by law. The option of repair, replacement, or refund is Kodak's only obligation. Kodak will not be responsible for any special, consequential or incidental damages resulting from the sale, purchase, or use of this product regardless of the cause. Liability for any special consequential or incidental damages (including but not limited to loss of revenue or profit, downtime costs, loss of the use of the equipment, cost of substitute equipment, facilities or services or claims of your customers for such damages resulting from the purchase, use or failure of the Product), regardless of cause, or for breach of any written or implied warranty is expressly disclaimed.

Your Rights

Some states or jurisdictions do not allow exclusion or limitation of incidental or consequential damages, so the above limitation or exclusion may not apply to you. Some states or jurisdictions do not allow limitations on how long an implied warranty lasts, so the above limitation may not apply to you. This warranty gives you specific rights, and you may have other rights which vary from state to state or by

jurisdiction. Your statutory rights are not affected.

Outside the United States and Canada

In countries other than the United States and Canada, the terms and conditions of this warranty may be different. Unless a specific Kodak warranty is communicated to the purchaser in writing by a Kodak company, no warranty or liability exists beyond any minimum requirements imposed by law, even though defect, damage, or loss may be by negligence or other act.

Declaration of Conformity

See www.kodak.com/go/declarationofconformity.

Index

A

- access door, location, 9
- ADF (automatic document feeder)
 - loading, 30
 - location, 9
- ADF paper-edge guides, location, 9
- Apple Macintosh See Macintosh
- attention light
 - location, 10
- auto answer button, location, 10
- auto answer LED, location, 10
- auto answer, setting for faxing, 68

B

- back button, location, 10
- black-and-white
 - copies, 43, 46
 - fax, sending, 72
 - scanning, 59

C

- call waiting, disabling, 66
- cancel button, location, 10
- card slot, location, 9
- cleaning
 - document backing, 77
 - printer, 76
 - scanner glass, 77
- color
 - copies, 43, 46
 - fax, sending, 72
 - scanning, 59
- components, 9
- computer requirements, 97
- configuring printer settings, 12
- connecting to a wireless network, 15–22
 - additional printer, 21
 - from USB, 22–23
 - printer on additional computers, 21
- control panel
 - location, 9
 - numeric keypad, 70
- copy mode button, location, 10
- copying, 42–47
 - documents, 42–44
 - adjusting settings, 42–43
 - black-and-white, 43
 - brightness, 43, 44
 - color, 43
 - copy sizes, 94
 - darkening, 43, 44
 - enlarging, 43, 44
 - features, 94
 - fit to page, 43
 - lightening, 43, 44
 - number of copies, 43, 44
 - quality, 43
 - quantity, 43, 44
 - reducing, 43, 44
 - using default settings, 42
 - loading originals, 42
 - photos, 45–47
 - adjusting settings, 45–46
 - black-and-white, 46
 - brightness, 46, 47
 - color, 46
 - copy sizes, 94
 - darkening, 46, 47
 - enlarging, 45, 47
 - features, 94
 - lightening, 46, 47
 - number of copies, 45, 47
 - previewing on LCD, 46
 - quality, 46
 - quantity, 45, 47
 - reducing, 45, 47
 - sizes, 45
 - using default settings, 45

- country/region, setting, 12
- cover page, fax, 71

D

- darkening copies
 - documents, 43, 44
 - photos, 46, 47
- date and time, setting, 12
- declaration of conformity, 105
- defaults
 - resetting, 12, 84
 - save copy settings as
 - documents, 43
 - photos, 46
 - save scan settings as, 59
- defaults, printing photos, 38
- distinctive ring, 66
- document backing, cleaning, 77
- documents
 - paper sizes, 98
 - printing, 31–32
 - printing two-sided, 31–32
- downloading (updating)
 - printer firmware, 82–83
 - software, 82–83
- DPOF, 40
- DPOF (digital print order format) printing
 - See tagged images, printing
- duplexing, 31–32

E

ENERGY STAR qualification, 103
 energy-saving sleep mode, 12
 enlarging copies
 documents, 43, 44
 photos, 45, 47
 envelopes
 capacity, 28
 loading, 28
 sizes, 25, 98

F

fax mode button, location, 10
 faxing, 60—74
 activity log, 67
 answering machine setup, 63
 answering service setup, 64
 brightness and resolution, 72
 call waiting
 disable code, 66
 disabling, 66
 confirmation page, 66
 cover page, 67, 71
 darkening, 72
 dedicated phone line setup, 63
 dialing mode
 pulse, 67
 tone, 67
 distinctive ring, 66
 error correction mode, 67
 header information, entering, 64
 lightening, 72
 loading originals, 71
 phonebook, 68
 adding entries, 69
 deleting entries, 70
 editing entries, 69
 preparing transmission, 71
 printing fax settings, 67
 receiving, 73—74
 automatically, 73
 manually, 74
 resolution and brightness, 72
 rings to answer, 65
 sender information, entering, 64
 sending, 72—73
 using numeric keypad, 73
 using phonebook, 72
 using quick dial, 73
 using redial button, 73
 set up, 60
 setting answer mode, 68
 setting options, 65—67

shared phone line setup, 63
 finding photos, 34, 38
 firmware, downloading (updating), 82—83

G

glass, scanner
 cleaning, 77
 location, 9
 graph paper, printing, 33
 grocery list, printing, 33

H

home button, location, 10
 Home Center Software, 11, 48, 50, 56, 83
 hostname, printer, 20

I

Image Capture software, 41
 image formats supported, 95
 index card stock, sizes, 98
 ink cartridges, replacing, 79—81
 ink levels, 84
 IP address
 setting up, 19
 viewing, 20
 iPhoto software, 41
 iron-on transfers, sizes, 24, 98

K

keyboard on LCD, using, 16
 KODAK All-in-One Printer Software, 11
 KODAK Home Center Software
 See Home Center Software
 KODAK Pic Flick App, 40

L

label sizes, 98
 language, setting, 12
 LCD screen, location, 10
 lightening copies
 documents, 43, 44
 photos, 46, 47
 loading originals
 for copying, 42
 for faxing, 71
 for scanning, 55
 on scanner glass, 29
 using ADF, 30
 loading paper input tray
 envelopes, 28
 photo paper, 27
 plain paper, 26

M

MAC address, viewing, 20
 media supported, 98
 memory card slot, location, 9
 memory cards, printing from, 35

N

narrow-ruled paper, printing, 33
 navigation buttons, location, 10
 network, wireless
 See wireless network
 numeric keypad on control panel, using, 70
 numeric keypad, location, 10

O

OK button, location, 10
 Online Printer Management Tool, 13–14
 accessing, 14
 using to configure printer settings, 14
 originals, loading
 for copying, 42
 for faxing, 71
 for scanning, 55
 on scanner glass, 29
 using ADF, 30
 output tray extender, location, 9

P

panoramic pictures, printing, 39
 paper, 24–30
 loading input tray
 envelopes, 28
 photo paper, 27
 plain paper, 26
 sizes, 98
 sizes supported, 24
 types, 98
 types supported, 24
 paper input tray
 capacity
 envelopes, 28
 photo paper, 27
 plain paper, 26
 location, 9
 paper output tray, location, 9
 paper tray
 capacity, 95
 paper-edge guides, location, 9
 phone port, location, 9
 phonebook
 adding new entries, 69
 deleting entries, 70
 editing entries, 69
 phonebook button, location, 10

photo mode button, location, 10
 photo paper
 capacity, 27
 loading, 27
 photo paper sizes, 99
 photo printing
 image enhancement, 93
 print sizes, 93
 quality, 93
 scene balance, 93
 photos
 finding, 34
 printing, 33–40
 viewing, 34
 Pic Flick App, 40
 pictures
 printing, 33–40
 DPOF, 40
 tagged, 40
 transferring to computer, 41
 plain paper
 capacity, 26
 loading, 26
 ports
 phone line for faxing, 9
 USB, 9
 power button, location, 10
 power cord connection port, location, 9
 printer
 cleaning instructions, 76
 defaults, resetting, 12, 84
 hostname, 20
 maintaining, 76–88
 settings, configuring, 12
 supplies
 recycling, 76
 printer connection, changing USB to wireless, 22
 printhead
 removing, 86
 replacing, 85–88
 printhead, location, 9
 printing, 31–41
 documents, 31–32
 two-sided, 31–32
 forms, 33
 pictures, 33–40
 DPOF, 40
 from memory card, 35
 from USB-connected device, 35
 panoramic, 39
 tagged, 40
 tagged images, 12
 speed, 93
 two-sided documents, 31–32

Q

quick dial, 69

R

receiving fax, 73—74

 automatically, 73

 manually, 74

recycling printer or supplies, 76

redial button, location, 10

reducing copies

 documents, 43, 44

 photos, 45, 47

regulatory compliance, 101

 Canadian, 102

 European, 102

 German, 102

 REACH Article 33 declarations, 103

 waste labeling, European Union, 103

reminder list, printing, 33

replacing

 ink cartridges, 79—81

 printhead, 85—88

resolution, scanning, 49, 50

rings to answer, 65

S

safety information, 100—101

scan mode button location, 10

scanner glass

 cleaning, 77

 location, 9

scanner lid, location, 9

scanner type, 94

scanning, 48—59

 automatically detect pictures, 50

 features, 94

 file format

 document, 49

 picture, 50

 from computer, 56

 from control panel, 57—59

 from Online Printer Management Tool, 59

 loading originals, 55

 multiple pictures simultaneously, 56

 resolution, 49, 50

 selecting quality, 50

 setting options, 58—59

Service Set Identifier, 15

setting options, 37—38

settings

 copy documents, 42—43

 copy photos, 45—46

 fax, 65—67

 printing

 photos, 37—38

 scanning, 58—59

 sheet music, printing, 33

 sleep mode, 12

 software

 downloading (updating), 82—83

 support, 96

 specifications, 93—99

 physical dimensions, 96

 power, 96

 weight, 96

 SSID, 15

 Start black button, location, 10

 Start color button, location, 10

 supplies, ordering, 12

 system requirements, minimum, 97—99

T

telephone service

 cable, 60

 digital subscriber line (DSL), 60, 61

 Internet (VOIP), 60

 standard, 60

tic-tac-toe, printing, 33

time and date, setting, 12

time to low power, setting, 12

transferring pictures to computer, 41

transparencies, 24

tray, paper input, capacity

 envelopes, 28

 photo paper, 27

 plain paper, 26

troubleshooting, 89—92

two-sided printing, 31—32

U

updating

 firmware, 82—83

 software, 82—83

USB connection, changing to wireless, 22—23

USB ports

 location, 9

USB-connected device, printing from, 35

V

viewing photos, 34

W

warranty, 96, 103—105

 ink, 95

Web support

 contact information, 100

- Electronics Industry Alliance, 76
- ENERGY STAR program, 103
- iPhone, iPad, and iPod Touch devices, 33, 40
- Material Safety Data Sheets (MSDS), 101
- networking, 17, 19, 89
- Pic Flick App, 33, 40
- REACH Article 33 declarations, 103
- recycling, 76
- wide-ruled paper, printing, 33
- Wi-Fi
 - technology supported, 95
- Wi-Fi connectivity LED, location, 10
- Wi-Fi Setup wizard, 15
- wireless network
 - configuration, viewing and printing, 20
 - connecting to, 15—22
 - additional KODAK All-in-One Printer(s), 21
 - from USB, 22
 - non-WPS router, 15
 - printer on additional computers, 21
 - using Wi-Fi Setup wizard, 15
 - WPS router, 17
 - IP address, setting up, 19
 - settings, configuring, 15
 - subnet, viewing, 20
- WPS, 15
- WPS router, 17

Free Manuals Download Website

<http://myh66.com>

<http://usermanuals.us>

<http://www.somanuals.com>

<http://www.4manuals.cc>

<http://www.manual-lib.com>

<http://www.404manual.com>

<http://www.luxmanual.com>

<http://aubethermostatmanual.com>

Golf course search by state

<http://golfingnear.com>

Email search by domain

<http://emailbydomain.com>

Auto manuals search

<http://auto.somanuals.com>

TV manuals search

<http://tv.somanuals.com>