



# 2400DSV

## Service Manual

---

# Kodak

---

## PREFACE

This Service Manual explains the Microfilm Scanner already put on the market.

It is hoped that this Service Manual will help to provide for more effective machine maintenance in the field there by ensuring optimum machine performance.

Microfilm Scanner MS6000

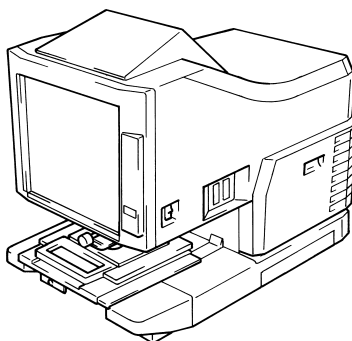

All information in this Manual is subject to change without prior notice.

This manual has not described the printer section.  
Separately, refer to the Service Manual of the Printer.

# Contents

<b>1</b>	<b>Safety Precautions for Inspection and Service</b>	
1.1	WARNING.....	1
1.2	CAUTION.....	4
1.3	Other Precautions.....	6
1.4	Used Batteries Precautions .....	7
<b>2</b>	<b>Installation</b>	
2.1	Installation Environment .....	8
2.2	Usage Environment .....	8
2.3	Installing The Power Supply .....	9
2.4	Installation Space.....	9
<b>3</b>	<b>General Information</b>	
3.1	Specifications.....	10
3.1.1	MS 6000 .....	10
3.1.2	MS 6000 & MSP3000 Printer System .....	12
3.1.3	MS 6000 & MSP2000 Printer System .....	12
3.2	System Configuration.....	13
3.3	Connection Mode.....	14
3.3.1	PR Mode (Scanner + Printer) .....	14
3.3.2	PC Mode (Scanner + Personal Computer).....	14
3.4	Parts Identification.....	15
3.5	Component Layout .....	16
3.6	Electrical Components Layout .....	17
3.7	Electrical Parts Function .....	20
3.8	Connectors Layout .....	22
3.9	Electrical Service Parts on P.W.Boards.....	24
3.9.1	Main Control Board (PWB-BB).....	24
3.9.2	I/F Board (PWB-EE) .....	24
3.9.3	I/F Board (PWB-SS) .....	25
3.9.4	Main Power Unit (PU1).....	25
3.9.5	Projection Lamp Regulator (PU2) .....	25
3.9.6	Optional Power Unit (PU3) .....	25

<b>3.10 Explanation of Control Panel .....</b>	<b>26</b>
3.10.1 Control Panel (Basic) .....	26
3.10.2 Control Panel (Shift Function) .....	33
<b>3.11 Image Processing .....</b>	<b>35</b>
<b>4 Mechanical and Electrical</b>	
<b>4.1 Illumination Mechanism .....</b>	<b>37</b>
4.1.1 Overview .....	37
4.1.2 Projection Lamp (LA1) .....	37
4.1.3 Projection Lamp Voltage Control Circuit .....	38
4.1.4 Thermostat (TS1) .....	39
4.1.5 Condenser Lens .....	40
4.1.6 Projection Lens .....	41
<b>4.2 Image Rotation .....</b>	<b>42</b>
4.2.1 Prism Rotation .....	42
4.2.2 Auto Image Rotating Motor (M5) Control Circuit .....	42
<b>4.3 Optical Section .....</b>	<b>43</b>
4.3.1 Overview .....	43
4.3.2 Reader Path .....	44
4.3.3 Scan Path .....	44
4.3.4 Scan Table Drive Mechanism .....	45
4.3.5 Scan Mirror Motion Control .....	46
4.3.6 Mirror Scan Motor (M1) Control Circuit .....	47
<b>4.4 CCD Section .....</b>	<b>48</b>
<b>4.5 Image Bus .....</b>	<b>49</b>
<b>4.6 Auto Masking .....</b>	<b>52</b>
4.6.1 Overview .....	52
4.6.2 Masking Area Detection .....	52
4.6.3 Requirements for Auto Masking .....	52
<b>4.7 Auto Image Skew Correction .....</b>	<b>55</b>
4.7.1 Overview .....	55
4.7.2 Requirements for Auto Skew Correction .....	55
<b>4.8 Manual Frame Masking .....</b>	<b>56</b>
<b>4.9 2 to 1 Printing Function .....</b>	<b>57</b>
4.9.1 Overview .....	57
4.9.2 Operation .....	57
4.9.3 Identification Marks .....	58
<b>5 Disassembly and Cleaning</b>	
<b>5.1 Precautions .....</b>	<b>59</b>

5.1.1	Precautions for Disassembly and Cleaning.....	59
<b>5.2</b>	<b>Handling of P.W.Boards .....</b>	<b>60</b>
5.2.1	Precautions regarding transportation and storage .....	60
5.2.2	Precautions when replacing PWBs .....	60
5.2.3	Precautions when checking PWBs.....	60
<b>5.3</b>	<b>Maintenance and Inspection .....</b>	<b>61</b>
5.3.1	Preventive Maintenance Schedule List .....	61
5.3.2	Details of readjustments needed when parts are replaced .....	61
<b>5.4</b>	<b>Disassembly and Cleaning Procedure .....</b>	<b>62</b>
5.4.1	Removal of the Outer Covers.....	62
5.4.2	Replacing of the Projection Lamp .....	65
5.4.3	Cleaning of the Projection Lamp .....	66
5.4.4	Cleaning of the Condenser Lens and Mirrors.....	66
5.4.5	Cleaning of the each Mirrors .....	67
5.4.6	Cleaning of the CCD Filter .....	68
5.4.7	Removal of the CCD Assy.....	69
5.4.8	Removal of the Power Unit.....	71
5.4.9	Removal of the P.W.Boards. ....	72
5.4.10	Replacing Scan Motor bushing and friction plate .....	73
5.4.11	Replacing the Fuse of the Power Unit.....	73
5.4.12	Replacing the Main Fuse.....	74
5.4.13	Exchanging the Oscillator Chip .....	75

## 6 Function Mode and Adjustment

<b>6.1</b>	<b>Precautions.....</b>	<b>77</b>
<b>6.2</b>	<b>Overview .....</b>	<b>77</b>
<b>6.3</b>	<b>Function Mode List .....</b>	<b>78</b>
6.3.1	S mode (Setting Function 1).....	78
6.3.2	y mode (Setting Function 2) .....	79
6.3.3	o mode (Setting Function 3) .....	80
6.3.4	F mode (machine operation checks).....	81
6.3.5	b mode (machine operation checks) .....	81
6.3.6	About the Function Mode Setting Label .....	82
<b>6.4</b>	<b>Operation of the Function Mode.....</b>	<b>83</b>
6.4.1	Entering the Function Mode .....	83
6.4.2	Execution method in F and b mode (except F4, F8 and b6) .....	83
6.4.3	Execution method in F and b mode (F4, F8 and b6).....	84
6.4.4	Execution method in S, y and o mode.....	84
6.4.5	Leaving the Function Mode .....	84
<b>6.5</b>	<b>S mode Operations .....</b>	<b>85</b>
6.5.1	S1: Auto Reset .....	85
6.5.2	S2: Auto Power Save .....	85

6.5.3	S3: Auto Projection Lamp OFF .....	85
6.5.4	S4: Coin Vender / Foot Switch Setting.....	85
6.5.5	S5: Fine Mode Setting .....	86
6.5.6	S6: Paper Tray feed size (MSP 3000 Printer).....	86
6.5.7	S7: Machine ID Printing .....	86
6.5.8	S8: Cycle print mode.....	87
6.5.9	S9: Nega Contrast Adjustment .....	87
6.5.10	SA: Posi Contrast Adjustment.....	87
6.5.11	Sb: Scan Table Stop Position Adjustment (Scan Position).....	88
6.5.12	SC: Scan Table Stop Position Adjustment (Reader Position).....	88
6.5.13	Sd: Auto image rotation 90 degree rotation function.....	89
6.5.14	SE: The print function at the time of Toner Empty detection .....	89
<b>6.6</b>	<b>y mode Operations .....</b>	<b>90</b>
6.6.1	y2: Auto Paper Source Switching .....	90
6.6.2	y3: Auto Film Format Select Print .....	90
6.6.3	y5: Memo Image Masking.....	90
6.6.4	y6: Prescan Operation .....	91
6.6.5	y7: Auto Skew Correction Retain .....	91
6.6.6	yb: Magnification Warning Display.....	91
6.6.7	yC: Print Reserve Function .....	91
<b>6.7</b>	<b>o mode Operations .....</b>	<b>92</b>
6.7.1	o1: Inch/Metric Select .....	92
6.7.2	o2: N-P Auto Exposure Coarse Adjustment.....	92
6.7.3	o3: P-P Auto Exposure Coarse Adjustment.....	93
6.7.4	o4: Scan Speed Adjustment .....	94
6.7.5	o5: Adjustment of the image area Lengthwise Position .....	95
6.7.6	o6: Adjustment of the Top and Bottom Frame Black Band Width..	96
6.7.7	o7: Adjustment of the Right and Left Frame Black Band Width.....	97
6.7.8	o8: Projection lamp burn out detection (L2) setting .....	98
6.7.9	oA: Host Driver Setting .....	98
6.7.10	ob: Vender/Model Name Setting.....	98
<b>6.8</b>	<b>F mode Operations .....</b>	<b>99</b>
6.8.1	F1: ROM Version Check .....	99
6.8.2	F2: Scan Counter.....	99
6.8.3	F3: Print Counter.....	99
6.8.4	F4: Counter Clear .....	99
6.8.5	F5: Control Panel LED Check.....	99
6.8.6	F6: For Factory use.....	99
6.8.7	F7: Projection Lamp Voltage Adjustment.....	100
6.8.8	F8: Reset the Setting Data.....	101
<b>6.9</b>	<b>b mode Operations .....</b>	<b>102</b>
6.9.1	b1: Checking the Scan Table Unit Function.....	102
6.9.2	b2: Scanning mirror operation check .....	102
6.9.3	b3: For Factory use.....	102

6.9.4	b4: Prism rotation operation check .....	103
6.9.5	b5: Single scan operation check .....	103
6.9.6	b6: Shading Correction.....	104
6.9.7	b7: Test Print Function .....	105
6.9.8	b8: For Factory use .....	105

## 7 Troubleshooting

<b>7.1</b>	<b>How to Use This Section .....</b>	<b>106</b>
<b>7.2</b>	<b>Malfunction Indications .....</b>	<b>107</b>
<b>7.3</b>	<b>Malfunction Detection Timing.....</b>	<b>108</b>
7.3.1	L2: Projection Lamp malfunction .....	108
7.3.2	C1: Scan Unit Drive malfunction .....	108
7.3.3	C2: Scan Mirror Drive malfunction .....	108
7.3.4	C3: Shading Correction malfunction.....	109
7.3.5	C4: Cooling Fan Motor malfunction.....	109
7.3.6	Cb: Communication Error.....	109
7.3.7	CL: Printer Clock malfunction .....	109
<b>7.4</b>	<b>Troubleshooting for malfunction code .....</b>	<b>110</b>
7.4.1	L2: Projection Lamp malfunction .....	110
7.4.2	C1: Scan Unit Drive Malfunction .....	110
7.4.3	C2: Scan Mirror Drive malfunction .....	110
7.4.4	C3: Shading Correction malfunction.....	111
7.4.5	C4: Cooling Fan Motor malfunction.....	111
7.4.6	Cb: Communication Error.....	111
7.4.7	CL: Printer Clock malfunction .....	112
<b>7.5</b>	<b>Troubleshooting for malfunction.....</b>	<b>113</b>
7.5.1	No Power.....	113
7.5.2	The Projection Lamp does not Light Up .....	113
<b>7.6</b>	<b>Electrical Components Check .....</b>	<b>114</b>
7.6.1	LA1: Projection Lamp .....	114
7.6.2	M3: Power Unit Cooling Fan Motor .....	114
7.6.3	M4: Projection Lamp Cooling Fan Motor .....	114
7.6.4	PC1: Image Leading Edge Sensor.....	114
7.6.5	PC2: Scan Mirror Position Sensor.....	114
7.6.6	PC3: Reader Position Sensor .....	115
7.6.7	PC4: Scan Position Sensor .....	115
7.6.8	PU1: Power Unit.....	115
7.6.9	PU2: Projection Lamp Regulator .....	115
7.6.10	S1: Power Switch .....	115
7.6.11	S201: Interlock Switch.....	116
7.6.12	TS1: Thermostat.....	116
<b>7.7</b>	<b>Image Troubleshooting .....</b>	<b>117</b>

# 1 Safety Precautions for Inspection and Service

When performing inspection and service procedures, observe the following precautions to prevent accidents and ensure utmost safety.

\*Depending on the model, some of the precautions given in the following do not apply.

Different markings are used to denote specific meanings as detailed below.



## **WARNING**

Indicates a potentially hazardous situation which, if not avoided, could result in death or serious injury.



## **CAUTION**

Indicates a potentially hazardous situation which, if not avoided, may result in minor or moderate injury. It may also be used to alert against unsafe practices.

The following graphic symbols are used to give instructions that need to be observed.



Used to call the service engineer attention to what is graphically represented inside the marking (including a warning).



Used to prohibit the service engineer from doing what is graphically represented inside the marking.



Used to instruct the service engineer to do what is graphically represented inside the marking.

## 1.1 WARNING

1. Always observe precautions.



- Parts requiring special attention in this product will include a label containing the mark shown on the left plus precautionary notes. Be sure to observe the precautions.
- Be sure to observe the "Safety Information" given in Operator's Manual.



2. Before starting the procedures, be sure to unplug the power cord.



- This product contains a high-voltage unit and a circuit with a large current capacity that may cause an electric shock or burn.
- The product also contains parts that can jerk suddenly and cause injury.
- If this product uses a laser, laser beam leakage may cause eye damage or blindness.

3. Use the specified parts.



- For replacement parts, always use the genuine parts specified in the manufacturer's Parts Manual. Installing a wrong or unauthorized part could cause dielectric breakdown, overload, or undermine safety devices resulting in possible electric shock or fire.
- Replace a blown electrical fuse or thermal fuse with its corresponding genuine part specified in the manufacturer's Parts Manual. Installing a fuse of a different make or rating could lead to a possible fire. If a thermal fuse blows frequently, the temperature control system is probably of a problem and action must be taken to eliminate the cause of the problem.

4. Handle the power cord with care and never use a multiple socket.



- Do not brake, crush or otherwise damage the power cord. Placing a heavy object on the power cord, or pulling or bending it may damage it, resulting in a possible fire or electric shock.
- Do not use a multiple outlet to which any other appliances or machines is connected.
- Be sure the power outlet meets or exceeds the specified capacity.

5. Be careful about the high-voltage parts.



- A part marked with the symbol shown on the left carries a high voltage. Touching it could result in an electric shock or burn. Be sure to unplug the power cord before servicing this part or the parts near it.

6. Do not keep your hands wet when performing the procedures.



- Do not unplug or plug in the power cord, or perform any kind of service or inspection with wet hands. Doing so could result in an electric shock.

## 7. Do not touch a high-temperature part.

	<ul style="list-style-type: none"><li>• A part marked with the symbol shown on the left and other parts such as the exposure lamp and fusing roller can be very hot while the machine is energized. Touching them may result in a burn.</li><li>• Wait until these parts have cooled down before replacing them or any surrounding parts.</li></ul>
---	---

8. Make a ground connection at all times  
(This item may not be effected in USA).

	<ul style="list-style-type: none"><li>• Be sure to connect a ground wire to the ground terminal even when performing an inspection or repair. Without proper grounding, electrical leakage could result in an electric shock or fire.</li><li>• Never connect the ground wire to a gas pipe, water pipe, telephone ground wire, or a lightning conductor.</li></ul>
---	---

## 9. Do not remodel the product.



	<ul style="list-style-type: none"><li>• Modifying this product in a manner not authorized by the manufacturer may result in a fire or electric shock. If this product uses a laser, laser beam leakage may cause eye damage or blindness.</li></ul>
---	---

## 10. Restore all parts and harnesses to their original positions.



	<ul style="list-style-type: none"><li>• To promote safety and prevent product damage, make sure the harnesses are returned to their original positions and properly secured in their clamps and saddles in order to avoid hot parts, high-voltage parts, and sharp edges, or being crushed.</li><li>• To promote safety, make sure that all tubing and other insulating materials are returned to their original positions. Make sure that floating components mounted on the circuit boards are at their correct distance and position off the boards.</li></ul>
---	---

## 1.2 CAUTION

### 1. Precautions for Service Jobs

	<ul style="list-style-type: none"> <li>• A toothed washer and spring washer, if used originally, must be reinstalled. Omitting them may result in contact failure which could cause an electric shock or fire.</li> <li>• When reassembling parts, make sure that the correct screws (size, type) are used in the correct places. Using the wrong screw could lead to stripped threads, poorly secured parts, poor insulating or grounding, and result in a malfunction, electric shock or injury.</li> </ul>
	<ul style="list-style-type: none"> <li>• Take great care to avoid personal injury from possible burrs and sharp edges on the parts, frames and chassis of the product.</li> <li>• When moving the product or removing an option, use care not to injure your back or allow your hands to be caught in mechanisms.</li> </ul>

### 2. Precautions for Servicing with Covers and Parts Removed

	<ul style="list-style-type: none"> <li>• Wherever feasible, keep all parts and covers mounted when energizing the product.</li> <li>• If energizing the product with a cover removed is absolutely unavoidable, do not touch any exposed live parts and use care not to allow your clothing to be caught in the moving parts. Never leave a product in this condition unattended.</li> </ul>
	<ul style="list-style-type: none"> <li>• Never place disassembled parts or a container of liquid on the product parts falling into, or the liquid spilling inside, the mechanism could result in an electric shock or fire.</li> <li>• Never use a flammable spray near the product. This could result in a fire.</li> <li>• Make sure the power cord is unplugged before removing or installing circuit boards or plugging in or unplugging connectors.</li> <li>• Always use the interlock switch actuating jig to actuate an interlock switch when a cover is opened or removed. The use of folded paper or some other object may damage the interlock switch mechanism, possibly resulting in an electric shock, injury or blindness.</li> </ul>

### 3. Precautions for Working Environment

	<ul style="list-style-type: none"> <li>• The product must be placed on a flat, level surface that is stable and secure.</li> <li>• Never place this product or its parts on an unsteady or tilting workbench when servicing.</li> <li>• Provide good ventilation at regular intervals if a service job must be done in a confined space for a long period time.</li> <li>• Avoid dusty locations and places exposed to oil mist or steam.</li> <li>• Avoid working positions that may block the ventilation port of the product.</li> </ul>
---	---

### 4. Precautions for Handling Batteries

	<ul style="list-style-type: none"> <li>• Replace a rundown battery with the same type as specified in the manufacturer's parts manual.</li> <li>• Before installing a new battery, make sure of the correct polarity of the installation or the battery could burst.</li> <li>• Dispose of used batteries according to the local regulations. Never dispose of them at the user's premises or attempt to try to discharge one.</li> </ul>
---	---

### 5. Precautions for Laser Beam (Products Employing Laser Only)

	<ul style="list-style-type: none"> <li>• Removing the cover marked with the following caution label could lead to possible exposure to the laser beam, resulting in eye damage or blindness. Be sure to unplug the power cord before removing this cover.</li> <li>• If removing this cover while the power is ON is unavoidable, be sure to wear protective laser goggles that meet specifications.</li> <li>• Make sure that no one enters the room when the machine is in this condition.</li> <li>• When handling the laser unit, observe the "Precautions for Handling Laser Equipment."</li> </ul>
	<div style="border: 1px solid black; padding: 5px; margin-bottom: 10px;"> <p>注意- ここを開くと不可視レーザー光が出ます。ビームを直接視たり、触れたりしないでください。                  CAUTION- INVISIBLE LASER RADIATION WHEN OPEN AVOID EXPOSURE TO BEAM                  VORSICHT- UNSICHTBARE LASERSTRAHLUNG WENN ABDECKUNG GEÖFFNET NICHT DEM STRAHL AUSSETZEN                  ADVARSEL- USYNLIG LASERSTRÅLING NÅR DEKSEL ÅPNES UNNGÅ EKSPONERING FOR STRÅLEN                  VARO! AVATTAESSA OLET ALTTIINA NÄKYMÄTTÖMÄLLE LASERSÄTELYLLE ÄLÄ KATSO SÄTEESEEN                  ADVARSEL- USYNLIG LASERSTRÅLING VED ÅBNING UNDGÅ UDSÆTTELSE FOR STRÅLING                  VARNING- OSYNLIG LASERSTRÅLNING NÅR DENNA DEL ÄR ÖPPNAD STRÅLEN ÄR FARLIG                  注意！ 当蓋打开反照时，会发出肉眼看不见的光束射線，請不要直接或接觸光線。</p> </div> <p>1167P001AA</p>
	<div style="border: 1px solid black; padding: 5px; margin-bottom: 10px;"> <p style="text-align: center;"><b>⚠ DANGER</b></p> <p style="text-align: center;">Invisible laser radiation when open.  <b>AVOID DIRECT EXPOSURE TO BEAM</b></p> <p style="text-align: right; font-size: small;">0947-7127-01</p> </div> <p style="text-align: right; font-size: x-small;">1144D270AA</p>

### 1.3 Other Precautions

- To reassemble the product, reverse the order of disassembly unless otherwise specified.
- While the product is energized, do not unplug or plug connectors into the circuit boards or harnesses.
- The magnet roller generates a strong magnetic field. Do not bring it near a watch, floppy disk, magnetic card, or CRT tube.
- An air gun and vacuum cleaner generates a strong electrostatic charge that can destroy the ATDC sensor and other sensors. Before cleaning a component with one of these devices, be sure to remove all the sensors. Otherwise, use a blower brush and cloth when cleaning parts.
- When handling circuit boards with MOS ICs, observe the “INSTRUCTIONS FOR HANDLING THE PWBs WITH MOS ICs” (applicable only to the products using MOS ICs).
- The PC Drum is a very delicate component. Observe the precautions given in “HANDLING OF THE PC DRUM” because mishandling may result in serious image problems.
- Note that replacement of a circuit board may call for readjustments or resetting of particular items, or software installation.
- After completing a service job, perform a safety check. Make sure that all parts, wiring and screws are returned to their original positions.
- Check the area surrounding the service site for any signs of damage, wear or need of repair.
- Do not pull out the toner hopper while the toner bottle is turning. This could result in a damaged hopper motor or locking mechanism.
- If the product is to be run with the front door open, make sure that the toner hopper is in the locked position.

## 1.4 Used Batteries Precautions

(ALL Areas)

**CAUTION**

Danger of explosion if battery is incorrectly replaced.

Replace only with the same or equivalent type recommended by the manufacturer.

Dispose of used batteries according to the manufacturer's instructions.

(Germany only)

**VORSICHT!**

Explosionsgefahr bei unsachgemäßen austausch der batterie.

Ersatz nur durch denselben oder einen vom hersteller empfohlenen ähnlichen typ.

Entsorgung gebrauchter batterien nach angaben des herstellers.

(France)

**ATTENTION**

Ily a danger d'explosion s'ily a remplacement incorrec de la batterie.

Remplacer uniquement avec une batterie du meme type ou d'un type équivalent recommande par le constructeur.

Mettre au rebut les batteries usagées conformément aux instructions du fabricant.

(Denmark only)

**ADVARSEL!**

Lithiumbatteri - Eksplosionsfare ved fejlagtig håndtering Udskiftning må kun ske med batteri af samme fabrikat og type.

Levér det brugte batteri tilbage til leverandøren.

(Norway only)

**ADVARSEL**

Eksplosjonsfare ved feilaktig skifte av batteri.

Benytt samme batteritype eller en tilsvarende type anbefalt av apparatfabrikanten.

Brukte batterier kasseres i henhold til fabrikantens instruksjoner.

(Sweden only)

**VARNING**

Explosionsfara vid felaktigt batteribyte.

Använd samma batterityp eller en ekvivalent typ som rekommenderas av apparattillverkaren.

Kassera använt batteri enligt fabrikantens instruktion.

(Finland only)

**VAROITUS**

Paristo voi räjähtää, los se on virheellisesti asennettu.

Vaihda paristo ainoastaan laitevalmistajan suosittelemaan tyyppiin.

Hävittä Käytetty paristo valmistajan ohjeiden mukaisesti.

## 2 Installation

### 2.1 Installation Environment

To ensure safety and utmost performance of the machine, the machine should not be used in a place.

1. Where it will be subject to extremely high or low temperature or humidity.
2. Which is exposed to direct sunlight.
3. Which is in the direct air stream of an air conditioner, heater, or ventilator.
4. Which puts the operators in the direct air stream of exhaust of the machine.
5. Which has poor ventilation.
6. Where ammonia gas might be generated.
7. Where it will be subject to sudden fluctuations in either temperature or humidity.
8. Which is near any kind of heating device.
9. Which does not have stable, level floor.
10. Where it may be splashed with water.
11. Which is dirty or where it will receive undue vibration.
12. Which is near volatile flammables or curtains.



---

**NOTE:**

- If the machine is placed near a window, insure that the Screen faces inside, not the window.
- 

### 2.2 Usage Environment

In order to make sure the machine functions in good condition, please make sure the ambient environment satisfies the following requirements:

Temperature: 10-35°C    Temperature fluctuation:  $\pm 10^{\circ}\text{C}$  per hour or less

Humidity: 15-85%    Humidity fluctuation:  $\pm 20\%$  per hour or less

## 2.3 Installing The Power Supply

1. Do not plug the Power Cord into a power outlet via an extension cord supplying electricity to more than one unit.
2. Do not connect the machine to a power outlet used for other equipment or appliances.
3. More than one appliance connected to a single outlet could cause a drop or surge in the electrical supply, resulting in operational problems for the machine.
  - Voltage fluctuation: Specified voltage:  $\pm 10\%$
  - Frequency fluctuation: Specified frequency:  $\pm 3\text{Hz}$
4. The following items should be checked periodically:
  - Make sure the power supply plugs do not feel warm.
  - Power supply cords should be free of cracks and scratches.
  - Power supply plugs should be firmly plugged into outlets.

## 2.4 Installation Space

To ensure easy machine operation, replacement of consumables, and maintenance service jobs, provide the following space for the installation of the machine.

Allow the enough space around the louver to keep the good ventilation.

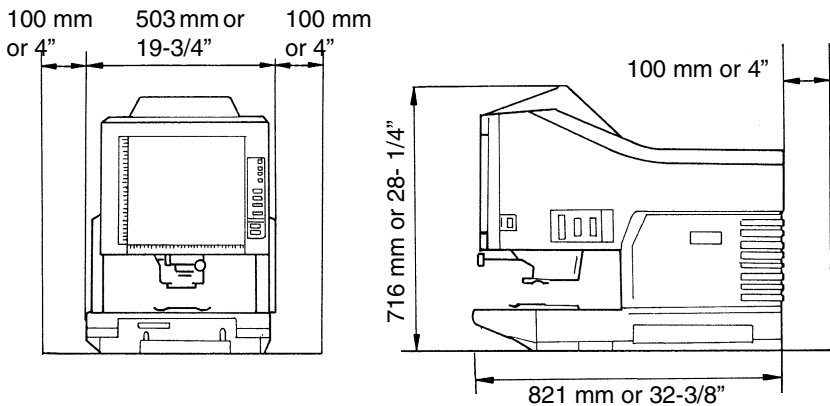



## 3 General Information

### 3.1 Specifications

#### 3.1.1 MS 6000

Specifications	
Type:	Desk-Top Type Microfilm Scanner
Type of Film:	Microfiche, Aperture Card, Jacket, Roll Films (16 mm, 35 mm), 16mm Cartridge Film both Positive and Negative
Magnification:	Single Lens..... 7.5X Zoom Lens..... 9X-16X, 13X-27X, 23X-50X
Screen Size	300 mm X 300 mm or 12" X 12" (Scanning Area)
Image Rotation	Prism Rotation Carrier Rotation (Fiche Carrier 5 only)
Resolution:	200, 300, 400, 600, 800 dpi (PC Mode) 400, 600 dpi (PR Mode: When MSP 3000 Printer is connected) 400 dpi (PR Mode: When MSP 2000 Printer is connected)
Scanning Method	Scanning/Scanning direction: CCD scanning Scanning/Feeding direction: Mirror scanning
Scanning Speed	6.5 sec./1 frame scanning 5.5 sec./Multi-frame scanning (8-1/2" X 11" or A4 Lengthwise, 400dpi, AE)
Exposure Setting	2 way Settings: Automatic Control & Manual Control
N-P/P-P Select	Auto/Manual Select
Scanning Mode	Text/Photo/Fine
Output Scale:	PC Mode: Binary, Grayscale (Option) PR Mode: Binary
PC Interface:	SCSI-2 (Option)
Auto Edit Function	Auto Frame Masking, Auto Centering, Auto Skew Correction, Fit, Trimming, Masking, Electrical Zoom, Electrical Image Rotation
Light Source	Halogen Lamp (20V 150W DDL Type)
Power Requirement	120VAC (60Hz), 220/240VAC (50-60Hz)
Power Consumption	Less than 350W (with all options)
B.T.U (British Thermal Unit)	900 BTU (Reader Mode) 850 BTU (Scan Mode)
Acoustic noise	53 dB or less (Scanning) 50 dB or less (Reader)
Dimensions	503 mm (W) x 821 mm (D) x 716 mm (H) or 19-3/4" (W) x 32-3/8" (D) x 28-1/4" (H)
Weight	39 Kg or 86 lbs

<b>Specifications</b>	
Standard Accessories	Power Cord, Printer Cable, Operator's Manual
Options:	Lenses, Prism Unit, Fiche Carrier 5, Universal Carrier UC-2, Roll Film Carrier 9B, Roll Film Carrier 15A/15M, Roll Film Carrier 21, MARS Controller 4, MARS Mini Controller 2, Manual Frame Masking Kit, Counter Kit, Foot Switch Kit, PC Interface Kit, Grayscale Memory Board

### 3.1.2 MS 6000 & MSP3000 Printer System

Specifications	
Type:	Microfilm Scanner Printer System
Printing Method:	Laser Electrostatic
Resolution:	400, 600 dpi
Print Size:	8-1/2" × 11" (or A4) Crosswise, 11" × 17" (or A3) Lengthwise 8-1/2" × 11" (or A4) Lengthwise, 8-1/2" × 14" (or B4) Lengthwise
Print Speed:	20 sheets per minute (8-1/2" × 11" or A4: Crosswise)
First Print Time:	13 seconds (8-1/2" × 11" or A4: Crosswise)
Warm-up Time:	Less than 70 seconds
Multiple Printing:	1-19 sheets (LED countdown identification)
Paper Supply:	Automatic Feeding System Paper Feeding Tray (250 sheets max.) Paper Cassette 1 (250 sheets max.) Paper Cassette 2 (250 sheets max.): Option
Power Consumption:	Less than 1100W (Scanner: 350W, Printer: 750W)
Printer's Dimensions	561mm (W) x 521mm(D) x 409 mm (H) or 22" (W) x 20-1/2" (D) x 16" (H)
Printer's Weight	28 Kg or 61-3/4 lbs (including Imaging Cartridge)
Printer's Option:	Second Paper Cassette Unit

### 3.1.3 MS 6000 & MSP2000 Printer System

Specifications	
Type:	Microfilm Scanner Printer System
Printing Method:	Laser Electrostatic
Resolution:	400 dpi
Print Size:	8-1/2" × 11" (or A4)
Print Speed:	8 sheets per minute (8-1/2" × 11" or A4)
First Print Time:	19 seconds (8-1/2" × 11" or A4)
Warm-up Time:	Less than 20 seconds
Multiple Printing:	1-19 sheets (LED countdown identification)
Paper Supply:	Automatic Feeding System Multipurpose tray (150 sheets max.)
Power Consumption:	Less than 930W (Scanner: 350W, Printer: 580W)
Printer's Dimensions	394 mm(W) x 446 mm(D) x 328 mm(H) or 15-1/2"(W) x 17-1/2"(D) x 13"(H)
Printer's Weight	17 lbs. (7.8kg) <Including Toner/Drum Cartridge>
Printer's Option:	Face-Up Tray

### 3.2 System Configuration

Scanner

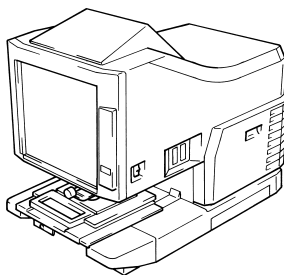

Projection Lens

-Single Lens

- Zoom Lens



7.5X



9-16X



13-27X



23-50X

Film Carrier

FC-5

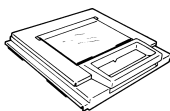

RFC-9B

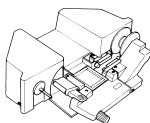

UC-2

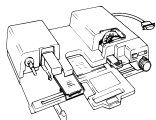

RFC-21

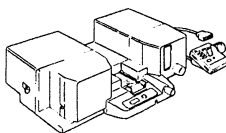

RFC-15A

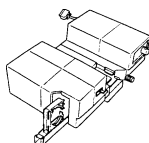

RFC-15M

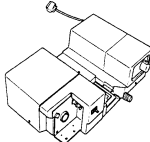

Auto Retrieval Controller

MARS C-4



MARS MINI 2



### 3.3 Connection Mode

This Scanner is available in the following configurations.

#### 3.3.1 PR Mode (Scanner + Printer)

The Scanner is connected to a dedicated printer, allowing scanned images to be printed out directly.

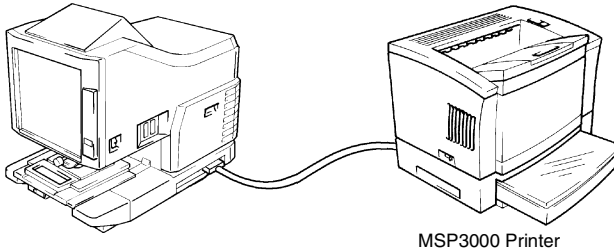

MSP3000 Printer

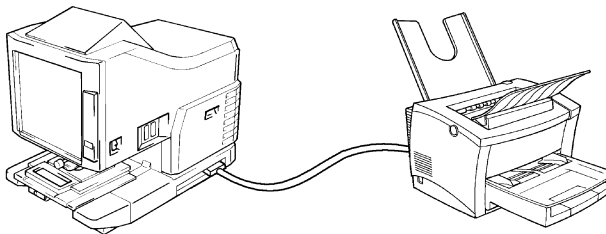

MSP2000 Printer

Each scanner is designed exclusively for use with its respective Printer.

#### 3.3.2 PC Mode (Scanner + Personal Computer)

The Scanner is connected to a personal computer and the scanned images can be uploaded to the computer. An optional PC interface kit required for connection to a personal computer.

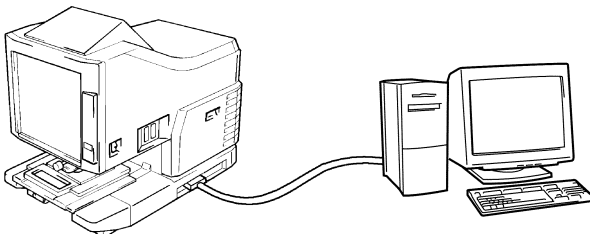

Connection to a personal computer and printer can be switched using Control Panel.

### 3.4 Parts Identification

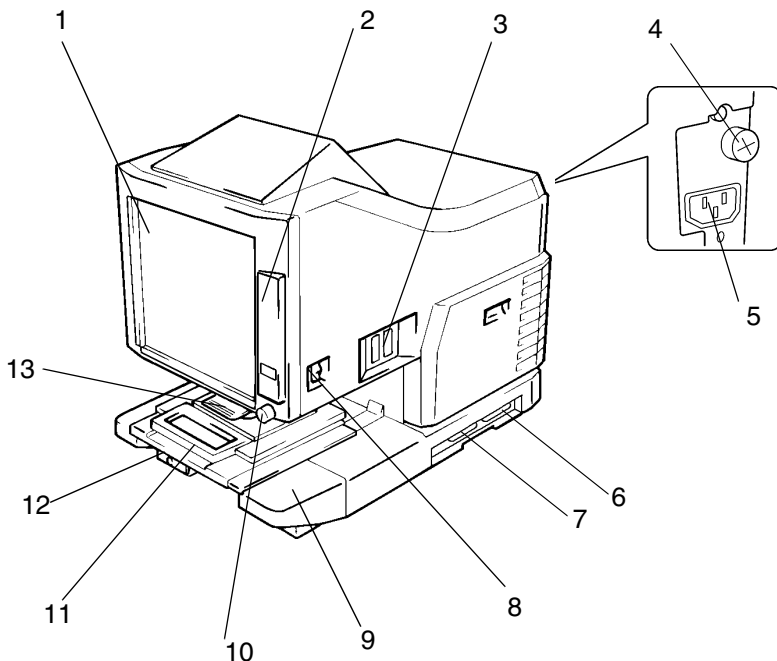

1. Screen
2. Control Panel
3. Option Interface Connector (option)
4. Fuse Holder
5. Power Cord Socket
6. Printer Connector
7. SCSI Connector
8. Power Switch
9. Projection Unit
10. Image Rotation Knob
11. Fiche Carrier 5 (option)
12. Brightness Select Lever
13. Projection Lens (option)

### 3.5 Component Layout

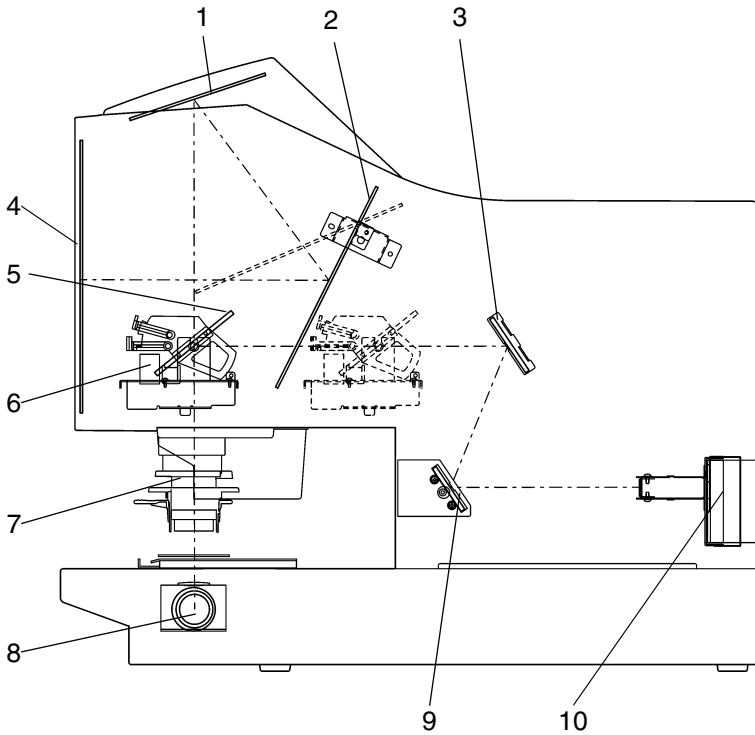

- |                           |                         |
|---------------------------|-------------------------|
| 1. 1st Reader Path Mirror | 6. Scan Table           |
| 2. 2nd Reader Path Mirror | 7. Projection Lens      |
| 3. 2nd Scan Path Mirror   | 8. Projection Lamp      |
| 4. Screen                 | 9. 3rd Scan Path Mirror |
| 5. 1st Scan Path Mirror   | 10. CCD Assy            |

### 3.6 Electrical Components Layout

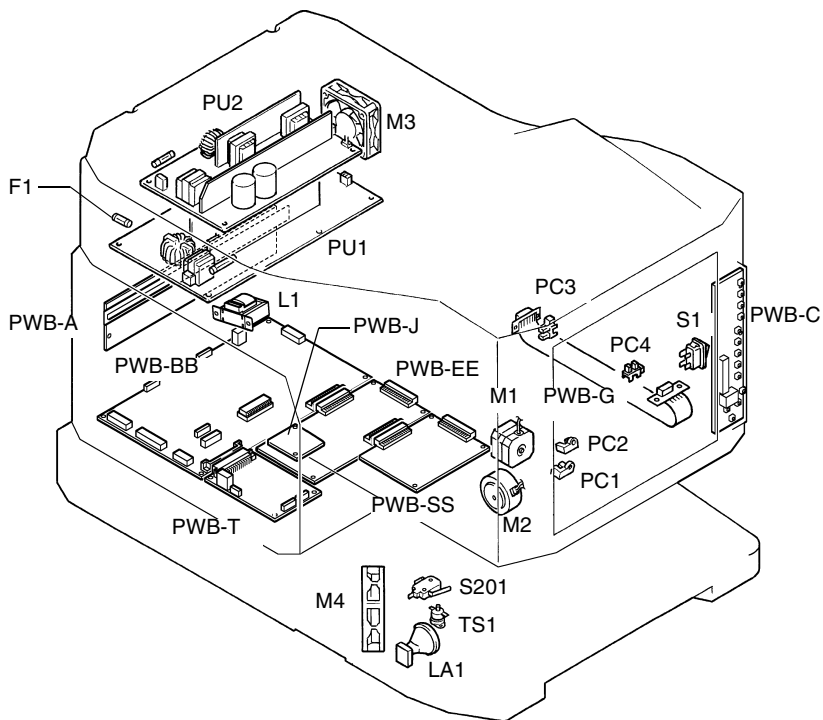



Symbol	Name
F1	Fuse
L1	Filter Coil
LA1	Projection Lamp
M1	Scan Motor
M2	Scan Table Motor
M3	Power Unit Cooling Fan Motor
M4	Projection Lamp Cooling Fan Motor
PC1	Image Leading-Edge Position Sensor
PC2	Scan Mirror Position Sensor
PC3	Reader Position Sensor
PC4	Scan Position Sensor
PU1	Main Power Unit
PU2	Projection Lamp Regulator
PWB-A	CCD Board
PWB-BB	Main Control Board
PWB-C	Control Panel Board
PWB-EE	Printer I/F Board
PWB-G	Scan Table Connecting Board
PWB-J	Grayscale Memory Board
PWB-SS	PC I/F Board
PWB-T	Motor Drive Board
S1	Power Switch
S201	Interlock Switch
TS1	Thermostat

\*PWB-J, PWB-SS : Option

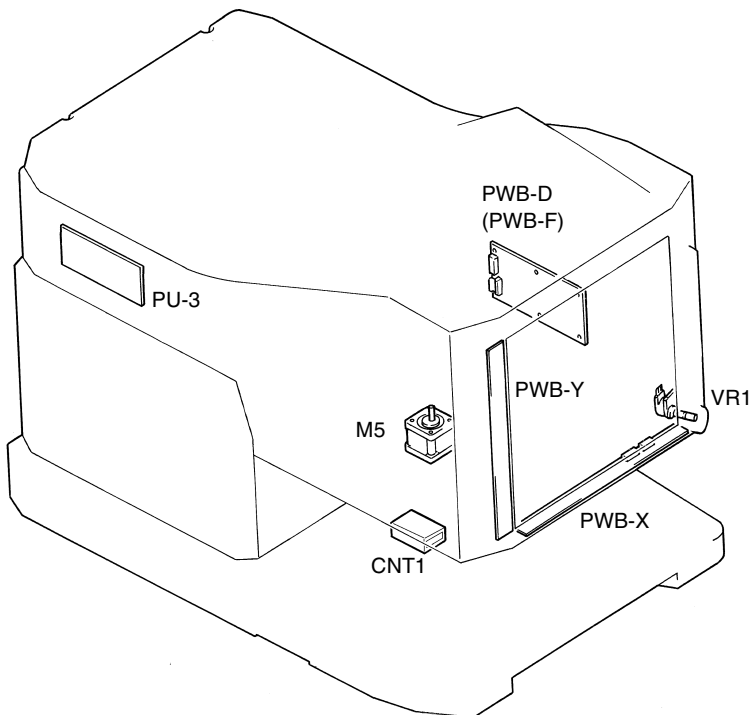

Symbol	Name
CNT1	Total Counter
M5	Auto Image Rotation Motor
PU3	Option Power Unit (for RFC-21)
PWB-D	Option I/F Board (for RFC-15A/M, UC-2, MARS)
PWB-F	Option I/F Board (for RFC-21, UC-2, MARS)
PWB-X	Manual Masking Board
PWB-Y	Manual Masking Board
VR1	Auto Image Rotation Volume

\*CNT1, PU3, PWB-D, PWB-F, PWB-X, PWB-Y : Option

### 3.7 Electrical Parts Function

Symbol	Name	Function
CNT1	Total Counter	Counts the number of prints.
F1	Fuse	Power Fuse 100/120V Area: 250V, 10A 220-240V Area: 250V, 6.3A
L1	Filter Coil	Power-supply noise filter
LA1	Projection Lamp	The source of the light for projecting the film image
M1	Scan Motor	The motor which rotate the 1st scanning mirror when carrying out scan of the film image to CCD.
M2	Scan Table Motor	The motor for moving a scanning table to a reader position and a scanning position.
M3	Power Unit Cooling Fan Motor	Exhausts the heated air surrounding the Power Unit out of the machine.
M4	Projection Lamp Cooling Fan Motor	Exhausts the heated air surrounding the Projection Lamp out of the machine.
M5	Auto Image Rotation Motor	The motor which rotate a prism.
PC1	Image Leading-Edge Position Sensor	Detects the slit on the Scan Mirror mounting plate. Leading-edge detect :L
PC2	Scan Mirror Position Sensor	Detects the home position of the Scan Mirror. Scan Mirror home position detect :L
PC3	Reader Position Sensor	Detects the reader position of the Scan Table. Reader position detect :L
PC4	Scan Position Sensor	Detects the scan position of the Scan Table. Scan position detect :L
PU1	Main Power Unit	Converts the power voltage from AC voltage into DC voltage.
PU2	Projection Lamp Regulator	Converts the power voltage from AC voltage into DC voltage and supplies that to LA1.
PU3	Option Power Unit (for RFC-21)	Converts the power voltage from AC voltage into DC voltage (DC-24V) and supplies that to optional RFC21.
PWB-A	CCD Board	The CCD reads the film image.
PWB-BB	Main Control Board	Controls all machine operation.
PWB-C	Control Panel Board	The keys and LEDs which make operation of the machine possible are included.
PWB-D	Option I/F Board	The Interface board which connects an option (RFC, MARS).
PWB-EE	Printer I/F Board	Communicates with the Main Control Board and printer.
PWB-F	Option I/F Board	Communicates with the Main Control Board and option (MARS, RFC).

Symbol	Name	Function
PWB-G	Scan Table Connecting Board	Connects the Scan Table Section and Main Harness of the machine.
PWB-J	Grayscale Memory Board	PC Mode: Memory used when image is read with Grayscale. PR Mode: Memory used when image is read by print reserve function.
PWB-SS	PC I/F Board	Communicates with the Personal Computer and machine.
PWB-T	Motor Drive Board	The substrate which controls the motors.
PWB-X	Manual Masking Board (Horizontal)	The substrate which specifies the Masking position of the horizontal direction.
PWB-Y	Manual Masking Board (Vertical)	The substrate which specifies the Masking position of the vertical direction.
S1	Power Switch	Turns ON or OFF the machine.
S201	Interlock Switch	Detects the removing or installing of the Projection Unit.
TS1	Thermostat	Cuts off the current to the Projection Lamp (LA1) when it detects overheating. (Rating: 195°C)
VR1	Auto Image Rotation Volume	The Volume which adjusts the rotation direction and the speed of an auto image rotation motor (M5).

CNT1, PU3, PWB-D, PWB-F, PWB-J, PWB-SS, PWB-X, PWB-Y: Option

## 3.8 Connectors Layout

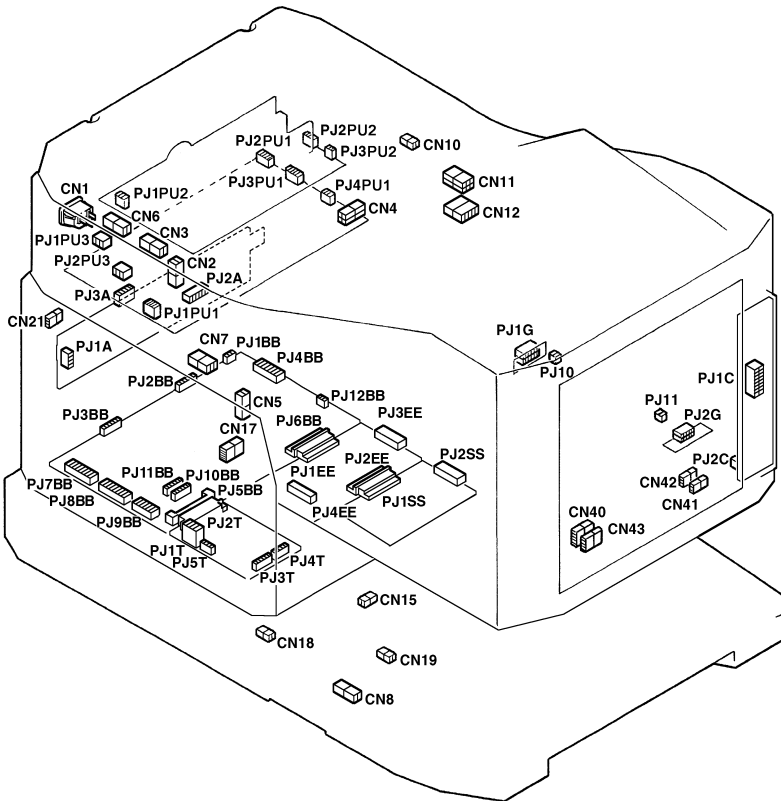

CN1 3P	CN42 3P	PJ12BB 4P	PJ1EE 60P
CN2 2P	CN43 6P	PJ1C 28P	PJ2EE 80P
CN3 2P	PJ10 3P	PJ2C 3P	PJ3EE 50P
CN4 4P	PJ11 3P	PJ1T 4P	PJ4EE 40P
CN5 2P	PJ1A 4P	PJ2T 32P	PJ1G 20P
CN6 2P	PJ2A 20P	PJ3T 9P	PJ2G 20P
CN7 3P	PJ3A 10P	PJ4T 8T	PJ1SS 80P
CN8 2P	PJ1BB 3P	PJ5T 6T	PJ2SS 50P
CN10 3P	PJ2BB 20P	PJ1PU1 3P	
CN11 6P	PJ3BB 10P	PJ2PU1 4P	
CN12 12P	PJ4BB 24P	PJ3PU1 6P	
CN15 3P	PJ5BB 32P	PJ4PU1 3P	
CN17 5P	PJ6BB 60P	PJ1PU2 3P	
CN18 3P	PJ7BB 26P	PJ2PU2 4P	
CN19 2P	PJ8BB 30P	PJ3PU2 2P	
CN21 4P	PJ9BB 18P	PJ1PU3 5P	
CN40 6P	PJ10BB 7P	PJ1PU3 6P	
CN41 3P	PJ11BB 11P	PJ2PU3 4P	

\*PJ9BB, PJ12BB: Not Used

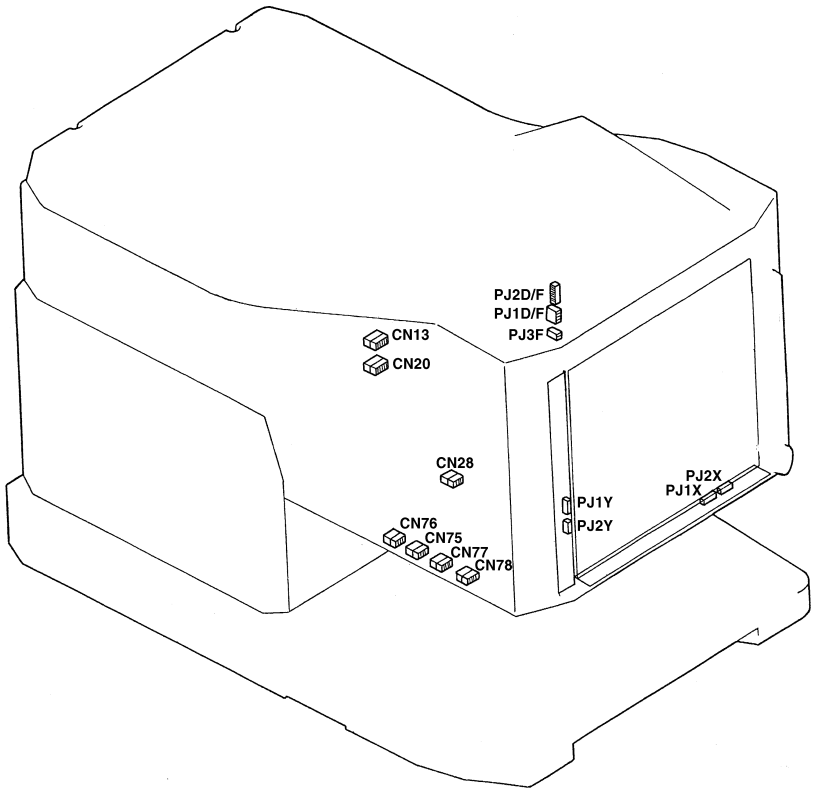

CN13 9P  
CN20 11P  
CN28 6P  
CN75 8P  
CN76 9P  
CN77 8P  
CN78 9P  
PJ1D/F 5P  
PJ2D/F 13P

PJ3F 2P  
PJ1X 8P  
PJ2X 9P  
PJ1Y 8P  
PJ2Y 9P

## 3.9 Electrical Service Parts on P.W.Boards

### NOTE

Do not touch the electric parts which has not indicated of this section.

### 3.9.1 Main Control Board (PWB-BB)

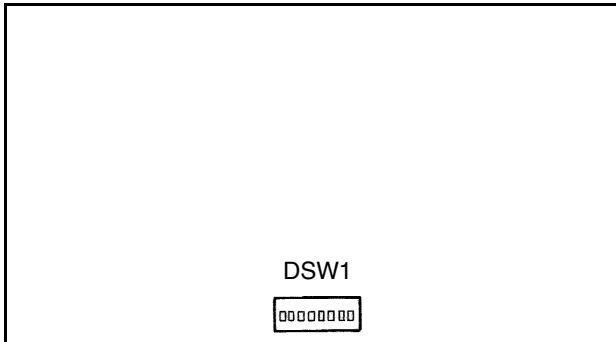

DSW1...For Factory Use Only  
(Normally all switches are OFF position.)  
\*Do not change to ON position.

### 3.9.2 I/F Board (PWB-EE)

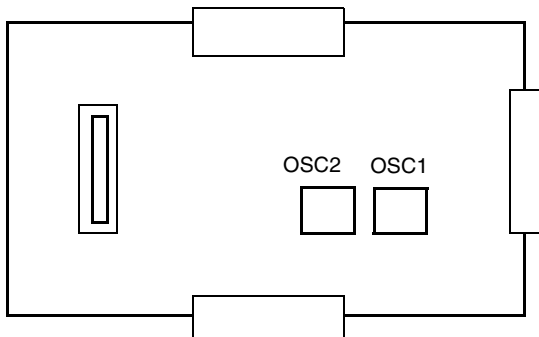

OSC1 ...Oscillator (42.3158MHz): For 400dpi Printer  
OSC2 ...Oscillator (95.2106MHz): For 600dpi Printer

### 3.9.3 I/F Board (PWB-SS)

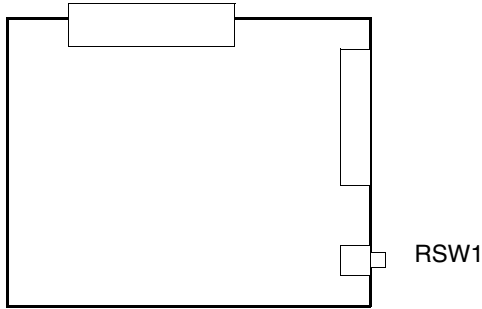

RSW1..For SCSI ID setting

### 3.9.4 Main Power Unit (PU1)

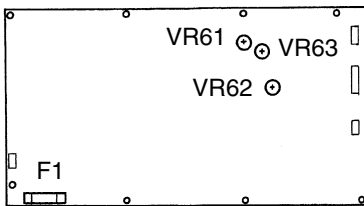

VR61: For Factory use \*Do Not Touch  
 VR62: For Factory use \*Do Not Touch  
 VR63: For Factory use \*Do Not Touch

F1: Fuse  
 AC250V 12A (100/120V area)  
 AC250V 6.3A (220/240V area)

### 3.9.5 Projection Lamp Regulator (PU2)

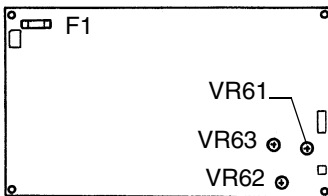

VR61: Projection Lamp voltage adjustment  
 VR62: For Factory use \*Do Not Touch  
 VR63: For Factory use \*Do Not Touch

F1: Fuse  
 AC125V 5A (100/120V area)  
 AC250V 5A (220/240V area)

### 3.9.6 Optional Power Unit (PU3)

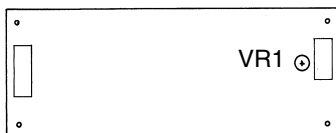

VR1: For Factory use \*Do Not Touch



### 3.10 Explanation of Control Panel

#### 3.10.1 Control Panel (Basic)

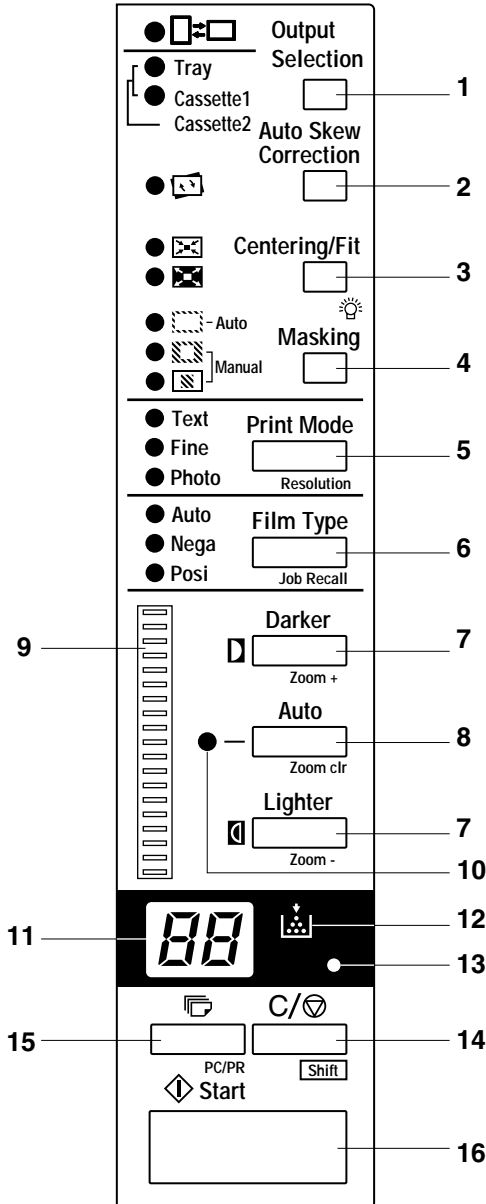

1. Size Selection Key: Select the paper feeding source according to the format of the film image that is being reflected in the screen.



when this lamp is lit:

A 90 degree image rotation is performed during printing.

The image on the screen will be rotated 90 degrees. Consequently, the screen image will be oriented horizontally on paper that is positioned lengthwise, and vertically on paper that is positioned crosswise.

when this lamp is blink:

The Auto Film Format Select Print function is available when Letter (or A4) size paper is placed in both lengthwise and crosswise positions in the paper feeding tray and paper feeding cassette. Paper that best suits the format of the image on the screen will be used for printing.

Tray: Prints the film image on paper fed from the print tray.

Cassette1: Prints the film image on paper fed from the cassette 1.

Cassette2: Prints the film image on paper fed from the cassette 2. (when the Tray and Cassette1 indicators are both lit)

2. Auto Skew Correction Key:

This key is used to turn the Auto Skew Correction function ON or OFF. When this function is applied, the Auto Skew Correction indicator will turn on and the system will correct any skew of the image during printing.

\* After printing, the skew can be reset or retained.

3. Centering/Fit Key: When this key is pressed, the setting rotates from OFF to the Centering and Fit functions.  
When Auto Masking, Trimming, or Masking are set to off, Auto Masking will automatically be enabled when Centering is selected.



**Centering:**

Places a screen image that had been searched using Auto masking or an image that has been trimmed in the center of the page.



**Fit:**

Enlarges a screen image that had been searched using Auto masking or an image that has been trimmed to fit the page.

\*When Masking  is selected or when the Scanner is connected to the PC, this mode cannot be used.

4. **Masking Key:** When pressed, this key rotates from OFF to the Auto, Trimming or Masking functions. Each time this key is pressed, selection is switched in order of "OFF → Auto Masking → Manual Trimming → Manual Masking → OFF."

**Auto Masking:**

The Auto Masking function will omit the frame (non-image area) of a printed film image.

- The previous Centering/Fit setting is applied whenever ON is selected from the OFF state.
- If OFF is selected from the ON state, Centering/Fit is disabled.
- \* Auto Masking is not applicable with the Masking or Trimming settings.

**Trimming:**

When ON is selected, the image is printed (scanned) with the non-image area (frame) automatically masked.

**Masking:**

Prints only the image outside of the area that is defined on the Screen.

- If Trimming is selected from the OFF state, the previously entered settings for Centering/Fit and Manual Masking are applied.
- From Trimming, when Masking is selected, the Centering/Fit setting is disabled and the previous settings for the Masking area are applied.
- The manual masking area will be cancelled whenever OFF is selected from the Masking state.
- \* Neither Trimming nor Masking are available through the Auto Masking function.
- \* Trimming and Masking cannot be set when the Scanner is connected to the PC.

5. **Print Mode Key:** Allows you to fine tune the image quality of the print according to the original being used. Rotate between Text, Fine and Photo with every press of this key.

**Text:** For use with text images.

**Fine:** For use with lower grades of film.

**Photo:** For use with photo images.

6. **Film Type Key:** Rotates between Auto, Nega, and Posi each time the key is pressed.
- Auto:** The scanner automatically determines between the film type options of negative or positive for print production.
- Nega:** Select when using negative film. Dark and light values of the print will be reversed.
- Posi:** Select when using positive film. Dark and light values of the print will be consistent with the image on film.
7. **Exposure Adjustment Keys:** Use this key to adjust the image density of the image to be printed during the Auto or Manual Exposure mode. The Darker key supports darker image density and the Lighter key supports lighter image density.
8. **Exposure Mode Key:** Press to select between the Auto or Manual Exposure mode.
9. **Exposure Display:** Indicates the current density level of the printed image.
10. **Exposure Mode Indicator:** Auto Exposure mode is indicated when the green Auto light is on. The green Auto light turns off when the Scanner is in the Manual Exposure mode.

11. Multi-Print Display: Shows the number of prints set to be made. Also displays corresponding codes in the event of a malfunction or paper misfeed. The blinking number in this display indicates the Scanner in operation.

Display	Contents	Unit
L2	Projection Lamp malfunction	Scanner
C1	Scan Unit Drive malfunction	
C2	Scan Mirror Drive malfunction	
C3	Shading Correction malfunction	
C4	Cooling Fan Motor malfunction	
C6	Fusing malfunction	Printer
C7	Laser Diode malfunction	
C8	Polygon Motor malfunction	
C9	Main Motor malfunction	
CA	Cooling Fan Motor malfunction	
Cb	Communication Error	Scanner Printer
CL	Printer Clock malfunction	Scanner
PE	Paper Empty	Printer
P0	Paper Size Error	
P1	Paper Misfeed (Paper Take-up Section)	
P2	Paper Misfeed (Paper Transport Section)	
P3	Paper Misfeed (Fusing Section)	
E1	Printer Power OFF or Cable disconnect	
E2	Top Cover Open	

12. Add Toner Indicator: Blinks when the Imaging Cartridge or Toner Cartridge of the Printer is running out of toner and lights up when the cartridge has completely run out of toner.

13. **Memory Input Key:** To store one of the following functions into the memory of the Scanner, first set one of the functions on Control Panel and then press this button with the head of a pen or other device. The next time the scanner is turned ON, that function will appear as a default setting until a new one is entered. (Maximum three kind of setting can be memorized.)
- 1) Film Type
  - 2) Print mode
  - 3) Output Selection
  - 4) Print image density
  - 5) Exposure mode
  - 6) Centering or Fit
  - 7) Masking
  - 8) Auto Skew Correction
  - 9) Horizontal Area setting
  - 10) Vertical Area setting
  - 11) Electrical Zoom
  - 12) Resolution
- If you do not press the pinhole for at least 60 seconds after a setting has been made with the Auto Reset function set to ON, the previous setting remains valid.
14. **Clear/Stop Key:** Press to clear the setting on the Multi-Print Display, re-setting it to "1" or to stop a multi-print cycle.
15. **Multi-Print Keys:** This key is used to set the number of prints when printing continuous, multiple pages. The value of this setting increases by one (1, 2, 3...) with every push of the key. (Maximum 19)  
\* PR mode only.
16. **Start Key:** Press to make a print (scan) of the image shown on the Screen.

### 3.10.2 Control Panel (Shift Function)

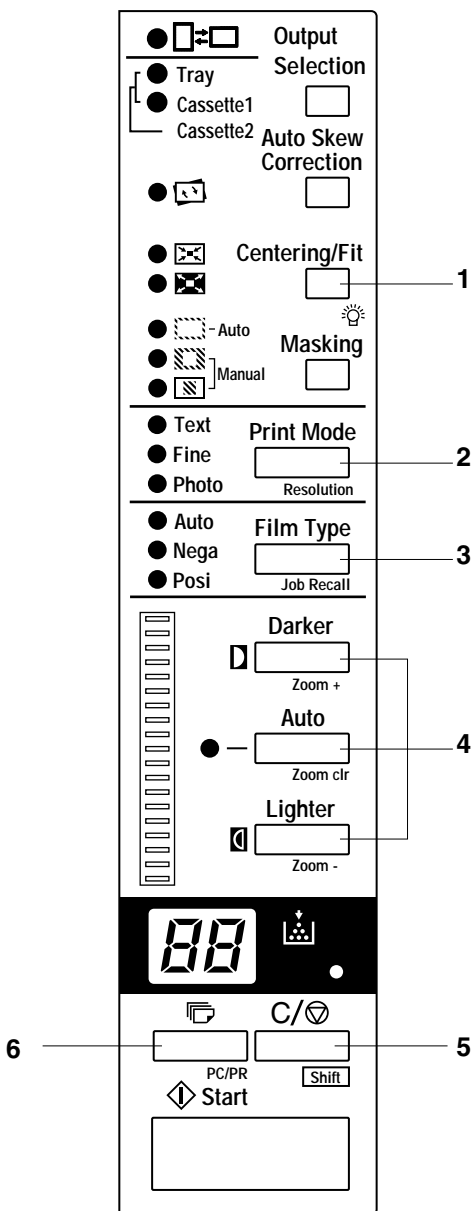



1. Lamp Illuminance Key: When this key is pressed together with the Shift Key, the illumination of the screen is adjusted. When this key is continuously pressed, the screen is gradually darkened until it is turned OFF. When any key is pressed then, the illumination returns to the maximum level.
2. Resolution Key: When this key is pressed together with the Shift Key, the resolution of the Scanner is set.  
When the Scanner is connected to the Printer: 4H and 6H  
When the Scanner is connected to the PC: 2H, 3H, 4H, 6H and 8H  
\* 4H represents 400dpi and 6H represents 600dpi.
3. Job Recall Key: When this key is pressed together with the Shift Key, the program registration locations (1J, 2J and 3J) are called. Each time this key is pressed while the Shift Key is held down, the display is switched in order of 1J → 2J → 3J.
4. Zoom Key: When this key is pressed together with the Shift Key, the electrical zoom magnification is set.  
Zoom+: When this key is pressed together with the Shift Key, the magnification is increased by an increment of 0.01X (up to 2.00X).  
Zoom clr: When this key is held down together with the Shift Key for one second, the standard magnification is resumed.  
Zoom-: When this key is pressed together with the Shift Key, the magnification is decreased by a decrement of 0.01X (down to 0.50X).
5. Shift Key: Executes an expansion function when being pressed together with the intended function key.
6. PC/PR Key: When this key is pressed together with the Shift Key, the connection to the PC or to the Printer is selected.  
\*This key is not valid unless the PC interface kit (optional) is installed.

### 3.11 Image Processing

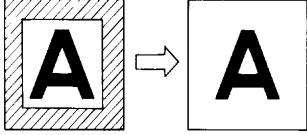
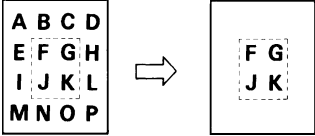
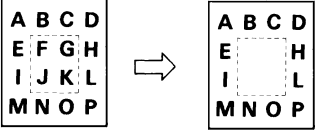
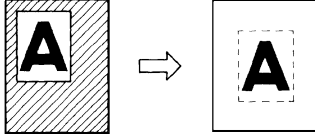
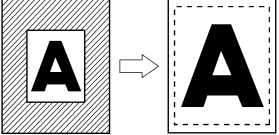
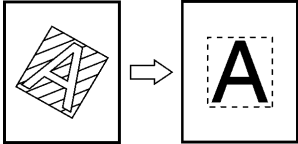
Screen Image → Print Image	Explanation
<p>Auto Masking</p> 	<p>The system masks the black bands that run along the edges of the image.</p>
<p>Trimming</p> 	<p>The system masks everything but the center of the image. The Manual Frame Masking Kit (option) is required.</p>
<p>Masking</p> 	<p>The system masks the center of the image appearing on the screen through the Manual Frame Masking Panel function. The Manual Frame Masking Kit (option) is required.</p>
<p>Centering</p> 	<p>The system generates an image that is centered on the printed page, from an image on the screen with a masked frame.</p>
<p>Fit</p> 	<p>Fit the image on the Screen onto the entire surface of the print.</p>
<p>Auto Skew Correction</p> 	<p>The machine automatically correct any skew of the image when printed.</p>

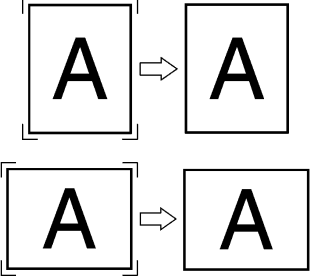
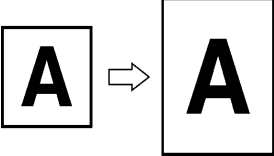
Screen Image → Print Image	Explanation
<p data-bbox="197 169 344 188">Auto Format Print</p> 	<p data-bbox="557 169 938 233">The machine automatically determines the format (portrait or landscape) of the image on the Screen and prints it as necessary.</p>
<p data-bbox="197 520 327 539">Electrical Zoom</p> 	<p data-bbox="557 520 938 625">The system magnifies the screen image according to the size of paper being used. The range of standard magnification is 1.41X for A3, 1.55X for Ledger, 1.27X for Legal and 1.22X for B4 sized paper.</p>

## 4 Mechanical and Electrical

### 4.1 Illumination Mechanism

#### 4.1.1 Overview

The Illumination Mechanism efficiently uses the light produced by the Projection Lamp to supply the most suitable amount of light for the projection of the Microfilm. This amount of light is determined by the size of the Microfilm and by the magnification ratio of the Lens selected for use.

#### 4.1.2 Projection Lamp (LA1)

A DC20V, 150W halogen Lamp is used as the light source for the reader and printer functions.

The Projection Lamp is integrated with a Lamp Reflector which is a polygon mirror to ensure even illuminance.



#### NOTE

1. Whenever the Projection Lamp Unit is removed, Make sure that the Power Switch is turned OFF.
2. Never touch the Projection Lamp immediately after it is turned OFF: be careful, it is extremely hot.
3. Do not touch with hand or dirty with grease the surfaces of the Projection Lamp and Lamp Reflector.

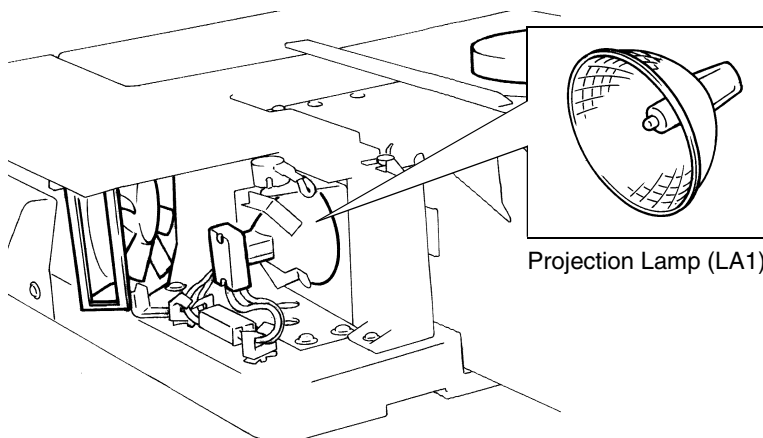

Projection Lamp (LA1)

### 4.1.3 Projection Lamp Voltage Control Circuit

The intensity of the light emitted by the Projection Lamp is adjusted to a level optimum for the image density by controlling the voltage applied to the Projection Lamp.

The exposure data optimum for film image density is determined through auto exposure data sampling made during prescan.

This exposure data is output as a Projection Lamp clock from the Main Control Board (PWB-BB) to the Projection Lamp Regulator (PU2).

The ON and OFF periods of the Projection Lamp clock extending 606  $\mu\text{sec}$ . are varied to control the Lamp voltage. The longer the OFF time, the higher the Lamp voltage.

Projection Lamp clock

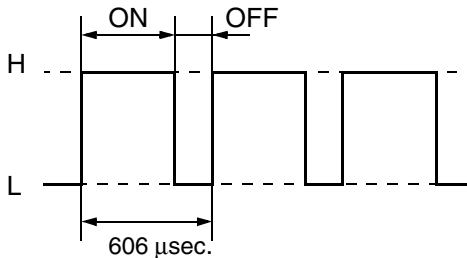

#### 4.1.4 Thermostat (TS1)

To avoid any of the troubles accompanying an excessive rise in the temperature inside the machine caused by a failure of the Cooling Fan to dissipate heat produced by the Projection Lamp, there is a Thermostat installed at the back of the Projection Lamp.

When the ambient temperature of the Projection Lamp exceeds 122°C the Heat-Sensitive Plate expands pushing up the Pusher Pin, which in turn cuts off the current to the Projection Lamp Circuit.

The Circuit is reset by pushing the Reset Pin.

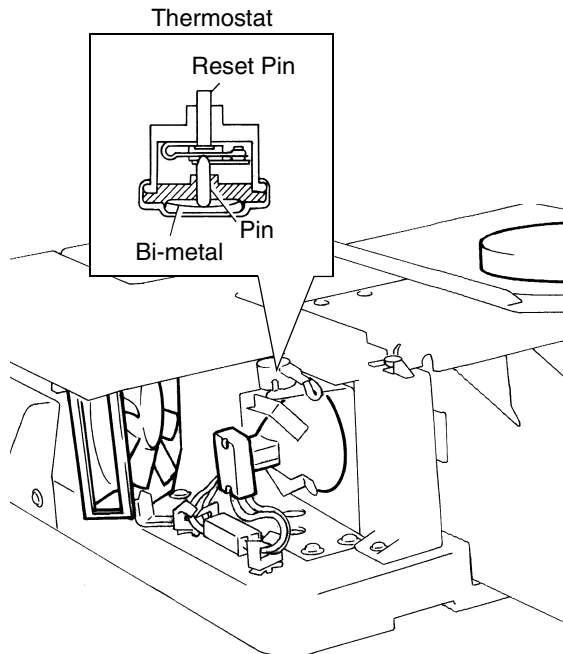

### 4.1.5 Condenser Lens

- Overview

Not only must the amount of light projected onto the Screen or CCD remain even despite changes in the microfilm or magnification ratio, but also the light coming from the Projection Lamp must be efficiently condensed. To accomplish this, the machine is equipped with two Movable Condenser Lenses: one convex and one concave.

- Movable Condenser Lenses

The Brightness Shift Lever is moved manually according to the magnification of the Projection Lens being used so that the Movable Condenser Lenses are moved to the set position. The set position is color-coded, TYPE 1 to 3, each defined by a corresponding magnification of the Projection Lens.

TYPE	Lens Magnification	Color Code
TYPE1	7.5X	Blue
TYPE1	9X-16X	Blue
TYPE2	13X-27X	Green
TYPE3	23X-50X	Yellow

- Condenser Mirror

Light from the Projection Lamp after having passed through the Movable Condenser Lenses strikes this Mirror and is reflected onto the Fresnel Lens.

- Fresnel Lens

The Fresnel Lens, which is an acrylic plate with stepped setbacks, ensures even illuminance from the Lamp.

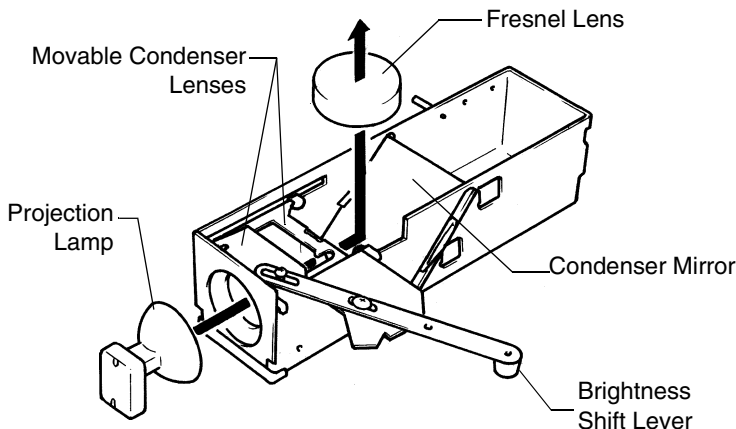

### 4.1.6 Projection Lens

The Projection Lens enlarges the image of the Microfilm and projects it onto the Screen or CCD.

Each Projection Lens comes in a unit. The Focus Ring and Zoom Ring of the Unit are used to bring the image on the Screen into focus and enlarge or reduce it, respectively.

The Prism Lens for image rotation is installed in the Prism Holder fixed to the machine.

The Projection Lens Unit is slid into position in the Lens Holder of the machine. To insert the Unit, raise the Prism Holder and, at the same time, push it into position.

When a Projection Lens Unit is installed, the Brightness Shift Lever must be moved as required according to each magnification.

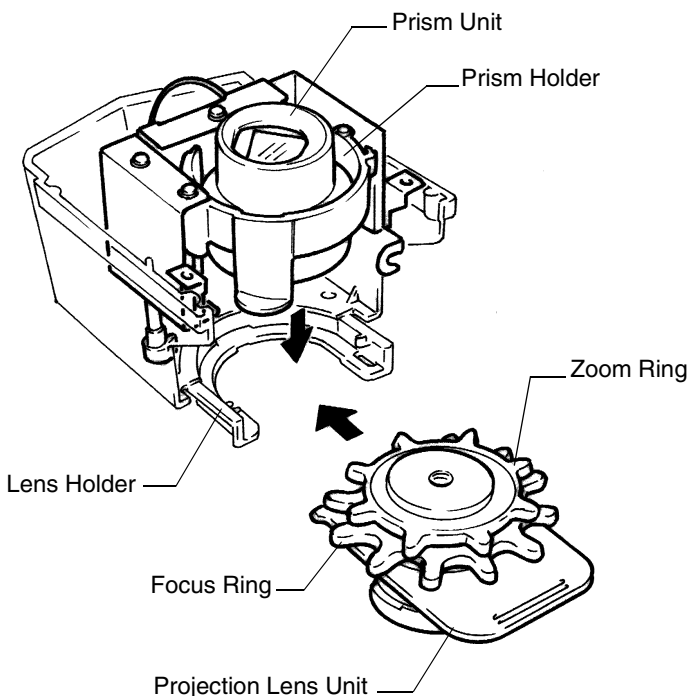



## 4.2 Image Rotation

The Prism Unit is rotated to correct any tilt of the image microfilm projected on the Screen.

### 4.2.1 Prism Rotation

The Auto Image Rotating Knob is linked to the Auto Image Rotating Variable Resistor (VR1). Turning the Knob clockwise or counterclockwise turns the Auto Image Rotating Motor (M5) whose drive is transmitted via a belt to the Prism Gear, thus turning the Prism Unit.

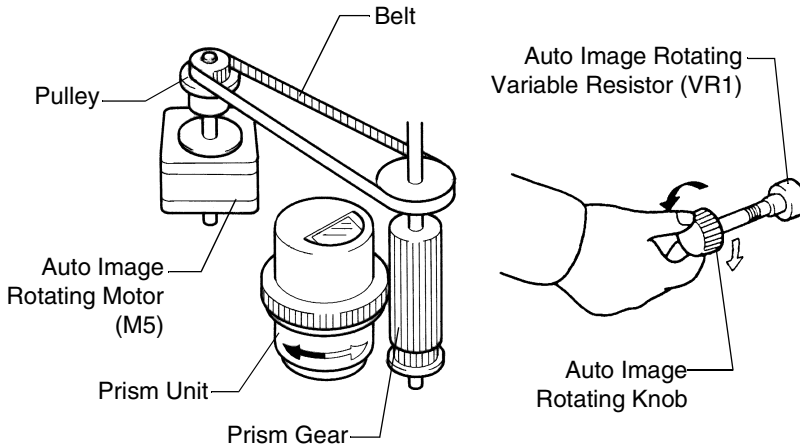

### 4.2.2 Auto Image Rotating Motor (M5) Control Circuit

When the Auto Image Rotating Knob is at the home position (center), voltage at PJ2C-2 is set at DC2.5V and the Auto Image Rotating Motor (M5) remains stationary.

PJ2C-2 reads fluctuations of the input voltages as the Auto Image Rotating Knob is turned, there by determining the direction of rotation of the Auto Image Rotating Motor.

## 4.3 Optical Section

### 4.3.1 Overview

The basic function of the Optical Section is to project an enlargement of the image on the microfilm onto the Screen when in the Reader Mode and onto the CCD when in the Scan Mode.

There is a unique light path formed in each of these modes.

The light path formed in the Reader Mode is called the Reader Path and that formed in the Scan Mode is called the Scan Path.

Each light path is formed by two Reader Path Mirrors and three Scan path Mirrors.

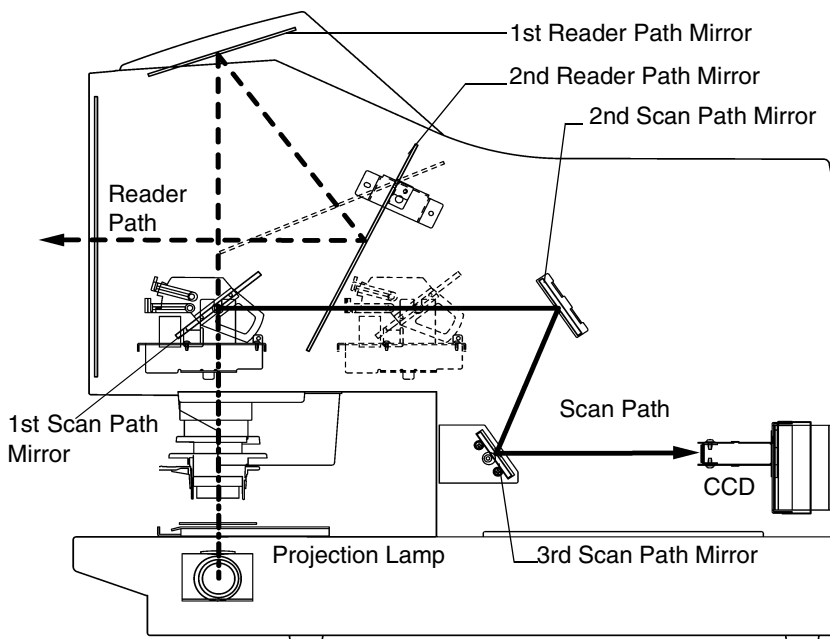

### **4.3.2 Reader Path**

The Reader Path is established when the Power Switch is turned ON and remains formed except during a scan movement.

The image on the microfilm is projected onto the entire area of the Screen by means of the two Reader Path Mirrors.

The light path between the Projection Lamp and Screen measures 1,293mm.

### **4.3.3 Scan Path**

When in the Scan mode, the 1st Scan Path Mirror moves to a position that will block the Reader Path.

It then turns to direct the film image through the four Scan Path Mirrors onto the CCD so that it can read the image data in the sub-scanning direction.

The light path between the Projection Lamp and CCD measures 1,298mm.

#### 4.3.4 Scan Table Drive Mechanism

The Reader Path is switched from the Printer Path, or vice versa, by moving the Scan Table to the respective positions.

The Scan Table is driven from the Scan Table Drive Motor (M2). The direction and speed of rotation of the Scan Table Drive Motor (M2) are controlled by the outputs from pins 3, 4, 5 and 6 ( $\phi A$ ,  $\phi B$ ,  $\overline{\phi A}$ , and  $\overline{\phi B}$ ) of PJ5T on the Motor Drive Board (PWB-T).

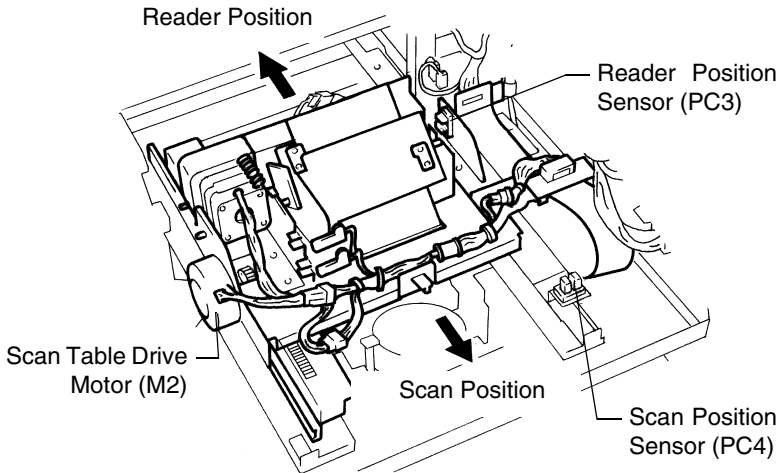

To switch from the Reader Path to the Printer Path, the Scan Table Drive Motor M3 is energized there by moving the Scan Table toward the Printer Position.

The Scan Table at the Reader Position is detected by the Reader Position Sensor (PC3) and that at the Printer Position is detected by the Scan Position Sensor (PC4).

It takes less than 1.3 sec. for the Scan Table to move from the Reader to Printer Position.

### 4.3.5 Scan Mirror Motion Control

The motion of the Scan Mirror is controlled by the Scan Lever and Shaft as the Shaft is driven by the Scanning Motor (M1).

The Scan Mirror scans the image of the microfilm at a speed  $1/631.6$  of the Scanning Motor (M1).

Once the prescan motion is initiated, the leading edge of the image is synchronized with that of the paper, and the completion of the scan motion is detected, by the Scan Start Position Sensor (PC1) which are activated and deactivated by the cutouts in the light blocking Lever.

Scan Mirror first makes a prescan motion for reading the data before making the scan motion.

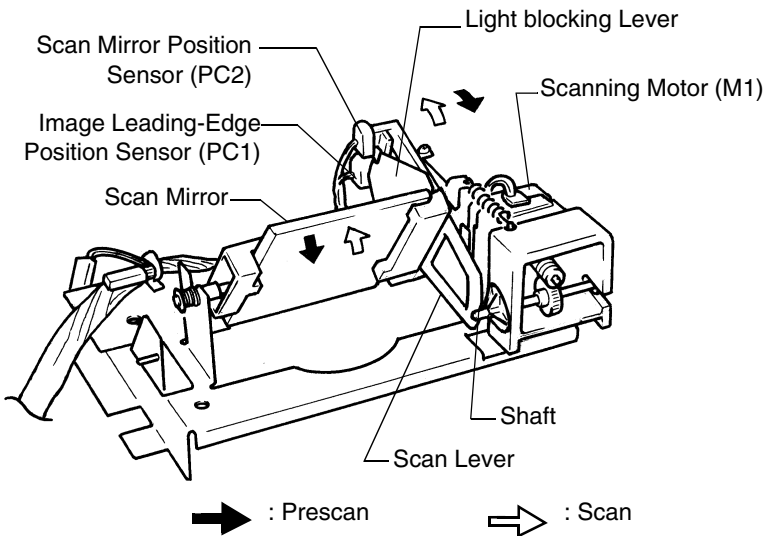

The Image Leading-Edge Position Sensor (PC1) and Scan Mirror Position Sensor (PC2) detect the cutouts in the light blocking lever.

The starting position for the prescan or scan motion is determined by particular states of these sensors, blocked (activated) or unblocked (deactivated), as detailed below.

Scan Motion	PC1	PC2
Prescan	ON (blocked)	OFF (unblocked)
Scan	ON (blocked)	ON (blocked)

### 4.3.6 Mirror Scan Motor (M1) Control Circuit

Drive of the Scanning Motor (M1) is controlled by the signals which are input to the Motor Driver Board (PWB-T) from the Main Control Board (PWB-BB).

These signals determine the direction (forward or backward) and speed of rotation of the Scanning Motor when the Scan Mirror makes a prescan and scan motion.

These signals cause the Scanning Motor drive pulses to be output from the pins (A, B,  $\bar{A}$ ,  $\bar{B}$ ) of the Motor Driver Board (PWB-T), which turns the Scanning Motor (M1).

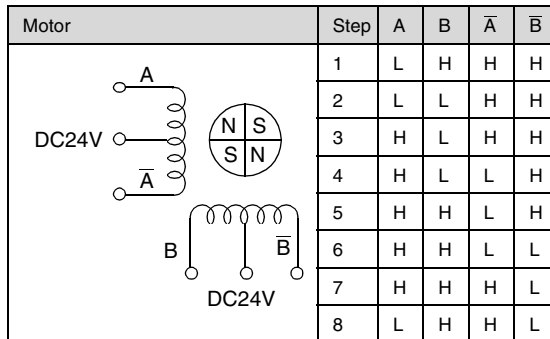

Motor	Step	Speed (Full Size)
Scan(800dpi)	1→2→3→4→→5→6→7→8→1→.....	82.5mm/sec.
Scan(600dpi)	1→2→3→4→→5→6→7→8→1→.....	110mm/sec.
Scan(400dpi)	1→2→3→4→→5→6→7→8→1→.....	165 mm/sec.
Scan(300dpi)	1→2→3→4→→5→6→7→8→1→.....	220 mm/sec.
Scan(200dpi)	2→4→6→8→2→.....	330 mm/sec.
Prescan	8→6→4→2→8→.....	330 mm/sec.

## 4.4 CCD Section

There are five 960-pixel CCD sensor chips arranged in a zigzag as illustrated below.

The total number of pixels that can be read is 4,800 with a resolution of 400dpi.

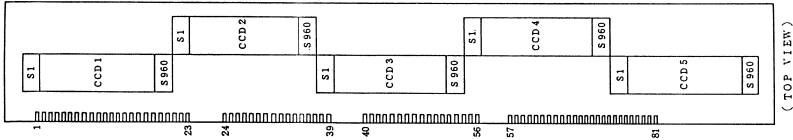

Reading With: 304.8 mm or more

Pixel Size: 63.5  $\mu\text{m}$  x 63.5  $\mu\text{m}$

## 4.5 Image Bus

The image data read by the CCD goes through analog-to-digital conversion before being output.

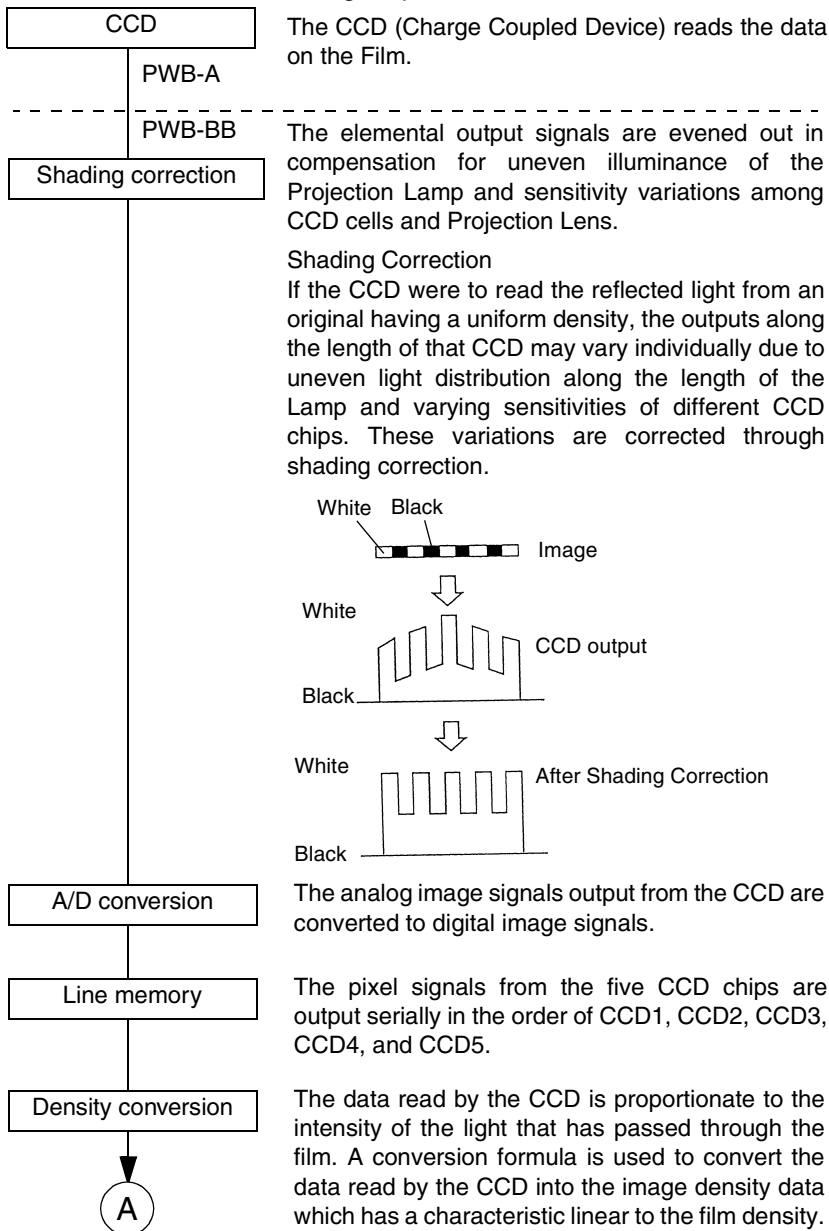



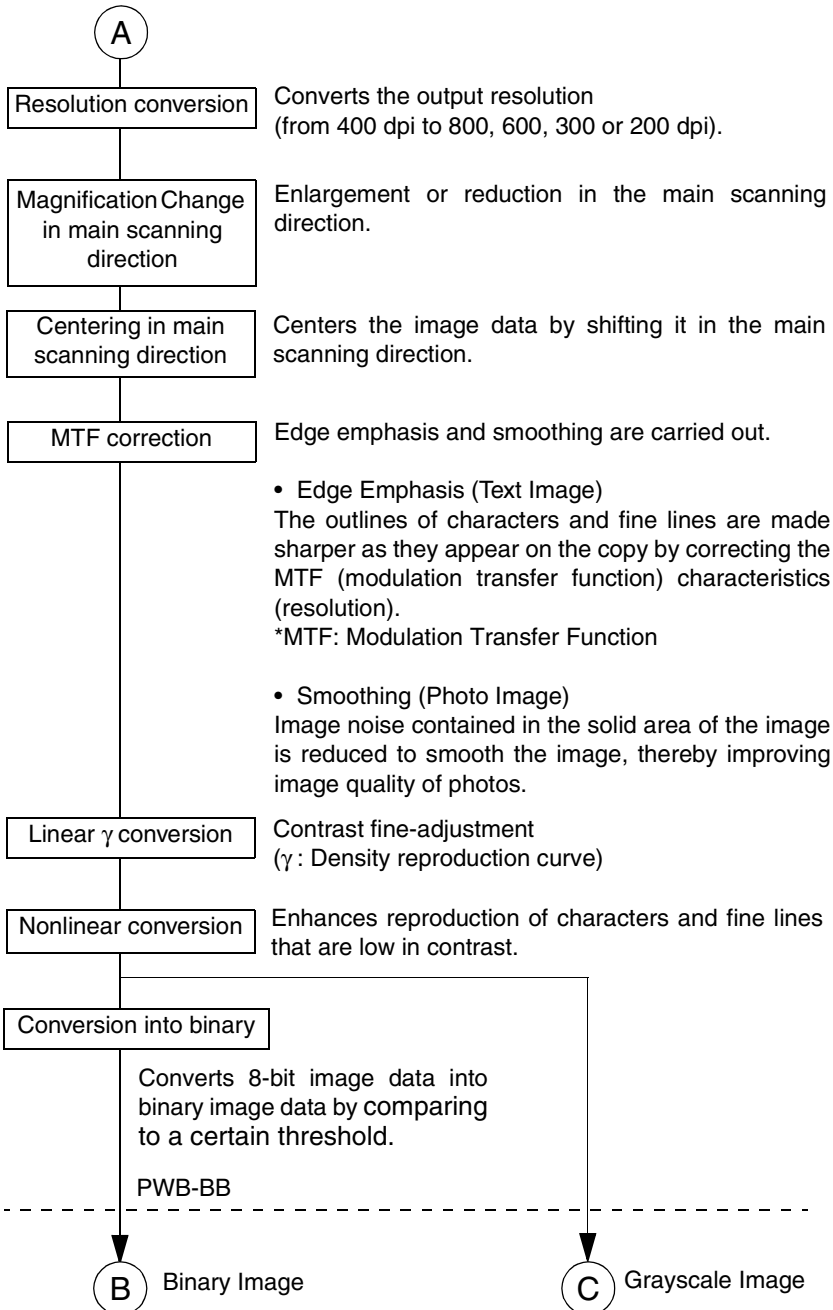

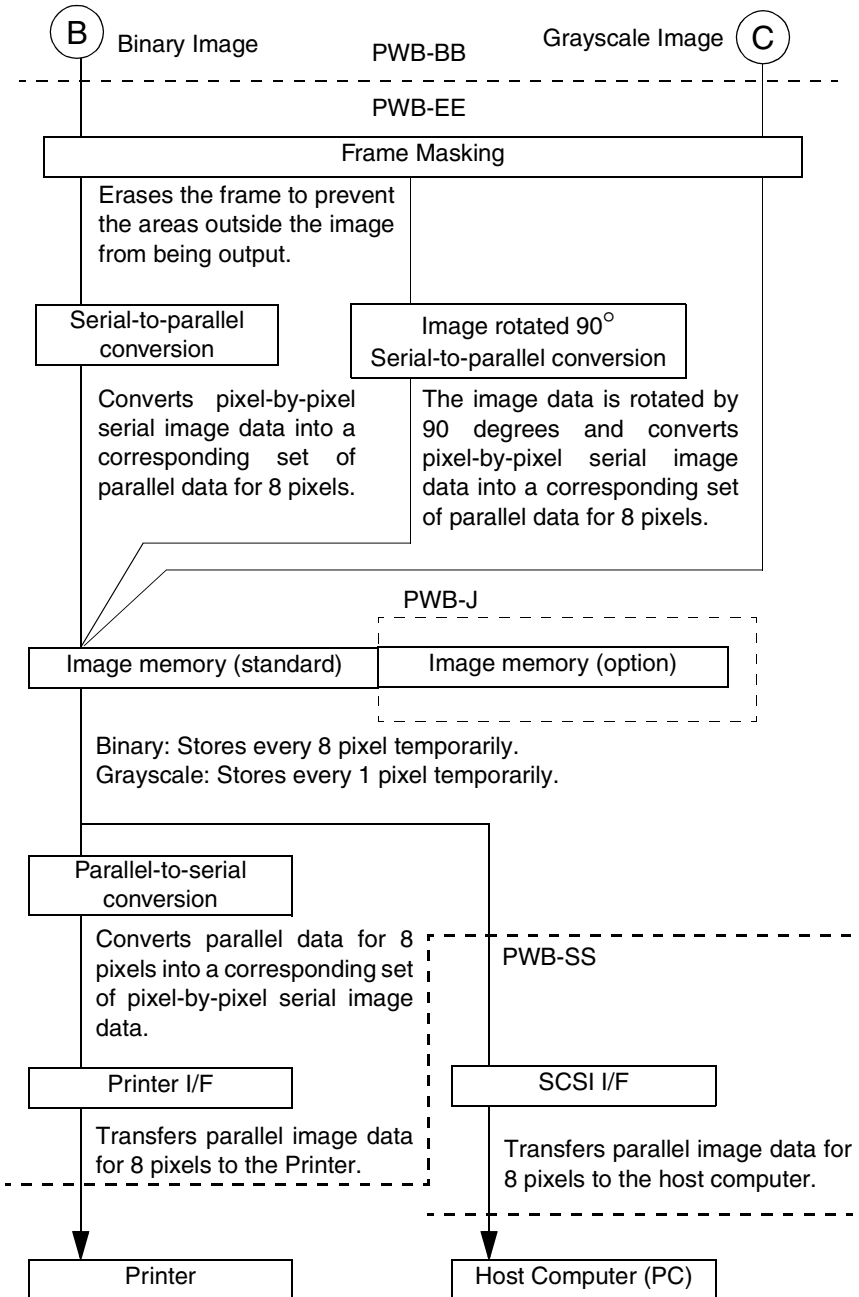

## 4.6 Auto Masking

### 4.6.1 Overview

If a print is made from an image that is projected smaller than the Markers on the screen, the non-image areas of the film result in black bands running around the image on the print.

The Auto Masking Function Automatically detects the non-image areas of the film.

### 4.6.2 Masking Area Detection

The CCD Board (PWB-A) is detects the density of the film image.

If Auto Masking is selected on the control panel, the CCD Board (PWB-A) detects the masking area (By measuring the intensity of light) while the Scan Mirror makes a prescan motion.

### 4.6.3 Requirements for Auto Masking

- Film Requirements

	Negative	Positive
Film Base Density	0.2 or less	0.8 or more
Background Density	0.8 or more	0.2 or more

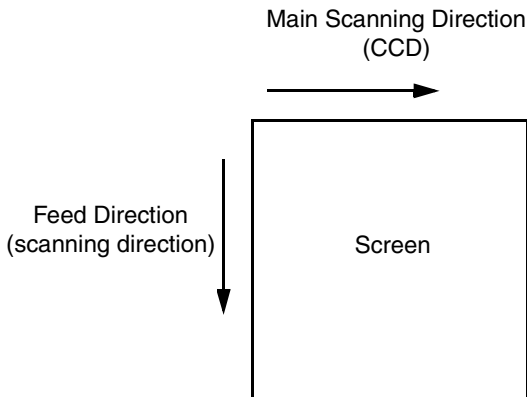

- Effective Image and Effective Frame

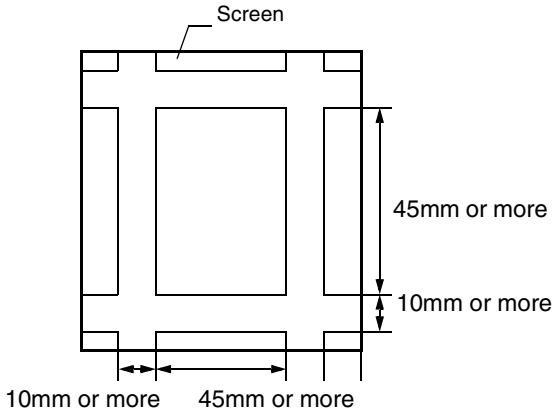

Effective Image Width: The image is considered as an image if it extends 45 mm or more .

Effective Frame Width: The frame is considered as a frame if it extends 10 mm or more.

\* The effective image width in the vertical and horizontal direction must be 45 mm or more.

- Memorandum Image Masking

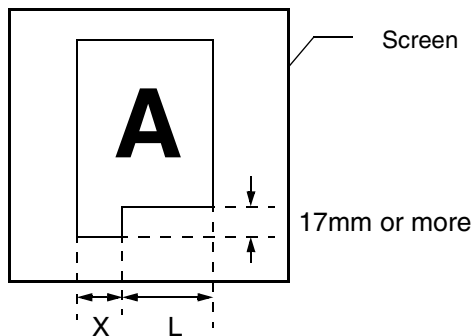

Image Width :  $X + L$

Memorandum Image width:  $X = 12\text{mm or more}$

Memorandum Image length: 17mm or more

$X \leq L - 17\text{mm}$  : Detected as a Blip

$L - 17\text{mm} < X \leq L + 17\text{mm}$ : Unfixed

$L + 17\text{mm} \leq X$ : Detected as a Blip

- Memo image away from the frame (A Island blip)

An island blip (a blip that positions away from the image) is not masked; it is considered as a normal.

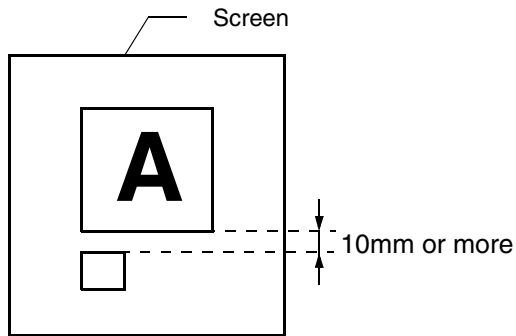

## 4.7 Auto Image Skew Correction

### 4.7.1 Overview

The CCD Board (PWB-A) detects the image which skew on the screen and corrects automatically at the time of scan.

Corrects of the straight image by rotating the prism unit by the auto image rotation motor (M5).

### 4.7.2 Requirements for Auto Skew Correction

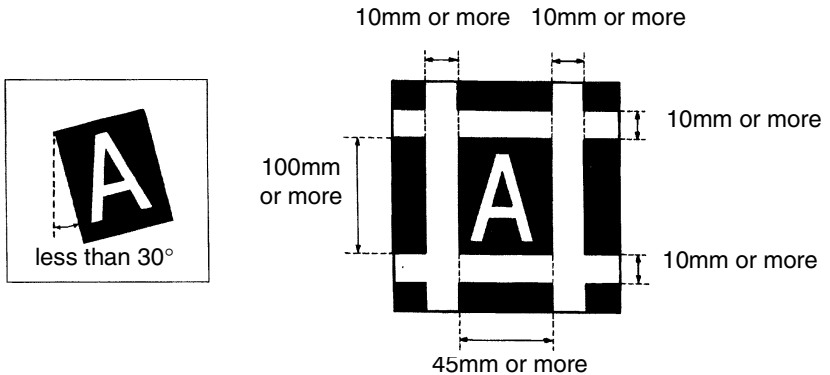

Image slant: less than 30°

Image Size: 100mm x 45mm or more

Frame of Image: 10mm or more

## 4.8 Manual Frame Masking

The machine makes a print of the area of image on the Screen defined with the Manual Masking Panels.

The print area is defined independently in the vertical direction and horizontal direction. If none is specified, the machine makes a normal print.

There are 42 LEDs/switches laid out both in the horizontal as well as vertical direction. Two Clear Buttons are placed; one at the bottom of the vertical row of LEDs/switches and the other on the left end of the horizontal row of LEDs/switches.

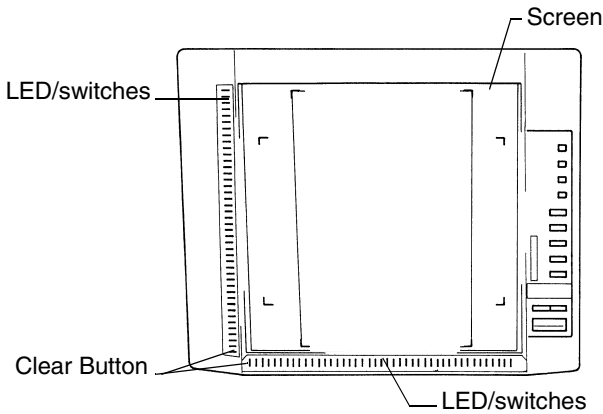

The machine makes a print of only the image area defined with the LED/Switches.

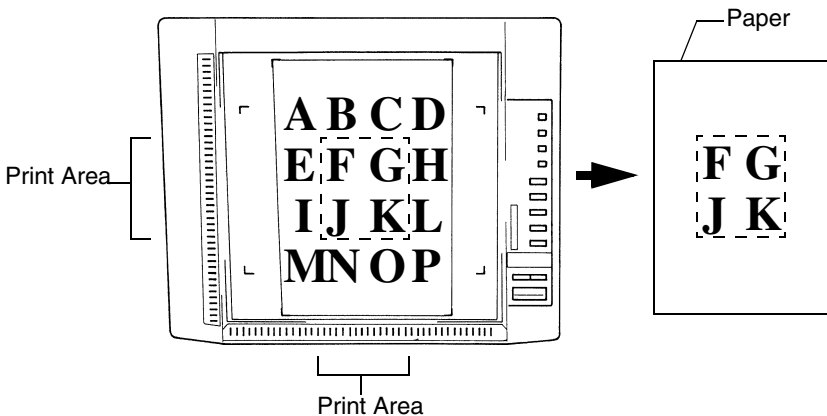

## 4.9 2 to 1 Printing Function

### 4.9.1 Overview

As shown above, two scanners, each equipped with the 2-to-1 Printing Function, can be connected to a single printer which manages the print jobs sent from both scanners.

Each scanner can be set to print marks (■ or ■■) in the top left-hand corner of the page, enabling easy identification of each scanner's print job.

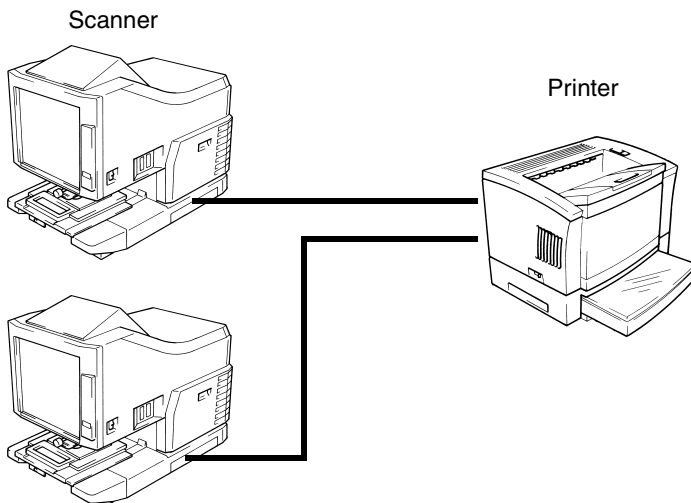

### 4.9.2 Operation

When printing, the scanner occupies the printer. When the print is ended, the scanner opens the printer.

The scanning begins when the start key to the other scanner is pushed. And waited that the printer is opened while storing the image in the memory in the scanner while printing.

Meanwhile, scanner is shown for the Multi-print display to blink, and not to accept the next scanning.

If the print of the preceding other scanner ends, and the printer is opened, the image stored in the memory as here occupies the printer is printed.

A job that is waiting to be printed can be cancelled by pressing the Clear/Stop key on the scanner that sent the job.

(Push the Clear/Stop Key three times when you used the print reserve function)

As a result, the print job is deleted from the memory and that scanner's Multi-print Display stops blinking and stays lit.



### 4.9.3 Identification Marks

In order to distinguish which scanner sent a print job, the scanners are equipped with an identification Mark Printing Function which has the following settings:

Function Mode	Setting	Identification Mark
S7	d0 d1 d2	no mark S7-d1: Prints pattern 1 (■) S7-d2: Prints pattern 2 (■)

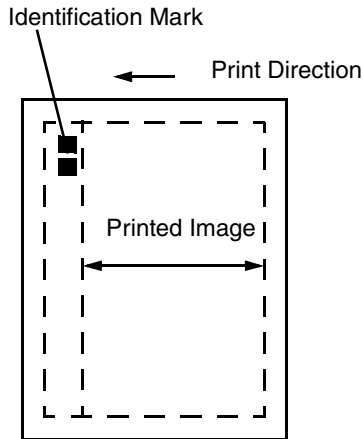

The printable area is reduced by 3 mm on the left side and the 1.5-mm-wide identification mark is printed in the top corner of the page at a distance of 1.5 mm to the left of the image.

## 5 Disassembly and Cleaning

### 5.1 Precautions

#### 5.1.1 Precautions for Disassembly and Cleaning

1. Before disassembling, always make sure the Power Plug is unplugged.
2. Use only fuses of the indicated rating.
3. Except specified occasion, re-assembly have to be carried out by reversing the disassembly procedure.
4. If it is necessary to plug in the Power Cord and operate the machine after disassembling it, please be careful of the following:
  - Keep your hands, clothing, etc. well away from operating or rotating parts (such as belts, rollers, fan motors, etc.).
  - Never touch the terminals of electrical parts or high-voltage parts (such as chargers and the high-voltage unit).
5. When the machine is stopped, the Projection Lamp is hot, so handle it very carefully.
6. To prevent damage to ICs from static electricity, do not touch the ICs on the PWB or the terminals of peripheral electricity parts with your hands.
7. Always unplug connectors by holding the connector housing. Pulling on the connectors on the PWBs themselves, always make sure the Power Cord is unplugged first.
8. Do not disassemble the Right and Left Frame Covers and the fixing screws to which red paint has been applied.

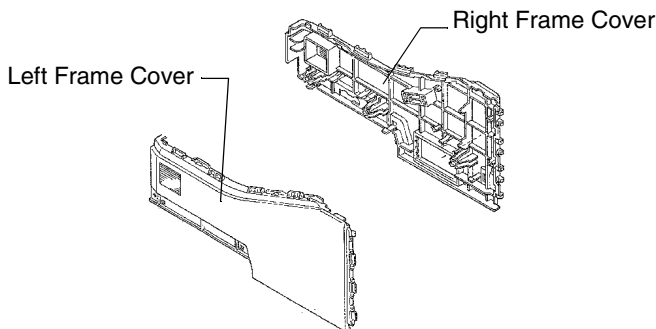

## 5.2 Handling of P.W.Boards

### 5.2.1 Precautions regarding transportation and storage

1. During shipment or when in storage, new P.W.Board must not be indiscriminately removed from their protective bags.
2. Do not store or place these P.W.Boards in a location exposed to direct sunlight or in a location where they will be exposed to high temperatures.
3. After removal from a machine, P.W.Board must be placed in their respective conductive bag or wrapped in aluminum foil without fail. Never wrap them in plastic, paper or any other material.
4. When removal from the conductive bag or case becomes absolutely necessary, always place the Board removed on its conductive mat in an area as free as possible from static electricity.
5. Do not touch the terminals of the ICs with your bare hands.

### 5.2.2 Precautions when replacing PWBs

1. Any Board should be replaced as an Assy.
2. When taking any Board out of its conductive bag or conductive case, do not touch the terminals of the ICs or the printed pattern. Place it in position by holding only the edge of the Board.
3. Connect the connectors to or disconnect them from any Board only after having unplugged the Main Power Cord of the machine.

### 5.2.3 Precautions when checking PWBs

1. Avoid checking PWBs with testers; instead, use operating parts of the machine, indicator lamps, and other means to evaluate operational conditions.
2. Never permit shorts between IC terminals due to metal fittings, etc.
3. If it is necessary to touch elements on the PWB with your hand, make sure your body is properly grounded.

## 5.3 Maintenance and Inspection

### 5.3.1 Preventive Maintenance Schedule List

Parts	Cleaning Cycle	Replacement Cycle	Refer to
Reader and Scan Path Mirrors	When image trouble occurs	-----	page 67
Friction Plate	-----	300,000 scans	page 73
Bushing	-----	300,000 scans	page 73
Projection Lamp	-----	When "L2" displays	page 65

\*Replacement cycle is the number of times of scan.

### 5.3.2 Details of readjustments needed when parts are replaced

Replacement of the following parts calls for rechecking, readjustments, or resetting of certain items.

Follow the corresponding procedure given below whenever they have been replaced.

Name	Readjustments /Resetting/Rechecking
PWB-A	1. Shading Correction "b6" 2. Auto Exposure Coarse Adjustment
PWB-BB	1. Shading Correction "b6" 2. Scan Speed Adjustment Turn off all DIP switches (DSW1) on the new board. Make the function mode setting (S,y,o) on the new board. ("About the Function Mode Setting Label" on page 82)
PWB-SS	Make the same SCSI ID setting for Rotary Switch (RSW1) on the new board as those of the old board.
PU2	Projection Lamp Voltage Adjustment "F7"

Refer to "Function Mode and Adjustment" on page 77 for the adjustment procedure.

## 5.4 Disassembly and Cleaning Procedure

### 5.4.1 Removal of the Outer Covers

- 1 Remove the two screws and then slide the Optical Cover to the rear side of the machine.  
Then holding up the rear side of the Optical Cover and remove it.

**NOTE:**

Mirror is fitted to the back side of the Optical Cover. Using care not to touch or damage this mirror, place the Optical Cover upside down.

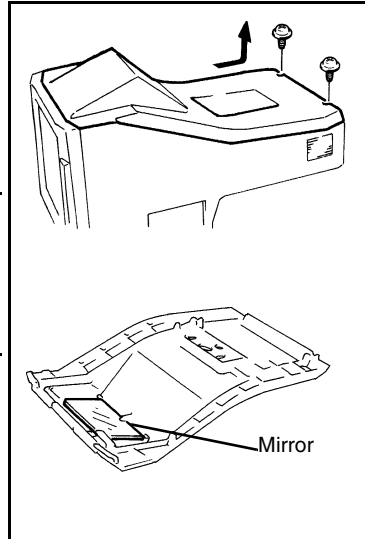

- 2 Holding up and remove the Screen Frame and then disconnect the connector of the Control Panel Board.

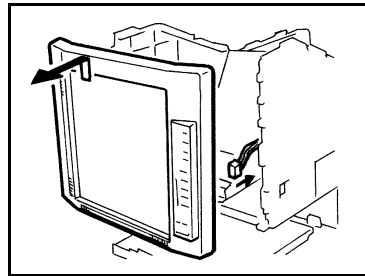

- 3 Remove the stopper from the Right Cover and then open the Right Cover.

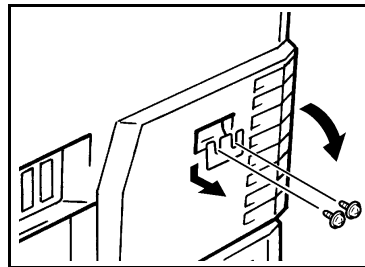

Only 220-240V area:

Remove the metal plate in the  
Left Cover also.

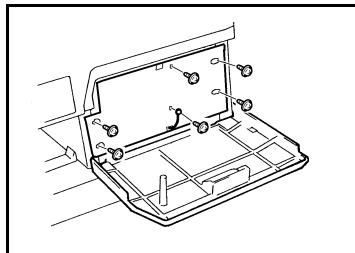

- 4** Remove the Left Cover.  
(1 screw)

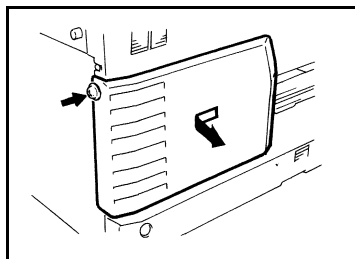

Only 220-240V area:

Remove the metal plate in the  
Right Cover also.

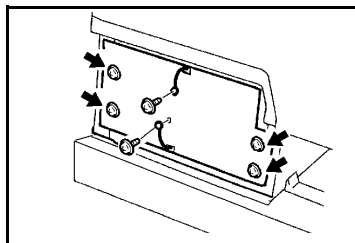

- 5** Remove the Projection Unit.

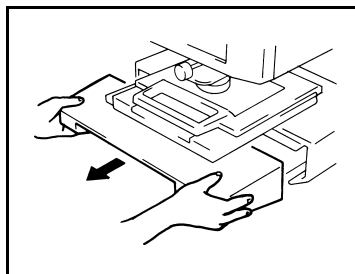

- 6** Remove the Lower Left Cover.  
(2 screws)

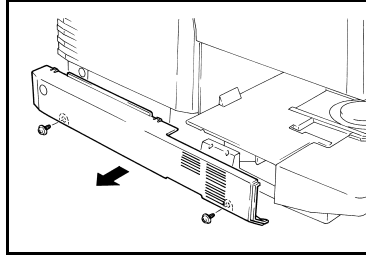

- 7** Remove the Lower Right Cover.  
(2 screws)

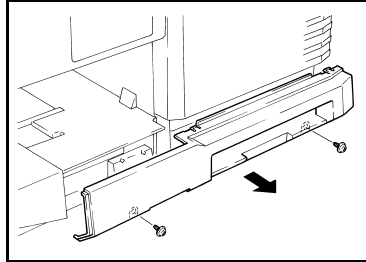

- 8** Remove the Rear Cover.  
(4 screws)

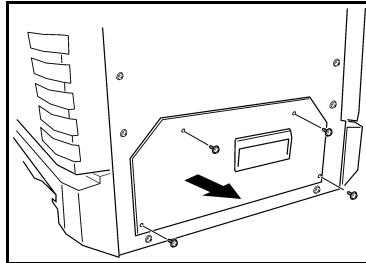

### 5.4.2 Replacing of the Projection Lamp

1 Slide the Projection Lamp Unit out.

2 Remove the Projection Lamp from the Lamp Holder.

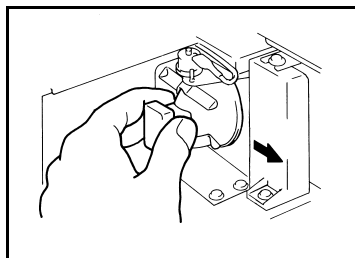

#### NOTE

→ Do not touch with bare hand and extremely hot Projection Lamp immediately after the machine has been turned OFF.

3 Remove the Projection Lamp from the Lamp Socket.

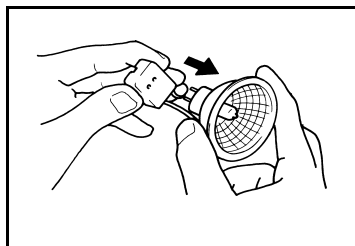

4 Insert a new Projection Lamp so that the mark on its base is facing upwards. Make sure that the new Projection Lamp is inserted securely so that there is no gap between the projection Lamp and the Lamp Socket.

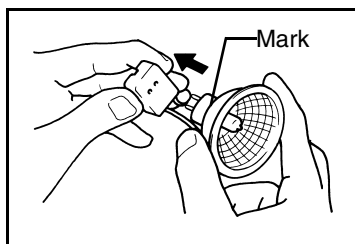

#### NOTE:

→ Do not touch the reflector mirror surface of the Projection Lamp.  
→ Fingerprints, smudges or debris should be wiped clean with a soft, dry cloth.



- 5 Insert the new Projection Lamp all the way into the Lamp Holder.
- 6 Slide the Projection Unit back into the machine.

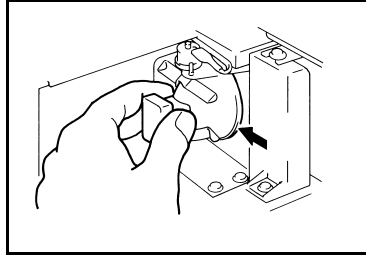

#### 5.4.3 Cleaning of the Projection Lamp

- 1 Wipe all foreign matter off the surface of the Projection Lamp with a soft piece of cloth which has been dampened with alcohol.

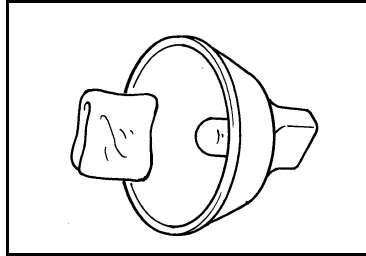

#### 5.4.4 Cleaning of the Condenser Lens and Mirrors

- 1 Remove the Projection Unit.
- 2 Dust off the surface of the Condenser Mirror by using a blower brush or a piece of soft cloth.

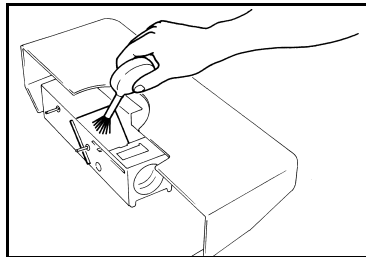

### 5.4.5 Cleaning of the each Mirrors

- 1 Remove the Optical Cover.
- 2 Wipe clean the 1st Reader Path Mirror with a soft piece of cloth.

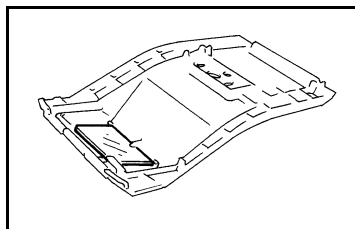

- 3 Wipe clean the 2nd Reader Path Mirror with a soft piece of cloth.

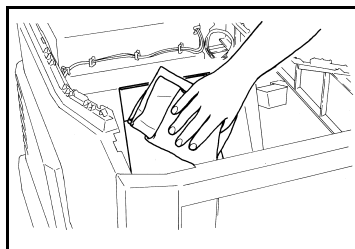

- 4 Remove the Left Cover. (1 screw)

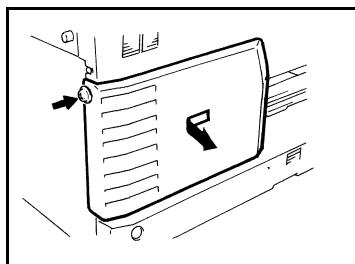

Only 220-240V area:

---

Remove the metal plate in the  
Left Cover also.

---

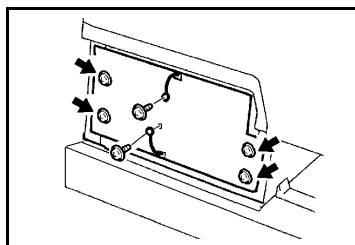

- 5** Wipe clean the 2nd and 3rd Scan Path Mirror with a soft piece of cloth.

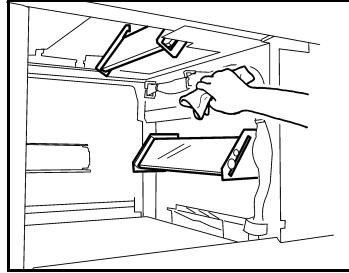

#### 5.4.6 Cleaning of the CCD Filter

- 1** Remove the Left Cover.  
(1 screw)

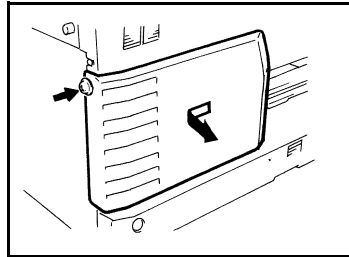

Only 220-240V area:

Remove the metal plate in the Left Cover also.

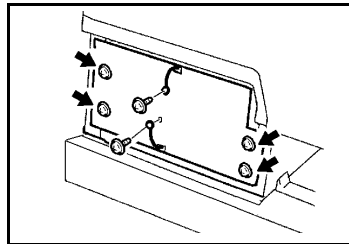

- 2** Dust off the surface of the CCD Filter by using a blower brush or a piece of soft cloth.

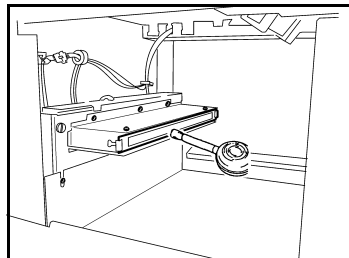

### 5.4.7 Removal of the CCD Assy

- 1 Remove the stopper from the Right Cover and then open the Right Cover. (2 Screws)

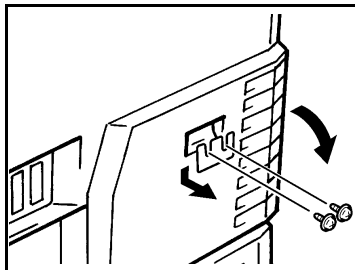

Only 220-240V area:

Remove the metal plate in the Left Cover also.

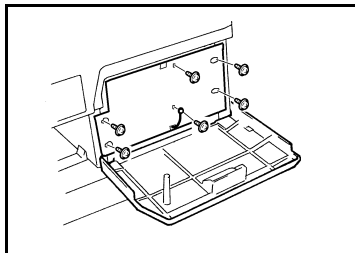

- 2 Remove the Left Cover. (1 screw)

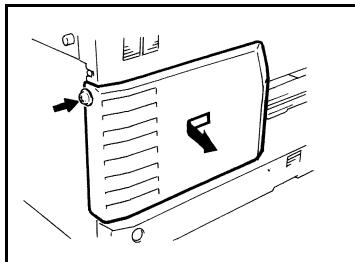

Only 220-240V area:

Remove the metal plate in the Left Cover also.

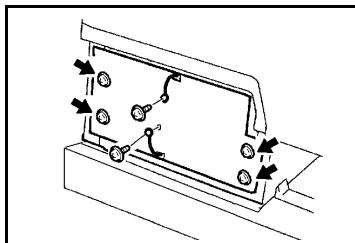

- 3** Remove the CCD Assy Lower Plate.  
(2 screws)

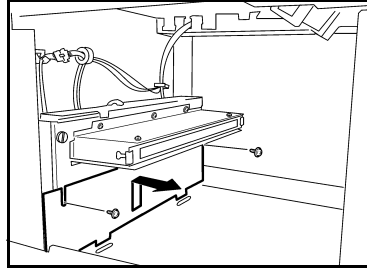

- 4** Remove the CCD Assy.  
(two shoulder screws, Three connectors)

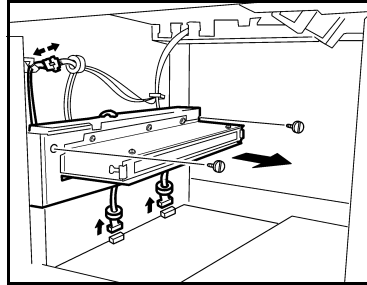

- 5** Unplug connector from the CCD Assy.

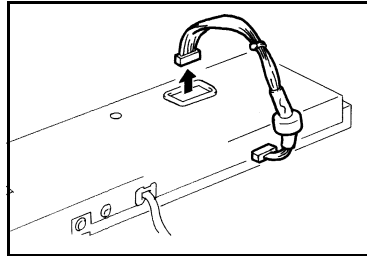

- 6** Remove the CCD Assy Cover.  
(loosen the four screws)

**NOTE:**

After the CCD Assy has been mounted, make the shading correction (b6) by following the procedure given on page 104.

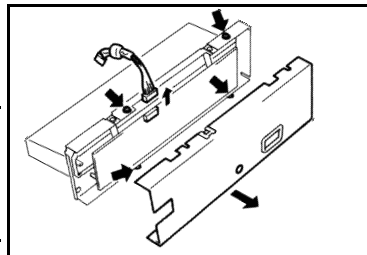

### 5.4.8 Removal of the Power Unit

- 1 Remove the Optical Cover.  
(2 screws)

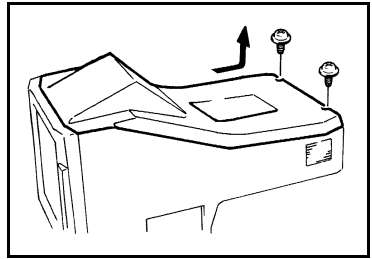

- 2 Disconnect the five Connectors of the Power Unit from the machine.

**NOTE:**

---

For 220-240V area, disconnect the 2P connector of the Coil also.

---

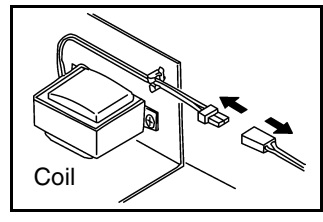
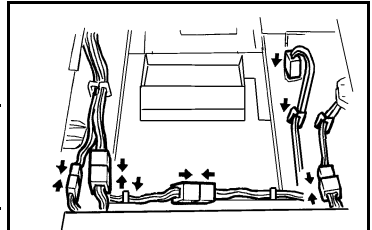

- 3 Remove three screws and then remove the Power Unit from the machine.(3 screws)

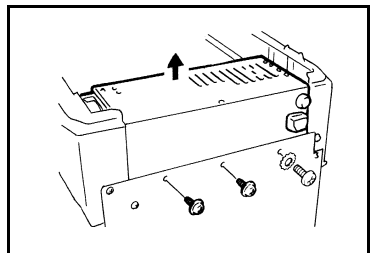

### 5.4.9 Removal of the P.W.Boards.

- 1 Remove the Left Cover, Lower Left Cover and Rear Cover.  
(Refer to "Removal of Outer Cover".)
- 2 Open the Right Cover.  
Only 220-240V area:  

---

Remove the metal plates in the  
Left and Right Cover also.  

---
- 3 Remove the CCD Assy Lower  
Cover. (2 screws)

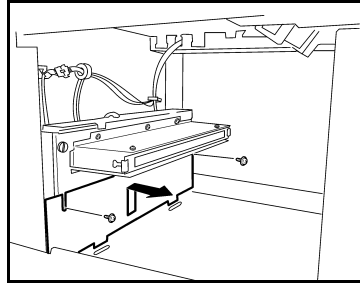

- 4 Remove the front and rear Shield  
Plate. (loosen the four screws)

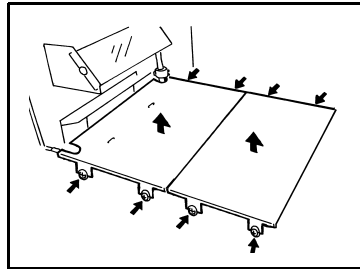

- 5 Unplug all connectors on the  
P.W.Board.
- 6 Remove the screws and then  
remove the each P.W.Board.

- PWB-BB (5 screws)
- PWB-T (4 screws)
- PWB-EE (6 screws)

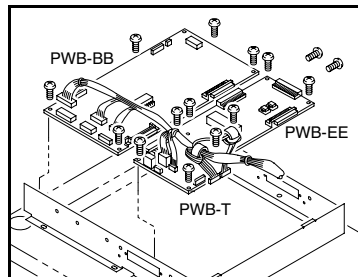

### 5.4.10 Replacing Scan Motor bushing and friction plate

- 1 Remove the Optical Cover.  
(2 screws)

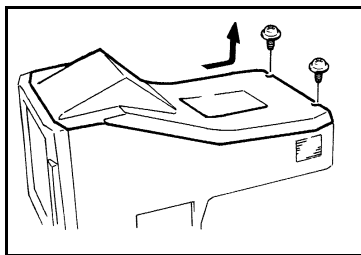

- 2 Tilt the Scan Motor Assy in the direction of the arrow and, pressing the shaft in the direction of the arrow, re-move the bushing and then peel the friction plate off the Scan Motor Assy.

NOTE:

Do not lose the pin.

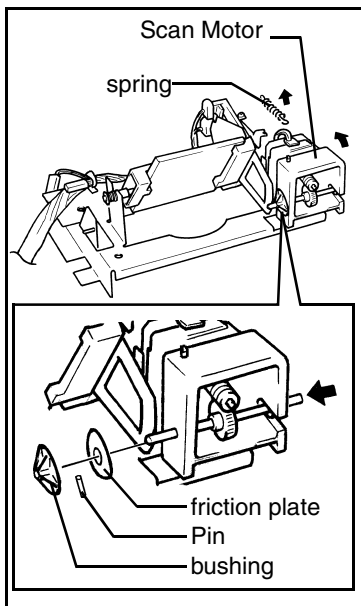

### 5.4.11 Replacing the Fuse of the Power Unit

- 1 Remove the Optical Cover.  
(2 screws)

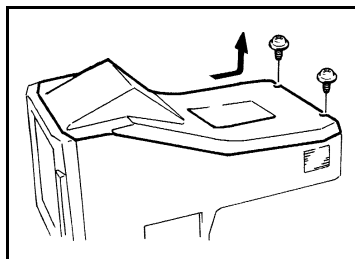



- 2** Remove the Power Unit Cover.  
(3 screws)

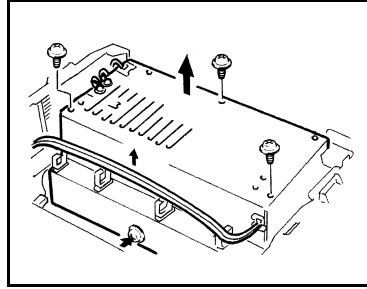

- 3** Replace the Fuse of PU1.

Main Power Unit: PU1

AC250V 12A(100/120V area)

AC250V 6.3A(220/240V area)

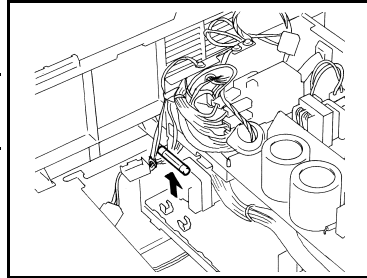

- 4** Replace the Fuse of PU2.

Projection Lamp Regulator: PU2

AC125V 5A(100/120V area)

AC250V 5A(220/240V area)

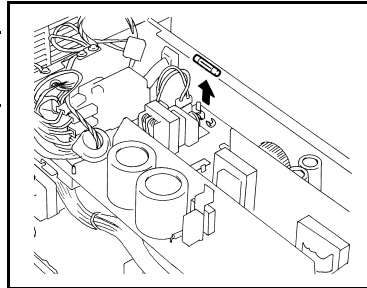

#### 5.4.12 Replacing the Main Fuse

- 1** Replace with New Fuse.

Main Fuse:

120V area: 250V 10A

220/240V area: 250V 6.3A

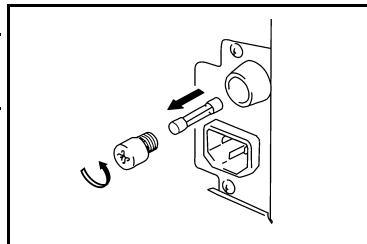

### 5.4.13 Exchanging the Oscillator Chip

When using MSP2000 printer, you must exchange the Oscillator Chip (OSC1) on Printer I/F Board (PWB-EE) of the Microfilm Scanner for the Oscillator Chip supplied with MSP2000 Printer.

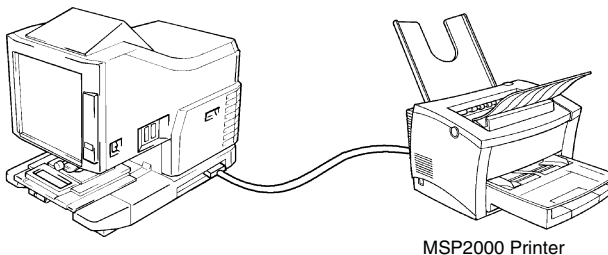

- 1 Remove the Projection Unit.

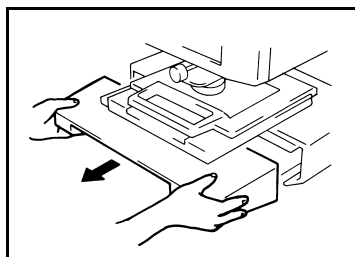

- 2 Remove the Lower Left Cover.

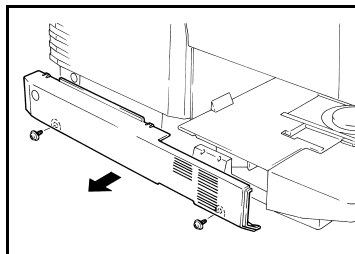

- 3 Remove the stopper from the Right Cover and then open the Right Cover.

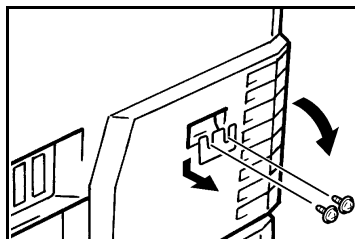

Only 220-240V area:

Remove the metal plate in the  
Right Cover also.

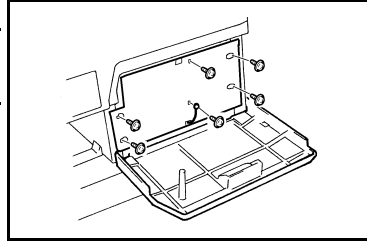

4 Remove the Shield Cover (front).

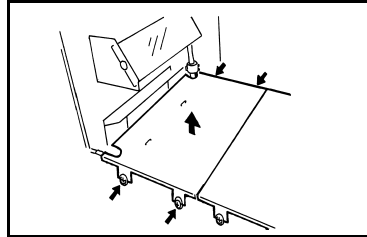

5 Remove the two Oscillator Chips  
from PWB-EE.

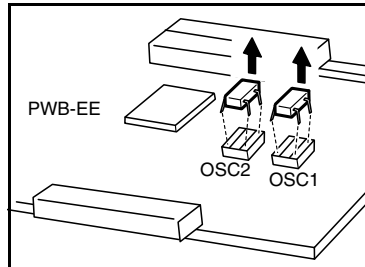

6 Install the Oscillator Chip supplied into the OSC1 socket as shown on  
the illustration

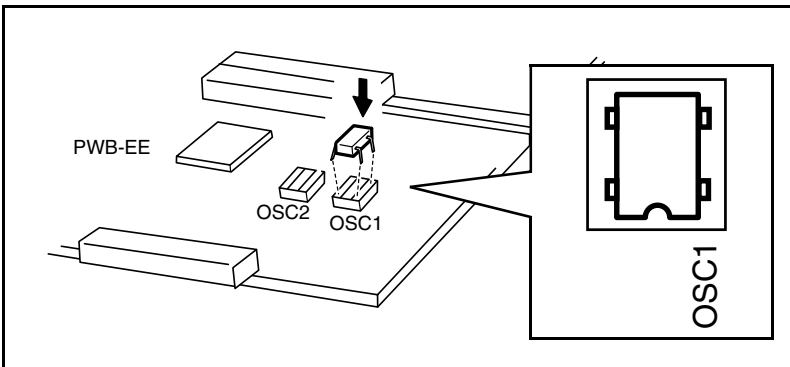

7 Reinstall all the covers.

## 6 Function Mode and Adjustment

### 6.1 Precautions

1. Always unplug connectors by holding the connector housing. Pulling on the cable cord can lead to problems with poor contact. When unplugging connectors on the PWBs themselves, always make sure the power is OFF first.
2. If it is necessary to plug in the power cord and operate the machine after disassembling it, please be careful of the following.
  - Keep your hands, clothing, etc. well away from operating or rotating parts (such as gears and fan motors, etc.).
  - Never touch the terminals of electrical parts or high-voltage parts (such as power unit.).
3. See DISASSEMBLY AND CLEANING for the procedures to replace parts and disassemble the machine.
4. Before starting the adjustment procedures, always make sure that the power cord has been unplugged.

### 6.2 Overview

The function mode which performs setting and adjustment of the machine is constituted as follows.

Display	Function Mode	Contents
5	S mode	Machine Function Setting Mode 1
4	y mode	Machine Function Setting Mode 2
0	o mode	Machine Function Setting Mode 3
F	F mode	Machine Operation Check Function 1
b	b mode	Machine Operation Check Function 2

\* mark in column of "setting" expresses an in default setting.

## 6.3 Function Mode List

### 6.3.1 S mode (Setting Function 1)

No.	Function	Setting	Contents
S1	Auto Reset	*d0 d1	ON (60 sec.) OFF
S2	Auto Power Save	*d0 d1 d2	Disable Enable (30 minute) Enable (60 minute)
S3	Auto Projection Lamp OFF	*d0 d1 d2	Disable Enable (30 minute) Enable (60 minute)
S4	Coin Vender & Foot Switch	*d0 d1 d2 d3	Disable Enable (Coin Vender) Enable (Coin Vender) Enable (Foot Switch)
S5	Fine Mode	*d0 d1	Mode 1: Contrast Emphasis Mode 2: Outline Emphasis
S6	Paper Tray Feed Size (MSP3000 Printer)	*d0 d1	Crosswise Lengthwise
S7	Machine ID Printing	*d0 d1 d2	None Pattern 1 Pattern 2
S8	Cycle Print Mode	*d0 d1	Disable Enable
S9	Contrast Adjustment (N-P)	d1   *d8   dF	Lower   Center   Higher
SA	Contrast Adjustment (P-P)	d1   *d8   dF	Lower   Center   Higher
Sb	Scan Table Stop Position Adjustment (Scan Position)	d0   dF	toward the rear   toward the screen
SC	Scan Table Stop Position Adjustment (Reader Position)	d0   dF	toward the screen   toward the rear
Sd	Auto Image Rotation 90 degree rotation Function	*d0 d1	Disable Enable
SE	The print function at the time of Toner Empty detection	*d0 d1	print is impossible. print is possible.

**6.3.2 y mode (Setting Function 2)**

No.	Function	Setting	Contents
y1	Not Used	*d0	
y2	Auto Paper Source Switching	*d0 d1	Auto Switching Disabling Auto Switching
y3	Auto Film Format Select Print	d0 d1	Disable Enable
y4	Not Used	*d0	
y5	Memo Image Masking	*d0 d1	OFF ON
y6	Prescan Operation	*d0 d1	2 times 1 time
y7	Auto Skew Correction Retain	*d0 d1	Retain Not Retain
y8	Not Used	*d0	
y9	Not Used	*d0	
yA	Not Used	*d0	
yb	Magnification Warning Display	d0 *d1	Not Display Display
yC	Print Reserve Function	d0 *d1	Not Accepts Accepts

y3:default setting (d0: USA and Canada Area, d1:except USA and Canada Area)

### 6.3.3 o mode (Setting Function 3)

No.	Function	Setting	Contents
o1	Metric/Inch Setting	d0 d1	Metric Inch
o2	N-P Auto Exposure Coarse Adjustment	d4   dC	Lighter   Darker
o3	P-P Auto Exposure Coarse Adjustment	d4   dC	Lighter   Darker
o4	Scan Speed Adjustment	d5   db	Lager   Smaller
o5	Adjustment of the image area Lengthwise Position	d5   db	Shift to a Top   Shift to Bottom
o6	Adjustment of the Right and Left Frame Black Band Width	d5   db	band width decreases   band width increases
o7	Adjustment of the Top and Bottom Frame Black Band Width	d5   db	band width decreases   band width increases
o8	Projection lamp burn out detection (L2) setting	*d0 d1	Detects Not Detects
o9	Not Used	*d0	
oA	Host Driver	*d0 d1 d2	MS 6000 MS 2000 MicroDAX (Fixed Window)
ob	Vender Name/Model Name	*d0 d1 d2	Minolta MS 6000 Minolta MS 2000 OEM Name

**6.3.4 F mode (machine operation checks)**

No.	Function	Contents
F1	ROM Version Check	Displays the present ROM version.
F2	Total Scan Counter	Displays the number of times of total scan.
F3	Total Print Counter	Displays total print number of sheets.
F4	Counter Clear	Clears the number of times of total scan, and print number of sheets.
F5	LED Check (Control Panel)	Lights up all the LEDs on the Control Panel for 2 sec.
F6	for Factory use	Do not use in field.
F7	Projection Lamp Voltage Adjustment	Makes adjustment of the Projection Lamp (LA1) reference voltage.
F8	Reset the Setting Data	Function mode setting value and job program are reset to the default value.

**6.3.5 b mode (machine operation checks)**

No.	Function	Contents
b1	Scan Table Unit drive check	Moves the Scan Table into reader and scan position.
b2	Scan Mirror operation check	Moves the Scan Mirror into reader and scan position.
b3	for Factory use	Do not use in field.
b4	Prism Rotation drive check	Checks an operation of Auto Image Rotation Motor.
b5	Single Scan function check	Turn the machine in the single scan operation.
b6	Shading Correction	Performs the Shading Correction.
b7	Test Print	Performs the Test Print of the Printer.
b8	for Factory use	Do not use in field.



### 6.3.6 About the Function Mode Setting Label

Remove the Top Cover by using a Slotted Screwdriver.

[FUNCTION MODE SETTING] Label is attached on the back of the Top cover.

When Main Control Board (PWB-BB) is exchanged, it inputs the setting value of "FACTORY" column on the label into each Function Mode.

Moreover, when setting value is changed in field, it writes setting value to the "FIELD" column.

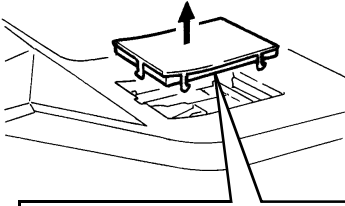

FUNCTION MODE SETTING ファンクションモード設定								
	FACTORY	FIELD		FACTORY	FIELD		FACTORY	FIELD
	工場設定	市場設定		工場設定	市場設定		工場設定	市場設定
S1	d	d	y1	d0	d	o1	d	d
S2	d	d	y2	d0	d	o2	d	d
S3	d0	d	y3	d	d	o3	d	d
S4	d0	d	y4	d0	d	o4	d	d
S5	d0	d	y5	d0	d	o5	d	d
S6	d	d	y6	d0	d	o6	d8	d
S7	d0	d	y7	d0	d	o7	d8	d
S8	d0	d	y8	d0	d	o8	d0	d
S9	d8	d	y9	d0	d	o9	d	d
SA	d8	d	yA	d0		oA	d	
Sb	d	d	yb	d		ob	d	
SC	d	d	yC	d				
Sd	d0	d						
SE	d0	d						

## 6.4 Operation of the Function Mode

### 6.4.1 Entering the Function Mode

1. Press the Exposure Mode Select Key, Multi-Print Key and Clear/Stop Key on the control panel at the same time for two seconds or more.  
The Multi-Print Display will show "S".

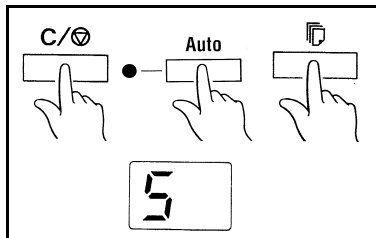

2. Press the Multi-Print Key to select the function mode. Each depression of this key changes the mode into the following.

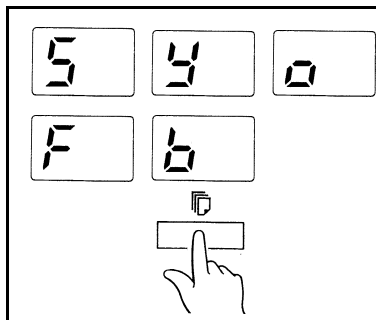

S→y→o→F→b→S→y....

S: Setting Function 1

y: Setting Function 2

o: Setting Function 3

F: Machine Operation Check Function 1

b: Machine Operation Check Function 2

\*c4: for factory use (do not entry)

3. Press the Exposure Adjustment Key to select the function number.

S1→S2→...→S1→

y1→y2→...→y1→

o1→o2→...→o1→

F1→F2→...→F1→

b1→b2→...→b1→

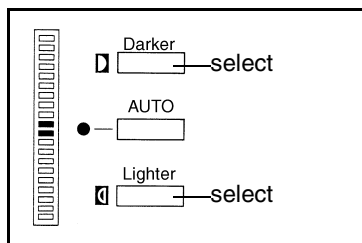

### 6.4.2 Execution method in F and b mode (except F4, F8 and b6)

1. To perform the function, press the Start key.

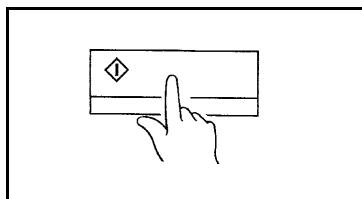

### 6.4.3 Execution method in F and b mode (F4, F8 and b6)

1. To perform the function, press the Mode Memory Key.

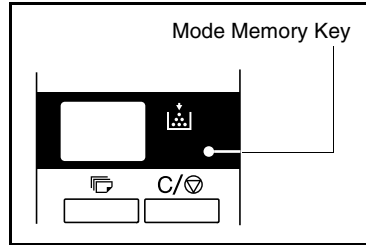

### 6.4.4 Execution method in S, y and o mode

1. Press the Exposure Mode Select Key.
2. The present setting value is displayed on the display window.

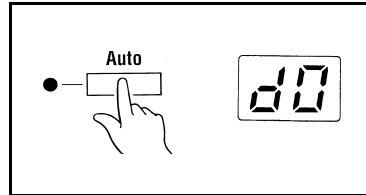

3. Press the Exposure Adjustment Key to select the setting number.

d0→d1→.....→d7→d8

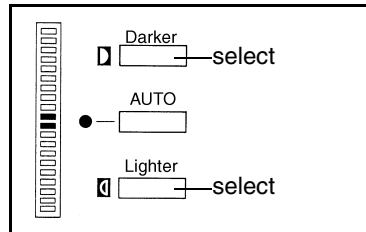

4. Press the Start Key to update the setting value.

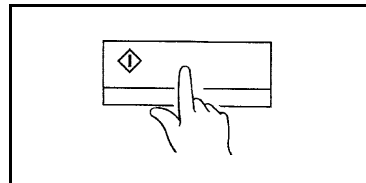

### 6.4.5 Leaving the Function Mode

1. Press the Exposure Mode Select Key, Multi-Print Key and Clear/Stop Key on the Control Panel at a time.

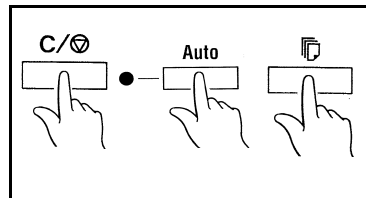

## 6.5 S mode Operations

### 6.5.1 S1: Auto Reset

Setting changes made to the control panel that are not used within 60 seconds of being input are automatically cancelled and the system reverts back to the original settings.

Display	setting	Function
S1	*d0 d1	Enable (60 seconds) Disable

### 6.5.2 S2: Auto Power Save

Turns the Printer's fuser OFF if the system is left idle for a specific period of time.

\* 200V units operate on a default 30 minute Auto Power Save setting.

Display	setting	Function
S2	*d0 d1 d2	Disable Enable (30 minute after) Enable (60 minute after)

### 6.5.3 S3: Auto Projection Lamp OFF

Turns the Scanner's Projection Lamp OFF if the system is left idle for a specified period of time.

Display	setting	Function
S3	*d0 d1 d2	Disable Enable (30 minute after) Enable (60 minute after)

### 6.5.4 S4: Coin Vender / Foot Switch Setting

When you equip this system with the coin vender (option) or Foot Switch (option), select the d1(d2) or d3.

Display	setting	Function
S4	*d0 d1 d2 d3	Disable Enable (Coin Vender) Enable (Coin Vender) Enable (Foot Switch)

\*d1 and d2 are the same functions.

### 6.5.5 S5: Fine Mode Setting

Select the function in the fine mode, when selecting Nega print mode on the control panel.

Display	setting	Function	Contents
S5	*d0	Mode 1: Contrast Emphasis	Applied when film contains text that is poorly contrasted against its background making it difficult to read.
	d1	Mode 2: Outline Emphasis	Applied when film contains blurred black and white images.

### 6.5.6 S6: Paper Tray feed size (MSP 3000 Printer)

Determines the desired paper size supplied by the Paper Tray of the printer. It is possible to feed the following paper sizes and orientations into the printer:

Inch values: Letter (Lengthwise) or Letter (Crosswise)

Metric values: A4 (Lengthwise) or A4 (Crosswise)

Display	setting	Function
S6	*d0	Crosswise
	d1	Lengthwise

### 6.5.7 S7: Machine ID Printing

When two scanners are connected to one printer, this function leaves an identification marker (■) on the print so that the scanner used for the job can be determined after printing.

Display	setting	Function
S7	*d0	None
	d1	Pattern 1
	d2	Pattern 2

Pattern Dimension:  
3mm x 3mm  
Mark Position:  
Right side of leading edge

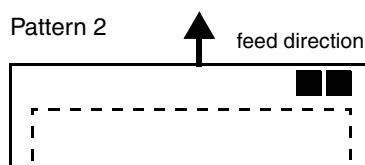
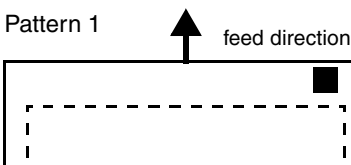

### 6.5.8 S8: Cycle print mode

This function automatically scans the next image following a preset period of time. Images are set by the user onto the Carrier Glass in between cycles.

Display	setting	Function
S8	*d0 d1	Disable Enable

### 6.5.9 S9: Nega Contrast Adjustment

Adjusts contrast in the negative film use.

Display	setting	Contrast
S9	d1   *d8   dF	Lower   Center   Higher

### 6.5.10 SA: Posi Contrast Adjustment

Adjusts contrast in the positive film use.

Display	setting	Contrast
SA	d1   *d8   dF	Lower   Center   Higher

### 6.5.11 Sb: Scan Table Stop Position Adjustment (Scan Position)

This adjustment is necessary when any of the following symptoms occurs.

Symptom 1.	Each time a print is made, the image on the Screen shifts vertically.
Symptom 2.	The noise becomes big that is heard when the Scan Table hits against the Scan Table Stopper during its motion from the reader position to printer position.

Display	setting	Scan Table Stop Position
Sb	d0	toward the rear
	d8	center
	dF	toward the screen

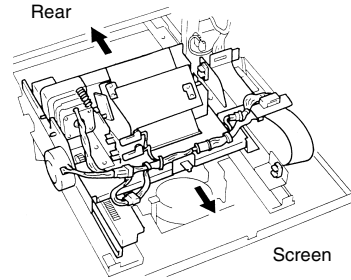

\* The stop position of the Scan Table should be set toward the rear for symptom 1 explained above and toward the screen for symptom 2.

### 6.5.12 SC: Scan Table Stop Position Adjustment (Reader Position)

This adjustment is necessary when any of the following symptoms occurs.

Symptom 1.	Each time a print is made, the image on the Screen shifts vertically.
Symptom 2.	The noise becomes big that is heard when the Scan Table hits against the Scan Table Stopper during its motion from the reader position to printer position.

Display	setting	Scan Table Stop Position
SC	d0	toward the screen
	d8	center
	dF	toward the rear

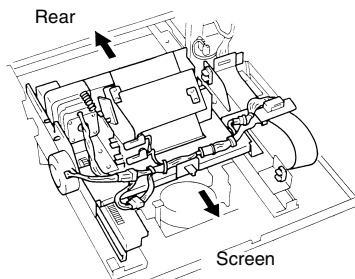

\* The stop position of the Scan Table should be set toward the screen for symptom 1 explained above and toward the rear for symptom 2.

**6.5.13 Sd: Auto image rotation 90 degree rotation function**

When printing the A3 (Ledger) size or B4 (Legal) size by 600dpi, the 90 degrees electric image rotation is not possible.

Select whether to enable the 90 degrees image rotation with the prism when A3 size (Ledger) or the B4 size (Legal) is printed with 600dpi.

The landscape screen image can be printed by effectively setting when the prism is installed.)

Display	setting	Function
Sd	*d0 d1	Disable Enable

**6.5.14 SE: The print function at the time of Toner Empty detection**

Selects the printing function in the case of detecting the Toner Empty of the printer.

Display	setting	Function
SE	*d0 d1	print is impossible print is possible



## 6.6 y mode Operations

### 6.6.1 y2: Auto Paper Source Switching

Allows you to specify the paper source when same size paper is loaded into the both paper feeding tray and paper feeding cassette.

Display	setting	Function	Function
y2	*d0	Auto switching	Printing continues by automatically switching to the remaining paper source after paper in the specified paper source runs out.
	d1	Disabling Auto Switching	A paper empty mode occurs and printing ceases after paper in the specified paper source runs out. The paper source must be refilled or the paper source must be switched by pressing the Size Selection Key in order to resume printing.

### 6.6.2 y3: Auto Film Format Select Print

Selects the function which rotates 90 degrees and prints a screen image. When only the landscape paper is set to the printer, the portrait screen image can be printed on the landscape paper by this setting.

Display	setting	Function
y3	*d0	Disable
	d1	Enable

### 6.6.3 y5: Memo Image Masking

If film with a memo image on it at the bottom of its frame is scanned with Auto Masking enabled, the memo image is erased by Auto Masking. In this case, setting y5 to the ON (d1) position will prevent the memo image from being masked.

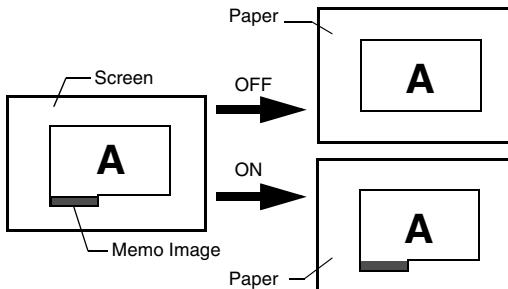

Display	setting	Function
y5	*d0	OFF
	d1	ON

### 6.6.4 y6: Prescan Operation

Select the prescan operation when using an Auto Masking and Auto Skew correction function.

Display	setting	Function	Explanation
y6	*d0	1 time	Reading speed is quick.
	d1	2 times	Although reading is late, but accuracy of Frame Masking becomes good.

### 6.6.5 y7: Auto Skew Correction Retain

Determines whether or not to retain the original (uncorrected) skew of a screen image after the print has been made.

Display	setting	Function
y7	*d0	Retained
	d1	Not retained

### 6.6.6 yb: Magnification Warning Display

Select whether to display the magnification warning when the modification of the standard magnification by an electronic zoom function.

Display	setting	Function
yb	*d0	Not display
	d1	Display

### 6.6.7 yC: Print Reserve Function

Select whether to accept the print reserve function while the printer is warming up.

Display	setting	Function
yC	d0	Not accepts
	*d1	Accepts

## 6.7 o mode Operations

### 6.7.1 o1: Inch/Metric Select

Select the inch or metric setting of the machine.)

Display	setting	Function
o1	d0 d1	Metric Inch

### 6.7.2 o2: N-P Auto Exposure Coarse Adjustment

This adjustment is made when the image density on the print (scan) output in the Auto Exposure mode is not satisfactory.

This adjustment is necessary after the replacement of PWB-A and PWB-BB.

Be sure to adjust the Projection Lamp Voltage (F7) and Shading Correction (b6) before this Adjustment.

1. Turn the Power Switch, set the Auto Exposure Mode into Auto and select the center position of exposure level.
2. Make a print (scan) and check the image density.
 

<Conditions of printing/scanning>  
 Print Mode .....Text  
 Film Type .....Nega
3. Refer to the charts given below.  
 Then, adjust to desired image density by Function Mode o2.

o2		
Setting	Function	Image density
d4	4 step lighter	
d5	3 step lighter	
d6	2 step lighter	
d7	1 step lighter	
d8	Standard	
d9	1 step darker	
dA	2 step darker	
db	3 step darker	
dC	4 step darker	

### 6.7.3 o3: P-P Auto Exposure Coarse Adjustment

This adjustment is made when the image density on the print (scan) output in the Auto Exposure mode is not satisfactory.

This adjustment is necessary after the replacement of PWB-A and PWB-BB.

Be sure to adjust the Projection Lamp Voltage (F7) and Shading Correction (b6) before this Adjustment.

1. Turn the Power Switch, set the Auto Exposure Mode into Auto and select the center position of exposure level.
2. Make a print (scan) and check the image density.

<Conditions of printing/scanning>

Print Mode .....Text

Film Type .....Posi

3. Refer to the charts given below.  
Then, adjust to desired image density by Function Mode o3.

o3		
Setting	Function	Image density
d4	4 step lighter	
d5	3 step lighter	
d6	2 step lighter	
d7	1 step lighter	
d8	Standard	
d9	1 step darker	
dA	2 step darker	
db	3 step darker	
dC	4 step darker	

### 6.7.4 o4: Scan Speed Adjustment

This operation is used to match the width on the Screen image with that on the print (scan) image.

This adjustment is necessary after the replacement of PWB-BB.

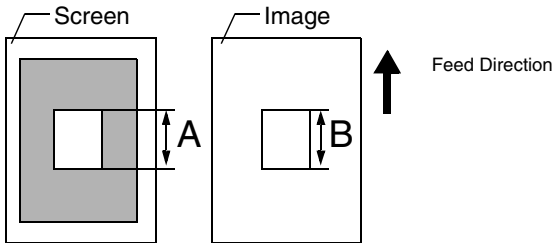

1. Load the Film in the machine and make a print (scan).  
 <Conditions of printing/scanning>  
 Size: Letter (A4) Lengthwise  
 Centering:OFF  
 Masking:OFF
2. Measures the width of the image A on the Screen and on the print to obtain any difference.
3. If the difference exceeds  $\pm 0.6\%$ , make the following adjustment.
4. Adjusting the o4 of the Function Mode so that the width distance between A and B can be within  $\pm 0.6\%$

o4		
Setting	Variation (%)	Image
d5	+1.92	Larger ↑ ↓ Smaller
d6	+1.28	
d7	+0.64	
d8	0.00	
d9	-0.64	
dA	-1.28	
dB	-1.92	

### 6.7.5 o5: Adjustment of the image area Lengthwise Position

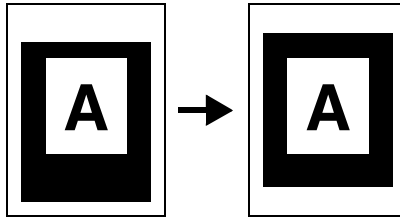

1. Load the Film in the machine and make a print (scan).  
 <Conditions of printing/scanning>  
 Size: Letter (A4) Lengthwise  
 Centering:OFF  
 Auto Masking:ON
2. Check the black band width of top and bottom on the print (scan) image.
3. Refer to the charts given below. Then, adjust for top black band width to become the same as bottom black band width by Function Mode o5.

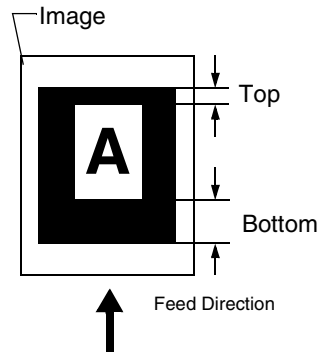

o5	
Setting	Border Shift Value (mm)
d5	-3
d6	-2
d7	-1
d8	0
d9	1
dA	2
db	3

bottom frame increases  
 ↑  
 ↓  
 top frame increases

### 6.7.6 o6: Adjustment of the Top and Bottom Frame Black Band Width

1. Load the Film in the machine and make a print.

<Conditions of printing/scanning>  
 Size: Letter (A4) Lengthwise  
 Centering:OFF  
 Auto Masking:ON

2. Check the width of the black band running around the image area.
3. Refer to the charts given below. Then, adjust to desired black band width by Function Mode o6.

o6		
Setting	Adjusted black band width (mm)	
d5	-6±3	<div style="text-align: center;">           band width decreases            ↑            ↓            band width increases         </div>
d6	-4±3	
d7	-2±3	
d8	0±3	
d9	2±3	
dA	4±3	
db	6±3	

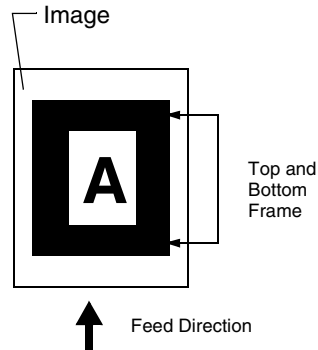

### 6.7.7 o7: Adjustment of the Right and Left Frame Black Band Width

1. Load the Film in the machine and make a print (scan).

<Conditions of printing/scanning>

Size: Letter (A4) Lengthwise

Centering:OFF

Auto Masking:ON

2. Check the width of the black band running around the image area.
3. Refer to the charts given below.  
Then, adjust to desired black band width by Function Mode o7.

o7		
Setting	Adjusted black band width (mm)	
d5	-6±3	<div style="display: flex; align-items: center; justify-content: center;"> <div style="writing-mode: vertical-rl; transform: rotate(180deg);">band width decreases</div> <div style="margin: 0 10px;">↑</div> <div style="writing-mode: vertical-rl; transform: rotate(180deg);">↓</div> </div>
d6	-4±3	
d7	-2±3	
d8	0±3	
d9	2±3	
dA	4±3	
db	6±3	

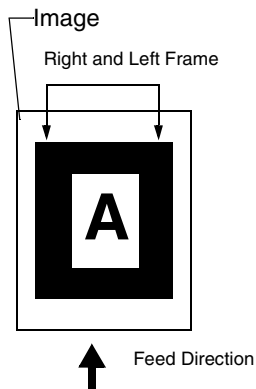



**6.7.8 o8: Projection lamp burn out detection (L2) setting**

Select whether to detect L2 when Projection Lamp burn out.

Display	setting	Function
o8	*d0 d1	Detects Not Detects

**6.7.9 oA: Host Driver Setting**

Set the Host Driver which uses at the PC mode.

Display	setting	Function
oA	*d0 d1 d2	MS 6000 MS 2000 MicroDAX (Fixed Window)

**6.7.10 ob: Vender/Model Name Setting**

Set the vender name and model name displayed in PC at the PC mode.

Display	setting	Function
ob	*d0 d1 d2	Minolta MS 6000 Minolta MS 2000 OEM Name

## 6.8 F mode Operations

### 6.8.1 F1: ROM Version Check

Used when checking the present ROM version of the machine.

1. Sets the function mode "F1", and press the Start Key.
2. Shows the current ROM version number of the machine.  
[Ex.] ROM Version "25" → "G0" → "01".....Ver.25G001

### 6.8.2 F2: Scan Counter

Used when checking the total Scan Counter.

1. Sets the function mode "F2", and press the Start Key.
2. Shows the current Scan Counter of the machine.  
[Ex.] Display "02" → "46" → "12".....24,612 count

### 6.8.3 F3: Print Counter

Used when checking the total Print Counter.

1. Sets the function mode "F3", and press the Start Key.
2. Shows the current Print Counter of the machine.  
[Ex.] Display "01" → "23" → "45".....12,345 prints

### 6.8.4 F4: Counter Clear

This mode should be used to clear the scan counter and print counter.

1. Sets the function mode "F4".
2. Press the setting mode memory key.
3. A display window blinks and counter is cleared.
4. Performs "F2" and "F3" and checks the scan counter and print counter.

### 6.8.5 F5: Control Panel LED Check

This mode should be used to light up the LEDs and check these functions.

1. Sets the function mode "F5".
2. Press the print button to light up all LEDs on the Control Panel for about 2 seconds.

### 6.8.6 F6: For Factory use

For factory adjustment. Do not use in field.

### 6.8.7 F7: Projection Lamp Voltage Adjustment

This Adjustment is made to adjust the Projection Lamp Voltage.  
This Adjustment is necessary after the replacement of the Projection Lamp Regulator (PU2).

1. Remove the Optical Cover.
2. Remove the Projection Unit.

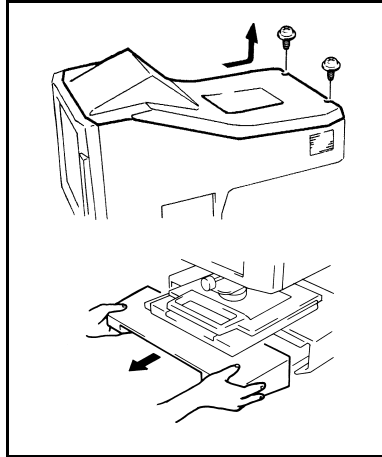

3. Insert the probes of a multi-meter into the receptacle of 2P connector locates at the right side bottom of the machine.

- (+) Test Probe: Pin 1 (Red cord)  
(-) Test Probe: Pin 2 (Green cord)

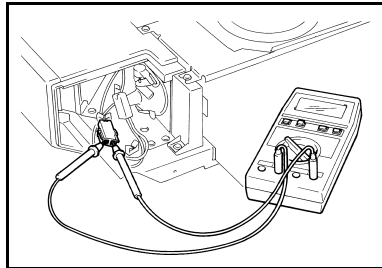

4. Turn ON the Interlock Switch (S201).
5. Connect the Power Plug with the outlet and turn ON the Power Switch.

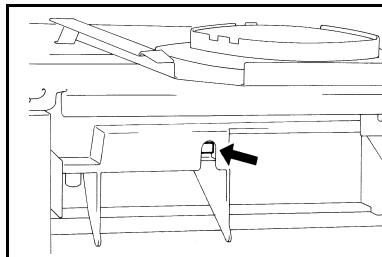

6. Referring to the setting procedure for Function mode, set "F7".
7. To perform the adjustment, press the Start key.

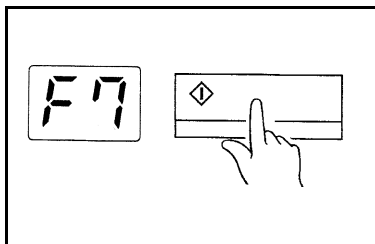

8. Rotate VR61 on PU2 so that the reading voltage on the multi-meter becomes  $DC21.5 \pm 0.2V$ .
9. Cancel the Function Mode.
10. Check the Projection Lamp voltage in reader mode is  $DC17.0 \pm 0.3V$ .

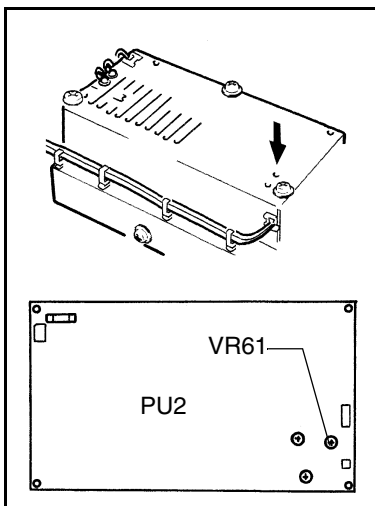

#### NOTE

In order to prevent damage of the Projection Lamp be careful of the following items in adjustment.

- Do not exceed the  $DC21.7V$  during Projection Lamp voltage adjustment.
- Makes full lighting time in F7 mode of the Projection Lamp into less than 30 seconds.

#### 6.8.8 F8: Reset the Setting Data

Function mode setting value and job program are reset to the default value.

1. Sets the function mode "F8".
2. Press the Mode Memory Key.
3. A display window blinks and setting data is cleared.

## 6.9 b mode Operations

### 6.9.1 b1: Checking the Scan Table Unit Function

This mode should be used to check the Scan Table Unit Function.

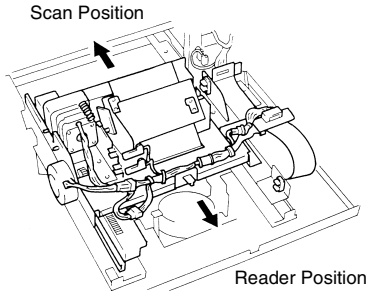

1. Referring to the setting procedure for Function mode, set "b1".
2. Press the Start Key to move the Scan Table Unit to the Scan position.
3. Press the Start Key to move the Unit to the Reader position.

### 6.9.2 b2: Scanning mirror operation check

This mode should be used to check the Scan Mirror and the Scan Motor.

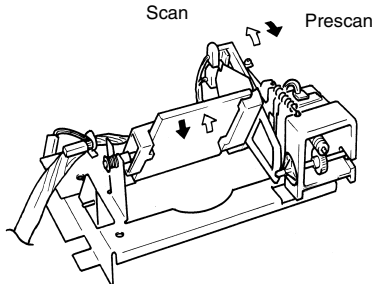

1. Referring to the setting procedure for Function mode, set "b2".
2. Press the Start key, to perform scan operation (Scan and Prescan).

### 6.9.3 b3: For Factory use

For factory adjustment. Do not use in field.

**6.9.4 b4: Prism rotation operation check**

Checks the rotation operation (AIR function) of a prism.

1. Referring to the setting procedure for Function mode, set "b4".
2. Press the Start Key to perform the 45 degree prism rotation. (The screen image rotates 90 degrees. )
3. Whenever the Start Key pressed, prism repeats 45 degree rotation (clockwise rotation and counterclockwise rotation).

**6.9.5 b5: Single scan operation check**

Checks single scan operation.

1. Referring to the setting procedure for Function mode, set "b5".
2. Press the Start Key to perform the single scan operation.
3. After the single scan operation has been completed, "b5" blinking on the Multi-print Display lights up steadily and the machine completes the operation.
4. Press the Start Key once again to perform single scan operation.

### 6.9.6 b6: Shading Correction

This adjustment is necessary after the replacement of PWB-A or PWB-BB.

1. Checks the surface of the 1st to 3rd scan path mirror and if dirty clean it.
2. Place Projection Lens TYPE 2 in position and set a lens zoom ratio of 20X.
3. Load film and bring the image into focus.  
(Do not move the focus ring after this operation).
4. Remove the Projection Lens and the Film Carrier.
5. Remove the Optical Cover and Prism from the machine.
6. Cover the entire Screen with a black sheet of paper to prevent an extraneous light from striking the Screen.
7. Turn on the Power Switch and waits for 5 minutes and stabilizes temperature of IC on PWB-A.
8. Set the function mode into "b6" and depress the Mode Memory key to perform the Shading Correction.
9. The execution time of a Shading Correction is 10 minutes from about 6 minutes.  
A Display changes as follows during Shading Correction execution.  
H1→H2→H3→.....→H9→H0→1(E1)  
When a display was set to "1" or "E1", Shading Correction was completed.  
(Displays "E1", when a printer is not connected)
10. When a Shading Correction carries out an unusual end on the way and displays "C3", perform once again from Procedure 1.
11. After Shading Correction is completed, attach the Film Carrier and Prism.

### 6.9.7 b7: Test Print Function

The test print of the printer can be executed.

1. Referring to the setting procedure for Function mode, set "b7".
2. Press the Start Key.
3. The following test prints are output by the printer.



### 6.9.8 b8: For Factory use

For factory adjustment. Do not use in field.



# 7 Troubleshooting

## 7.1 How to Use This Section

1. If a component on a P.W.Board or any other functional unit including motor is defective, the booklet only instructs you to replace the whole P.W.Board or functional unit and does not give troubleshooting procedure applicable within the defective unit.
2. All troubleshooting procedures contained herein assumes that there are no breaks in the harnesses and cords and all connectors are plugged in the right positions.
3. For the removal procedure of covers and parts, refer to the "DISASSEMBLY/CLEANING" section.
4. "GND" indicated in this booklet represents a 0-volt line of the circuit concerned, equivalent to chassis ground; however, be sure to use the Test Point (TP) on the PWB-D when creating a closed-circuit or measuring voltage.
5. The procedures are given in the order of greater frequency of occurrence of malfunctions and in the order of operation.
6. The procedures preclude possible malfunctions due to noise and other external causes.
7. Refer to the wiring diagram of Appendix for wiring of electrical parts.
8. Since this manual has not indicated the trouble of the printer, refer to the service manual of the printer.

## 7.2 Malfunction Indications

Display	Contents	Section
L2	Projection Lamp malfunction	Scanner
C1	Scan Unit Drive malfunction	
C2	Scan Mirror Drive malfunction	
C3	Shading Correction malfunction	
C4	Cooling Fan Motor malfunction	
C6	Fusing malfunction	Printer
C7	Laser Diode malfunction	
C8	Polygon Motor malfunction	
C9	Main Motor malfunction	
CA	Cooling Fan Motor malfunction	
Cb	Communication Error	Scanner or Printer
CL	Printer Clock malfunction	Scanner
PE	Paper Empty	Printer
P0	Paper Size Error	
P1	Paper Misfeed (Paper Take-up Section)	
P2	Paper Misfeed (Paper Transport Section)	
P3	Paper Misfeed (Fusing Section)	
E1	Printer Power OFF or Cable disconnect	
E2	Top Cover Open	

If the above trouble is displayed, first perform the following works.

1. Turns off the power switch, and unplug the power cord.
2. After 10 seconds or more progress, plug the power cord and turns on Power Switch.

When a trouble cannot be canceled and occurring frequently, it performs troubleshooting with reference to subsequent page.

## 7.3 Malfunction Detection Timing

### 7.3.1 L2: Projection Lamp malfunction

Display	Detection Timing
L2	When scan begins and the light of the Projection Lamp does not strike the CCD.

### 7.3.2 C1: Scan Unit Drive malfunction

Display	Detection Timing
C1	<p>The Scan Position Sensor (PC4) is not activated within 2sec. after the Scan Table has started moving to the printer position.</p>
	<p>The Reader Position Sensor (PC3) is not activated within 2sec. after the Scan Table has started moving to the reader position.</p>

### 7.3.3 C2: Scan Mirror Drive malfunction

Display	Detection Timing
C2	<p>The Scan Motor (M1) is not deenergized within 16 sec. after it has been energized during a scan motion.</p>
	<p>The Scan Motor (M1) is not deenergized within 8 sec. after it has been energized during a prescan motion.</p>



## 7.4 Troubleshooting for malfunction code

### 7.4.1 L2: Projection Lamp malfunction

Check Item		Remedy
Check LA1.	→NG	Replace LA1.
↓OK		
The carrier glass is covered by a dark colored piece of paper or some other thing that would prevent light from shining through the glass.	→Yes	Remove paper or any other obstruction from the carrier glass.
	→No	Replace PWB-A. Replace PWB-BB.

### 7.4.2 C1: Scan Unit Drive Malfunction

Check Item		Remedy
Does the Scan Table Drive Motor rotate when the Power Switch is turned ON?	→No	Wiring Check Replace the following parts. PWB-T PWB-BB M2
↓Yes		
Is C1 shown when scanning motion?	→No	OK
↓Yes		
Check PC3.	→NG	Replace PC3.
↓OK		
Check PC4.	→NG	Replace PC4.
	→OK	Replace PWB-BB.

### 7.4.3 C2: Scan Mirror Drive malfunction

Check Item		Remedy
Is C2 shown even when power is turned OFF, then ON again?	→No	OK
↓Yes		
Does the Scan Motor rotate when the Power Switch is turned ON?	→Yes	Check Wiring. Replace the following parts. PWB-T PWB-BB M1
↓No		
Check PC1.	→NG	Replace PC1.
↓OK		
Check PC2.	→NG	Replace PC2.
	→OK	Replace PWB-BB.

**7.4.4 C3: Shading Correction malfunction**

Check Item		Remedy
Is C3 displayed during Function Mode "b6" execution?	→No	Replace PWB-BB. Replace CCD Assy(PWB-A).
↓Yes		
Performs the function mode (b6) once again. (Refers to the clause of Shading Correction in chapter 6).	→NG	Replace PWB-BB. Replace CCD Assy(PWB-A).

**7.4.5 C4: Cooling Fan Motor malfunction**

Check Item		Remedy
Is C4 shown even when power is turned OFF, then ON again?	→No	OK
↓Yes		
Does the Cooling Fan Motor (M3, M4) turn smoothly after the Power Switch has been turned ON?	→Yes	Check Wiring. Replace PWB-BB.
↓No		
Check M3 and M4.	→NG	Replace M3. Replace M4.
	→OK	Check Wiring. Replace PWB-BB.

**7.4.6 Cb: Communication Error**

Check Item		Remedy
Is Cb shown even when power is turned OFF, then turned ON again?	→No	OK
↓Yes		
Is the dedicated interface cable used?	→No	Replace the Interface Cable.
↓Yes		
Checks the connection of an interface cable.	→NG	Reconnect the Interface Cable.
↓OK		
Replace the following parts sequentially. Interface Cable Printer I/F Board (PWB-EE) of Scanner Interface Board of Printer		

### 7.4.7 CL: Printer Clock malfunction

Check Item		Remedy
Is CL shown even when power is turned OFF, then turned ON again?	→No	OK
↓Yes		
Is the dedicated interface cable used?	→No	Replace the Interface Cable.
↓Yes		
Checks the connection of an interface cable.	→No	Reconnect the Interface Cable.
↓Yes		
Confirm the frequency of the Oscillator on PWB-EE.  When using the MSP3000 Printer OSC1: 42.3158MHz OSC2: 95.2106MHz  When using the MSP2000 Printer. OSC1: 19.5332MHz OSC2: None	→NG	Reinstall the Oscillator. or Replace the Oscillator.
↓OK		
Replace PWB-EE.		

## 7.5 Troubleshooting for malfunction

### 7.5.1 No Power

Check Item		Remedy
Has the Power Switch (S1) been turned ON?	→ No	Turn on the Power Switch (S1).
↓Yes		
Has the Power Cord been securely connected to the machine?	→No	Plug in the power cord.
↓Yes		
Has the Power Cord been securely plugged into the outlet?	→No	Plug the power cord into the power outlet.
↓Yes		
Is the Fuse (F1) blown?	→Yes	Replace Power Fuse (F1).
↓No		
Is the Interlock Switch (S201) in the actuated position when the Projection Unit is installed?	→No	Adjust the position of the Switch (S201).
↓Yes		
Is the Fuse of PU1 blown?	→No	Replace PU1 or S201.
	→Yes	Replace Fuse(F1) of PU1.

### 7.5.2 The Projection Lamp does not Light Up

Check Item		Remedy
Check LA1.	→ NG	Replace LA1.
↓OK		
Check TS1.	→ NG	Replace TS1.
↓OK		
Is the voltage across CN7-1 and -2 approx. DC17V when the Power ON/OFF switch is in the ON position?	→ No	Check wiring.
↓Yes		
Is the source voltage developing across PJ1-1 and -3 on PU2 when the Power ON/OFF switch is in the ON position?	→ No	Check wiring.
↓Yes		
Is the voltage across PJ3-1 on PU2 and GND DC5V when the Power ON/OFF switch is in the ON position?	→ No	Check wiring.
	→ Yes	Replace PWB-BB. Replace PU2.



## 7.6 Electrical Components Check

### 7.6.1 LA1: Projection Lamp

1	Is the circuit across both terminals of the Lamp conducting when the Lamp is removed from the machine?	→No	Replace LA1.
		→Yes	OK

### 7.6.2 M3: Power Unit Cooling Fan Motor

1	Does the Motor start rotating when the Power ON/OFF Switch is turned ON?	→Yes	OK
	↓ No		
2	Is the voltage across CN10-1 and GND DC24V with the Power Switch in the ON position?	→No	Check wiring.
		→Yes	Replace M3.

### 7.6.3 M4: Projection Lamp Cooling Fan Motor

1	Does the Motor start rotating when the Power ON/OFF Switch is turned ON?	→Yes	OK
	↓ No		
2	Is the voltage across CN18-1 and GND DC24V with the Power ON/OFF Switch in the ON position?	→No	Check wiring.
		→Yes	Replace M4.

### 7.6.4 PC1: Image Leading Edge Sensor

1	Is the voltage across PJ8-A3 on PWB-BB and GND 0V when the Power Switch is in the ON position and the light emitted by the Sensor LED is blocked?	→No	Replace PC1.
	↓ Yes		
2	Is the voltage across PJ8-A3 on PWB-BB and GND DC5V when the light emitted by the Sensor LED strikes the Sensor photosensitive element?	→No	Replace PC1.
		→Yes	OK

### 7.6.5 PC2: Scan Mirror Position Sensor

1	Is the voltage across PJ8-B15 on PWB-BB and GND 0V when the Power Switch is in the ON position and the light emitted by the Sensor LED is blocked?	→No	Replace PC2.
	↓ Yes		
2	Is the voltage across PJ8-B15 on PWB-BB and GND DC5V when the light emitted by the Sensor LED strikes the Sensor photosensitive element?	→No	Replace PC2.
		→Yes	OK

**7.6.6 PC3: Reader Position Sensor**

1	Is the voltage across PJ8-B12 on PWB-BB and GND 0V when the Power ON/OFF Switch is in the ON position and the light emitted by the Sensor LED is blocked?	→No	Replace PC3.
	↓ Yes		
2	Is the voltage across PJ8-B12 on PWB-BB and GND DC5V when the light emitted by the Sensor LED strikes the Sensor photosensitive element?	→No	Replace PC3.
		→Yes	OK

**7.6.7 PC4: Scan Position Sensor**

1	Is the voltage across PJ8-A6 on PWB-BB and GND 0V when the Power ON/OFF Switch is in the ON position and the light emitted by the Sensor LED is blocked?	→No	Replace PC4.
	↓ Yes		
2	Is the voltage across PJ8-A6 on PWB-BB and GND DC5V when the light emitted by the Sensor LED strikes the Sensor photosensitive element?	→No	Replace PC4.
		→Yes	OK

**7.6.8 PU1: Power Unit**

1	Is the Fuse of PU1 blown?	→Yes	Replace Fuse.
	↓ No		
2	Is the output voltage of each Connector correct when the Power Switch is in the ON position?	→No	Replace PU1.
		→Yes	OK

**7.6.9 PU2: Projection Lamp Regulator**

1	Is the Fuse of PU2 blown?	→Yes	Replace Fuse.
	↓ No		
2	Is the voltage across CN7-1 and CN7-2 DC17.0V when the machine is in the reader mode?	→No	Replace PU2.
		→Yes	OK

**7.6.10 S1: Power Switch**

1	Are the circuits across 1 and 2, and 3 and 4 conducting when the Power Switch is removed from the machine and in the OFF position?	→Yes	Replace S1.
	↓ No		
2	Are the circuits across 1 and 2, and 3 and 4 conducting when the Switch is in the position?	→No	Replace S1.
		→Yes	OK

### 7.6.11 S201: Interlock Switch

1	Is the circuit across COM and NC terminals conducting when the Switch is removed from the machine?	→Yes	Replace S201.
	↓ No		
2	Is the circuit across COM and NC terminals conducting when the Switch Actuator is depressed?	→No	Replace S201.
		→Yes	OK

### 7.6.12 TS1: Thermostat

1	Is the Reset Pin in the depressed position?	→No	Depress the Reset Pin.
	↓ Yes		
2	Is the circuit across both terminals of the Thermostat conducting when the Thermostat is removed from the machine?	→No	Replace TS1.
		→Yes	OK

## 7.7 Image Troubleshooting

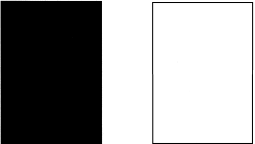
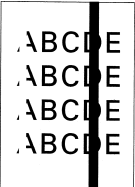
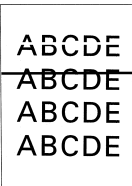
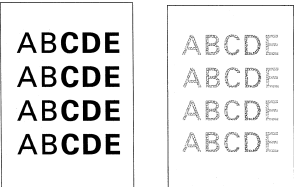
Trouble	Remedy
<p>Black or blank print</p> 	<ul style="list-style-type: none"> <li>• Check the Projection Lamp (LA1) for possible discoloration and breaks.</li> <li>• Adjust the Projection Lamp voltage (F7).</li> <li>• N-P/P-P AE Coarse adjustment (o1, o2).</li> <li>• Perform the Shading correction (b6).</li> <li>• Replace the PWB-A.</li> <li>• Replace the PWB-BB.</li> </ul>
<p>Black or white line in the feed direction</p> 	<ul style="list-style-type: none"> <li>• Clean the Scanner 1st to 3rd Mirrors.</li> <li>• Clean the CCD Cover glass.</li> <li>• Perform the Shading correction (b6).</li> <li>• Replace the PWB-A.</li> <li>• Replace the PWB-BB.</li> </ul>
<p>Black or white line in the scan direction</p> 	<ul style="list-style-type: none"> <li>• Clean the Scanner 1st to 3rd Mirrors.</li> <li>• Clean the CCD Cover glass.</li> <li>• Perform the Shading correction (b6).</li> <li>• Replace the PWB-A.</li> <li>• Replace the PWB-BB.</li> </ul>
<p>Uneven image</p> 	<ul style="list-style-type: none"> <li>• Clean the CCD Cover glass.</li> <li>• Perform the Shading correction (b6).</li> <li>• Adjust the Projection Lamp voltage (F7).</li> <li>• N-P/P-P AE Coarse adjustment (o1, o2).</li> <li>• Replace the PWB-A.</li> <li>• Replace the PWB-BB.</li> </ul>

The Image abnormalities of the printer refer to the service manual of the printer and perform the Troubleshooting.



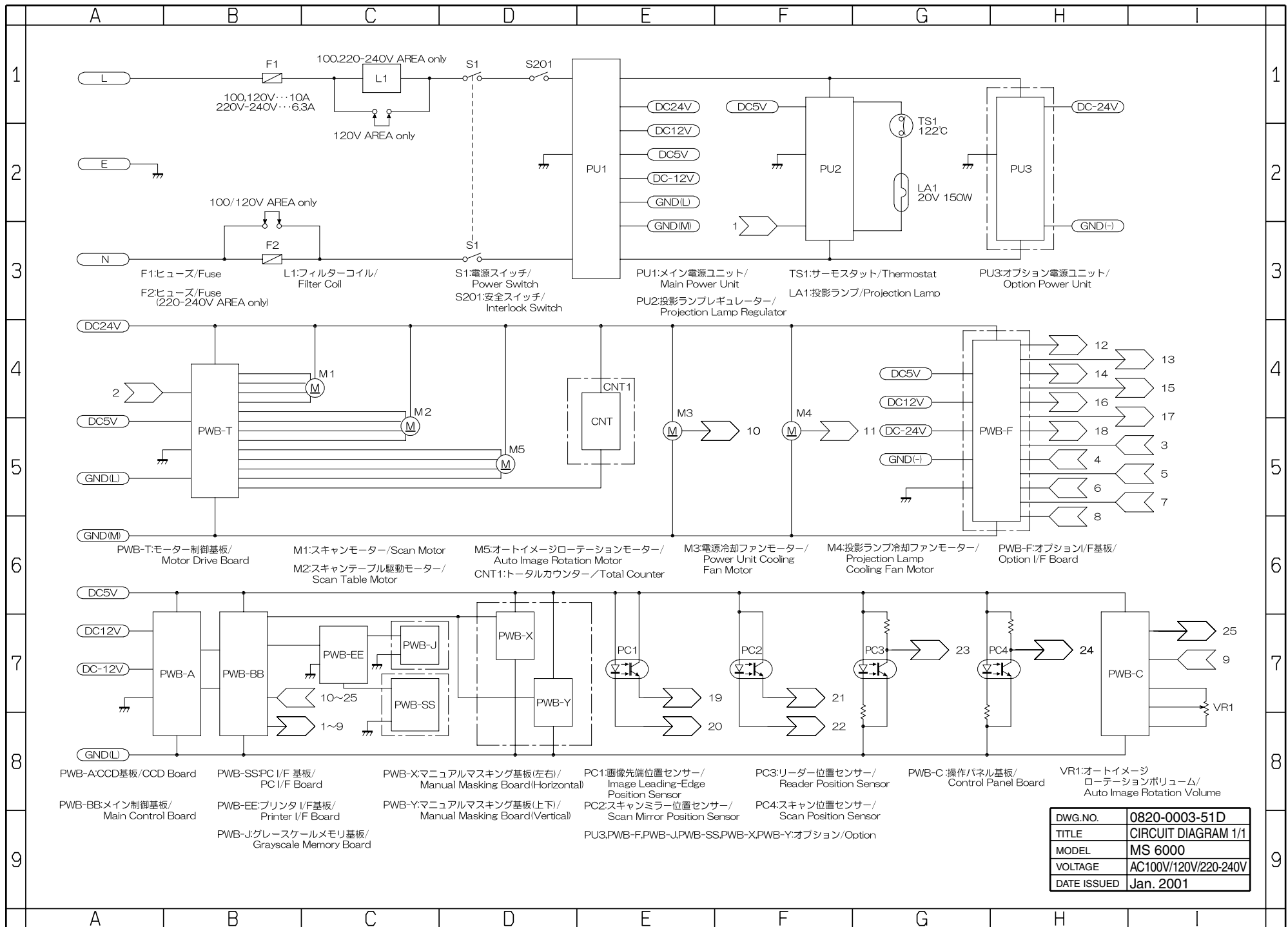

F1:ヒューズ/Fuse  
F2:ヒューズ/Fuse  
(220-240V AREA only)

L1:フィルタコイル/  
Filter Coil

S1:電源スイッチ/  
Power Switch  
S201:安全スイッチ/  
Interlock Switch

PU1:メイン電源ユニット/  
Main Power Unit  
PU2:投影ランプレギュレーター/  
Projection Lamp Regulator

TS1:サーモスタット/Thermostat  
LA1:投影ランプ/Projection Lamp

PU3:オプション電源ユニット/  
Option Power Unit

PWB-T:モーター制御基板/  
Motor Drive Board

M1:スキャンモーター/Scan Motor  
M2:スキャンテーブル駆動モーター/  
Scan Table Motor

M5:オートイメージローテーションモーター/  
Auto Image Rotation Motor  
CNT1:トータルカウンター/Total Counter

M3:電源冷却ファンモーター/  
Power Unit Cooling  
Fan Motor

M4:投影ランプ冷却ファンモーター/  
Projection Lamp  
Cooling Fan Motor

PWB-F:オプションI/F基板/  
Option I/F Board

PWB-A:CCD基板/CCD Board

PWB-SS:PC I/F 基板/  
PC I/F Board

PWB-X:マニュアルマスキング基板(左右)/  
Manual Masking Board(Horizontal)

PC1:画像先端位置センサー/  
Image Leading-Edge  
Position Sensor

PC2:スキャンミラー位置センサー/  
Scan Mirror Position Sensor

PC3:リーダー位置センサー/  
Reader Position Sensor

PWB-C:操作パネル基板/  
Control Panel Board

VR1:オートイメージ  
ローテーションボリューム/  
Auto Image Rotation Volume

PWB-BB:メイン制御基板/  
Main Control Board

PWB-EE:プリンタ I/F 基板/  
Printer I/F Board

PWB-Y:マニュアルマスキング基板(上下)/  
Manual Masking Board(Vertical)

PU3,PWB-F,PWB-J,PWB-SS,PWB-X,PWB-Y:オプション/Option

PC4:スキャン位置センサー/  
Scan Position Sensor

DWG.NO.	0820-0003-51D
TITLE	CIRCUIT DIAGRAM 1/1
MODEL	MS 6000
VOLTAGE	AC100V/120V/220-240V
DATE ISSUED	Jan. 2001

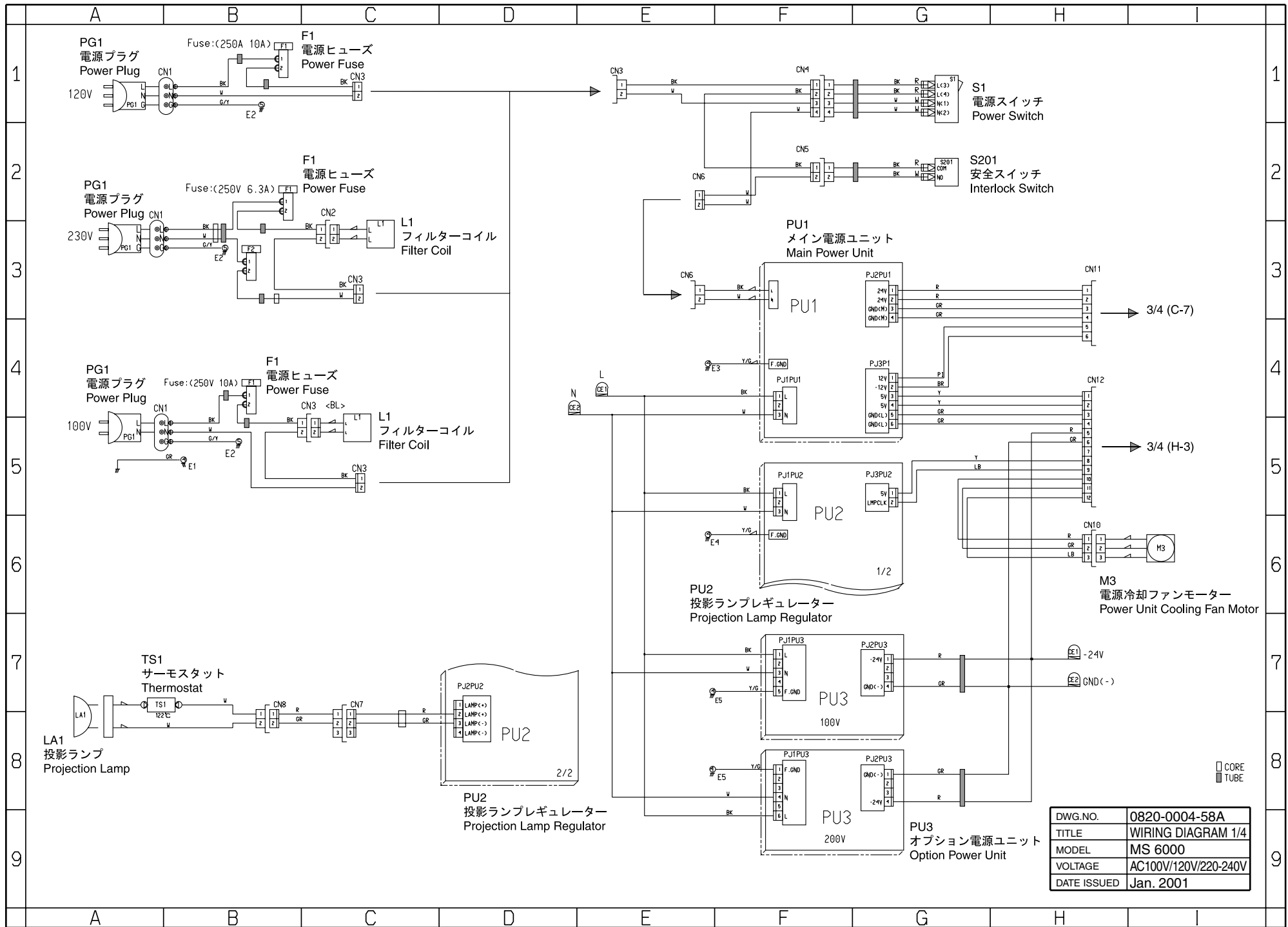

DWG.NO.	0820-0004-58A
TITLE	WIRING DIAGRAM 1/4
MODEL	MS 6000
VOLTAGE	AC100V/120V/220-240V
DATE ISSUED	Jan. 2001

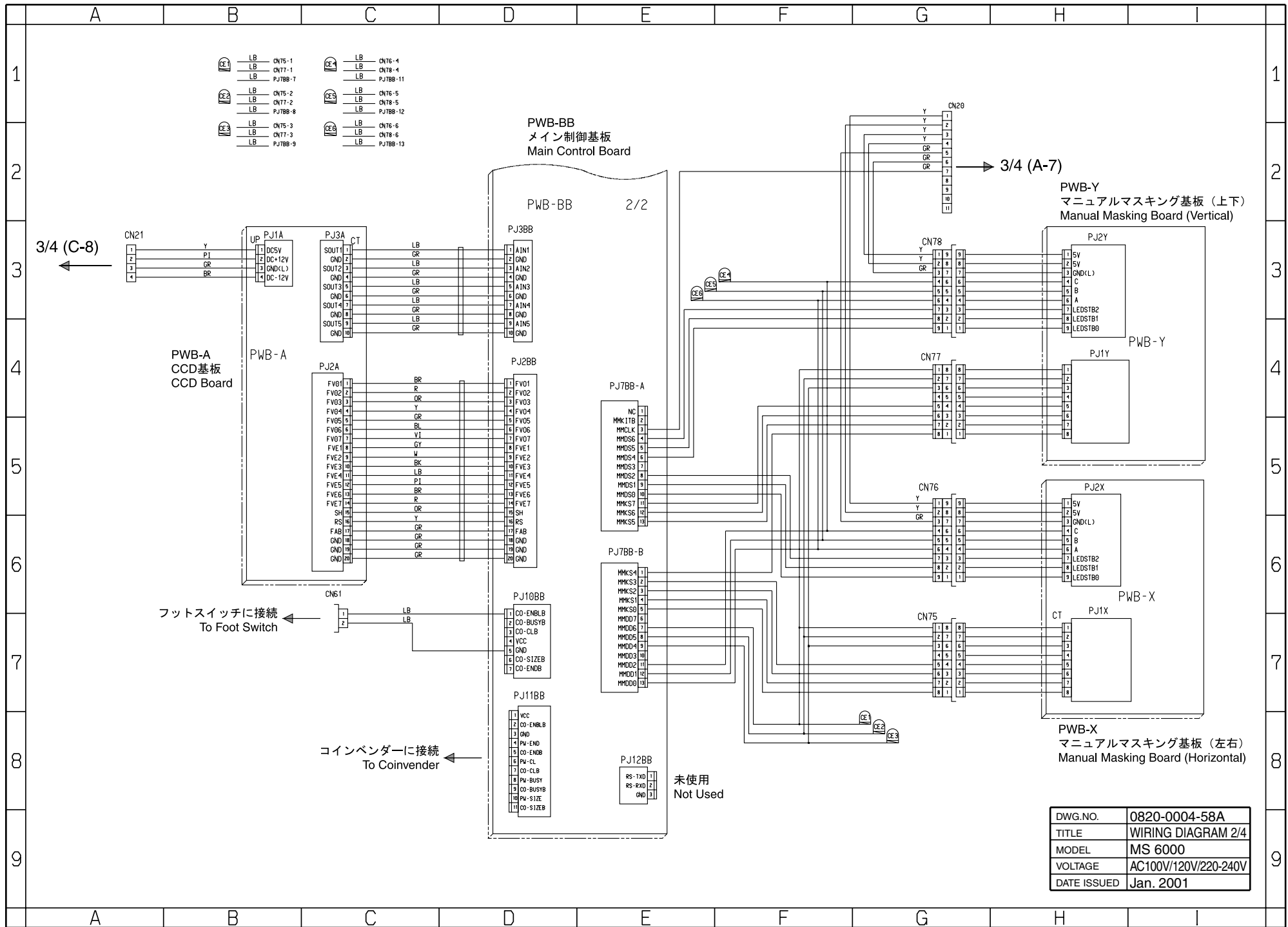

DWG.NO.	0820-0004-58A
TITLE	WIRING DIAGRAM 2/4
MODEL	MS 6000
VOLTAGE	AC100V/120V/220-240V
DATE ISSUED	Jan. 2001



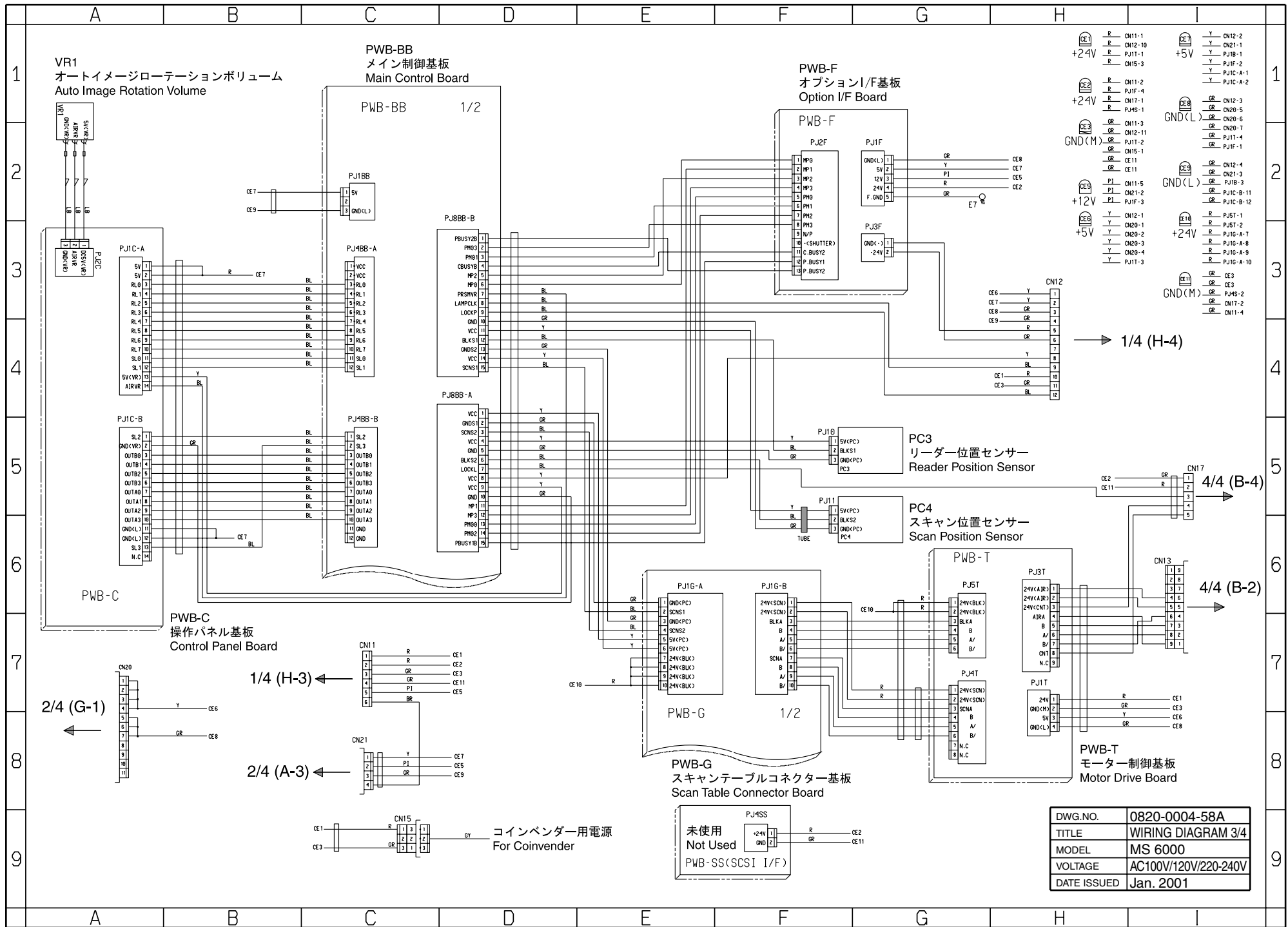

CE1	R	CN11-1	Y	CN12-2
CE2	R	CN12-10	Y	CN12-1
CE3	R	PJ11-1	Y	PJ1B-1
CE4	R	CN15-3	Y	PJ1F-2
CE5	R	CN11-2	Y	PJ1C-A-1
CE6	R	PJ1F-4	Y	PJ1C-A-2
CE7	R	CN17-1	GR	CN12-3
CE8	R	CN17-2	GR	CN20-5
CE9	R	PJ4S-1	GR	CN20-6
CE10	GR	CN11-3	GR	CN20-7
CE11	GR	CN12-11	GR	CN21-4
CE12	GR	PJ11-2	GR	PJ1F-1
CE13	GR	CN15-1	GR	CN12-4
CE14	GR	CN11	GR	CN12-3
CE15	GR	CN11	GR	PJ1B-3
CE16	GR	CN11	GR	CN20-7
CE17	GR	CN11	GR	PJ11-4
CE18	GR	CN11	GR	PJ1F-1
CE19	GR	CN11	GR	CN12-4
CE20	GR	CN11	GR	CN12-3
CE21	GR	CN11	GR	PJ1B-3
CE22	GR	CN11	GR	CN20-7
CE23	GR	CN11	GR	PJ11-4
CE24	GR	CN11	GR	PJ1F-1
CE25	GR	CN11	GR	CN12-4
CE26	GR	CN11	GR	CN12-3
CE27	GR	CN11	GR	PJ1B-3
CE28	GR	CN11	GR	CN20-7
CE29	GR	CN11	GR	PJ11-4
CE30	GR	CN11	GR	PJ1F-1
CE31	GR	CN11	GR	CN12-4
CE32	GR	CN11	GR	CN12-3
CE33	GR	CN11	GR	PJ1B-3
CE34	GR	CN11	GR	CN20-7
CE35	GR	CN11	GR	PJ11-4
CE36	GR	CN11	GR	PJ1F-1
CE37	GR	CN11	GR	CN12-4
CE38	GR	CN11	GR	CN12-3
CE39	GR	CN11	GR	PJ1B-3
CE40	GR	CN11	GR	CN20-7
CE41	GR	CN11	GR	PJ11-4
CE42	GR	CN11	GR	PJ1F-1
CE43	GR	CN11	GR	CN12-4
CE44	GR	CN11	GR	CN12-3
CE45	GR	CN11	GR	PJ1B-3
CE46	GR	CN11	GR	CN20-7
CE47	GR	CN11	GR	PJ11-4
CE48	GR	CN11	GR	PJ1F-1
CE49	GR	CN11	GR	CN12-4
CE50	GR	CN11	GR	CN12-3
CE51	GR	CN11	GR	PJ1B-3
CE52	GR	CN11	GR	CN20-7
CE53	GR	CN11	GR	PJ11-4
CE54	GR	CN11	GR	PJ1F-1
CE55	GR	CN11	GR	CN12-4
CE56	GR	CN11	GR	CN12-3
CE57	GR	CN11	GR	PJ1B-3
CE58	GR	CN11	GR	CN20-7
CE59	GR	CN11	GR	PJ11-4
CE60	GR	CN11	GR	PJ1F-1
CE61	GR	CN11	GR	CN12-4
CE62	GR	CN11	GR	CN12-3
CE63	GR	CN11	GR	PJ1B-3
CE64	GR	CN11	GR	CN20-7
CE65	GR	CN11	GR	PJ11-4
CE66	GR	CN11	GR	PJ1F-1
CE67	GR	CN11	GR	CN12-4
CE68	GR	CN11	GR	CN12-3
CE69	GR	CN11	GR	PJ1B-3
CE70	GR	CN11	GR	CN20-7
CE71	GR	CN11	GR	PJ11-4
CE72	GR	CN11	GR	PJ1F-1
CE73	GR	CN11	GR	CN12-4
CE74	GR	CN11	GR	CN12-3
CE75	GR	CN11	GR	PJ1B-3
CE76	GR	CN11	GR	CN20-7
CE77	GR	CN11	GR	PJ11-4
CE78	GR	CN11	GR	PJ1F-1
CE79	GR	CN11	GR	CN12-4
CE80	GR	CN11	GR	CN12-3
CE81	GR	CN11	GR	PJ1B-3
CE82	GR	CN11	GR	CN20-7
CE83	GR	CN11	GR	PJ11-4
CE84	GR	CN11	GR	PJ1F-1
CE85	GR	CN11	GR	CN12-4
CE86	GR	CN11	GR	CN12-3
CE87	GR	CN11	GR	PJ1B-3
CE88	GR	CN11	GR	CN20-7
CE89	GR	CN11	GR	PJ11-4
CE90	GR	CN11	GR	PJ1F-1
CE91	GR	CN11	GR	CN12-4
CE92	GR	CN11	GR	CN12-3
CE93	GR	CN11	GR	PJ1B-3
CE94	GR	CN11	GR	CN20-7
CE95	GR	CN11	GR	PJ11-4
CE96	GR	CN11	GR	PJ1F-1
CE97	GR	CN11	GR	CN12-4
CE98	GR	CN11	GR	CN12-3
CE99	GR	CN11	GR	PJ1B-3
CE100	GR	CN11	GR	CN20-7

CN1 2	Y	1	2
CE6	Y	3	3
CE7	Y	4	4
CE8	GR	5	5
CE9	GR	6	6
Y	R	7	7
GR	GR	8	8
Y	R	9	9
CE1	R	10	10
CE3	GR	11	11
Y	R	12	12

CN1 7	GR	1	1
CE2	GR	2	2
CE11	GR	3	3
Y	R	4	4
GR	GR	5	5

CN1 3	1	1	1
24V(CA)R	2	2	2
24V(CA)R	3	3	3
24V(CNT)	4	4	4
AJRA	5	5	5
B	6	6	6
A/	7	7	7
B/	8	8	8
CNT	9	9	9
N.C	10	10	10

CN1 3	R	1	1
24V	R	2	2
GND(M)	GR	3	3
5V	Y	4	4
GND(L)	GR	5	5
CE3	GR	6	6
CE1	GR	7	7
CE8	GR	8	8

DWG.NO.	0820-0004-58A
TITLE	WIRING DIAGRAM 3/4
MODEL	MS 6000
VOLTAGE	AC100V/120V/220-240V
DATE ISSUED	Jan. 2001

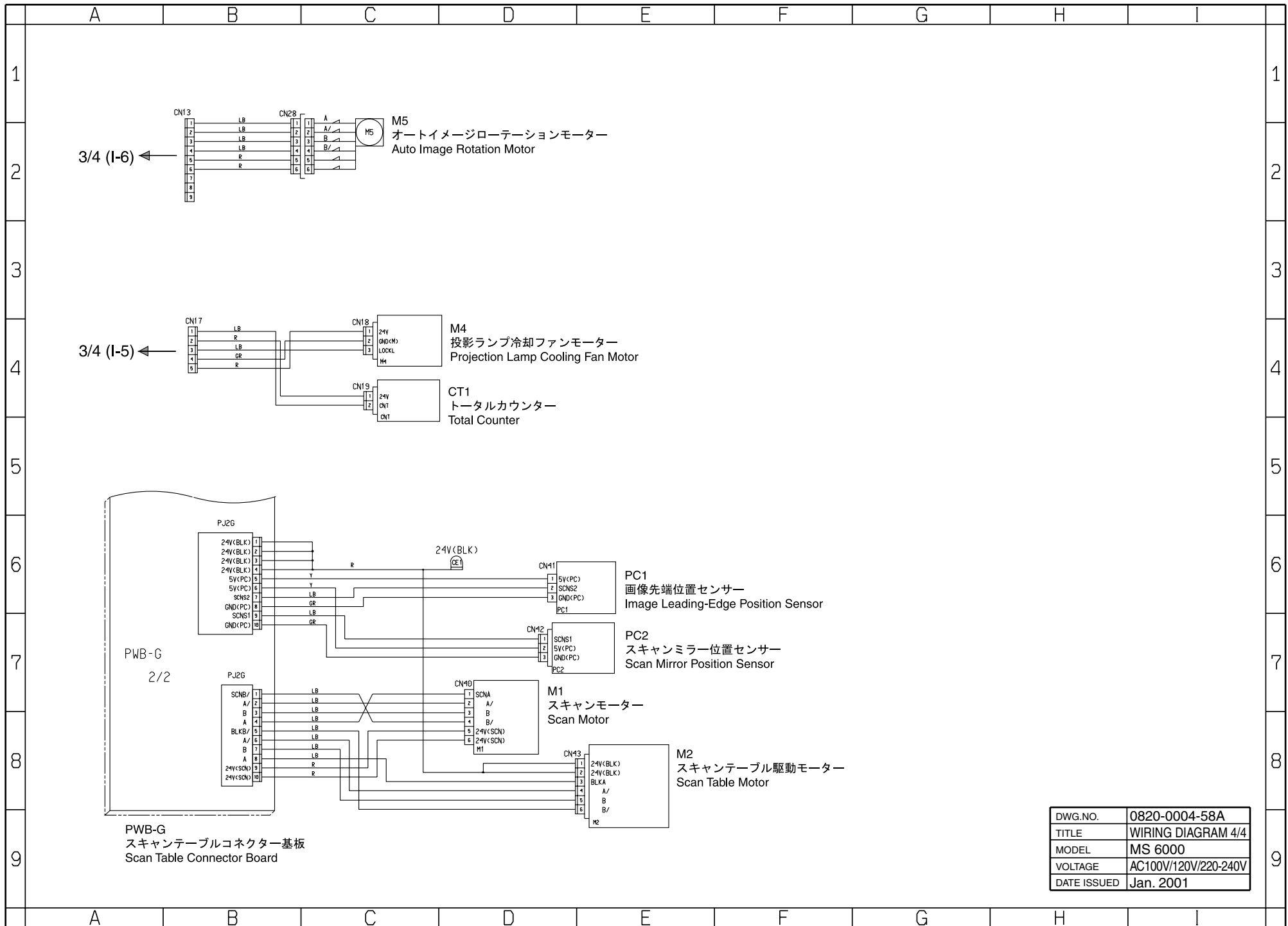

DWG.NO.	0820-0004-58A
TITLE	WIRING DIAGRAM 4/4
MODEL	MS 6000
VOLTAGE	AC100V/120V/220-240V
DATE ISSUED	Jan. 2001

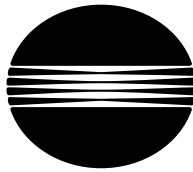

MINOLTA

*Copyright*  
*2001 MINOLTA CO.,LTD.*  
*Printed In Japan*

Use of this manual should be strictly supervised to avoid disclosure of confidential information.

This publication is printed on recycled paper.

MINOLTA CO., LTD.

0820-7993-11 01020160  
Printed in Japan

## Free Manuals Download Website

<http://myh66.com>

<http://usermanuals.us>

<http://www.somanuals.com>

<http://www.4manuals.cc>

<http://www.manual-lib.com>

<http://www.404manual.com>

<http://www.luxmanual.com>

<http://aubethermostatmanual.com>

Golf course search by state

<http://golfingnear.com>

Email search by domain

<http://emailbydomain.com>

Auto manuals search

<http://auto.somanuals.com>

TV manuals search

<http://tv.somanuals.com>