



OM-480

128 576AC

January 2005

Processes



Stick (SMAW) Welding



Air Carbon Arc (CAC-A)
Cutting And Gouging

With Optional Equipment:



Flux Cored (FCAW) With
Voltage-Sensing Wire Feeder

Description



Engine Driven Welding Generator

Big Blue™ 251D

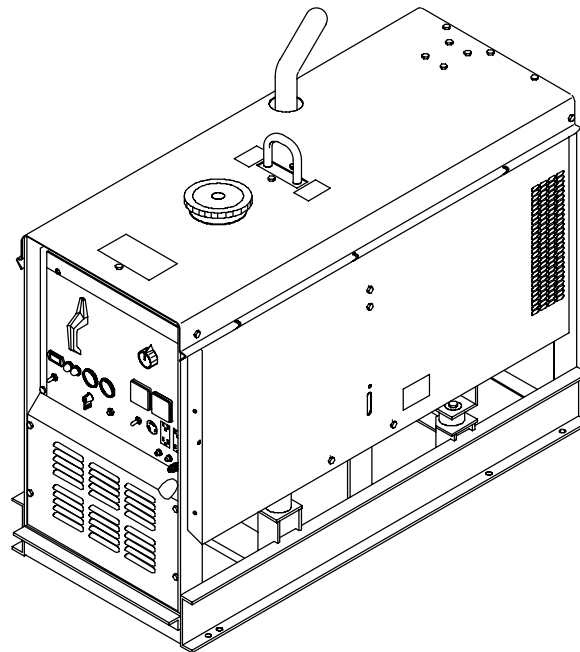

Visit our website at
www.MillerWelds.com

OWNER'S MANUAL

From Miller to You

Thank you and congratulations on choosing Miller. Now you can get the job done and get it done right. We know you don't have time to do it any other way.

That's why when Niels Miller first started building arc welders in 1929, he made sure his products offered long-lasting value and superior quality. Like you, his customers couldn't afford anything less. Miller products had to be more than the best they could be. They had to be the best you could buy.

Today, the people that build and sell Miller products continue the tradition. They're just as committed to providing equipment and service that meets the high standards of quality and value established in 1929.

This Owner's Manual is designed to help you get the most out of your Miller products. Please take time to read the Safety precautions. They will help you protect yourself against potential hazards on the worksite.

We've made installation and operation quick and easy. With Miller you can count on years of reliable service with proper maintenance. And if for some reason the unit needs repair, there's a Troubleshooting section that will help you figure out what the problem is. The parts list will then help you to decide the exact part you may need to fix the problem. Warranty and service information for your particular model are also provided.



Miller is the first welding equipment manufacturer in the U.S.A. to be registered to the ISO 9001:2000 Quality System Standard.

Miller Electric manufactures a full line of welders and welding related equipment. For information on other quality Miller products, contact your local Miller distributor to receive the latest full line catalog or individual catalog sheets. **To locate your nearest distributor or service agency call 1-800-4-A-Miller, or visit us at www.MillerWelds.com on the web.**



Working as hard as you do – every power source from Miller is backed by the most hassle-free warranty in the business.



TABLE OF CONTENTS

SECTION 1 – SAFETY PRECAUTIONS – READ BEFORE USING	1
1-1. Symbol Usage	1
1-2. Arc Welding Hazards	1
1-3. Engine Hazards	2
1-4. Compressed Air Hazards	3
1-5. Additional Symbols For Installation, Operation, And Maintenance	3
1-6. California Proposition 65 Warnings	4
1-7. Principal Safety Standards	4
1-8. EMF Information	4
SECTION 2 – CONSIGNES DE SÉCURITÉ – LIRE AVANT UTILISATION	5
2-1. Signification des symboles	5
2-2. Dangers relatifs au soudage à l'arc	5
2-3. Dangers existant en relation avec le moteur	6
2-4. Dangers liés à l'air comprimé	7
2-5. Dangers supplémentaires en relation avec l'installation, le fonctionnement et la maintenance	7
2-6. Principales normes de sécurité	8
2-7. Information sur les champs électromagnétiques	8
SECTION 3 – DEFINITIONS	9
3-1. Symbols And Definitions	9
SECTION 4 – SPECIFICATIONS	10
4-1. Weld, Power, And Engine Specifications	10
4-2. Dimensions, Weights, And Operating Angles	10
4-3. Fuel Consumption	11
4-4. Duty Cycle And Overheating	11
4-5. AC Generator Power	12
4-6. Volt-Ampere Curves	12
4-7. Optional AC Power Plant Curves	13
SECTION 5 – INSTALLATION	14
5-1. Installing Welding Generator	14
5-2. Connecting The Battery	14
5-3. Installing Muffler Pipe	15
5-4. Engine Prestart Checks	15
5-5. Installing Ether Cylinder (Optional Ether Starting Aid)	16
5-6. Connecting To Weld Output Terminals	16
5-7. Selecting Weld Cable Sizes*	17
SECTION 6 – OPERATING THE WELDING GENERATOR	18
6-1. Controls (See Section 6-2)	18
6-2. Description Of Front Panel Controls (See Section 6-1)	19
6-3. Remote A/V Control	19
SECTION 7 – OPERATING AUXILIARY EQUIPMENT	20
7-1. 120 Volt Duplex And Optional GFCI Receptacles	20
7-2. 240 Volt Duplex Receptacle (Optional)	21
7-3. Connecting Optional AC Power Plant	22
7-4. 120/240 Volt Twistlock Receptacle (Optional)	23

TABLE OF CONTENTS

SECTION 8 – MAINTENANCE AND TROUBLESHOOTING	24
8-1. Routine Maintenance	24
8-2. Maintenance Label	25
8-3. Servicing Air Cleaner	26
8-4. Servicing Fuel And Lubrication Systems	27
8-5. Adjusting Engine Speed	28
8-6. Overload Protection	29
8-7. Servicing Optional Ether Starting Aid	29
8-8. Inspecting And Cleaning Optional Spark Arrestor	30
8-9. Troubleshooting	30
SECTION 9 – ELECTRICAL DIAGRAM	32
SECTION 10 – RUN-IN PROCEDURE	33
10-1. Wetstacking	33
10-2. Run-In Procedure Using Load Bank	34
10-3. Run-In Procedure Using Resistance Grid	35
SECTION 11 – GENERATOR POWER GUIDELINES	36
SECTION 12 – PARTS LIST	44
OPTIONS AND ACCESSORIES	
WARRANTY	

SECTION 1 – SAFETY PRECAUTIONS – READ BEFORE USING

rom_nd_8/03

▲ **Warning: Protect yourself and others from injury — read and follow these precautions.**

1-1. Symbol Usage



Means Warning! Watch Out! There are possible hazards with this procedure! The possible hazards are shown in the adjoining symbols.

▲ Marks a special safety message.

☞ Means "Note"; not safety related.



This group of symbols means Warning! Watch Out! possible ELECTRIC SHOCK, MOVING PARTS, and HOT PARTS hazards. Consult symbols and related instructions below for necessary actions to avoid the hazards.

1-2. Arc Welding Hazards

▲ **The symbols shown below are used throughout this manual to call attention to and identify possible hazards. When you see the symbol, watch out, and follow the related instructions to avoid the hazard. The safety information given below is only a summary of the more complete safety information found in the Safety Standards listed in Section 1-7. Read and follow all Safety Standards.**

▲ **Only qualified persons should install, operate, maintain, and repair this unit.**

▲ **During operation, keep everybody, especially children, away.**



ELECTRIC SHOCK can kill.

Touching live electrical parts can cause fatal shocks or severe burns. The electrode and work circuit is electrically live whenever the output is on. The input power circuit and machine internal circuits are also live when power is on. In semiautomatic or automatic wire welding, the wire, wire reel, drive roll housing, and all metal parts touching the welding wire are electrically live. Incorrectly installed or improperly grounded equipment is a hazard.

- Do not touch live electrical parts.
- Wear dry, hole-free insulating gloves and body protection.
- Insulate yourself from work and ground using dry insulating mats or covers big enough to prevent any physical contact with the work or ground.
- Do not use AC output in damp areas, if movement is confined, or if there is a danger of falling.
- Use AC output ONLY if required for the welding process.
- If AC output is required, use remote output control if present on unit.
- Additional safety precautions are required when any of the following electrically hazardous conditions are present: in damp locations or while wearing wet clothing; on metal structures such as floors, gratings, or scaffolds; when in cramped positions such as sitting, kneeling, or lying; or when there is a high risk of unavoidable or accidental contact with the workpiece or ground. For these conditions, use the following equipment in order presented: 1) a semiautomatic DC constant voltage (wire) welder, 2) a DC manual (stick) welder, or 3) an AC welder with reduced open-circuit voltage. In most situations, use of a DC, constant voltage wire welder is recommended. And, do not work alone!
- Disconnect input power or stop engine before installing or servicing this equipment. Lockout/tagout input power according to OSHA 29 CFR 1910.147 (see Safety Standards).
- Properly install and ground this equipment according to its Owner's Manual and national, state, and local codes.
- Always verify the supply ground — check and be sure that input power cord ground wire is properly connected to ground terminal in disconnect box or that cord plug is connected to a properly grounded receptacle outlet.
- When making input connections, attach proper grounding conductor first — double-check connections.
- Frequently inspect input power cord for damage or bare wiring — replace cord immediately if damaged — bare wiring can kill.
- Turn off all equipment when not in use.
- Do not use worn, damaged, undersized, or poorly spliced cables.
- Do not drape cables over your body.
- If earth grounding of the workpiece is required, ground it directly with a separate cable.
- Do not touch electrode if you are in contact with the work, ground, or another electrode from a different machine.

- Use only well-maintained equipment. Repair or replace damaged parts at once. Maintain unit according to manual.
- Wear a safety harness if working above floor level.
- Keep all panels and covers securely in place.
- Clamp work cable with good metal-to-metal contact to workpiece or worktable as near the weld as practical.
- Insulate work clamp when not connected to workpiece to prevent contact with any metal object.
- Do not connect more than one electrode or work cable to any single weld output terminal.

SIGNIFICANT DC VOLTAGE exists in inverters after stopping engine.

- Stop engine on inverter and discharge input capacitors according to instructions in Maintenance Section before touching any parts.

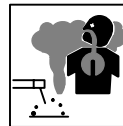

FUMES AND GASES can be hazardous.

Welding produces fumes and gases. Breathing these fumes and gases can be hazardous to your health.

- Keep your head out of the fumes. Do not breathe the fumes.
- If inside, ventilate the area and/or use exhaust at the arc to remove welding fumes and gases.
- If ventilation is poor, use an approved air-supplied respirator.
- Read the Material Safety Data Sheets (MSDSs) and the manufacturer's instructions for metals, consumables, coatings, cleaners, and degreasers.
- Work in a confined space only if it is well ventilated, or while wearing an air-supplied respirator. Always have a trained watchperson nearby. Welding fumes and gases can displace air and lower the oxygen level causing injury or death. Be sure the breathing air is safe.
- Do not weld in locations near degreasing, cleaning, or spraying operations. The heat and rays of the arc can react with vapors to form highly toxic and irritating gases.
- Do not weld on coated metals, such as galvanized, lead, or cadmium plated steel, unless the coating is removed from the weld area, the area is well ventilated, and if necessary, while wearing an air-supplied respirator. The coatings and any metals containing these elements can give off toxic fumes if welded.



BUILDUP OF GAS can injure or kill.

- Shut off shielding gas supply when not in use.
- Always ventilate confined spaces or use approved air-supplied respirator.

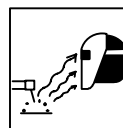

ARC RAYS can burn eyes and skin.

Arc rays from the welding process produce intense visible and invisible (ultraviolet and infrared) rays that can burn eyes and skin. Sparks fly off from the weld.

- Wear a welding helmet fitted with a proper shade of filter to protect your face and eyes from arc rays and sparks when welding or watching (see ANSI Z49.1 and Z87.1 listed in Safety Standards).
- Wear approved safety glasses with side shields under your helmet.
- Use protective screens or barriers to protect others from flash and glare; warn others not to watch the arc.
- Wear protective clothing made from durable, flame-resistant material (wool and leather) and foot protection.



WELDING can cause fire or explosion.

Welding on closed containers, such as tanks, drums, or pipes, can cause them to blow up. Sparks can fly off from the welding arc. The flying sparks, hot workpiece, and hot equipment can cause fires and burns. Accidental contact of electrode to metal objects can cause sparks, explosion, overheating, or fire. Check and be sure the area is safe before doing any welding.

- Protect yourself and others from flying sparks and hot metal.
- Do not weld where flying sparks can strike flammable material.
- Remove all flammables within 35 ft (10.7 m) of the welding arc. If this is not possible, tightly cover them with approved covers.
- Be alert that welding sparks and hot materials from welding can easily go through small cracks and openings to adjacent areas.
- Watch for fire, and keep a fire extinguisher nearby.
- Be aware that welding on a ceiling, floor, bulkhead, or partition can cause fire on the hidden side.
- Do not weld on closed containers such as tanks, drums, or pipes, unless they are properly prepared according to AWS F4.1 (see Safety Standards).
- Connect work cable to the work as close to the welding area as practical to prevent welding current from traveling long, possibly unknown paths and causing electric shock and fire hazards.
- Do not use welder to thaw frozen pipes.
- Remove stick electrode from holder or cut off welding wire at contact tip when not in use.
- Wear oil-free protective garments such as leather gloves, heavy shirt, cuffless trousers, high shoes, and a cap.
- Remove any combustibles, such as a butane lighter or matches, from your person before doing any welding.
- Follow requirements in OSHA 1910.252 (a) (2) (iv) and NFPA 51B for hot work and have a fire watcher and extinguisher nearby.

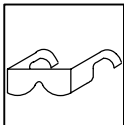

FLYING METAL can injure eyes.

- Welding, chipping, wire brushing, and grinding cause sparks and flying metal. As welds cool, they can throw off slag.
- Wear approved safety glasses with side shields even under your welding helmet.

1-3. Engine Hazards



BATTERY EXPLOSION can BLIND.

- Always wear a face shield, rubber gloves, and protective clothing when working on a battery.
- Stop engine before disconnecting or connecting battery cables or servicing battery.
- Do not allow tools to cause sparks when working on a battery.
- Do not use welder to charge batteries or jump start vehicles.
- Observe correct polarity (+ and -) on batteries.
- Disconnect negative (-) cable first and connect it last.



FUEL can cause fire or explosion.

- Stop engine and let it cool off before checking or adding fuel.
- Do not add fuel while smoking or if unit is near any sparks or open flames.
- Do not overfill tank — allow room for fuel to expand.
- Do not spill fuel. If fuel is spilled, clean up before starting engine.
- Dispose of rags in a fireproof container.
- Always keep nozzle in contact with tank when fueling.



HOT PARTS can cause severe burns.

- Allow cooling period before maintaining.
- Wear protective gloves and clothing when working on a hot engine.
- Do not touch hot engine parts or just-welded parts bare-handed.

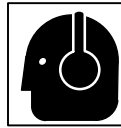

NOISE can damage hearing.

Noise from some processes or equipment can damage hearing.

- Wear approved ear protection if noise level is high.



MAGNETIC FIELDS can affect pacemakers.

- Pacemaker wearers keep away.
- Wearers should consult their doctor before going near arc welding, gouging, or spot welding operations.



CYLINDERS can explode if damaged.

Shielding gas cylinders contain gas under high pressure. If damaged, a cylinder can explode. Since gas cylinders are normally part of the welding process, be sure to treat them carefully.

- Protect compressed gas cylinders from excessive heat, mechanical shocks, slag, open flames, sparks, and arcs.
- Install cylinders in an upright position by securing to a stationary support or cylinder rack to prevent falling or tipping.
- Keep cylinders away from any welding or other electrical circuits.
- Never drape a welding torch over a gas cylinder.
- Never allow a welding electrode to touch any cylinder.
- Never weld on a pressurized cylinder — explosion will result.
- Use only correct shielding gas cylinders, regulators, hoses, and fittings designed for the specific application; maintain them and associated parts in good condition.
- Turn face away from valve outlet when opening cylinder valve.
- Keep protective cap in place over valve except when cylinder is in use or connected for use.
- Read and follow instructions on compressed gas cylinders, associated equipment, and CGA publication P-1 listed in Safety Standards.



MOVING PARTS can cause injury.

- Keep away from fans, belts, and rotors.
- Keep all doors, panels, covers, and guards closed and securely in place.
- Stop engine before installing or connecting unit.
- Have only qualified people remove guards or covers for maintenance and troubleshooting as necessary.
- To prevent accidental starting during servicing, disconnect negative (-) battery cable from battery.
- Keep hands, hair, loose clothing, and tools away from moving parts.
- Reinstall panels or guards and close doors when servicing is finished and before starting engine.
- Before working on generator, remove spark plugs or injectors to keep engine from kicking back or starting.
- Block flywheel so that it will not turn while working on generator components.



STEAM AND HOT COOLANT can burn.

- If possible, check coolant level when engine is cold to avoid scalding.
- Always check coolant level at overflow tank, if present on unit, instead of radiator (unless told otherwise in maintenance section or engine manual).
- If the engine is warm, checking is needed, and there is no overflow tank, follow the next two statements.
- Wear safety glasses and gloves and put a rag over radiator cap.
- Turn cap slightly and let pressure escape slowly before completely removing cap.



ENGINE EXHAUST GASES can kill.

- Use equipment outside in open, well-ventilated areas.
- If used in a closed area, vent engine exhaust outside and away from any building air intakes.

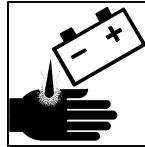

BATTERY ACID can BURN SKIN and EYES.

- Do not tip battery.
- Replace damaged battery.
- Flush eyes and skin immediately with water.

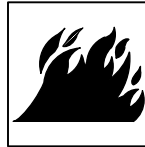

ENGINE HEAT can cause fire.

- Do not locate unit on, over, or near combustible surfaces or flammables.
- Keep exhaust and exhaust pipes way from flammables.



EXHAUST SPARKS can cause fire.

- Do not let engine exhaust sparks cause fire.
- Use approved engine exhaust spark arrestor in required areas — see applicable codes.

1-4. Compressed Air Hazards



BREATHING COMPRESSED AIR can cause serious injury or death.

- Do not use compressed air for breathing.
- Use only for cutting, gouging, and tools.

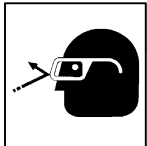

COMPRESSED AIR can cause injury.

- Wear approved safety goggles.
- Do not direct air stream toward self or others.



TRAPPED AIR PRESSURE AND WHIPPING HOSES can cause injury.

- Release air pressure from tools and system before servicing, adding or changing attachments, or opening compressor oil drain or oil fill cap.



HOT METAL from air arc cutting and gouging can cause fire or explosion.

- Do not cut or gouge near flammables.
- Watch for fire; keep extinguisher nearby.



HOT PARTS can cause burns and injury.

- Do not touch hot compressor or air system parts.
- Let system cool down before touching or servicing.

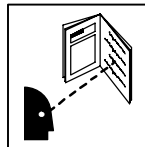

READ INSTRUCTIONS.

- Read Owner's Manual before using or servicing unit.
- Stop engine and release air pressure before servicing.

1-5. Additional Symbols For Installation, Operation, And Maintenance



FALLING UNIT can cause injury.

- Use lifting eye to lift unit only, NOT running gear, gas cylinders, trailer, or any other accessories.
- Use equipment of adequate capacity to lift and support unit.
- If using lift forks to move unit, be sure forks are long enough to extend beyond opposite side of unit.

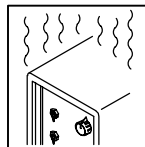

OVERUSE can cause OVERHEATING.

- Allow cooling period; follow rated duty cycle.
- Reduce current or reduce duty cycle before starting to weld again.
- Do not block or filter airflow to unit.

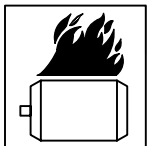

OVERHEATING can damage motors.

- Turn off or unplug equipment before starting or stopping engine.
- Do not let low voltage and frequency caused by low engine speed damage electric motors.
- Do not connect 50 or 60 Hertz motors to the 100 Hertz receptacle where applicable.

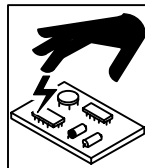

STATIC (ESD) can damage PC boards.

- Put on grounded wrist strap BEFORE handling boards or parts.
- Use proper static-proof bags and boxes to store, move, or ship PC boards.

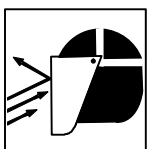

FLYING SPARKS can cause injury.

- Wear a face shield to protect eyes and face.
- Shape tungsten electrode only on grinder with proper guards in a safe location wearing proper face, hand, and body protection.
- Sparks can cause fires — keep flammables away.



TILTING OF TRAILER can cause injury.

- Use tongue jack or blocks to support weight.
- Properly install welding generator onto trailer according to instructions supplied with trailer.

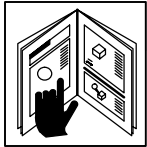

READ INSTRUCTIONS.

- Use only genuine MILLER/Hobart replacement parts.
- Perform engine and air compressor (if applicable) maintenance and service according to this manual and the engine/air compressor (if applicable) manuals.

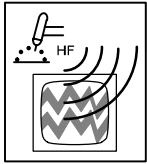

H.F. RADIATION can cause interference.

- High-frequency (H.F.) can interfere with radio navigation, safety services, computers, and communications equipment.
- Have only qualified persons familiar with electronic equipment perform this installation.
- The user is responsible for having a qualified electrician promptly correct any interference problem resulting from the installation.
- If notified by the FCC about interference, stop using the equipment at once.
- Have the installation regularly checked and maintained.
- Keep high-frequency source doors and panels tightly shut, keep spark gaps at correct setting, and use grounding and shielding to minimize the possibility of interference.

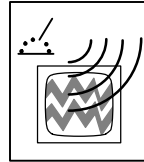

ARC WELDING can cause interference.

- Electromagnetic energy can interfere with sensitive electronic equipment such as microprocessors, computers, and computer-driven equipment such as robots.
- Be sure all equipment in the welding area is electromagnetically compatible.
- To reduce possible interference, keep weld cables as short as possible, close together, and down low, such as on the floor.
- Locate welding operation 100 meters from any sensitive electronic equipment.
- Be sure this welding machine is installed and grounded according to this manual.
- If interference still occurs, the user must take extra measures such as moving the welding machine, using shielded cables, using line filters, or shielding the work area.

1-6. California Proposition 65 Warnings

- ▲ **Welding or cutting equipment produces fumes or gases which contain chemicals known to the State of California to cause birth defects and, in some cases, cancer. (California Health & Safety Code Section 25249.5 et seq.)**
- ▲ **Battery posts, terminals and related accessories contain lead and lead compounds, chemicals known to the State of California to cause cancer and birth defects or other reproductive harm. Wash hands after handling.**

For Gasoline Engines:

- ▲ **Engine exhaust contains chemicals known to the State of California to cause cancer, birth defects, or other reproductive harm.**

For Diesel Engines:

- ▲ **Diesel engine exhaust and some of its constituents are known to the State of California to cause cancer, birth defects, and other reproductive harm.**

1-7. Principal Safety Standards

Safety in Welding, Cutting, and Allied Processes, ANSI Standard Z49.1, from American Welding Society, 550 N.W. LeJeune Rd, Miami FL 33126 (phone: 305-443-9353, website: www.aws.org).

Recommended Safe Practices for the Preparation for Welding and Cutting of Containers and Piping, American Welding Society Standard AWS F4.1, from American Welding Society, 550 N.W. LeJeune Rd, Miami, FL 33126 (phone: 305-443-9353, website: www.aws.org).

National Electrical Code, NFPA Standard 70, from National Fire Protection Association, P.O. Box 9101, 1 Battery March Park, Quincy, MA 02269-9101 (phone: 617-770-3000, website: www.nfpa.org and www.sparky.org).

Safe Handling of Compressed Gases in Cylinders, CGA Pamphlet P-1, from Compressed Gas Association, 1735 Jefferson Davis Highway, Suite 1004, Arlington, VA 22202-4102 (phone: 703-412-0900, website: www.cganet.com).

Code for Safety in Welding and Cutting, CSA Standard W117.2, from Canadian Standards Association, Standards Sales, 178 Rexdale Bou-

levard, Rexdale, Ontario, Canada M9W 1R3 (phone: 800-463-6727 or in Toronto 416-747-4044, website: www.csa-international.org).

Practice For Occupational And Educational Eye And Face Protection, ANSI Standard Z87.1, from American National Standards Institute, 11 West 42nd Street, New York, NY 10036-8002 (phone: 212-642-4900, website: www.ansi.org).

Standard for Fire Prevention During Welding, Cutting, and Other Hot Work, NFPA Standard 51B, from National Fire Protection Association, P.O. Box 9101, 1 Battery March Park, Quincy, MA 02269-9101 (phone: 617-770-3000, website: www.nfpa.org and www.sparky.org).

OSHA, Occupational Safety and Health Standards for General Industry, Title 29, Code of Federal Regulations (CFR), Part 1910, Subpart Q, and Part 1926, Subpart J, from U.S. Government Printing Office, Superintendent of Documents, P.O. Box 371954, Pittsburgh, PA 15250 (there are 10 Regional Offices—phone for Region 5, Chicago, is 312-353-2220, website: www.osha.gov).

1-8. EMF Information

Considerations About Welding And The Effects Of Low Frequency Electric And Magnetic Fields

Welding current, as it flows through welding cables, will cause electromagnetic fields. There has been and still is some concern about such fields. However, after examining more than 500 studies spanning 17 years of research, a special blue ribbon committee of the National Research Council concluded that: "The body of evidence, in the committee's judgment, has not demonstrated that exposure to power-frequency electric and magnetic fields is a human-health hazard." However, studies are still going forth and evidence continues to be examined. Until the final conclusions of the research are reached, you may wish to minimize your exposure to electromagnetic fields when welding or cutting.

To reduce magnetic fields in the workplace, use the following procedures:

1. Keep cables close together by twisting or taping them.
2. Arrange cables to one side and away from the operator.
3. Do not coil or drape cables around your body.
4. Keep welding power source and cables as far away from operator as practical.
5. Connect work clamp to workpiece as close to the weld as possible.

About Pacemakers:

Pacemaker wearers consult your doctor first. If cleared by your doctor, then following the above procedures is recommended.

SECTION 2 – CONSIGNES DE SÉCURITÉ – LIRE AVANT UTILISATION

rom_fre 8/03

▲ Avertissement: Protégez vous et les autres des blessures – lisez et suivez ces précautions.

2-1. Signification des symboles



Signifie Mise en garde ! Soyez vigilant ! Cette procédure présente des risques de danger ! Ceux-ci sont identifiés par des symboles adjacents aux directives.

▲ Identifie un message de sécurité particulier.

Signifie NOTA ; n'est pas relatif à la sécurité.



Ce groupe de symboles signifie Mise en garde ! Soyez vigilant ! Il y a des risques de danger reliés

aux CHOCs ÉLECTRIQUES, aux PIÈCES EN MOUVEMENT et aux PIÈCES CHAUDES. Reportez-vous aux symboles et aux directives ci-dessous afin de connaître les mesures à prendre pour éviter tout danger.

2-2. Dangers relatifs au soudage à l'arc

▲ Les symboles présentés ci-après sont utilisés tout au long du présent manuel pour attirer votre attention et identifier les risques de danger. Lorsque vous voyez un symbole, soyez vigilant et suivez les directives mentionnées afin d'éviter tout danger. Les consignes de sécurité présentées ci-après ne font que résumer l'information contenue dans les normes de sécurité énumérées à la section 2-6. Veuillez lire et respecter toutes ces normes de sécurité.

▲ L'installation, l'utilisation, l'entretien et les réparations ne doivent être confiés qu'à des personnes qualifiées.

▲ Au cours de l'utilisation, tenir toute personne à l'écart et plus particulièrement les enfants.



UN CHOC ÉLECTRIQUE peut tuer.

Un simple contact avec des pièces électriques peut provoquer une électrocution ou des blessures graves. L'électrode et le circuit de soudage sont sous tension dès que l'appareil est sur ON. Le circuit d'entrée et les circuits internes de l'appareil sont également sous tension à ce moment-là. En soudage semi-automatique ou automatique, le logement des galets d'entraînement et les pièces métalliques en contact avec le fil de soudage sont sous tension. Des matériels mal installés ou mal mis à la terre présentent un danger.

- Ne jamais toucher les pièces électriques sous tension.
- Porter des gants et des vêtements de protection secs ne comportant pas de trous.
- S'isoler de la pièce et de la terre au moyen de tapis ou d'autres moyens isolants suffisamment grands pour empêcher le contact physique éventuel avec la pièce ou la terre.
- Ne pas se servir de source électrique à courant électrique dans les zones humides, dans des endroits confinés ou là où on risque de tomber.
- Se servir d'une source électrique à courant électrique UNIQUEMENT si le procédé de soudage le demande.
- Si l'utilisation d'une source électrique à courant électrique s'avère nécessaire, se servir de la fonction de télécommande si l'appareil en est équipé.
- Des précautions de sécurité supplémentaires sont requises dans des environnements à risque comme: les endroits humides ou lorsque l'on porte des vêtements mouillés; sur des structures métalliques au sol, grillages et échafaudages; dans des positions assises, à genoux et allongées; ou quand il y a un risque important de contact accidentel avec la pièce ou le sol. Dans ces cas utiliser les appareils suivants dans l'ordre de préférence: 1) un poste à souder DC semi-automatique de type CV (MIG/MAG), 2) un poste à souder manuel (électrode enrobée) DC, 3) un poste à souder manuel AC avec tension à vide réduite. Dans la plupart des cas, un poste courant continu de type CV est recommandé. Et, ne pas travailler seul!
- Couper l'alimentation ou arrêter le moteur avant de procéder à l'installation, à la réparation ou à l'entretien de l'appareil. Déverrouiller l'alimentation selon la norme OSHA 29 CFR 1910.147 (voir normes de sécurité).
- Installer et mettre à la terre correctement cet appareil conformément à son manuel d'utilisation et aux codes nationaux, provinciaux et municipaux.
- Toujours vérifier la terre du cordon d'alimentation – Vérifier et s'assurer que le fil de terre du cordon d'alimentation est bien raccordé à la borne de terre du sectionneur ou que la fiche du cordon est raccordée à une prise correctement mise à la terre.

- En effectuant les raccordements d'entrée fixer d'abord le conducteur de mise à la terre approprié et contre-vérifier les connexions.
- Vérifier fréquemment le cordon d'alimentation pour voir s'il n'est pas endommagé ou dénudé – remplacer le cordon immédiatement s'il est endommagé – un câble dénudé peut provoquer une électrocution.
- Mettre l'appareil hors tension quand on ne l'utilise pas.
- Ne pas utiliser des câbles usés, endommagés, de grosseur insuffisante ou mal épissés.
- Ne pas enrouler les câbles autour du corps.
- Si la pièce soudée doit être mise à la terre, le faire directement avec un câble distinct – ne pas utiliser le connecteur de pièce ou le câble de retour.
- Ne pas toucher l'électrode quand on est en contact avec la pièce, la terre ou une électrode provenant d'une autre machine.
- N'utiliser qu'un matériel en bon état. Réparer ou remplacer sur-le-champ les pièces endommagées. Entretien l'appareil conformément à ce manuel.
- Porter un harnais de sécurité quand on travaille en hauteur.
- Maintenir solidement en place tous les panneaux et capots.
- Fixer le câble de retour de façon à obtenir un bon contact métal-métal avec la pièce à souder ou la table de travail, le plus près possible de la soudure.
- Isoler la pince de masse quand pas mis à la pièce pour éviter le contact avec tout objet métallique.

Une tension DC importante subsiste à l'intérieur des onduleurs après avoir coupé l'alimentation.

- Couper l'alimentation du poste et décharger les condensateurs d'entrée comme indiqué dans la Section Maintenance avant de toucher des composants.

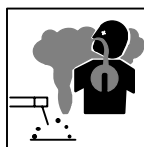

LES FUMÉES ET LES GAZ peuvent être dangereux.

Le soudage génère des fumées et des gaz. Leur inhalation peut être dangereuse pour votre santé.

- Eloigner votre tête des fumées. Ne pas respirer les fumées.
- À l'intérieur, ventiler la zone et/ou utiliser un échappement au niveau de l'arc pour l'évacuation des fumées et des gaz de soudage.
- Si la ventilation est insuffisante, utiliser un respirateur à alimentation d'air homologué.
- Lire les spécifications de sécurité des matériaux (MSDSs) et les instructions du fabricant concernant les métaux, les consommables, les revêtements, les nettoyeurs et les dégraisseurs.
- Travailler dans un espace fermé seulement s'il est bien ventilé ou en portant un respirateur à alimentation d'air. Demander toujours à un surveillant dûment formé de se tenir à proximité. Des fumées et des gaz de soudage peuvent déplacer l'air et abaisser le niveau d'oxygène provoquant des blessures ou des accidents mortels. S'assurer que l'air de respiration ne présente aucun danger.
- Ne pas souder dans des endroits situés à proximité d'opérations de dégraissage, de nettoyage ou de pulvérisation. La chaleur et les rayons de l'arc peuvent réagir en présence de vapeurs et former des gaz hautement toxiques et irritants.
- Ne pas souder des métaux munis d'un revêtement, tels que l'acier galvanisé, plaqué en plomb ou au cadmium à moins que le revêtement n'ait été enlevé dans la zone de soudure, que l'endroit soit bien ventilé, et si nécessaire, en portant un respirateur à alimentation d'air. Les revêtements et tous les métaux renfermant ces éléments peuvent dégager des fumées toxiques en cas de soudage.



LES ACCUMULATIONS DE GAZ risquent de provoquer des blessures ou même la mort.

- Fermer l'alimentation du gaz protecteur en cas de non utilisation.
- Veiller toujours à bien aérer les espaces confinés ou se servir d'un respirateur d'adduction d'air homologué.



LES RAYONS DE L'ARC peuvent provoquer des brûlures dans les yeux et sur la peau.

Le rayonnement de l'arc du procédé de soudage génère des rayons visibles et invisibles intenses (ultraviolets et infrarouges) susceptibles de provoquer des brûlures dans les yeux et sur la peau. Des étincelles sont projetées pendant le soudage.

- Porter un casque de soudage muni d'un écran de filtre approprié pour protéger votre visage et vos yeux pendant le soudage ou pour regarder (voir ANSI Z49.1 et Z87.1 énuméré dans les normes de sécurité).
- Porter des protections approuvés pour les oreilles si le niveau sonore est trop élevé.
- Utiliser des écrans ou des barrières pour protéger des tiers de l'éclair et de l'éblouissement; demander aux autres personnes de ne pas regarder l'arc.
- Porter des vêtements de protection constitué dans une matière durable, résistant au feu (laine ou cuir) et une protection des pieds.



LE SOUDAGE peut provoquer un incendie ou une explosion.

Le soudage effectué sur des conteneurs fermés tels que des réservoirs, tambours ou des conduites peut provoquer leur éclatement. Des étincelles peuvent être projetées de l'arc de soudure. La projection d'étincelles, des pièces chaudes et des équipements chauds peut provoquer des incendies et des brûlures. Le contact accidentel de l'électrode avec des objets métalliques peut provoquer des étincelles, une explosion, un surchauffement ou un incendie. Avant de commencer le soudage, vérifier et s'assurer que l'endroit ne présente pas de danger.

- Se protéger et d'autres personnes de la projection d'étincelles et de métal chaud.
- Ne pas souder dans un endroit là où des étincelles peuvent tomber sur des substances inflammables.
- Déplacer toutes les substances inflammables à une distance de 10,7 m de l'arc de soudage. En cas d'impossibilité les recouvrir soigneusement avec des protections homologués.
- Des étincelles et des matériaux chauds du soudage peuvent facilement passer dans d'autres zones en traversant de petites fissures et des ouvertures.
- Surveiller tout déclenchement d'incendie et tenir un extincteur à proximité.
- Le soudage effectué sur un plafond, plancher, paroi ou séparation peut déclencher un incendie de l'autre côté.
- Ne pas effectuer le soudage sur des conteneurs fermés tels que des réservoirs, tambours, ou conduites, à moins qu'ils n'aient été préparés correctement conformément à AWS F4.1 (voir les normes de sécurité).
- Brancher le câble sur la pièce le plus près possible de la zone de soudage pour éviter le transport du courant sur une longue distance par des chemins inconnus éventuels en provoquant des risques d'électrocution et d'incendie.
- Ne pas utiliser le poste de soudage pour dégeler des conduites gelées.
- En cas de non utilisation, enlever la baguette d'électrode du porte-électrode ou couper le fil à la pointe de contact.
- Porter des vêtements de protection dépourvus d'huile tels que des gants en cuir, une chemise en matériau lourd, des pantalons sans revers, des chaussures hautes et un couvre chef.
- Avant de souder, retirer toute substance combustible de vos poches telles qu'un allumeur au butane ou des allumettes.

2-3. Dangers existant en relation avec le moteur



LES ACCUMULATIONS DE GAZ risquent de provoquer des blessures ou même la mort.

- Fermer l'alimentation du gaz protecteur en cas de non utilisation.
- Veiller toujours à bien aérer les espaces confinés ou se servir d'un respirateur d'adduction d'air homologué.

- Suivre les recommandations dans OSHA 1910.252(a)(2)(iv) et NFPA 51B pour les travaux à chaud et avoir de la surveillance et un extincteur à proximité.

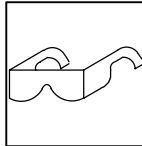

DES PARTICULES VOLANTES peuvent blesser les yeux.

- Le soudage, l'écaillage, le passage de la pièce à la brosse en fil de fer, et le meulage génèrent des étincelles et des particules métalliques volantes. Pendant la période de refroidissement des soudures, elles risquent de projeter du laitier.

- Porter des lunettes de sécurité avec écrans latéraux ou un écran facial.



DES PIÈCES CHAUDES peuvent provoquer des brûlures graves.

- Prévoir une période de refroidissement avant d'effectuer des travaux d'entretien.
- Porter des gants et des vêtements de protection pour travailler sur un moteur chaud.

- Ne pas toucher à mains nues les parties chaudes du moteur ni les pièces récemment soudées.

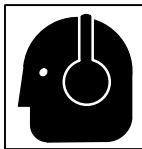

LE BRUIT peut affecter l'ouïe.

Le bruit des processus et des équipements peut affecter l'ouïe.

- Porter des protections approuvés pour les oreilles si le niveau sonore est trop élevé.

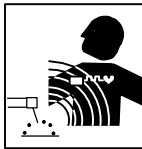

LES CHAMPS MAGNÉTIQUES peuvent affecter les stimulateurs cardiaques.

- Porteurs de stimulateur cardiaque, restez à distance.
- Les porteurs d'un stimulateur cardiaque doivent d'abord consulter leur médecin avant de s'approcher des opérations de soudage à l'arc, de gougeage ou de soudage par points.

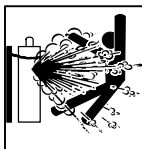

Si des BOUTEILLES sont endommagées, elles pourront exploser.

Des bouteilles de gaz protecteur contiennent du gaz sous haute pression. Si une bouteille est endommagée, elle peut exploser. Du fait que les bouteilles de gaz font normalement partie du procédé de soudage, les manipuler avec précaution.

- Protéger les bouteilles de gaz comprimé d'une chaleur excessive, des chocs mécaniques, du laitier, des flammes ouvertes, des étincelles et des arcs.
- Placer les bouteilles debout en les fixant dans un support stationnaire ou dans un porte-bouteilles pour les empêcher de tomber ou de se renverser.
- Tenir les bouteilles éloignées des circuits de soudage ou autres circuits électriques.
- Ne jamais placer une torche de soudage sur une bouteille à gaz.
- Une électrode de soudage ne doit jamais entrer en contact avec une bouteille.
- Ne jamais souder une bouteille pressurisée – risque d'explosion.
- Utiliser seulement des bouteilles de gaz protecteur, régulateurs, tuyaux et raccords convenables pour cette application spécifique; les maintenir ainsi que les éléments associés en bon état.
- Ne pas tenir la tête en face de la sortie en ouvrant la soupape de la bouteille.
- Maintenir le chapeau de protection sur la soupape, sauf en cas d'utilisation ou de branchement de la bouteille.
- Lire et suivre les instructions concernant les bouteilles de gaz comprimé, les équipements associés et les publication P-1 CGA énumérées dans les normes de sécurité.



L'ACIDE DE LA BATTERIE peut provoquer des brûlures dans les YEUX et sur la PEAU.

- Ne pas renverser la batterie.
- Remplacer une batterie endommagée.
- Rincer immédiatement les yeux et la peau à l'eau.



L'EXPLOSION DE LA BATTERIE peut RENDRE AVEUGLE.

- Toujours porter une protection faciale, des gants en caoutchouc et vêtements de protection lors d'une intervention sur la batterie.

- Arrêter le moteur avant de débrancher ou de brancher les câbles de batterie.
- Eviter de provoquer des étincelles avec les outils en travaillant sur la batterie.
- Ne pas utiliser le poste de soudage pour charger les batteries ou des véhicules de démarrage rapide.
- Observer la polarité correcte (+ et -) sur les batteries.
- Débrancher le câble négatif (-) en premier lieu. Le rebrancher en dernier lieu.



LE CARBURANT MOTEUR peut provoquer un incendie ou une explosion.

- Arrêter le moteur avant de vérifier le niveau de carburant ou de faire le plein.
- Ne pas faire le plein en fumant ou proche d'une source d'étincelles ou d'une flamme nue.

- Ne pas faire le plein de carburant à ras bord; prévoir de l'espace pour son expansion.
- Faire attention de ne pas renverser de carburant. Nettoyer tout carburant renversé avant de faire démarrer le moteur.
- Jeter les chiffons dans un récipient ignifuge.



DES ORGANES MOBILES peuvent provoquer des blessures.

- Ne pas approcher les mains des ventilateurs, courroies et autres pièces en mouvement.
- Maintenir fermés et fixement en place les portes, panneaux, recouvrements et dispositifs de protection.

- Arrêter le moteur avant d'installer ou brancher l'appareil.
- Demander seulement à un personnel qualifié d'enlever les dispositifs de sécurité ou les recouvrements pour effectuer, s'il y a lieu, des travaux d'entretien et de dépannage.

- Pour empêcher tout démarrage accidentel pendant les travaux d'entretien, débrancher le câble négatif (-) de batterie de la borne.
- Ne pas approcher les mains, cheveux, vêtements lâches et outils des organes mobiles.
- Remettre en place les panneaux ou les dispositifs de protection et fermer les portes à la fin des travaux d'entretien et avant de faire démarrer le moteur.
- Avant d'intervenir, déposer les bougies ou injecteurs pour éviter la mise en route accidentelle du moteur.
- Bloquer le volant moteur pour éviter sa rotation lors d'une intervention sur le générateur.

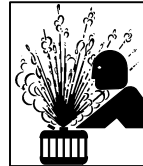

LA VAPEUR ET LE LIQUIDE DE REFROIDISSEMENT CHAUD peuvent provoquer des brûlures.

- Il est préférable de vérifier le liquide de refroidissement une fois le moteur refroidi pour éviter de se brûler.

- Toujours vérifier le niveau de liquide de refroidissement dans le vase d'expansion (si présent), et non dans le radiateur (sauf si précisé autrement dans la section maintenance du manuel du moteur).
- Si le moteur est chaud et que le liquide doit être vérifié, opérer comme suivant :
- Mettre des lunettes de sécurité et des gants, placer un torchon sur le bouchon du radiateur.
- Dévisser le bouchon légèrement et laisser la vapeur s'échapper avant d'enlever le bouchon.



LA CHALEUR DU MOTEUR peut provoquer un incendie.

- Ne pas placer l'appareil sur, au-dessus ou à proximité de surfaces inflammables.
- Tenir à distance les produits inflammables de l'échappement.



LES ÉTINCELLES À L'ÉCHAPPEMENT peuvent provoquer un incendie.

- Empêcher les étincelles d'échappement du moteur de provoquer un incendie.
- Utiliser uniquement un pare-étincelles approuvé - voir codes en vigueur.

2-4. Dangers liés à l'air comprimé



RESPIRER L'AIR COMPRIMÉ peut provoquer des blessures graves ou causer la mort.

- Ne pas utiliser l'air comprimé pour respirer.
- Utiliser l'air comprimé seulement pour le coupage, gougeage et les outils pneumatiques.

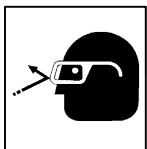

L'AIR COMPRIMÉ peut provoquer des blessures.

- Porter des lunettes de sécurité approuvées.
- Ne pas diriger le jet d'air vers d'autres ou soi-même.

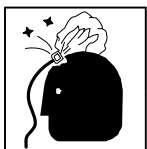

L'AIR COMPRIMÉ EMMAGASINE ET DES TUYAUX SOUS PRESSION peuvent provoquer des blessures.

- Relâcher la pression d'air de l'outillage ou du système avant d'effectuer la maintenance, avant de changer ou de rajouter des éléments ou avant d'ouvrir la purge ou le bouchon de remplissage d'huile.



Le METAL CHAUD lors du coupage et gougeage plasma peut provoquer un incendie ou une explosion.

- Ne pas couper ou gouger à proximité de produits inflammables.
- Surveillez et garder un extincteur à proximité.



DES PIÈCES CHAUDES peuvent provoquer des brûlures et blessures.

- Ne pas toucher le compresseur ou d'autres éléments du circuit air comprimé chauds.
- Laisser l'ensemble se refroidir avant de toucher ou d'effectuer la maintenance.

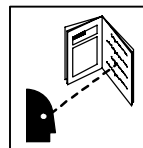

LIRE LES INSTRUCTIONS.

- Lisez le manuel d'instructions avant l'utilisation ou la maintenance de l'appareil.
- Arrêter le moteur et relâcher la pression avant d'effectuer la maintenance.

2-5. Dangers supplémentaires en relation avec l'installation, le fonctionnement et la maintenance



LA CHUTE DE L'APPAREIL peut blesser.

- Utiliser l'anneau de levage uniquement pour soulever l'appareil lui-même ; sans chariot, de bouteilles de gaz, remorque, ou autres accessoires.

- Utiliser un équipement de levage de capacité suffisante pour lever l'appareil.
- En utilisant des fourches de levage pour déplacer l'unité, s'assurer que les fourches sont suffisamment longues pour dépasser du côté opposé de l'appareil.



LE SURCHAUFFEMENT peut endommager le moteur électrique.

- Arrêter ou déconnecter l'équipement avant de démarrer ou d'arrêter le moteur.
- Ne pas laisser tourner le moteur trop lentement sous risque d'endommager le moteur électrique à cause d'une tension et d'une fréquence trop faibles.
- Ne pas brancher de moteur de 50 ou de 60 Hz à la prise de 100 Hz, s'il y a lieu.

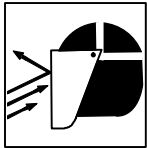

LES ÉTINCELLES VOLANTES risquent de provoquer des blessures.

- Porter un écran facial pour protéger le visage et les yeux.
- Affûter l'électrode au tungstène uniquement à la meuleuse dotée de protecteurs. Cette manoeuvre est à exécuter dans un endroit sûr lorsque l'on porte l'équipement homologué de protection du visage, des mains et du corps.
- Les étincelles risquent de causer un incendie – éloigner toute substance inflammable.

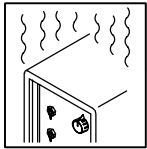

L'EMPLOI EXCESSIF peut SURCHAUFFER L'ÉQUIPEMENT.

- Laisser l'équipement refroidir ; respecter le facteur de marche nominal.
- Réduire le courant ou le facteur de marche avant de poursuivre le soudage.
- Ne pas obstruer les passages d'air du poste.

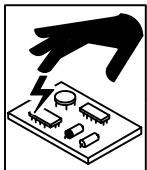

LES CHARGES ÉLECTROSTATIQUES peuvent endommager les circuits imprimés.

- Établir la connexion avec la barrette de terre avant de manipuler des cartes ou des pièces.
- Utiliser des pochettes et des boîtes antistatiques pour stocker, déplacer ou expédier des cartes de circuits imprimés.



UNE REMORQUE QUI BASCULE peut entraîner des blessures.

- Utiliser les supports de la remorque ou des blocs pour soutenir le poids.
- Installer convenablement le poste sur la remorque comme indiqué dans le manuel s'y rapportant.

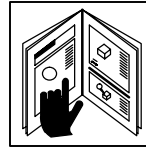

LIRE LES INSTRUCTIONS.

- Utiliser seulement les pièces de rechange d'origine.
- Effectuer la maintenance du moteur et du compresseur (si applicable) suivant ce manuel et le manuel du moteur/compresseur (si applicable).

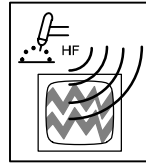

LE RAYONNEMENT HAUTE FRÉQUENCE (H.F.) risque de provoquer des interférences.

- Le rayonnement haute fréquence (H.F.) peut provoquer des interférences avec les équipements de radio-navigation et de communication, les services de sécurité et les ordinateurs.
- Demander seulement à des personnes qualifiées familiarisées avec des équipements électroniques de faire fonctionner l'installation.
- L'utilisateur est tenu de faire corriger rapidement par un électricien qualifié les interférences résultant de l'installation.
- Si le FCC signale des interférences, arrêter immédiatement l'appareil.
- Effectuer régulièrement le contrôle et l'entretien de l'installation.
- Maintenir soigneusement fermés les portes et les panneaux des sources de haute fréquence, maintenir les éclateurs à une distance correcte et utiliser une terre et un blindage pour réduire les interférences éventuelles.

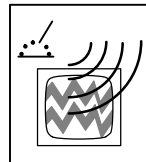

LE SOUDAGE À L'ARC risque de provoquer des interférences.

- L'énergie électromagnétique risque de provoquer des interférences pour l'équipement électronique sensible tel que les ordinateurs et l'équipement commandé par ordinateur tel que les robots.
- Veiller à ce que tout l'équipement de la zone de soudage soit compatible électromagnétiquement.
- Pour réduire la possibilité d'interférence, maintenir les câbles de soudage aussi courts que possible, les grouper, et les poser aussi bas que possible (ex. par terre).
- Veiller à souder à une distance de 100 mètres de tout équipement électronique sensible.
- Veiller à ce que ce poste de soudage soit posé et mis à la terre conformément à ce mode d'emploi.
- En cas d'interférences après avoir pris les mesures précédentes, il incombe à l'utilisateur de prendre des mesures supplémentaires telles que le déplacement du poste, l'utilisation de câbles blindés, l'utilisation de filtres de ligne ou la pose de protecteurs dans la zone de travail.

2-6. Principales normes de sécurité

Safety in Welding, Cutting, and Allied Processes, norme ANSI Z49.1, de l'American Welding Society, 550 N.W. LeJeune Rd, Miami FL 33126 (téléphone : (305) 443-9353, site Web : www.aws.org).

Recommended Safe Practices for the Preparation for Welding and Cutting of Containers and Piping, norme American Welding Society AWS F4.1, de l'American Welding Society, 550 N.W. LeJeune Rd, Miami, FL 33126 (téléphone : (305) 443-9353, site Web : www.aws.org).

National Electrical Code, norme NFPA 70, de la National Fire Protection Association, P.O. Box 9101, 1 Battery March Park, Quincy, MA 02269-9101 (téléphone : (617) 770-3000, sites Web : www.nfpa.org et www.sparky.org).

Safe Handling of Compressed Gases in Cylinders, brochure CGA P-1, de la Compressed Gas Association, 1735 Jefferson Davis Highway, Suite 1004, Arlington, VA 22202-4102 (téléphone : (703) 412-0900, site Web : www.cganet.com).

Code for Safety in Welding and Cutting, norme CSA W117.2, de la Canadian Standards Association, Standards Sales, 178 boulevard Rexdale,

Rexdale (Ontario) Canada M9W 1R3 (téléphone : (800) 463-6727 ou à Toronto : (416) 747-4044, site Web : www.csa-international.org).

Practice For Occupational And Educational Eye And Face Protection, norme ANSI Z87.1, de l'American National Standards Institute, 11 West 42nd Street, New York, NY 10036-8002 (téléphone : (212) 642-4900, site Web : www.ansi.org).

Standard for Fire Prevention During Welding, Cutting, and Other Hot Work, norme NFPA 51B, de la National Fire Protection Association, P.O. Box 9101, 1 Battery March Park, Quincy, MA 02269-9101 (téléphone : (617) 770-3000, site Web : www.nfpa.org et www.sparky.org).

OSHA, Occupational Safety and Health Standards for General Industry, Title 29, Code of Federal Regulations (CFR), Part 1910, Subpart Q, and Part 1926, Subpart J, de l'U.S. Government Printing Office, Superintendent of Documents, P.O. Box 371954, Pittsburgh, PA 15250 (il y a 10 bureaux régionaux – Téléphone pour la Région 5, Chicago : (312) 353-2220, site Web : www.osha.gov).

2-7. Information sur les champs électromagnétiques

Données sur le soudage électrique et les effets des champs magnétiques basse fréquence sur l'organisme

En parcourant les câbles de soudage, le courant crée des champs électromagnétiques. Les effets potentiels de tels champs restent préoccupants. Cependant, après avoir examiné plus de 500 études qui ont été faites pendant une période de recherche de 17 ans, un comité de spécialistes du National Research Council a conclu : « L'accumulation de preuves n'a pas démontré que l'exposition aux champs magnétiques et aux champs électriques à haute fréquence constitue un risque pour la santé humaine ». Toutefois, les études et l'examen des preuves se poursuivent. En attendant les conclusions finales de la recherche, il serait souhaitable de réduire l'exposition aux champs électromagnétiques pendant le soudage ou le coupage.

Afin de réduire les champs électromagnétiques en milieu de travail, respecter les consignes suivantes :

1. Garder les câbles ensemble en les torsadant ou en les fixant avec du ruban adhésif.
2. Mettre tous les câbles du côté opposé à l'opérateur.
3. Ne pas s'enrouler les câbles autour du corps.
4. Garder le poste de soudage et les câbles le plus loin possible de soi.
5. Placer la pince de masse le plus près possible de la zone de soudage.

Consignes relatives aux stimulateurs cardiaques :

Les personnes qui portent un stimulateur cardiaque doivent avant tout consulter leur médecin. Si ce dernier les déclare aptes, il leur est recommandé de respecter les consignes ci-dessus.

SECTION 3 – DEFINITIONS

3-1. Symbols And Definitions

	Stop Engine		Fast (Run, Weld/Power)		Slow (Idle)		Start Engine
	Fast/Slow (Run/Idle)		Battery (Engine)		Circuit Breaker		Engine Oil
	Check Injectors/Pump		Check Valve Clearance		Fuel		Protective Earth (Ground)
	Positive		Negative		Certified/Trained Mechanic		Welding Arc
	Amperes		Volts		Panel/Local		Remote
	Read Operator's Manual		Engine		Temperature		Output
	Alternating Current		Time		Hours		Seconds
	Do Not Switch While Welding		Single Phase		Three Phase		Ether Starting Aid
	Engine Coolant Temperature						

SECTION 4 – SPECIFICATIONS

4-1. Weld, Power, And Engine Specifications

Rated Welding Output	Amperage Range	Maximum Open-Circuit Voltage DC (Nominal)	Generator Power Rating	Engine	Fuel Capacity
250 A, 40 Volts DC, 100% Duty Cycle	40 – 400	95 (90)	Single-Phase, 3 kVA/kW, 26 A, 120 V AC, 60 Hz	Deutz F3L-1011 Air/Oil-Cooled, Three-Cylinder, 29 HP Diesel Engine	11.3 gal (42.8 L)

4-2. Dimensions, Weights, And Operating Angles

Dimensions	
Height	40-1/2 in (1029 mm)
Width	24-5/8 in (625 mm)
Depth	56 in (1422 mm)
A	23-1/4 in (591 mm)
B	24-5/8 in (625 mm)
C	11/16 in (17 mm)
D	2-7/8 in (73 mm)
E	4-1/2 in (114 mm)
F	22-9/16 in (573 mm)
G	27 in (686 mm)
H	30-3/8 in (772 mm)
J	41-1/4 in (1048 mm)
K	51-1/8 in (1299 mm)
L	54 in (1372 mm)
M	21/32 in (16.7 mm) Dia. 4 Holes
N	1/2 in (12.7 mm) Dia. 10 Holes
Weight	
1475 lb (670 kg)	

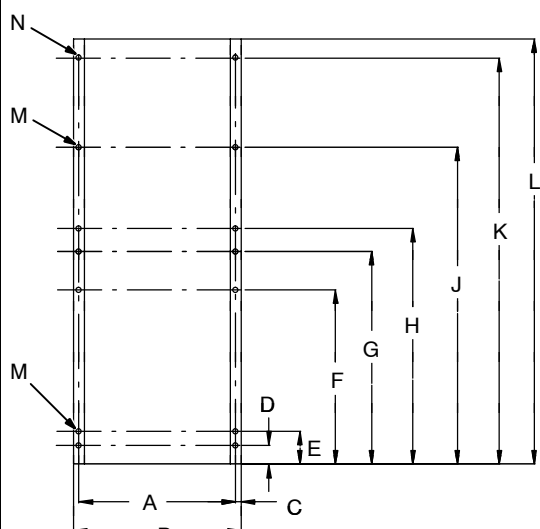

Ref. 110 850-F



▲ Do not exceed tilt angles or engine could be damaged or unit could tip.

▲ Do not move or operate unit where it could tip.

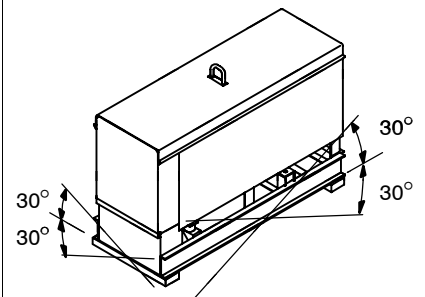

angles 4/96

4-3. Fuel Consumption

The curve shows typical fuel use under weld or power loads.

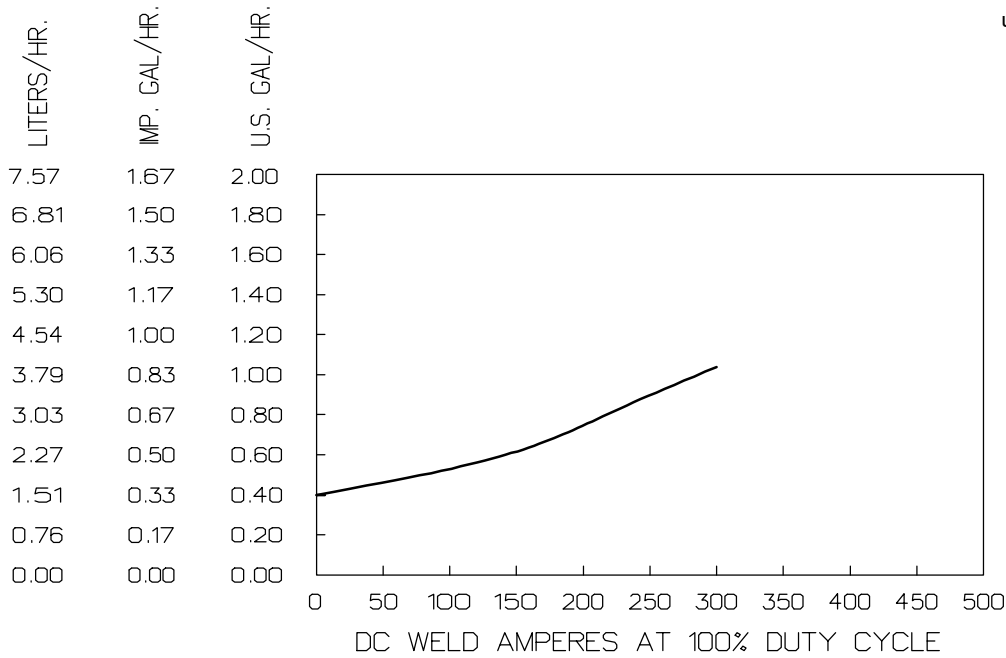

SB-137 487-A

4-4. Duty Cycle And Overheating



100% Duty Cycle At 250 Amperes

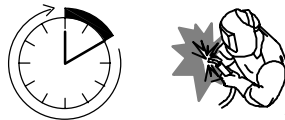

Continuous Welding

Duty Cycle is percentage of 10 minutes that unit can weld at rated load without overheating.

▲ Exceeding duty cycle can damage unit and void warranty.

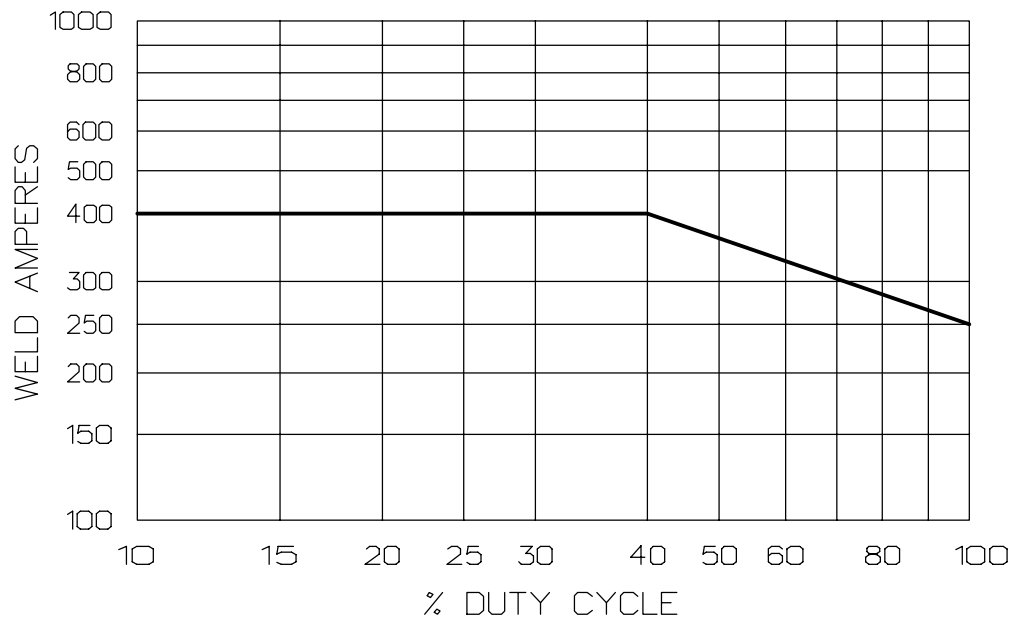

rduty1 5/95 - SB-070 999-B

4-5. AC Generator Power

The ac power curve shows the generator power in amperes available at the 120 and 240 volt receptacles.

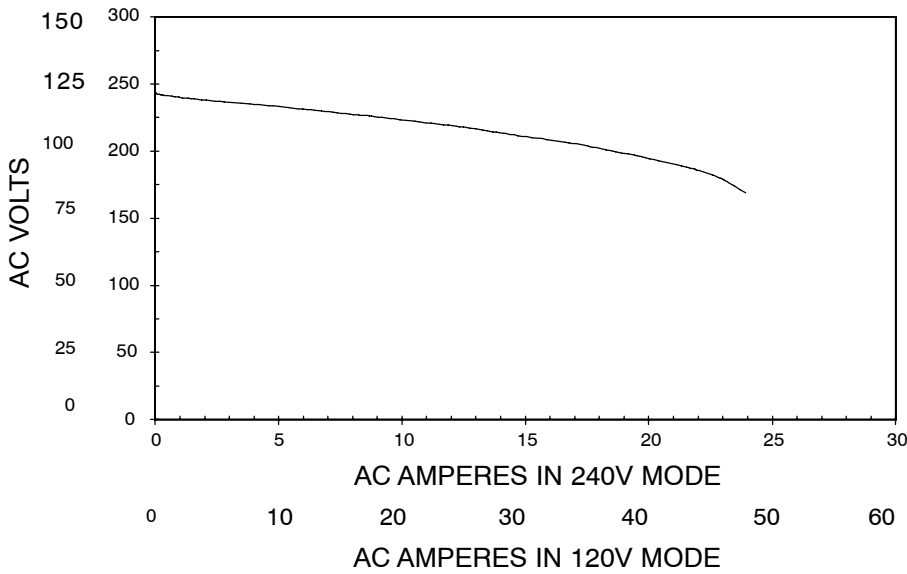

rsb3.1 2/92 - 206 031

4-6. Volt-Ampere Curves

The volt-ampere curve shows the minimum and maximum voltage and amperage output capabilities of the welding generator. Curves of all other settings fall between the curves shown.

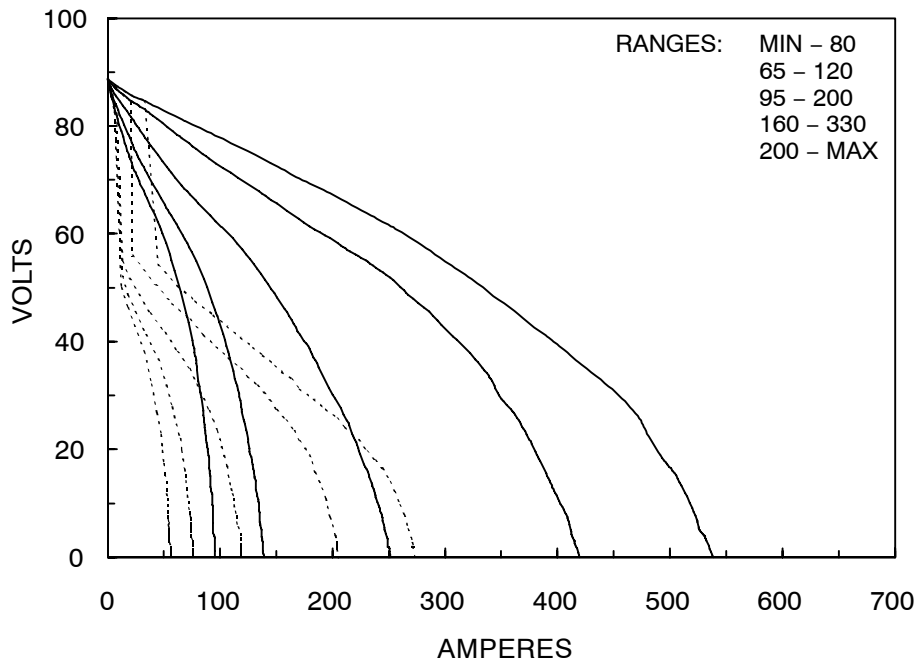

206 033

4-7. Optional AC Power Plant Curves

The ac power curves show the generator power in amperes available at the single-phase 120/240 volt or three-phase 240 volt terminals.

A. 7.5 KVA/KW Single-Phase AC Power Plant (No Weld Load)

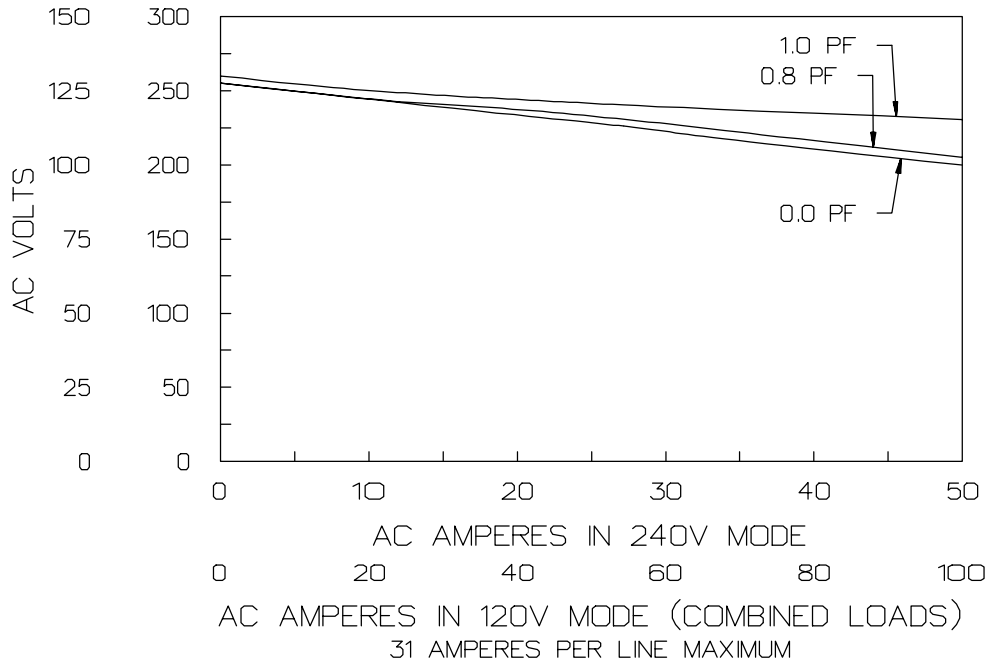

B. 10 KVA/KW Three-Phase AC Power Plant (No Weld Load)

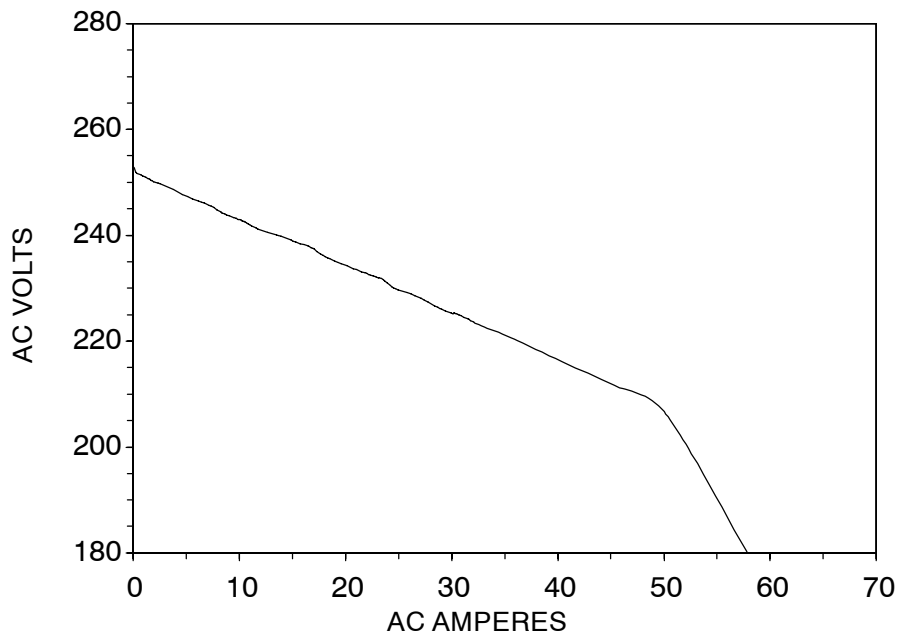

rsb13.1 12/94 - 134 636-A / 206 032

SECTION 5 – INSTALLATION

5-1. Installing Welding Generator

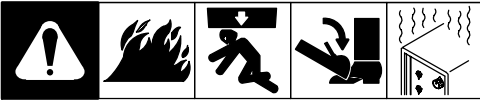

Movement

▲ Do Not Lift Unit From End

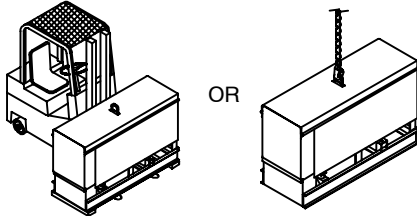

Airflow Clearance

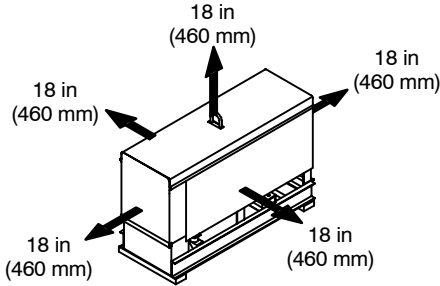

Location

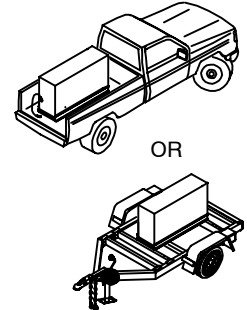

Grounding

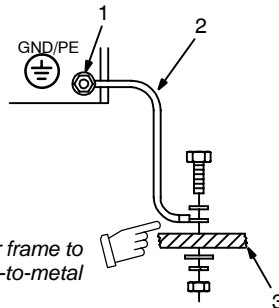

Electrically bond generator frame to vehicle frame by metal-to-metal contact.

▲ Bed liners, shipping skids, and some running gears insulate the welding generator from the vehicle frame. Always connect a ground wire from the generator equipment grounding terminal to bare metal on the vehicle frame as shown.

▲ Always securely fasten welding generator onto transport vehicle or trailer and comply with all DOT and other applicable codes.

▲ Always ground generator frame to vehicle frame to prevent electric shock and static electricity hazards.

▲ If unit does not have GFCI receptacles, use GFCI-protected extension cord.

- 1 Equipment Grounding Terminal (On Front Panel)
- 2 Grounding Cable (Not Supplied)
- 3 Metal Vehicle Frame

Connect cable from equipment ground terminal to metal vehicle frame. Use #10 AWG or larger insulated copper wire.

install1 11/02 – Ref. ST-800 652 / Ref. ST-800 477-A / ST-158 936-A / S-0854

5-2. Connecting The Battery

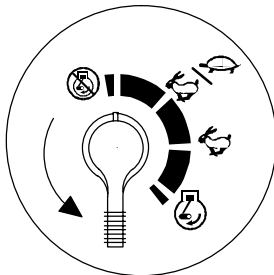

▲ Connect Negative (-) Cable Last.

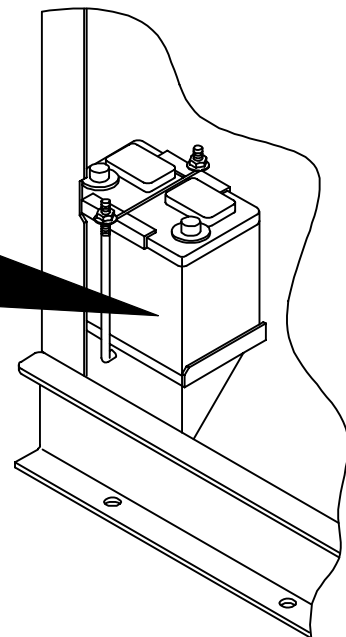
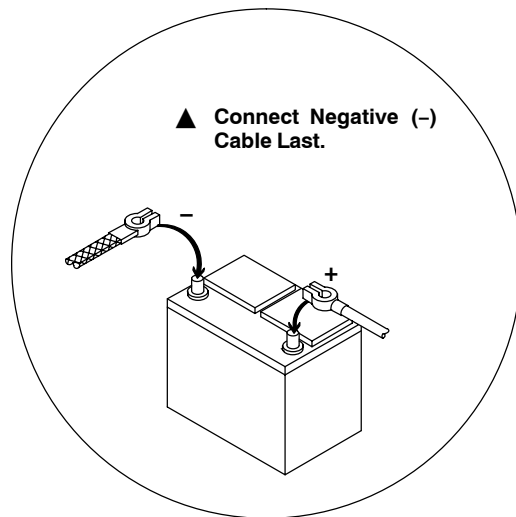

Tools Needed:

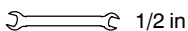

156 011-A / Ref. 206 029 / S-0756

5-3. Installing Muffler Pipe

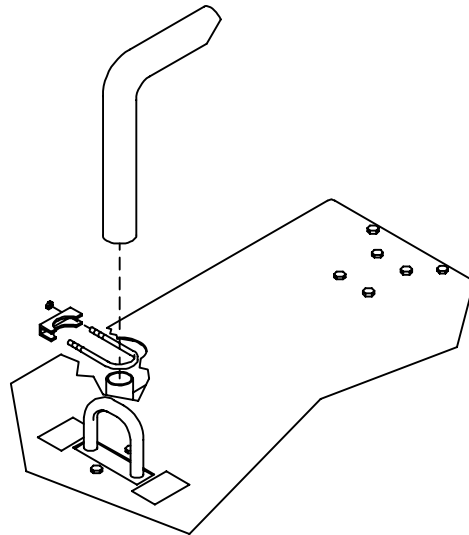
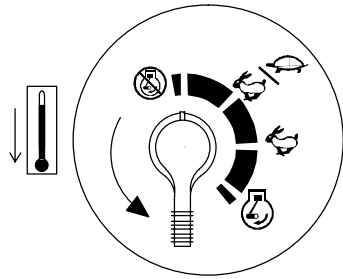

- ▲ Stop engine and let cool.
- ▲ Do not blow exhaust toward air cleaner or air intake.

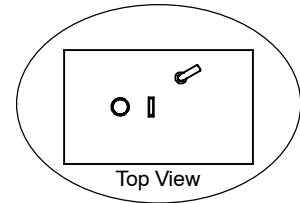

Tools Needed:

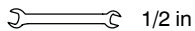

exh_pipe2 12/96 - 154 089-A / 154 611 / Ref. 206 029

5-4. Engine Prestart Checks

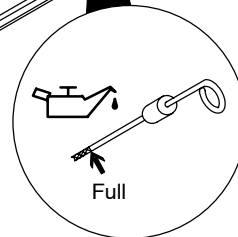
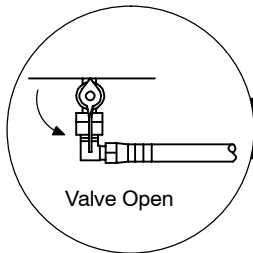
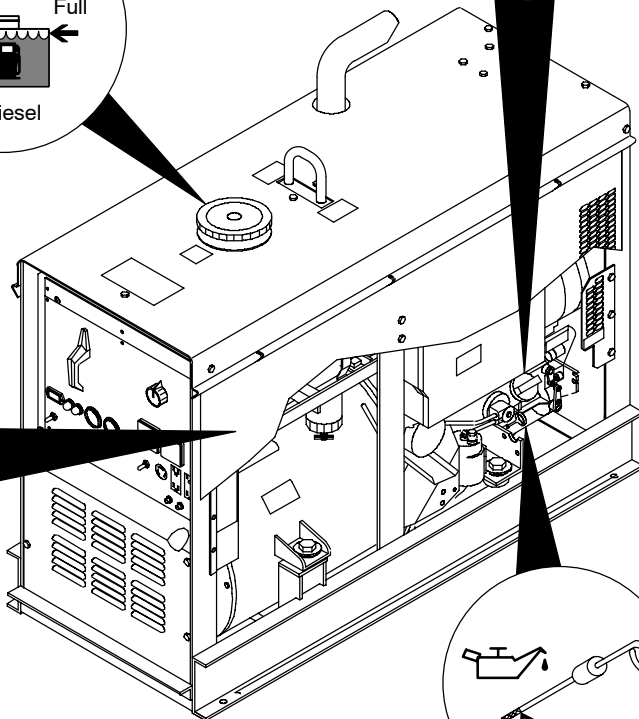
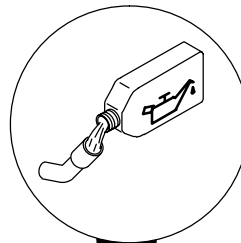
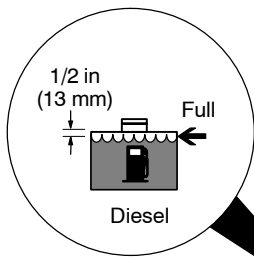
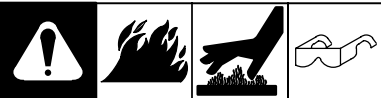

Check all fluids daily. Engine must be cold and on a level surface.

Follow run-in procedure in engine manual. If unburned fuel and oil collect in exhaust pipe during run-in, see Section 10.

Fuel

- ▲ Do not use gasoline. Gasoline will damage engine.

Add fresh diesel fuel before starting engine the first time (see maintenance label for specifications). Fill fuel tank up to 1/2 in. (13 mm) from top to allow room for expansion. Open fuel shut-off valve.

Do not run out of fuel or air enters fuel system and causes starting problems. See engine manual to bleed air from fuel system.

Oil

After fueling, check oil with unit on level surface. If oil is not up to full mark on dipstick, add oil (see maintenance label).

☞ Your unit may have the optional low oil pressure shutdown switch. However, some conditions may cause engine damage before the engine shuts down. Check oil level often and do not use the oil pressure shutdown system to monitor oil level.

☞ To improve cold weather starting:

Keep battery in good condition. Store battery in warm area.

Use fuel formulated for cold weather (diesel fuel can gel in cold weather). Contact local fuel supplier for fuel information.

Use correct grade oil for cold weather.

Ref. 800 159-D

5-5. Installing Ether Cylinder (Optional Ether Starting Aid)

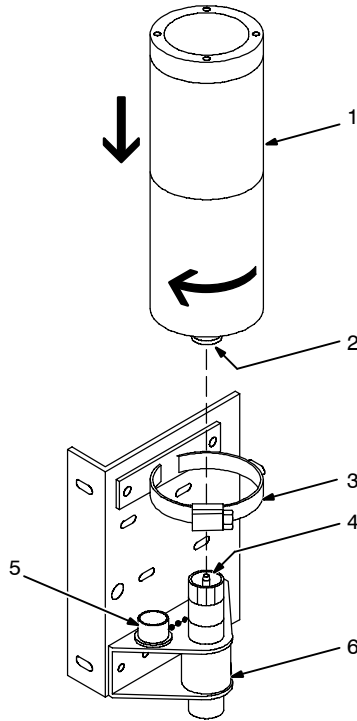
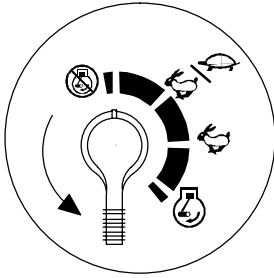

- ▲ Stop engine.
- ▲ Improper handling or exposure to ether can harm your health. Follow manufacturer's safety instructions on cylinder.
- ▲ Do not use Ether Starting Aid while engine is running.

Open side door(s).

- 1 Ether Cylinder
- 2 Nozzle

Remove cover and clean cylinder nozzle.

- 3 Clamp
- 4 Fitting
- 5 Cap
- 6 Valve

Remove cap and clean fitting. Install cylinder on fitting. Tighten clamp.

 After installing cylinder, wait at least 10 minutes before using to let ether particles settle and prevent atomizer plugging.

Put cap on fitting when cylinder is removed.

ether1 12/96 - 153 382-A / Ref. 206 029

5-6. Connecting To Weld Output Terminals

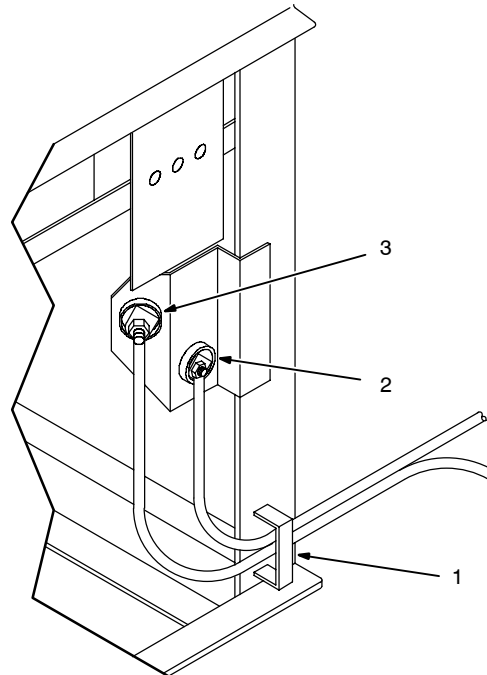
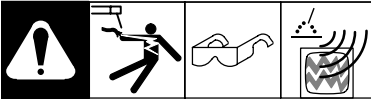

Open left side door.

- 1 Bracket

Route cables through bracket.

- 2 Positive (+) Weld Output Terminal
- 3 Negative (-) Weld Output Terminal

For Stick welding Direct Current Electrode Positive (DCEP), connect work cable to (-) terminal and electrode holder cable to (+) terminal.

For Direct Current Electrode Negative (DCEN), reverse cable connections.

If equipped with optional polarity switch, connect electrode holder cable to Electrode (-) terminal and work cable to Work (+) terminal.

For FCAW welding, connect work cable to (-) terminal and wire feeder cable to (+) terminal.

Close door.

Tools Needed:

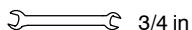

Ref. 800 162-A

5-7. Selecting Weld Cable Sizes*

 <p>Weld Output Terminals</p> <p>▲ Turn off power before connecting to weld output terminals.</p> <p>▲ Do not use worn, damaged, undersized, or poorly spliced cables.</p>	Welding Amperes	Weld Cable Size** and Total Cable (Copper) Length in Weld Circuit Not Exceeding***							
		100 ft (30 m) or Less		150 ft (45 m)	200 ft (60 m)	250 ft (70 m)	300 ft (90 m)	350 ft (105 m)	400 ft (120 m)
		10 – 60% Duty Cycle	60 – 100% Duty Cycle	10 – 100% Duty Cycle					
	100	4 (20)	4 (20)	4 (20)	3 (30)	2 (35)	1 (50)	1/0 (60)	1/0 (60)
	150	3 (30)	3 (30)	2 (35)	1 (50)	1/0 (60)	2/0 (70)	3/0 (95)	3/0 (95)
	200	3 (30)	2 (35)	1 (50)	1/0 (60)	2/0 (70)	3/0 (95)	4/0 (120)	4/0 (120)
	250	2 (35)	1 (50)	1/0 (60)	2/0 (70)	3/0 (95)	4/0 (120)	2 ea. 2/0 (2x70)	2 ea. 2/0 (2x70)
	300	1 (50)	1/0 (60)	2/0 (70)	3/0 (95)	4/0 (120)	2 ea. 2/0 (2x70)	2 ea. 3/0 (2x95)	2 ea. 3/0 (2x95)
	350	1/0 (60)	2/0 (70)	3/0 (95)	4/0 (120)	2 ea. 2/0 (2x70)	2 ea. 3/0 (2x95)	2 ea. 3/0 (2x95)	2 ea. 4/0 (2x120)
	400	1/0 (60)	2/0 (70)	3/0 (95)	4/0 (120)	2 ea. 2/0 (2x70)	2 ea. 3/0 (2x95)	2 ea. 4/0 (2x120)	2 ea. 4/0 (2x120)
	500	2/0 (70)	3/0 (95)	4/0 (120)	2 ea. 2/0 (2x70)	2 ea. 3/0 (2x95)	2 ea. 4/0 (2x120)	3 ea. 3/0 (3x95)	3 ea. 3/0 (3x95)

* This chart is a general guideline and may not suit all applications. If cable overheating occurs (normally you can smell it), use next size larger cable.

**Weld cable size (AWG) is based on either a 4 volts or less drop or a current density of at least 300 circular mils per ampere.
() = mm² for metric use

***For distances longer than those shown in this guide, call a factory applications representative at 920-735-4505.

S-0007-E-

SECTION 6 – OPERATING THE WELDING GENERATOR

6-1. Controls (See Section 6-2)

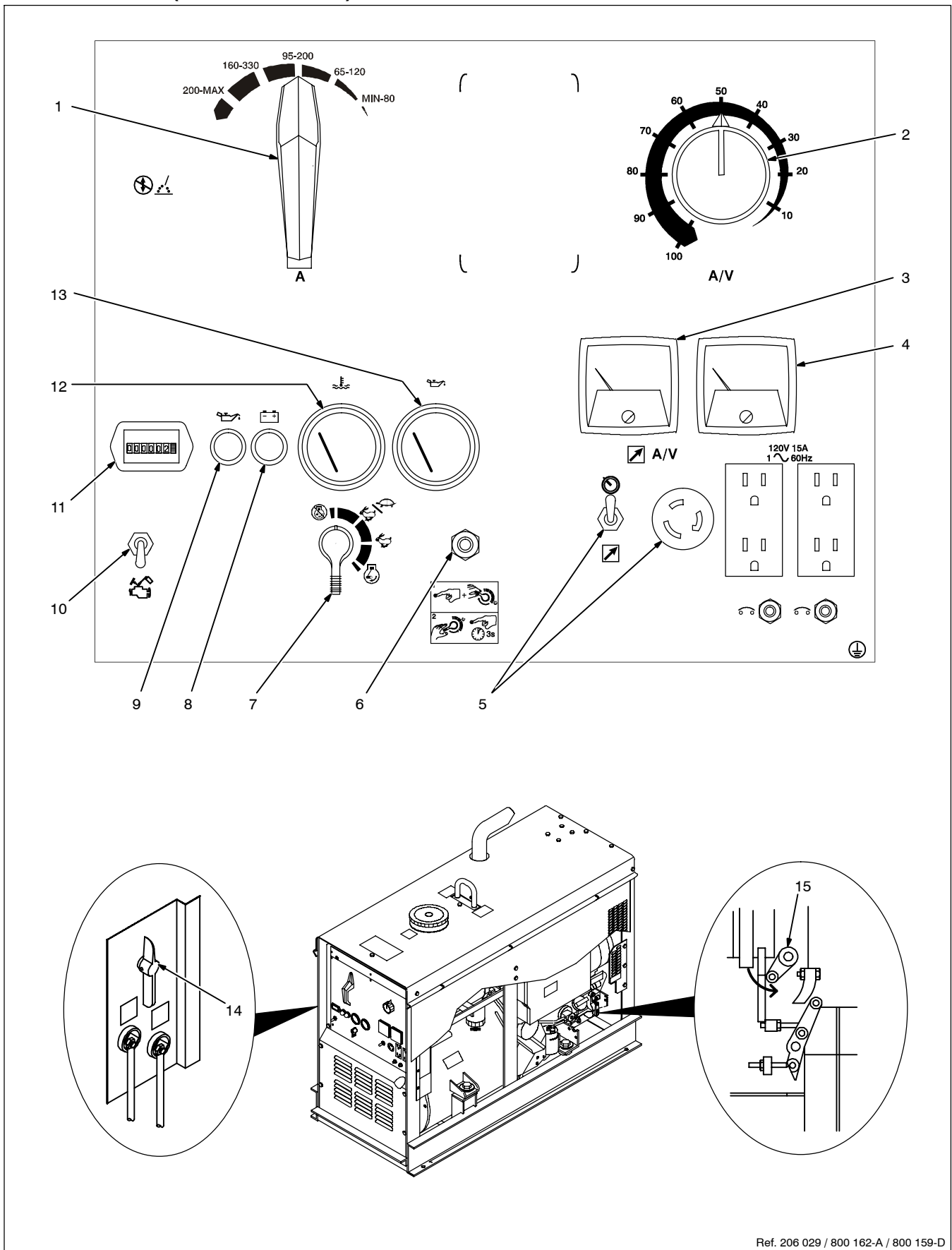

Ref. 206 029 / 800 162-A / 800 159-D

6-2. Description Of Front Panel Controls (See Section 6-1)

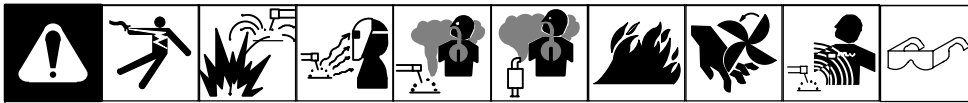

☞ This unit has a max OCV control circuit that resets the Amperage/Voltage Control to maximum when the arc breaks. When an arc is struck, weld output control returns to the front panel or remote control setting. The Amperage/voltage Control adjusts amperage only when welding and does not adjust open-circuit voltage.

1 Ampere Range Switch

Use switch to select weld amperage range. For most welding applications, use lowest amperage range possible to prevent arc outages.

▲ Do not switch under load.

2 Amperage/Voltage Control

Control adjusts amperage within range selected by Ampere Range switch. Weld output would be 148 A DC with controls set as shown (50% of 95 to 200 A).

3 DC Voltmeter (Optional)

4 DC Ammeter (Optional)

5 Remote A/V Switch And Receptacle

(See Section 6-3)

6 Magnetic Shutdown Switch (Optional)

Use switch during start-up to bypass optional engine shutdown system. System stops engine if oil pressure is too low or oil temperature is too high.

7 Engine Control Switch

To Start: turn switch to Start while pressing Shutdown switch. Release switches when engine starts.

☞ If the engine does not start, let engine come to a complete stop before attempting restart.

In Run position, engine runs at weld/power speed. In Run/Idle position (optional), engine runs at idle speed at no load and weld/power speed with load applied.

To Stop: turn switch to Off position.

8 Battery Charging Warning Light

Light goes on when battery is not charging.

9 Oil Pressure Warning Light

Light goes on if oil pressure is too low. If unit has automatic shutdown option, light also goes on if oil temperature is too high.

▲ Stop engine and fix trouble if either light goes on.

10 Ether Starting Aid Switch (Optional)

Push switch up and release while cranking engine to release ether.

▲ Do not use Ether if engine is running.

11 Engine Hour Meter

12 Oil Temperature Gauge/Switch (Optional)

13 Oil Pressure Gauge/Switch (Optional)

14 Polarity Switch (Optional)

Place switch in Straight position for electrode negative, or Reverse position for electrode positive.

15 Manual Shutoff Lever

Use lever to stop engine if engine control switch does not work.

6-3. Remote A/V Control



↗ A/V

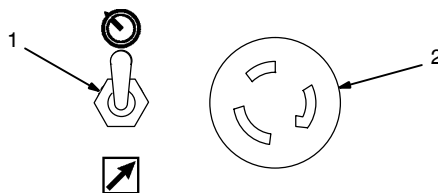

1 A/V Control Switch

Use switch to select front panel or remote amperage control.

2 Remote A/V Receptacle RC3

Connect optional remote control to RC3.

Example: Combination Remote Amperage Control

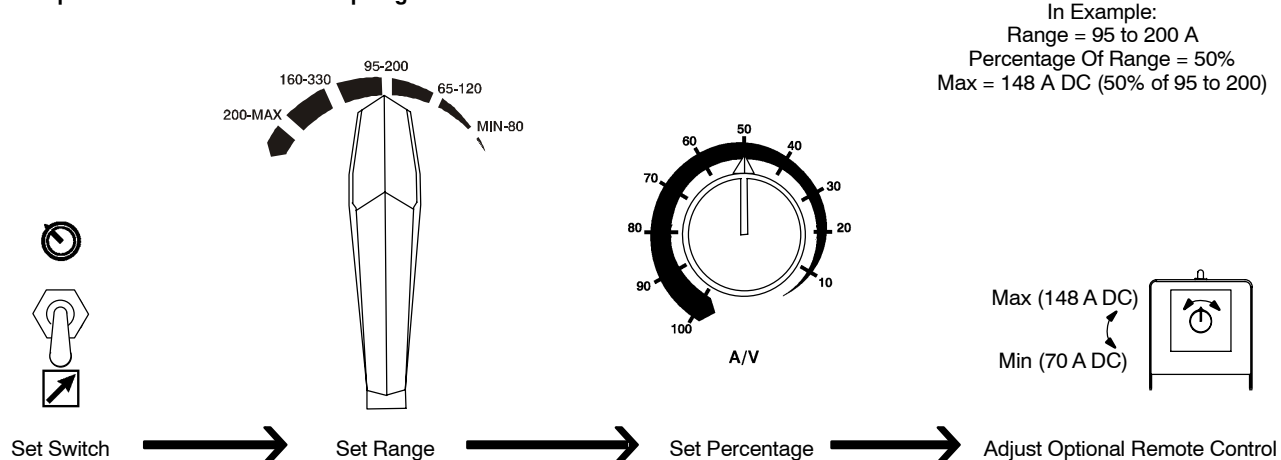

S-0774

SECTION 7 – OPERATING AUXILIARY EQUIPMENT

7-1. 120 Volt Duplex And Optional GFCI Receptacles

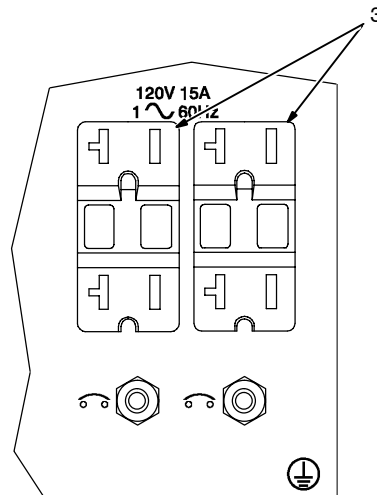
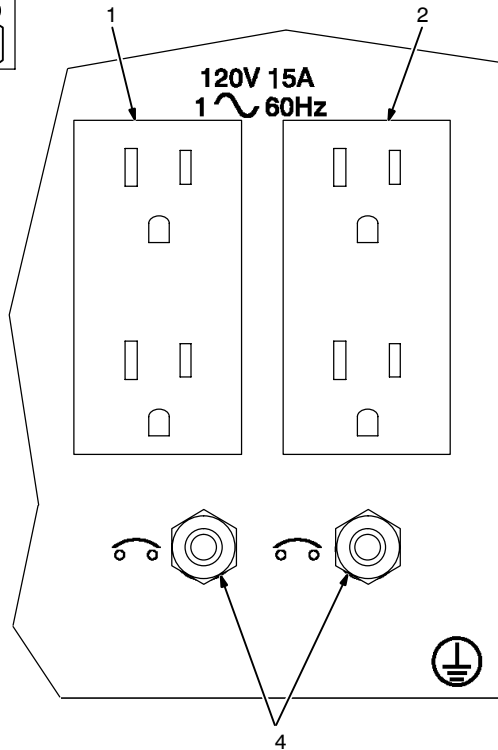

▲ If unit does not have GFCI receptacles, use GFCI-protected extension cord.

- 1 120 V 15 A AC Receptacle RC1
- 2 120 V 15 A AC Receptacle RC2
- 3 120 V 20 A AC GFCI Receptacles GFCI1 And GFCI2 (Optional)

Receptacles supply 60 Hz single-phase power at weld/power speed.

- 4 Circuit Breakers CB1 And CB2

CB1 protects RC1/GFCI1 and CB2 protects RC2/GFCI2 from overload. If CB1 or CB2 opens, the receptacle does not work.

☞ If a circuit breaker continues to open, contact Factory Authorized Service Agent.

If a ground fault is detected, GFCI Reset button pops out and receptacle does not work. Check for faulty tools plugged in receptacle. Press button to reset.

☞ At least once a month, run engine at weld/power speed and press test button to verify GFCI is working properly.

Maximum output from each duplex receptacle is 1.8 kVA/kW, and 3 kVA/kW from all receptacles. Generator power is not affected by weld output.

EXAMPLE: If 15 A is drawn from RC1, only 10 A is available at RC2:

$$(120 \text{ V} \times 15 \text{ A}) + (120 \text{ V} \times 10 \text{ A}) = 3.0 \text{ kVA/kW}$$

Ref. 206 029

7-2. 240 Volt Duplex Receptacle (Optional)

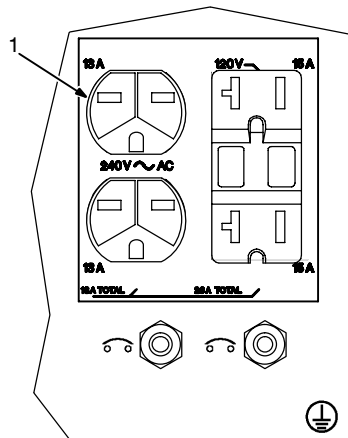
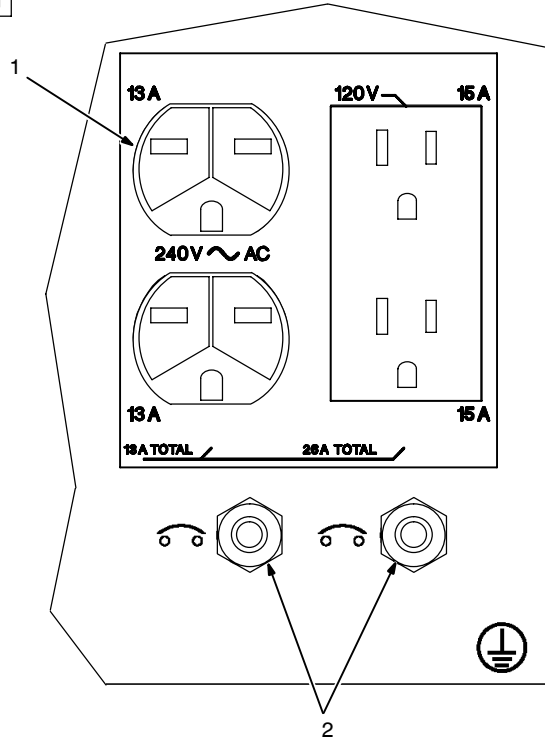

▲ If unit does not have GFCI receptacles, use GFCI-protected extension cord.

- 1 240 V 15 A AC Receptacle RC1

Receptacle supplies 60 Hz single-phase power at weld/power speed. Maximum output is 3 kVA/kW.

- 2 Circuit Breakers CB1 And CB2

CB1 and CB2 protect the receptacles from overload. If CB1 or CB2 opens, the 240 V receptacle and half of the 120 V receptacle does not work. 120 volts may still be present at the 240 V receptacle.

☞ If a circuit breaker continues to open, contact Factory Authorized Service Agent.

Combined output of all receptacles is 3 kVA/kW. Generator power is not affected by weld output.

EXAMPLE: If 10 A is drawn from the 240 V receptacle, only 5 A is available at the 120 V receptacle:

$$(240 \text{ V} \times 10 \text{ A}) + (120 \text{ V} \times 5 \text{ A}) = 3.0 \text{ kVA/kW}$$

Ref. 206 029 / 174 408

7-3. Connecting Optional AC Power Plant



- ▲ Stop engine.
- ▲ Power and weld outputs are live at the same time. Disconnect or insulate unused cables.

☞ Have qualified person install according to circuit diagram and Generator Power Guidelines (Section 11).

Remove junction box cover.

- 1 Lead 93
- 2 Lead 92
- 3 Lead 91
- 4 Lead 90 (Neutral)
- 5 Lead 42 (Circuit Grounding Lead)

Lead 42 connects to front panel Ground stud.

- 6 Grounding Terminal
- 7 Jumper Lead 42
- 8 Isolated Neutral Terminal

Jumper 42 is connected to lead 90 at factory. Jumper 42 may be disconnected from neutral to meet applicable electrical codes.

- 9 Lead 80
- 10 Receptacle RC9 leads
- 11 Lead 42
- 12 Lead 81
- 13 Lead 82

14 Load Terminals

Connect leads to terminals.

15 Fuses F1, F2, And F3

F1, F2, and F3 protect each load line from overload.

☞ Set Engine Control switch to Run when using generator power.

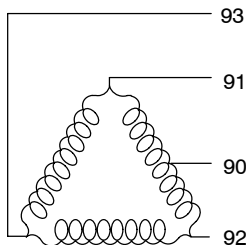
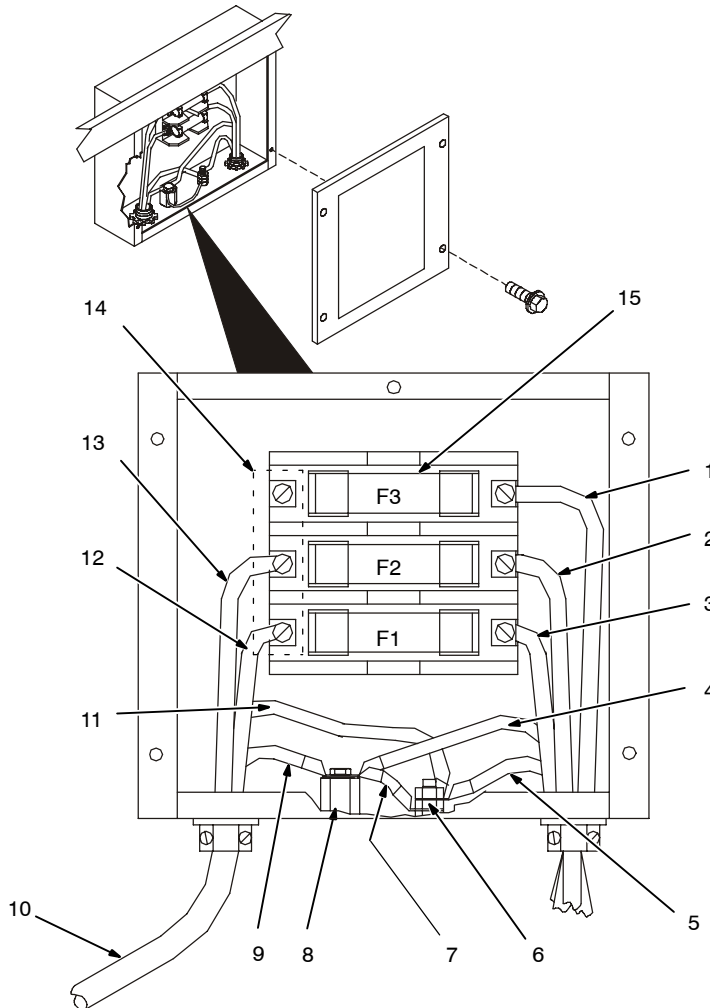

AC Output	Single Phase 1 ~	Three Phase 3 ~
Volts	120/240	240
Amps	31	24
KVA/KW	7.5	10
Frequency	60 Hz	
Engine Speed	1850 RPM	
Max. Fuse Size	35 Amperes	

Lead 42 connects to GROUND stud on front of unit.
Jumper 42 is connected to 90 at factory.

Tools Needed:

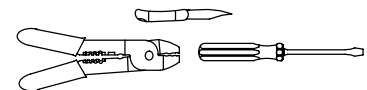

Ref. S-179 637-B

7-4. 120/240 Volt Twistlock Receptacle (Optional)

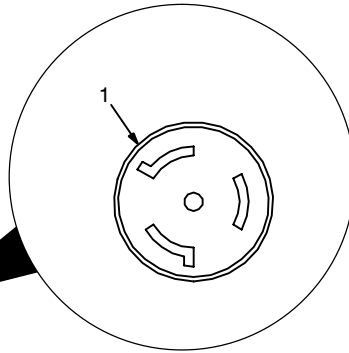
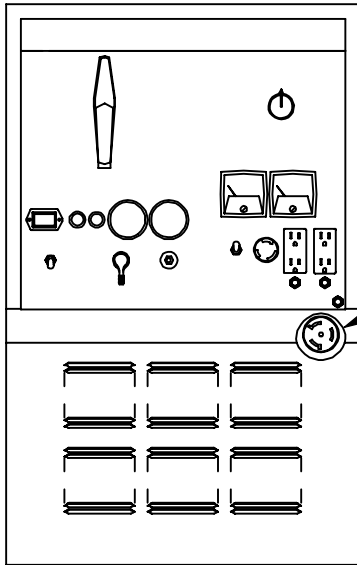

1 120/240 V 50 A Twistlock Receptacle RC9

RC9 is connected to the optional ac power plant and supplies 60 Hz single-phase power at weld/power speed. Maximum output from receptacle is 7.5 kVA/kW.

Power available at RC9 is reduced when welding.

Fuses F1 and F2 protect RC9 from overload (see Section 7-3). If a fuse opens, the receptacle does not work. 120 volts may still be present at RC9.

801 057-A

SECTION 8 – MAINTENANCE AND TROUBLESHOOTING

8-1. Routine Maintenance

			<p>▲ Stop engine before maintaining.</p> <p>☞ See <i>Engine Manual and Maintenance Label</i> for important start-up, service, and storage information. Service engine more often if used in severe conditions.</p> <p>* To be done by Factory Authorized Service Agent.</p>		
Recycle engine fluids.					
Every 8 h					
Wipe Up Spills.		Check Fluid Levels. See Section 5-4.		FUEL WATER Drain Water From Fuel System. See Section 8-4.	
Every 50 h					
Clean Air Filter. See Section 8-3.			Clean And Tighten Weld Terminals.		
Every 100 h					
Check air cleaner hoses for cracks and loose clamps.		Clean Cooling System.		Clean And Tighten Battery Connections.	
Every 200 h			Every 250 h		
Replace Unreadable Labels.			Check And Clean Spark Arrester. See Section 8-8.		
Every 500 h					
Change Oil. See Section 8-4.		Change Oil Filter. See Section 8-4.		Repair Or Replace Cracked Cables.	
Every 1000 h					
Blow Out Or Vacuum Inside. During Heavy Service, Clean Monthly.		Change Fuel Filters. See Section 8-4.		Service Welding Generator Brushes And Slip Rings. Service More Often In Dirty Conditions.*	
1/2 in. (13 mm) Check Belt Tension.		FUEL SLUDGE Drain Sludge From Fuel Tank. See Section 8-4.		Check Valve Clearance.*	
Every 3000 h					
Clean/Set Injectors.*					

NOTE

Follow the storage procedure in the engine owner's manual if the unit will not be used for an extended period.

8-2. Maintenance Label

DEUTZ F3L1011F DIESEL ENGINE

 See Engine Manual for complete engine care.
Give Engine Specification and Serial Number when ordering parts.



Check daily.





* Only with engine oil preheating.



Recommended Oil	API Service Classification
	CC/SE, CC/SF CD/SE, CD/SF
	(or better) (or better)
Oil Change & Filter	
dirty conditions	250 hours 375 hours
normal conditions	500 hours 750 hours
Oil Filter	MILLER 067 265, Deutz 116-4626, Fram PH46
Oil Capacity	5.8 qt (5.5 L) or 6.2 qt (5.9 L) with filter change

Fuel Capacity	11.3 gal (42.8 L)
Fuel Grade	1-D or 2-D Cetane No. 45 min.
Primary Fuel Filter/ Water Separator	MILLER 192744, Donaldson P550587, Fram P1145A
Secondary Fuel Filter	MILLER 066 217, Deutz 117-4696
<i>Fill filter with clean fuel before installing - read instructions on filter.</i>	

	Air Filter Service	50 hours or less - see Owner's Manual
	Air Filter Element	MILLER 197676, Donaldson P821575, WIX 46438
	Air Filter Element (Safety) Opt	MILLER 197679, Donaldson P822858

	Blower Belt ... Gates 7435, Deutz 117-9565
	<i>Avoid recirculation of air from hot air exit to blower intake.</i>

	Battery	BCI Group 55
	Cranking Performance at 0°F (-18°C)	500 Amps

	Engine RPM - No Load Weld	1850
		Valve Clearance - Cold Intake
		0.012 in (0.3 mm) Exhaust ... 0.020 in (0.5 mm)

 *Have only trained technician maintain injection pump and injectors. AIR, WATER, or GASOLINE will harm the injection system.*

Injectors should be checked annually.

	Spark Arrestor Inspection and Service	250 operating hours - See Owner's Manual
---	---	---

173 847-E

8-3. Servicing Air Cleaner

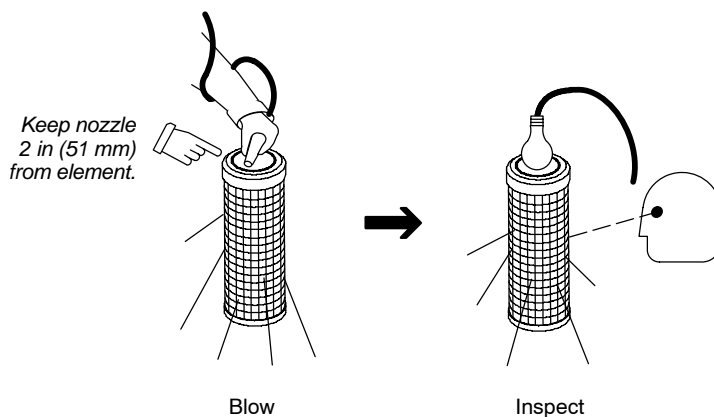
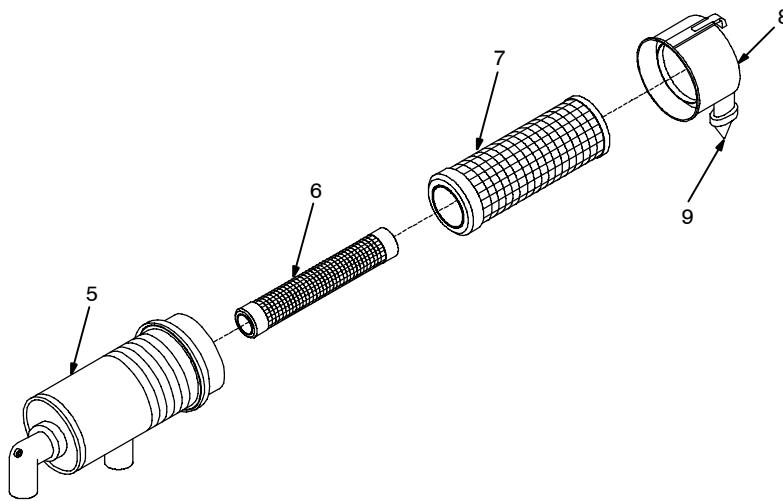
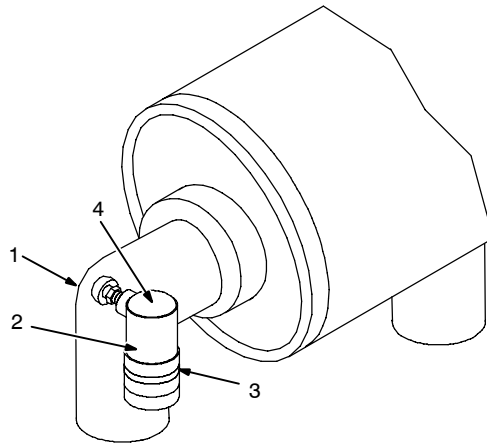
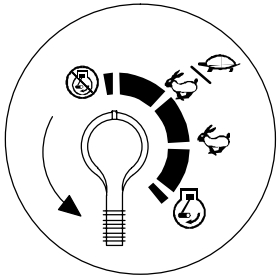

▲ Stop engine.

▲ Do not run engine without air cleaner or with dirty element. Engine damage caused by using a damaged element is not covered by the warranty.

☞ The air cleaner primary element can be cleaned but the dirt holding capacity of the filter is reduced with each cleaning. The chance of dirt reaching the clean side of the filter while cleaning and the possibility of filter damage makes cleaning a risk. Consider the risk of unwarrantable equipment damage when determining whether to clean or replace the primary element.

If you decide to clean the primary element, we strongly recommend installing an optional safety element to provide additional engine protection. **Never clean a safety element.** Replace the safety element after servicing the primary element three times.

- 1 Air Cleaner
- 2 Service Indicator (Optional)
- 3 Window
- 4 Reset Button

Service air cleaner element if red band appears in window. A green band means air cleaner is okay. Press button to reset indicator.

Clean or replace primary element if dirty (see note above before cleaning). **Replace** primary element if damaged. Replace primary element yearly or after six cleanings.

- 5 Housing
- 6 Safety Element (Optional)
- 7 Primary Element
- 8 Cover
- 9 Dust Ejector

To clean air filter:

Wipe off cover and housing. Remove cover and dump out dust. Remove element(s). Wipe dust from inside cover and housing with damp cloth. Reinstall safety element (if present). Reinstall cover.

▲ Do not clean housing with air hose.

Clean primary element with compressed air only.

Air pressure must not exceed 100 psi (690 kPa). Use 1/8 in (3 mm) nozzle and keep nozzle at least 2 in (51 mm) from inside of element. Replace primary element if it has holes or damaged gaskets.

Reinstall primary element and cover (dust ejector down).

8-4. Servicing Fuel And Lubrication Systems

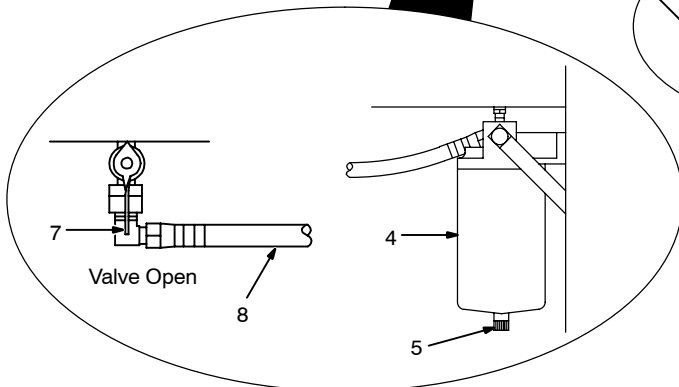
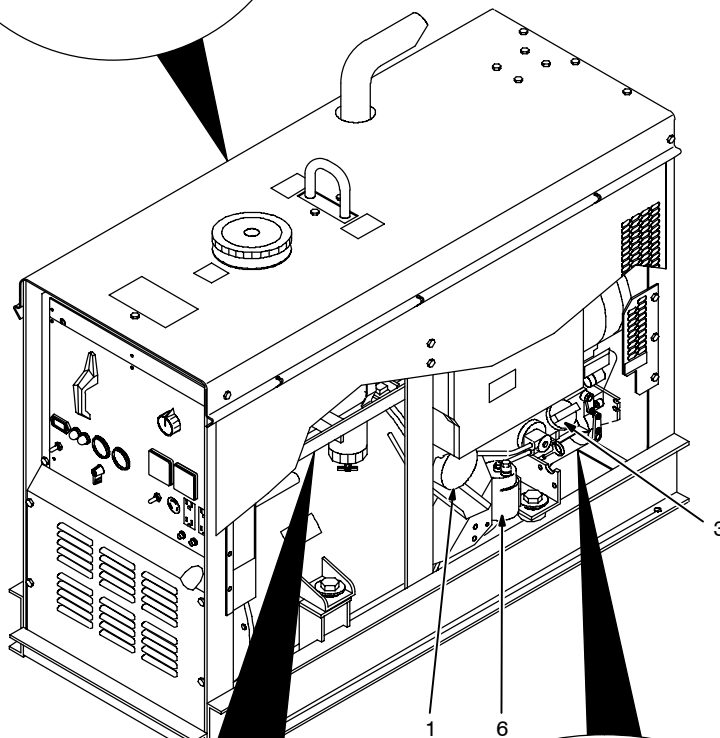
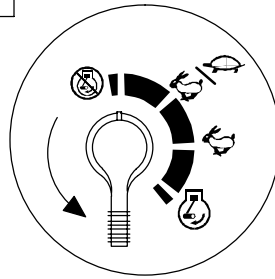
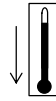
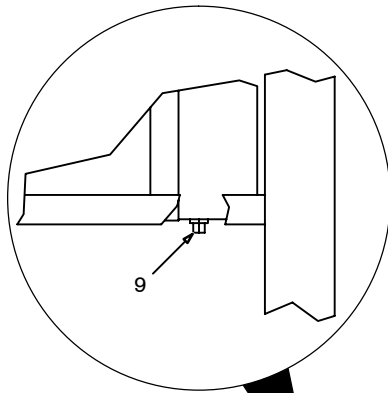

▲ Stop engine and let cool.

- 1 Oil Filter
- 2 Oil Drain Plug
- 3 Oil Fill Cap
- 4 Primary Fuel Filter (Fuel/Water Separator)
- 5 Petcock
- 6 Secondary Fuel Filter
- 7 Fuel Shutoff Valve
- 8 Fuel Line
- 9 Sludge Drain Plug

To change oil and filter:

See engine manual.

To drain water from fuel system:

Open primary fuel filter petcock and drain water into metal container. Close petcock when water-free fuel flows.

To replace primary fuel filter:

Close shutoff valve and turn filter counterclockwise. Remove filter.

Apply thin coat of fuel to gasket on new filter. Install new filter and turn clockwise. Open shutoff valve. Bleed air from fuel system according to engine manual.

Inspect fuel line, and replace if cracked or worn.

To replace secondary fuel filter:

See engine manual.

To drain sludge from fuel tank:

Put metal container under drain, and remove sludge drain plug. Re-install plug when done.

▲ After servicing, start engine and check for fuel leaks.

▲ Stop engine, tighten connections as necessary, and wipe up spilled fuel.

Close doors.

Tools Needed:

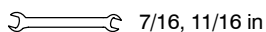

Ref. 800 159-E / Ref. 206 029

8-5. Adjusting Engine Speed

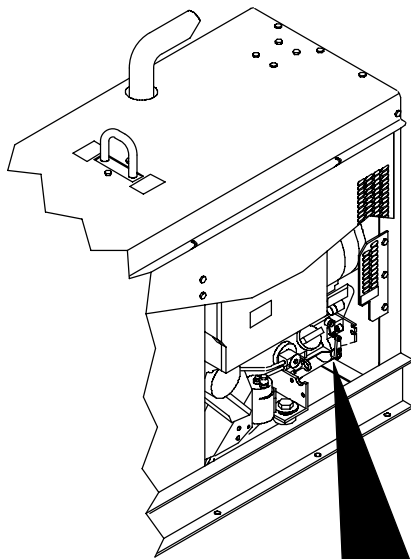

	1850 rpm (61.6 Hz)
	1250 rpm (41.5 Hz)

After tuning engine, check engine no load speed with a tachometer (see table for no load speeds). If necessary, adjust speed as follows:

Start engine and run until warm. Turn Amperage/Voltage Control to 100.

Standard Models:

- 1 Engine Speed Adjustment Screw
- 2 Locking Nut

Loosen nut. Turn screw until engine runs at 1850 rpm. Tighten nut.

Models With Automatic Idle (Optional)

- 3 Throttle Rod
- 4 Locknut

Loosen locknuts. Place engine control switch in Run/Idle position.

Turn throttle rod until engine runs at idle speed. Tighten locknuts.

- 5 Engine Speed Adjustment Screw
- 6 Locknut

Place engine control switch in Run position.

Loosen locknut. Turn screw until engine runs at weld/power speed. Tighten locknut.

▲ **Stop engine.**

Standard Models

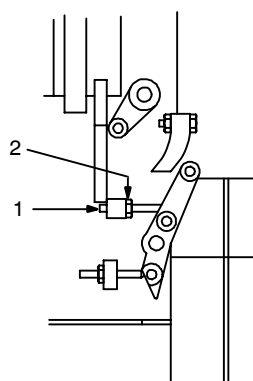

Models With Automatic Idle (Optional)

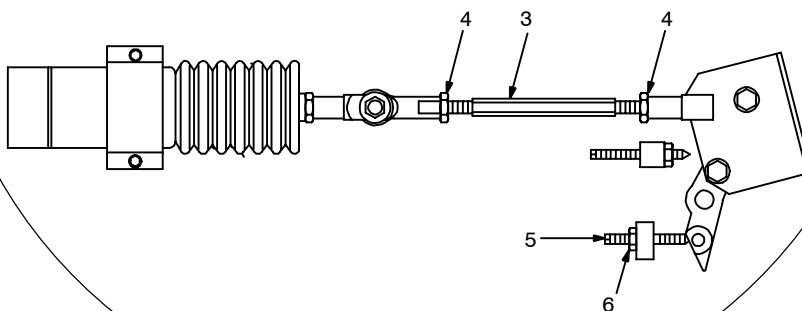

Tools Needed:

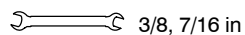

Ref. 801 179 / Ref. 800 159-D / Ref. 800 161

8-6. Overload Protection

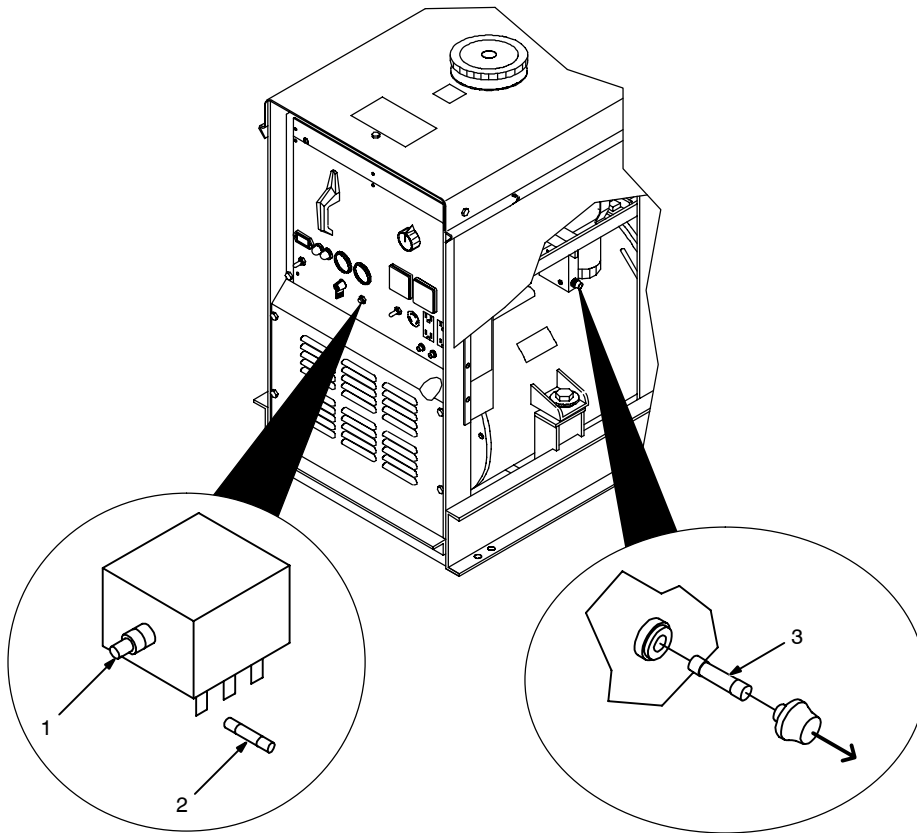

▲ Stop engine.

☞ *When a fuse opens, it usually indicates a more serious problem exists. Contact a Factory Authorized Service Agent.*

- 1 Magnetic Shutdown Switch MS1 (Optional)
- 2 Fuse F (See Parts List)
- 3 Throttle Solenoid Fuse F4 (Optional)

Fuse F protects magnetic shut-down switch MS1. If fuse F opens, the engine stops.

Fuse F4 protects the throttle solenoid from overload on models with automatic idle option. If fuse F4 opens, the engine does not run at idle speed.

Check fuses and replace if open.

Tools Needed:

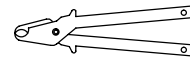

Ref. 156 199-B / 801 320-B

8-7. Servicing Optional Ether Starting Aid

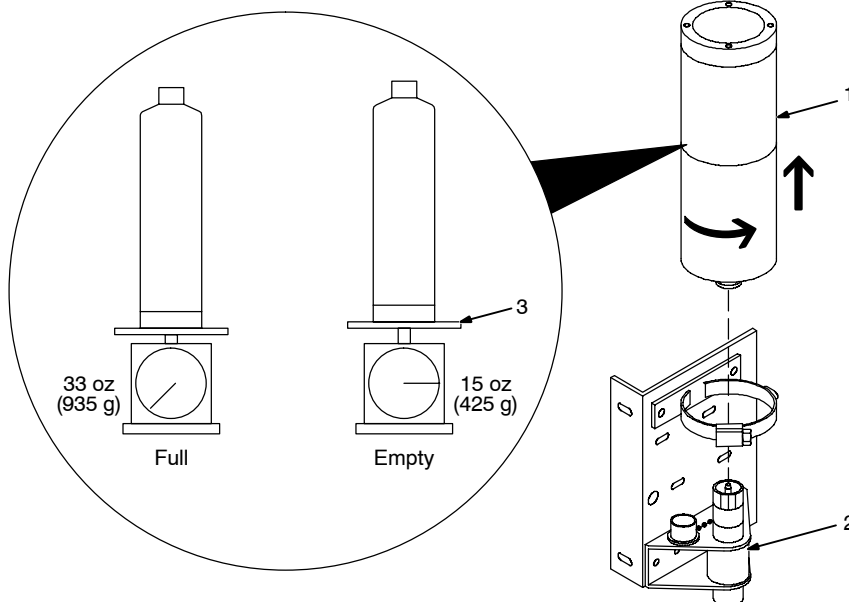

▲ Stop engine.

▲ **Improper handling or exposure to ether can harm your health. Follow manufacturer's safety instructions on cylinder.**

If engine does not start in cold weather, check ether cylinder as follows:

Remove cylinder from valve.

- 1 Ether Cylinder
- 2 Valve
- 3 Scale

Weigh cylinder to see if it is empty.

Be sure atomizer is not plugged and valve fitting is clean.

Replace cylinder according to Section 5-5.

ether2 7/96 - 153 382-A / S-0692

8-8. Inspecting And Cleaning Optional Spark Arrestor

▲ Stop engine and let cool.

- 1 Spark Arrestor
- 2 Cleanout Plug
- 3 Exhaust Pipe

Remove plug and remove any dirt covering cleanout hole.

- 3 Exhaust Pipe

Start engine and run at idle speed to blow out cleanout hole. If nothing blows out of hole, briefly cover end of exhaust pipe with fireproof material.

▲ Stop engine and let cool.

Reinstall cleanout plug.

Tools Needed:
 3/8 in

800 523 / Ref. 206 029

8-9. Troubleshooting

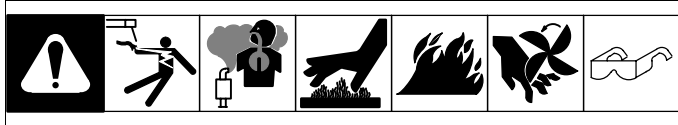

A. Welding

Trouble	Remedy
No weld output.	Check position of Ampere Range switch.
	Check position of optional Polarity switch.
	Place A/V control switch in Panel position, or place switch in Remote position and connect Remote Amperage control to Remote A/V receptacle RC3 (see Section 6-3).
	Check and secure connections to Remote A/V receptacle RC3.
	Disconnect equipment from generator power receptacles during start-up.
	Have Factory Authorized Service Agent check brushes and slip rings, and field excitation circuit.
Erratic weld output.	Use dry, properly stored electrode.
	Be sure connection to work piece is clean and tight.
	Remove excessive coils from weld cables.
	Check and tighten connections both inside and outside unit.
	Have Factory Authorized Service Agent check brushes and slip rings, and field excitation circuit.
Low or high weld output.	Check control settings.
	Check engine speed, and adjust if necessary (see Section 8-5).
Low open-circuit voltage.	Check engine speed, and adjust if necessary (see Section 8-5).
	Have Factory Authorized Service Agent check integrated rectifier SR2, Amperage/Voltage control R1, and resistor R2.
Maximum weld output only in each amperage range.	Have Factory Authorized Service Agent check Amperage/Voltage control R1, capacitor C8, diode D8, integrated rectifier SR4, and control relay CR2.

B. Generator Power

Trouble	Remedy
No output at generator power receptacles.	Reset circuit breaker CB1 and/or CB2 (see Section 7-1 or 7-2).
	Disconnect equipment from generator power receptacles during start-up.
	Have Factory Authorized Service Agent check brushes and slip rings, and field excitation circuit.
Low or high output at generator power receptacles.	Check engine speed, and adjust if necessary (see Section 8-5).
Low output at optional ac power plant junction box, or receptacle RC9.	Check engine speed, and adjust if necessary (see Section 8-5).
	If optional remote device is being used, set A/V Control switch in Remote position and remote device at maximum (see Section 6-3).
	If optional remote device not being used, set A/V Control switch in Panel position (see Section 6-3).
	Check and replace fuses F1, F2, and/or F3, if necessary (see Section 7-3).
	Have Factory Authorized Service Agent check brushes and slip rings.
No output from optional ac power plant; weld output and standard generator power receptacle output okay.	Check connections to ac power plant (see Section 7-3).
	Check fuses F1, F2, and F3 and replace if necessary (see Section 7-3).

C. Engine

Trouble	Remedy
Engine does not start.	Check fuel level. Open fuel valve (see Section 5-4).
	Check optional Magnetic Shutdown switch fuse F and replace if open (see Section 8-6).
	Check battery and replace if necessary.
	Check connections to Engine Control switch.
	Check oil level. Optional automatic shutdown system stops engine if oil pressure gets too low or oil temperature gets too high.
	See engine manual.
	Have Factory Authorized Service Agent check engine charging system.
Engine suddenly stops.	Check oil level. Optional automatic shutdown system stops engine if oil pressure gets too low or oil temperature gets too high.
	Check optional Magnetic Shutdown switch fuse F and replace if open (see Section 8-6).
Engine slowly stopped; unable to restart engine.	Check fuel level. Open fuel valve (see Section 5-4).
Engine does not stop when Engine Control switch is placed in Off position.	Use manual shutoff lever to stop engine (see Section 6-1). Check connections to Engine Control switch. Have Factory Authorized Service Agent check engine fuel solenoid.
Engine remains at idle speed when Engine Control switch is placed in Run/Idle position and an arc is struck (models with automatic idle option only.)	Have Factory Authorized Service Agent check Engine Control switch and idle module.
Engine will not run at idle speed. (models with automatic idle option only.)	Check throttle solenoid fuse F4, and replace if open (see Section 8-6).
	Have Factory Authorized Service Agent check Engine Control switch and idle module.
Battery discharges between uses.	Make sure Engine Control switch is in Off position when unit is shut down.
	Clean battery, terminals, and posts with baking soda and water solution; rinse with clear water.
	Periodically recharge battery (approximately every three months).
	Replace battery.
Engine uses oil during run-in period; wetstacking occurs.	Dry engine (see Section 10).
	See engine manual.

SECTION 9 - ELECTRICAL DIAGRAM

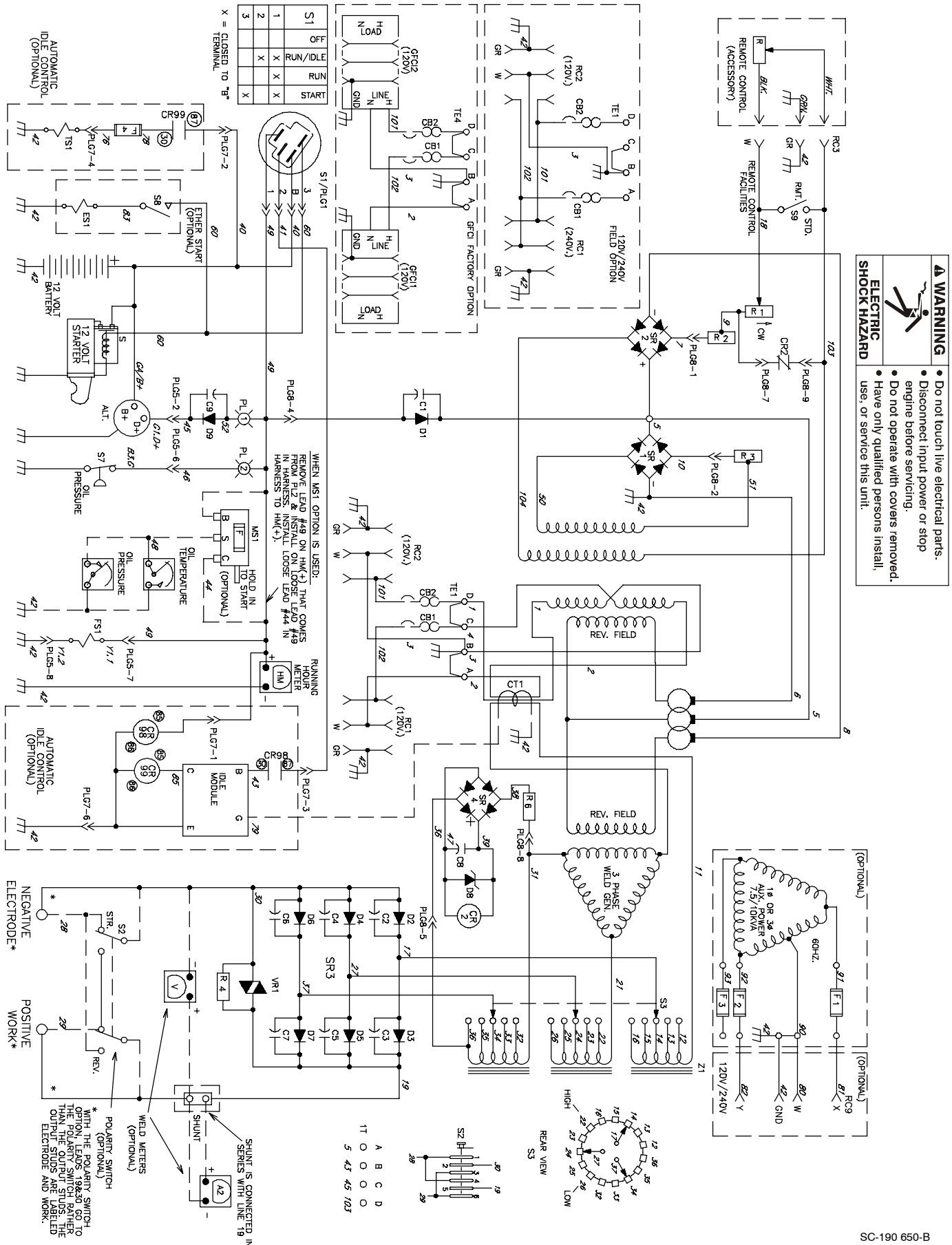
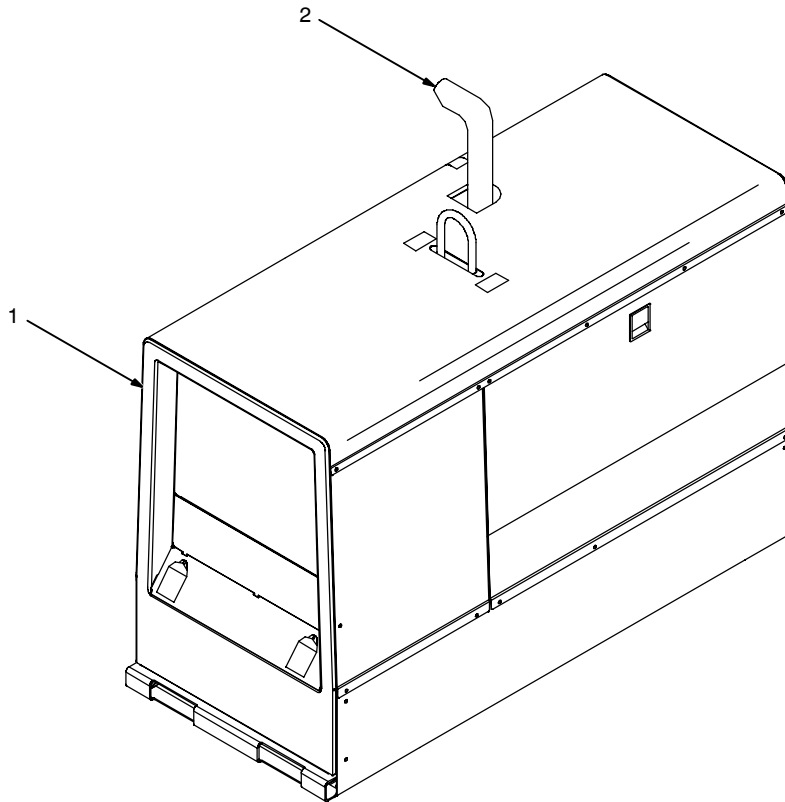

Figure 9-1. Circuit Diagram For Welding Generator

SECTION 10 – RUN-IN PROCEDURE

run_in1 8/01

10-1. Wetstacking



▲ **Do not perform run-in procedure at less than 20 volts weld output and do not exceed duty cycle or equipment damage may occur.**

1 Welding Generator

Run diesel engines near rated voltage and current during run-in period to properly seat piston rings and prevent wetstacking. See nameplate, rating label, or specifications section in this manual to find rated voltage and current.

☞ *Do not idle engine longer than necessary. Piston rings seat faster if engine runs at weld/power rpm, and the welding generator is kept loaded during run-in.*

2 Engine Exhaust Pipe

Wetstacking is unburned fuel and oil in the exhaust pipe and occurs during run-in if the engine is run too long at light load or idle rpm.

If exhaust pipe is coated with a wet, black, tar-like substance, dry the engine using one of the following run-in procedures.

See the engine manual for additional engine run-in information.

10-2. Run-In Procedure Using Load Bank

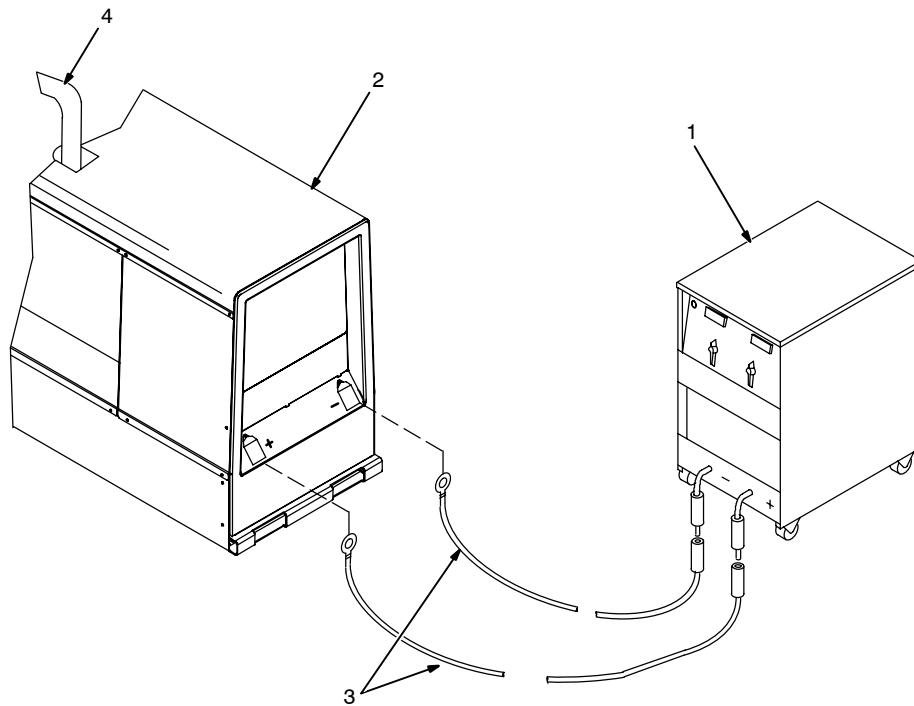

- ▲ **Stop engine.**
- ▲ **Do not touch hot exhaust pipe, engine parts, or load bank/grid.**
- ▲ **Keep exhaust and pipe away from flammables.**
- ▲ **Do not perform run-in procedure at less than 20 volts weld output and do not exceed duty cycle or equipment damage may occur.**

1 Load Bank

Turn all load bank switches Off. If needed, connect load bank to 115 volts ac wall receptacle or generator auxiliary power receptacle.

2 Welding Generator

Place A/V range switch in maximum position, A/V control in minimum position, and Output Selector switch (if present) in either DC position.

3 Weld Cables

Connect load bank to generator weld output terminals using proper size weld cables with correct connectors. Observe correct polarity.

Start engine and run for several minutes.

Set load bank switches and then adjust generator A/V control so load equals rated voltage and current of generator (see nameplate, rating label, or the specifications section in this manual).

Check generator and load bank meters after first five minutes then every fifteen minutes to be sure generator is loaded properly.

☞ Check oil level frequently during run-in; add oil if needed.

After one hour (minimum) place A/V control in minimum position, then turn off load bank to remove load. Run engine several minutes at no load.

- ▲ **Stop engine and let cool.**

4 Engine Exhaust Pipe

Repeat procedure if wetstacking is present.

10-3. Run-In Procedure Using Resistance Grid

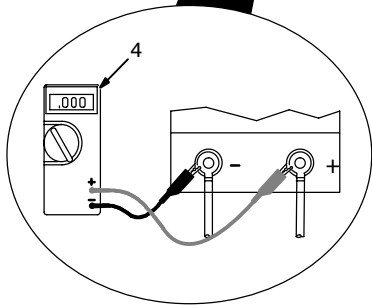
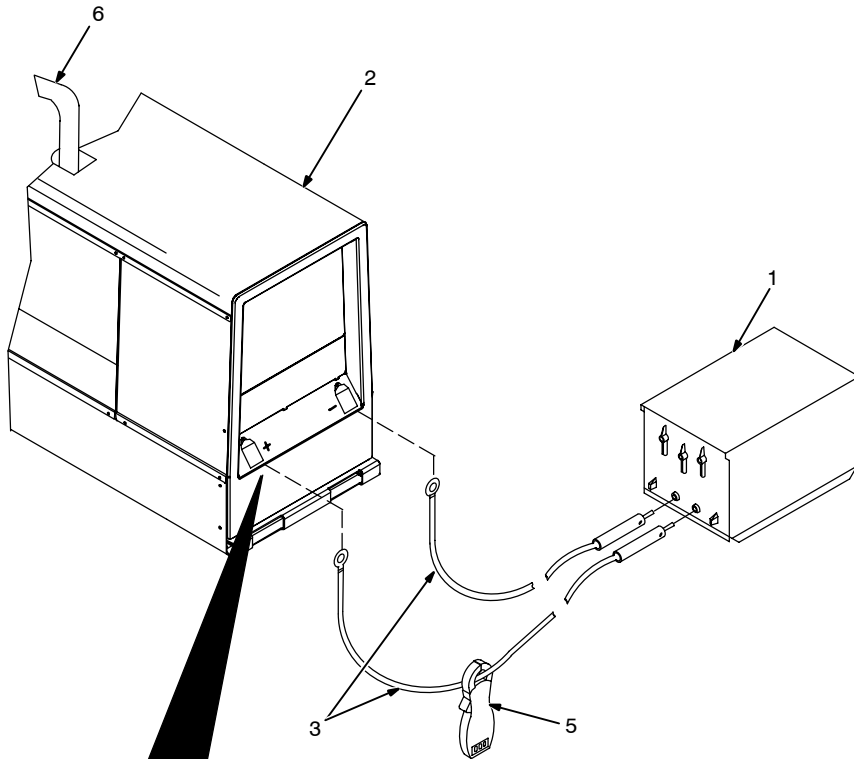

- ▲ **Stop engine.**
- ▲ **Do not touch hot exhaust pipe, engine parts, or load bank/grid.**
- ▲ **Keep exhaust and pipe away from flammables.**
- ▲ **Do not perform run-in procedure at less than 20 volts weld output and do not exceed duty cycle or equipment damage may occur.**

1 Resistance Grid

Use grid sized for generator rated output.

Turn Off grid.

2 Welding Generator

Place A/V range switch in maximum position, A/V control in minimum position, and Output Selector switch (if present) in either DC position.

3 Weld Cables

Connect grid to generator weld output terminals using proper size weld cables with correct connectors (polarity is not important).

4 Voltmeter

5 Clamp-On Ammeter

Connect voltmeter and ammeter as shown, if not provided on generator.

Start engine and run for several minutes.

Set grid switches and then adjust generator A/V control so load equals rated voltage and current of the generator (see nameplate, rating label, or the specifications section in this manual).

Check generator and meters after first five minutes then every fifteen minutes to be sure generator is loaded properly.

☞ *Check oil level frequently during run-in; add oil if needed.*

After one hour (minimum), place A/V control in minimum position, then shut down grid to remove load. Run engine several minutes at no load.

▲ **Stop engine and let cool.**

6 Engine Exhaust Pipe



Repeat procedure if wetstacking is present.

SECTION 11 – GENERATOR POWER GUIDELINES

NOTE

The views in this section are intended to be representative of all engine-driven welding generators. Your unit may differ from those shown.

11-1. Selecting Equipment





- 1 Generator Power Receptacles – Neutral Bonded To Frame
- 2 3-Prong Plug From Case Grounded Equipment
- 3 2-Prong Plug From Double Insulated Equipment

▲ **Do not use 2-prong plug unless equipment is double insulated.**

gen_pwr 11/02 – Ref. ST-159 730 / ST-800 577

11-2. Grounding Generator To Truck Or Trailer Frame

Electrically bond generator frame to vehicle frame by metal-to-metal contact.

▲ **Always ground generator frame to vehicle frame to prevent electric shock and static electricity hazards.**

- 1 Equipment Grounding Terminal (On Front Panel)
- 2 Grounding Cable (Not Supplied)
- 3 Metal Vehicle Frame

Connect cable from equipment ground terminal to metal vehicle frame. Use #10 AWG or larger insulated copper wire.

▲ **If unit does not have GFCI receptacles, use GFCI-protected extension cord.**

▲ **Bed liners, shipping skids, and some running gear insulate the welding generator from the vehicle frame. Always connect a ground wire from the generator equipment grounding terminal to bare metal on the vehicle frame as shown.**

S-0854

11-3. Grounding When Supplying Building Systems

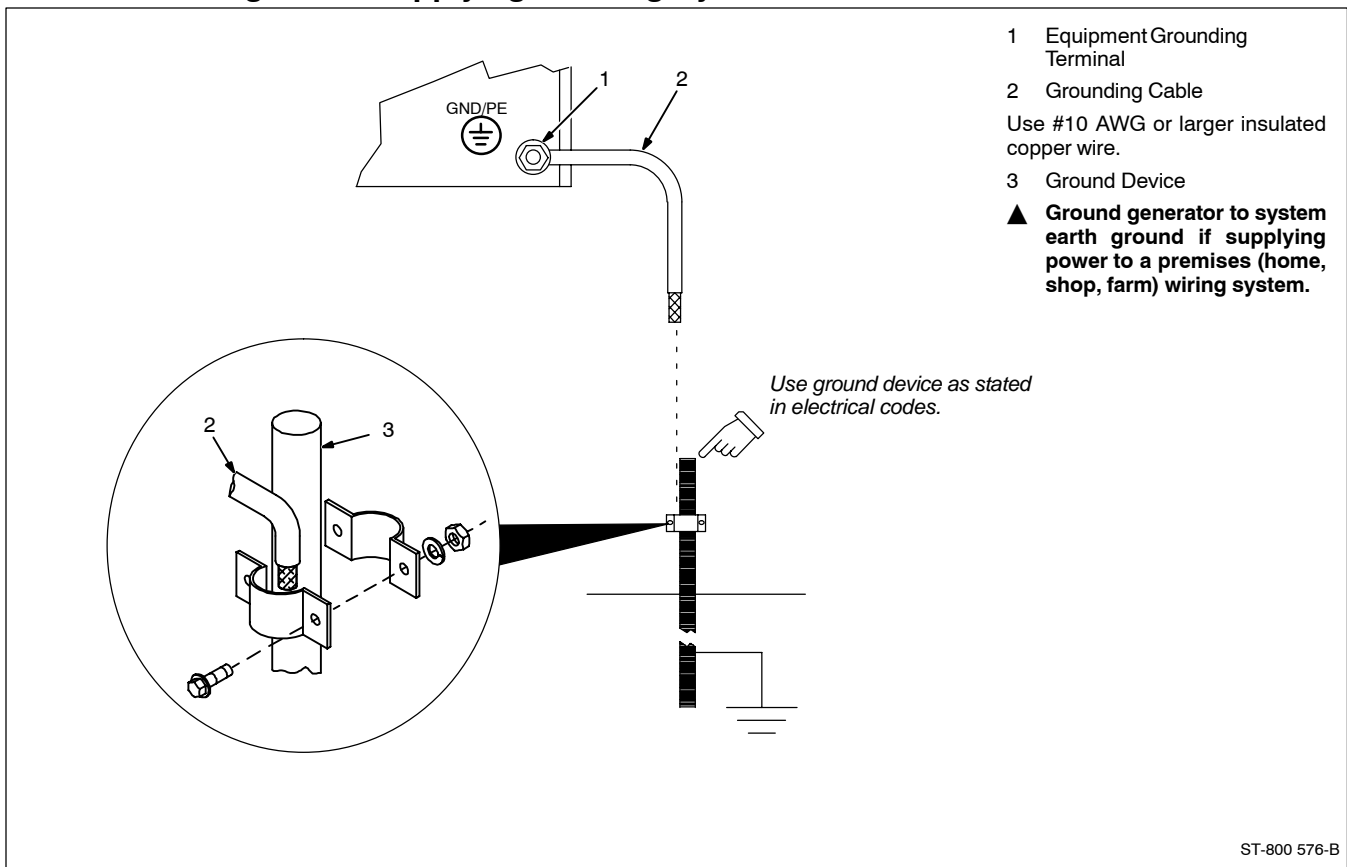

11-4. How Much Power Does Equipment Require?

1 Resistive Load
 A light bulb is a resistive load and requires a constant amount of power.

2 Non-Resistive Load
 Equipment with a motor is a non-resistive load and requires approximately six times more power while starting the motor than when running (see Section 11-8).

3 Rating Data
 Rating shows volts and amperes, or watts required to run equipment.

AMPERES x VOLTS = WATTS

EXAMPLE 1: If a drill uses 4.5 amperes at 115 volts, calculate its running power requirement in watts.

$4.5 \text{ A} \times 115 \text{ V} = 520 \text{ W}$

The load applied by the drill is 520 watts.

EXAMPLE 2: If three 200 watt flood lamps are used with the drill from Example 1, add the individual loads to calculate total load.

$(200 \text{ W} + 200 \text{ W} + 200 \text{ W}) + 520 \text{ W} = 1120 \text{ W}$

The total load applied by the three flood lamps and drill is 1120 watts.

S-0623

11-5. Approximate Power Requirements For Industrial Motors

Industrial Motors	Rating	Starting Watts	Running Watts
Split Phase	1/8 HP	800	300
	1/6 HP	1225	500
	1/4 HP	1600	600
	1/3 HP	2100	700
	1/2 HP	3175	875
Capacitor Start-Induction Run	1/3 HP	2020	720
	1/2 HP	3075	975
	3/4 HP	4500	1400
	1 HP	6100	1600
	1-1/2 HP	8200	2200
	2 HP	10550	2850
	3 HP	15900	3900
Capacitor Start-Capacitor Run	5 HP	23300	6800
	1-1/2 HP	8100	2000
	5 HP	23300	6000
	7-1/2 HP	35000	8000
Fan Duty	10 HP	46700	10700
	1/8 HP	1000	400
	1/6 HP	1400	550
	1/4 HP	1850	650
	1/3 HP	2400	800
	1/2 HP	3500	1100

11-6. Approximate Power Requirements For Farm/Home Equipment

Farm/Home Equipment	Rating	Starting Watts	Running Watts
Stock Tank De-Icer		1000	1000
Grain Cleaner	1/4 HP	1650	650
Portable Conveyor	1/2 HP	3400	1000
Grain Elevator	3/4 HP	4400	1400
Milk Cooler		2900	1100
Milker (Vacuum Pump)	2 HP	10500	2800
FARM DUTY MOTORS	1/3 HP	1720	720
Std. (e.g. Conveyors,	1/2 HP	2575	975
Feed Augers, Air	3/4 HP	4500	1400
Compressors)	1 HP	6100	1600
	1-1/2 HP	8200	2200
	2 HP	10550	2850
	3 HP	15900	3900
	5 HP	23300	6800
High Torque (e.g. Barn	1-1/2 HP	8100	2000
Cleaners, Silo Unloaders,	5 HP	23300	6000
Silo Hoists, Bunk Feeders)	7-1/2 HP	35000	8000
	10 HP	46700	10700
3-1/2 cu. ft. Mixer	1/2 HP	3300	1000
High Pressure 1.8 Gal/Min	500 PSI	3150	950
Washer 2 gal/min	550 PSI	4500	1400
2 gal/min	700 PSI	6100	1600
Refrigerator or Freezer		3100	800
Shallow Well Pump	1/3 HP	2150	750
	1/2 HP	3100	1000
Sump Pump	1/3 HP	2100	800
	1/2 HP	3200	1050

11-7. Approximate Power Requirements For Contractor Equipment

Contractor	Rating	Starting Watts	Running Watts
Hand Drill	1/4 in	350	350
	3/8 in	400	400
	1/2 in	600	600
Circular Saw	6-1/2 in	500	500
	7-1/4 in	900	900
	8-1/4 in	1400	1400
Table Saw	9 in	4500	1500
	10 in	6300	1800
Band Saw	14 in	2500	1100
Bench Grinder	6 in	1720	720
	8 in	3900	1400
	10 in	5200	1600
Air Compressor	1/2 HP	3000	1000
	1 HP	6000	1500
	1-1/2 HP	8200	2200
	2 HP	10500	2800
Electric Chain Saw	1-1/2 HP, 12 in	1100	1100
	2 HP, 14 in	1100	1100
Electric Trimmer	Standard 9 in	350	350
	Heavy Duty 12 in	500	500
Electric Cultivator	1/3 HP	2100	700
Elec. Hedge Trimmer	18 in	400	400
Flood Lights	HID	125	100
	Metal Halide	313	250
	Mercury	1000	
	Sodium Vapor	1400	1000
Submersible Pump	400 gph	600	200
Centrifugal Pump	900 gph	900	500
Floor Polisher	3/4 HP, 16 in	4500	1400
	1 HP, 20 in	6100	1600
High Pressure Washer	1/2 HP	3150	950
	3/4 HP	4500	1400
	1 HP	6100	1600
55 gal Drum Mixer	1/4 HP	1900	700
Wet & Dry Vac	1.7 HP	900	900
	2-1/2 HP	1300	1300

11-8. Power Required To Start Motor

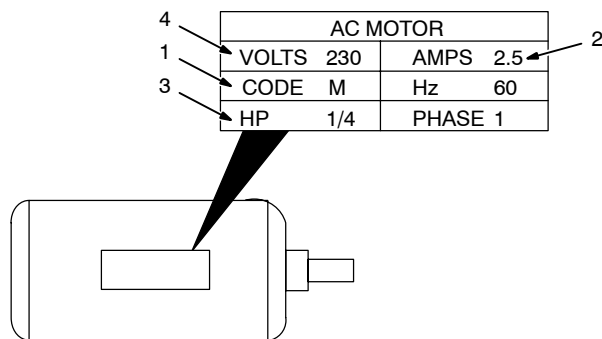

- 1 Motor Start Code
- 2 Running Amperage
- 3 Motor HP
- 4 Motor Voltage

To find starting amperage:

Step 1: Find code and use table to find kVA/HP. If code is not listed, multiply running amperage by six to find starting amperage.

Step 2: Find Motor HP and Volts.

Step 3: Determine starting amperage (see example).

Welding generator amperage output must be at least twice the motor's running amperage.

Single-Phase Induction Motor Starting Requirements

Motor Start Code	G	H	J	K	L	M	N	P
KVA/HP	6.3	7.1	8.0	9.0	10.0	11.2	12.5	14.0

$$\frac{\text{kVA/HP} \times \text{HP} \times 1000}{\text{VOLTS}} = \text{STARTING AMPERAGE}$$

EXAMPLE: Calculate the starting amperage required for a 230 V, 1/4 HP motor with a motor start code of M.

Volts = 230 HP = 1/4 Using Table, Code M results in kVA/HP = 11.2

$$\frac{11.2 \times 1/4 \times 1000}{230} = 12.2 \text{ A} \quad \text{Starting the motor requires 12.2 amperes.}$$

S-0624

11-9. How Much Power Can Generator Supply?

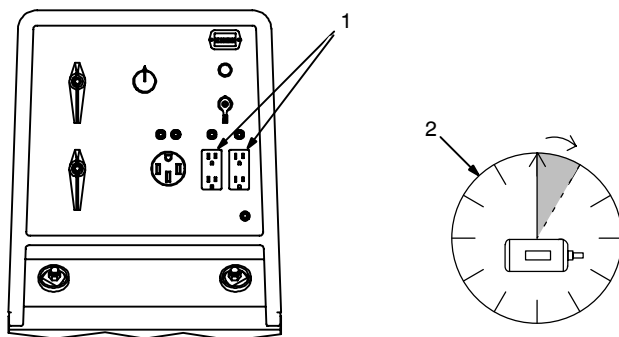

- 1 Limit Load To 90% Of Generator Output

Always start non-resistive (motor) loads in order from largest to smallest, and add resistive loads last.

- 2 5 Second Rule

If motor does not start within 5 seconds, turn off power to prevent motor damage. Motor requires more power than generator can supply.

Ref. ST-800 396-A / S-0625

11-11. Selecting Extension Cord (Use Shortest Cord Possible)



Cord Lengths for 120 Volt Loads

▲ If unit does not have GFCI receptacles, use GFCI-protected extension cord.

Current (Amperes)	Load (Watts)	Maximum Allowable Cord Length in ft (m) for Conductor Size (AWG)*					
		4	6	8	10	12	14
5	600			350 (106)	225 (68)	137 (42)	100 (30)
7	840		400 (122)	250 (76)	150 (46)	100 (30)	62 (19)
10	1200	400 (122)	275 (84)	175 (53)	112 (34)	62 (19)	50 (15)
15	1800	300 (91)	175 (53)	112 (34)	75 (23)	37 (11)	30 (9)
20	2400	225 (68)	137 (42)	87 (26)	50 (15)	30 (9)	
25	3000	175 (53)	112 (34)	62 (19)	37 (11)		
30	3600	150 (46)	87 (26)	50 (15)	37 (11)		
35	4200	125 (38)	75 (23)	50 (15)			
40	4800	112 (34)	62 (19)	37 (11)			
45	5400	100 (30)	62 (19)				
50	6000	87 (26)	50 (15)				

*Conductor size is based on maximum 2% voltage drop

Cord Lengths for 240 Volt Loads

▲ If unit does not have GFCI receptacles, use GFCI-protected extension cord.

Current (Amperes)	Load (Watts)	Maximum Allowable Cord Length in ft (m) for Conductor Size (AWG)*					
		4	6	8	10	12	14
5	1200			700 (213)	450 (137)	225 (84)	200 (61)
7	1680		800 (244)	500 (152)	300 (91)	200 (61)	125 (38)
10	2400	800 (244)	550 (168)	350 (107)	225 (69)	125 (38)	100 (31)
15	3600	600 (183)	350 (107)	225 (69)	150 (46)	75 (23)	60 (18)
20	4800	450 (137)	275 (84)	175 (53)	100 (31)	60 (18)	
25	6000	350 (107)	225 (69)	125 (38)	75 (23)		
30	7000	300 (91)	175 (53)	100 (31)	75 (23)		
35	8400	250 (76)	150 (46)	100 (31)			
40	9600	225 (69)	125 (38)	75 (23)			
45	10,800	200 (61)	125 (38)				
50	12,000	175 (53)	100 (31)				

*Conductor size is based on maximum 2% voltage drop

SECTION 12 – PARTS LIST

☞ Hardware is common and not available unless listed.

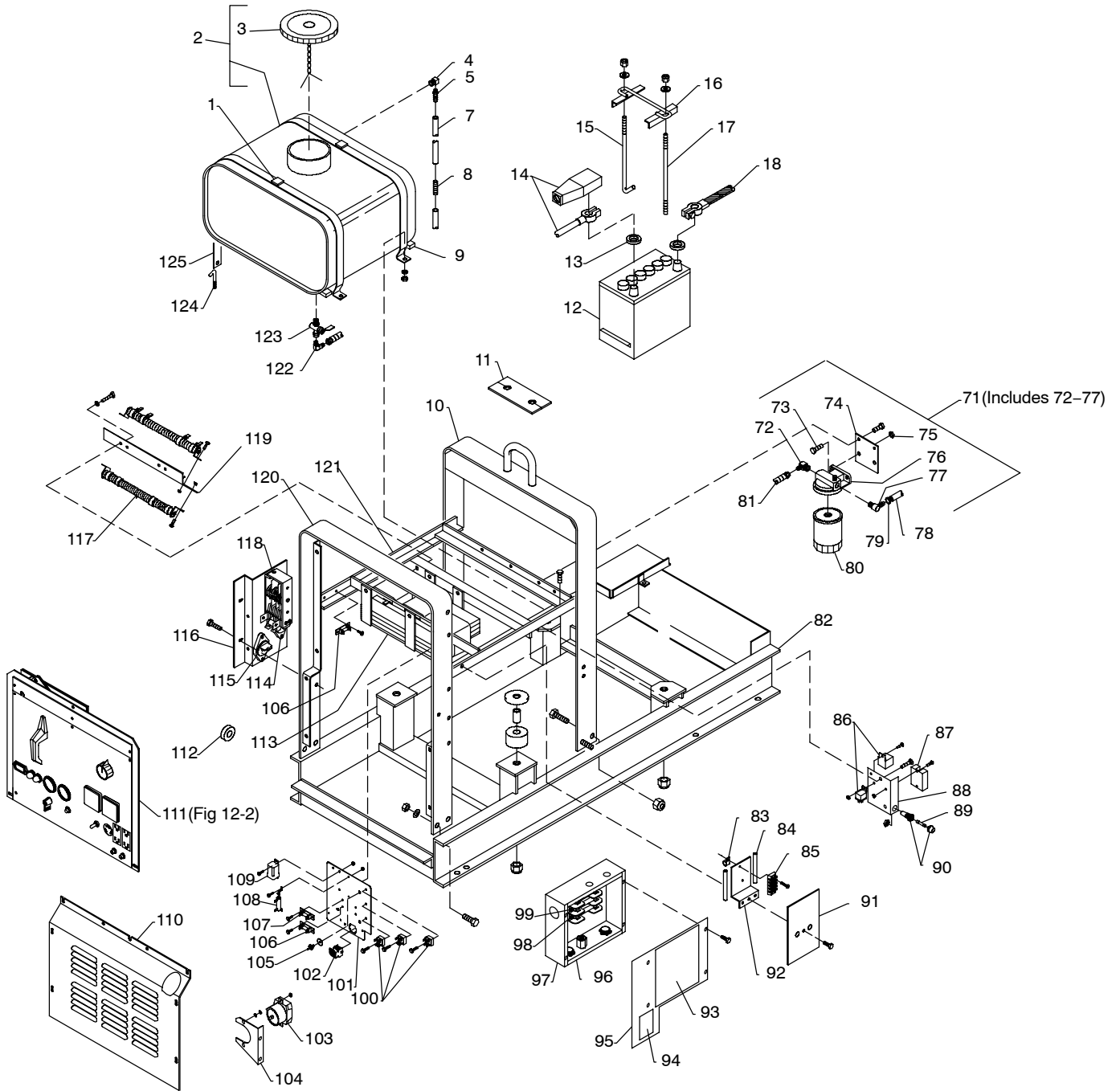
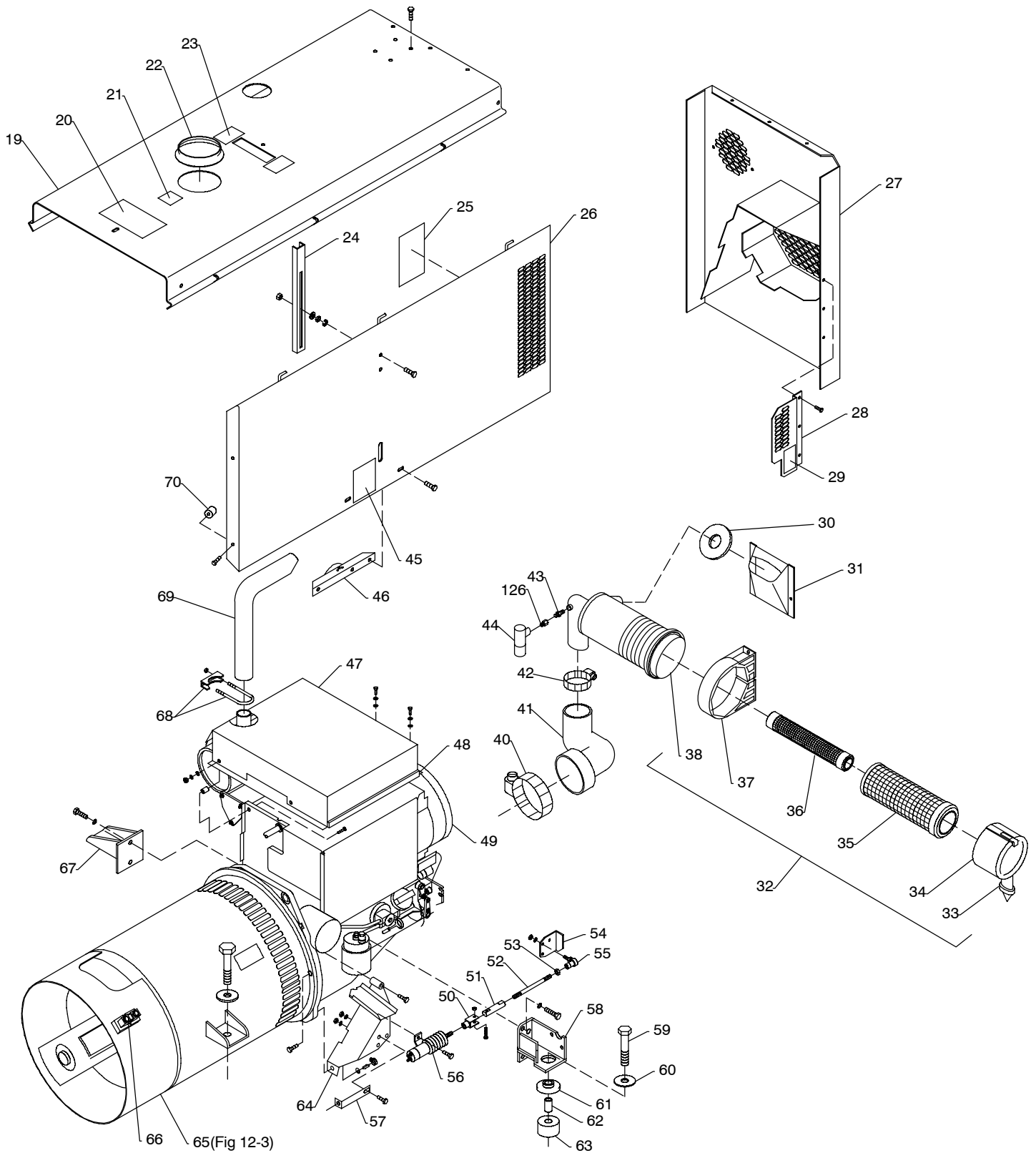

Figure 12-1. Main Assembly



ST-129 956-U

Item No.	Dia. Mkgs.	Part No.	Description	Quantity
Figure 12-1. Main Assembly				
1		134 771	PLUG, protective .640sq	2
2		184 676	TANK, fuel (consisting of)	1
3		182 022	CAP, fuel large	1
		605 288	FITTING, pipe galv plug sqhd .250NPT	1
4		020 185	FITTING, pipe brs elbow st 1/8NPT	1
5		073 432	FITTING, brs barbed M 3/16tbg x 1/8NPT	1
6		Deleted		
7		125 687	HOSE, nprn SAE .125 ID x .343 OD (order by ft)	1ft
8		192 757	FITTING, hose brs splice 3/16 tbg x 3/16 tbg	1
9		097 507	STRIP, rbr adh back 1.125 x 1.000 x 20.500	2
10		188 235	UPRIGHT, base center	1
11		017 479	SEAL, weather lift eye	1
12		111 352	BATTERY, stor 12V 380crk 80rsv	1
13		108 081	TERMINAL PROTECTOR, battery post mtg	2
14		124 941	CABLE, bat pos	1
15		089 914	BOLT, L stl .312-18 x 10.000	1
16		124 668	HOLD DOWN, battery	1
17		010 460	STUD, stl .312-18 x 10.000	1
18		032 453	CABLE, bat neg	1
		049 026	SCREW, M10-1.5 x 25mm hexhd	1
19		+124 766	COVER, top	1
20		134 792	LABEL, warning general precautionary	1
21		107 990	LABEL, use diesel fuel only	1
22		035 968	WASHER, flat rbr 3.625 ID x 5.875 OD x .062thk	1
		195 869	CABLE TIE, 0-17.500 weather resistant	1
23		108 487	LABEL, warning falling equipment can cause serious injury	2
24		004 130	BRACKET, support door	2
25		173 847	LABEL, diesel engine maintenance	1
26		+124 687	DOOR, side RH	1
		+124 685	DOOR, side LH	1
		168 385	LABEL, warning battery explosion can blind	1
		089 343	RIVET, nyl .250dia x 1.000 lg	6
27		178 763	PANEL, rear	1
28		+162 741	GUARD, belt	1
29		146 994	LABEL, warning moving parts can cause serious injury	1
30		107 343	GROMMET, rbr neck	1
31		197 614	AIR BOX	1
32		197 613	AIR CLEANER, intake (consisting of)	1
33		197 675	DUST EJECTOR, air cleaner	1
34		197 677	COVER ASSY, air cleaner	1
35		*197 676	ELEMENT, air cleaner	1
36		◆197 679	ELEMENT, air cleaner safety	1
37		197 829	BRACKET, mtg air cleaner	2
38		197 678	BODY, air cleaner	1
39		Deleted		
40		010 863	CLAMP, hose 2.062 - 3.000clp dia	1
41		124 985	HOSE, air cleaner to engine	1
42		010 862	CLAMP, 1.812 - 2.500clp dia	1
43		◆010 089	FITTING, pipe brs coupling 1/8NPT	1
44		◆046 545	RESTRICTION INDICATOR	1
45		158 610	LABEL, warning electric shock and moving parts	2
46		087 336	LATCH	2
47		173 908	BAFFLE, air	1
		010 736	TUBING, stl .625 OD x 12ga wall x .625	1
48		173 910	WEATHERSTRIPPING	1
49		173 943	ENGINE, Deutz dsl elec	1
	PLG5	173 916	CONN, RECT HOUSING 10 CIRCUIT	1
		173 935	TERMINAL, Receptacle Mini Spring	4

Item No.	Dia. Mkgs.	Part No.	Description	Quantity
Figure 12-1. Main Assembly				
		128 287	STUD, adjusting throttle	1
50		◆127 648	CLEVIS, throttle	1
51		◆127 994	BALL JOINT, .250-28	1
52		◆175 936	ROD, throttle	1
53		◆126 388	NUT, .250-28 LH	1
54		◆194 036	BRACKET, arm throttle	1
		◆010 021	CLAMP, stl cush .562dia x .343mtg hole	1
		◆072 082	BUSHING, stl .265 ID x .499 OD x .593 lg	2
		◆118 679	SCREW, M 6-1.0 x 30	2
55		◆125 663	BALL JOINT, .250-28 LH	1
56	TS1	◆124 974	SOLENOID, 12VDC	1
57		◆175 937	BRACKET, support solenoid	1
58		188 246	BRACKET, mtg engine RH	1
59		601 945	SCREW, cap stl hexhd .625-18 x 4.000	4
60		071 731	WASHER,flat stl .656 ID x 2.250 OD x .187thk	4
61		071 890	RETAINER, mount eng/gen	4
62		071 730	TUBING, stl .875 OD x 12ga wall x 2.375	4
63		072 848	TUBING, nprn .875 ID x 2.500 OD x 2.000	4
64		173 929	BRACKET, mtg solenoid	1
65		Fig 12-3	GENERATOR	1
66		◆030 084	SHUNT, meter 50MV 600A	1
67		188 239	BRACKET, mtg engine LH	1
68		109 591	CLAMP, muffler 1.750dia	1
69		124 866	PIPE, muffler extension elb	1
70		087 341	BUMPER, door 1.000 OD x .750 high	4
71		200 788	BASE, filter fuel (standard models – includes items 72 thru 77)	1
		208 858	BASE, filter fuel (models w/ 7.5/10 KVA opt. – incl items 72 thru 77)	1
72		110 069	FITTING, flrd brs elbow M 1/4	1
		106 394	FITTING, flrd brs conn M HD 1/4 tbg x 1/4 NPT(7.5/10 KVA option)	1
73		080 389	SCREW, .312-18 x 1.000 cap hexhd	2
74		124 607	STRIP, mtg separator fuel	1
75		172 684	NUT, .312-18 x .50 hex	2
76		200 787	BASE, filter w/adapter and vent	1
77		145 282	FITTING, hose brs barbed elb M 5/16tbg x 1/4NPT	1
78		134 835	HOSE, SAE .312 ID x .560 OD (order by ft)	2ft
79		010 323	CLAMP, hose .250-.625clp dia	2
80		192 744	FILTER, fuel spin-on	1
81		145 283	HOSE, fuel 10.000 1/4 swivel both ends	1
82		188 250	BASE	1
83		020 225	CLAMP, Nyl .875 Clamp Dia X.500 Wide	1
84		123 794	EDGE TRIM, (order by ft)	1ft
85	TE1	038 621	BLOCK, term 30A 4P	1
		038 620	LINK, jumper term blk 30A	2
	PLG7	◆135 556	CONNECTOR & SOCKETS	1
86	CR98, CR99	◆090 104	RELAY, encl 12VDC SPST	2
87	Idle mod	◆189 742	MODULE, pull to idle 5 pin	1
88		◆176 775	BRACKET, mtg comp panel auto idle	1
89	F4	◆073 429	FUSE, mintr gl slo-blo 15A 32V	1
90		◆046 432	HOLDER, fuse mintr .250 x 1.250 panel mtg	1
91		053 967	INSULATION, rectifier	1
92		081 499	BRACKET, mtg strip terminal	1
93		179 637	LABEL, warning auxiliary power	1
94		113 730	LABEL, warning stop engine	1
95		+◆173 410	COVER, fuse box	1
96		◆026 947	STAND-OFF, insulator	1
97		◆134 903	FUSE BOX	1
98		◆149 541	HOLDER, fuse crtg 60A 250V	1
99		*◆089 585	FUSE, crtg 35A 250V	3
100	SR1,2,4	035 704	RECTIFIER, integ 40A 800V	3

Item No.	Dia. Mkgs.	Part No.	Description	Quantity
Figure 12-1. Main Assembly				
101		173 982	PANEL, mtg components	1
102	RC9	168 071	CONNECTOR & SOCKETS	1
103		◆173 423	RECEPTACLE, 3P 50A 125/250V	1
		123 794	EDGE TRIM, (order by ft)	1ft
104		◆173 408	BRACKET, mtg receptacle	1
105	D8	192 307	KIT, diode w/washers	1
106	D1/C1, D9/C9	189 701	DIODE/CAPACITOR BOARD	2
107	C8	170 674	CAPACITOR BOARD	1
108	R6	030 844	RESISTOR, WW fxd 25W 25 ohm	1
		605 741	CLIP, mtg resistor	2
109	CR2	044 588	RELAY, encl 12VDC 3PDT	1
110		+173 317	PANEL, front lower	1
110		+◆175 368	PANEL, front lower	1
111		Fig 11-2	PANEL, front w/components	1
112	CT1	◆105 370	TRANSFORMER, current	1
113	Z1	204 797	REACTOR	1
114	Neg	039 046	TERMINAL, pwr output black	1
115	Pos	039 047	TERMINAL, pwr output red	1
116		◆174 008	BRACKET, mtg switch and output terminals	1
117	R2,3	189 699	RESISTOR, WW tap 375W 10 ohm w/mounting bracket	2
118		◆174 010	SWITCH, polarity	1
		◆059 773	HANDLE, switch	1
119		085 656	STRIP, mtg resistor	1
120		188 237	UPRIGHT, base front	1
121		108 163	FRAME, mtg reactor & fuel tank	1
122		110 069	FITTING, brs fird elbow M 1/4tbg x 1/4NPT	2
123		010 314	VALVE, shut-off fuel	1
124		070 010	BOLT, J stl .250-20 x 2.750	4
125		089 517	STRAP, fuel tank	2
126		◆175 465	FITTING, pipe brs adapter extender 1/8 x 1/8 120	1
		173 919	KIT, label	1
		168 071	CONNECTOR & SOCKETS	2
		165 669	CONNECTOR & SOCKETS	1
		116 045	CONNECTOR & SOCKETS	1

◆OPTIONAL

+When ordering a component originally displaying a precautionary label, the label should also be ordered.

*Recommended Spare Parts.

To maintain the factory original performance of your equipment, use only Manufacturer's Suggested Replacement Parts. Model and serial number required when ordering parts from your local distributor.

Item No.	Dia. Mkgs.	Part No.	Description	Quantity
----------	------------	----------	-------------	----------

Figure 12-2. Panel, Front w/Components (Fig 12-1 Item 111)

1	S3	114 193	SWITCH, range (Fig 11-4)	1
2	R1	605 960	RHEOSTAT, WW 300W 34 ohm	1
3	MS1	◆011 072	SWITCH, magnetic (consisting of)	1
	F	*048 317	FUSE, mintr gl 14A 32V	1
4		011 609	SWITCH, tgl SPDT 15A 125V	1
5		032 897	RECEPTACLE, twlk grd 2P3W 15A 125V	1
6	CB1,2	139 266	CIRCUIT BREAKER, man reset 1P 15A 250VAC	2
7	RC1,2	170 901	RECEPTACLE, str dx grd 2P3W 15A 125V	2
7	GFCI1, 2	◆151 981	RECEPTACLE, str dx grd 2P3W 15/20A GFCI	2
		073 690	PLUG, str grd 2P3W 15A 125V Arrow Hart 5965V	
8		601 836	NUT, brs hex .250-20 jam hvv	3
9		083 030	STUD, brs grd .250-20 x 1.750	1
10			PLATE, ident control rating (order by model and serial number)	1
11		◆046 652	METER, amp DC 50MV 0-600	1
12		◆046 654	METER, volt DC 0-100	1

Item No.	Dia. Mkgs.	Part No.	Description	Quantity
----------	------------	----------	-------------	----------

Figure 12-2. Panel, Front w/Components (Fig 12-1 Item 111) (Cont'd)

13		021 385	.. BOOT, toggle switch lever	2
14		◆129 860	.. GAUGE, oil pressure	1
		◆128 829	.. KIT, oil line 44.000 in 1/8NPT x 10mm	1
		◆128 633	.. FITTING, pipe brs adapter 1/8NPT x 12mm	1
15		◆129 837	.. GAUGE, engine temperature	1
16		119 014	.. LEVER, switch black	1
17		082 789	.. LENS, light ind red	2
18	PL1,2	*048 155	.. BULB, incand flg base 12V	2
19		082 788	.. HOLDER, light ind	2
20	HM	145 247	.. METER, hour 4-40VDC	1
21		019 602	.. KNOB, pointer	1
22		019 754	.. HANDLE, switch range	1
23			.. NAMEPLATE, (order by model and serial number)	1
24	S1	176 606	.. SWITCH, ignition 4posn	1
25		127 618	.. PANEL, front upper	1
26		189 404	.. SPACER, nylon	1

☞ Hardware is common and not available unless listed.

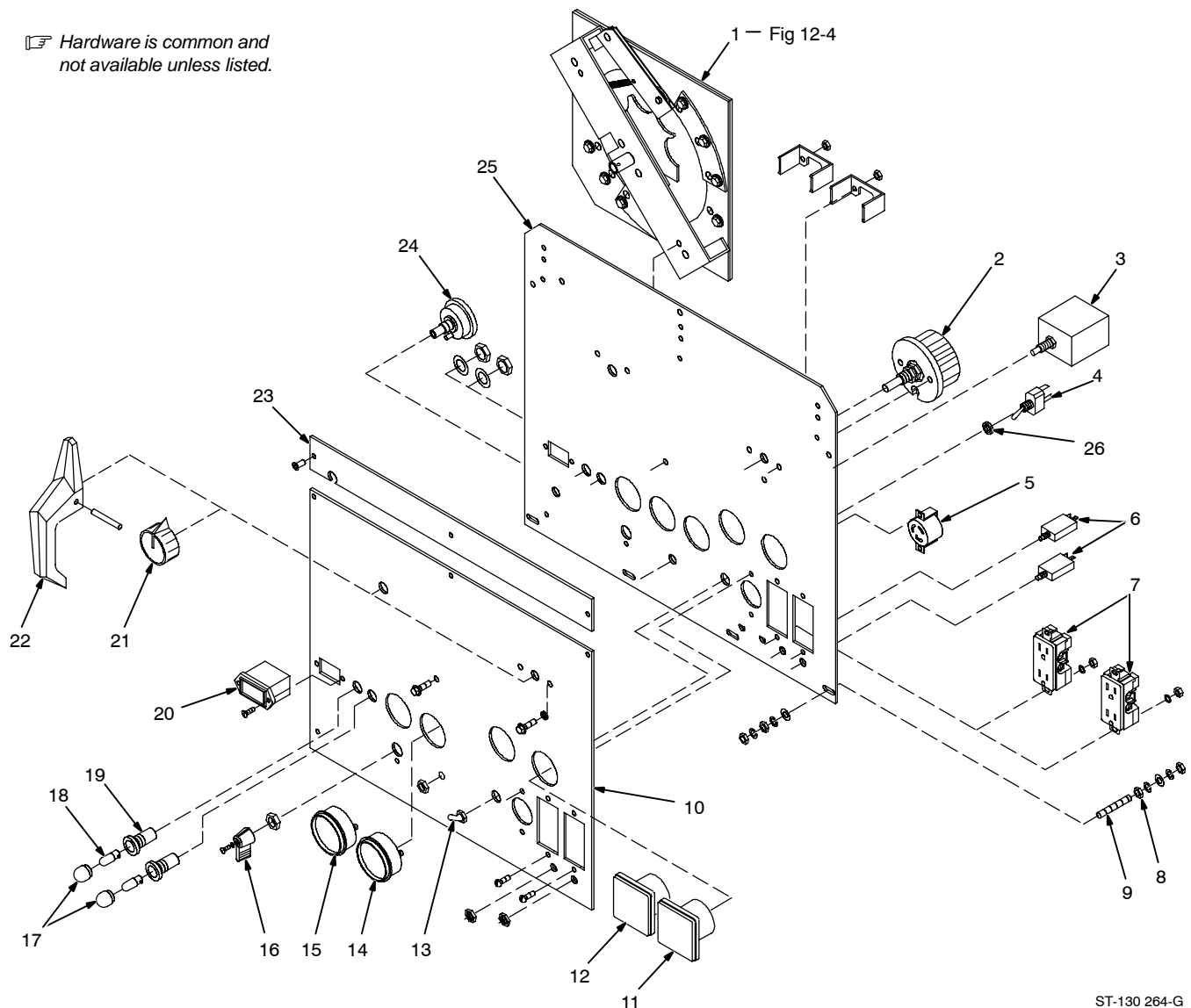

Figure 12-2. Panel, Front w/Components

ST-130 264-G

◆ OPTIONAL

*Recommended Spare Parts.

To maintain the factory original performance of your equipment, use only Manufacturer's Suggested Replacement Parts. Model and serial number required when ordering parts from your local distributor.

☐ Hardware is common and not available unless listed.

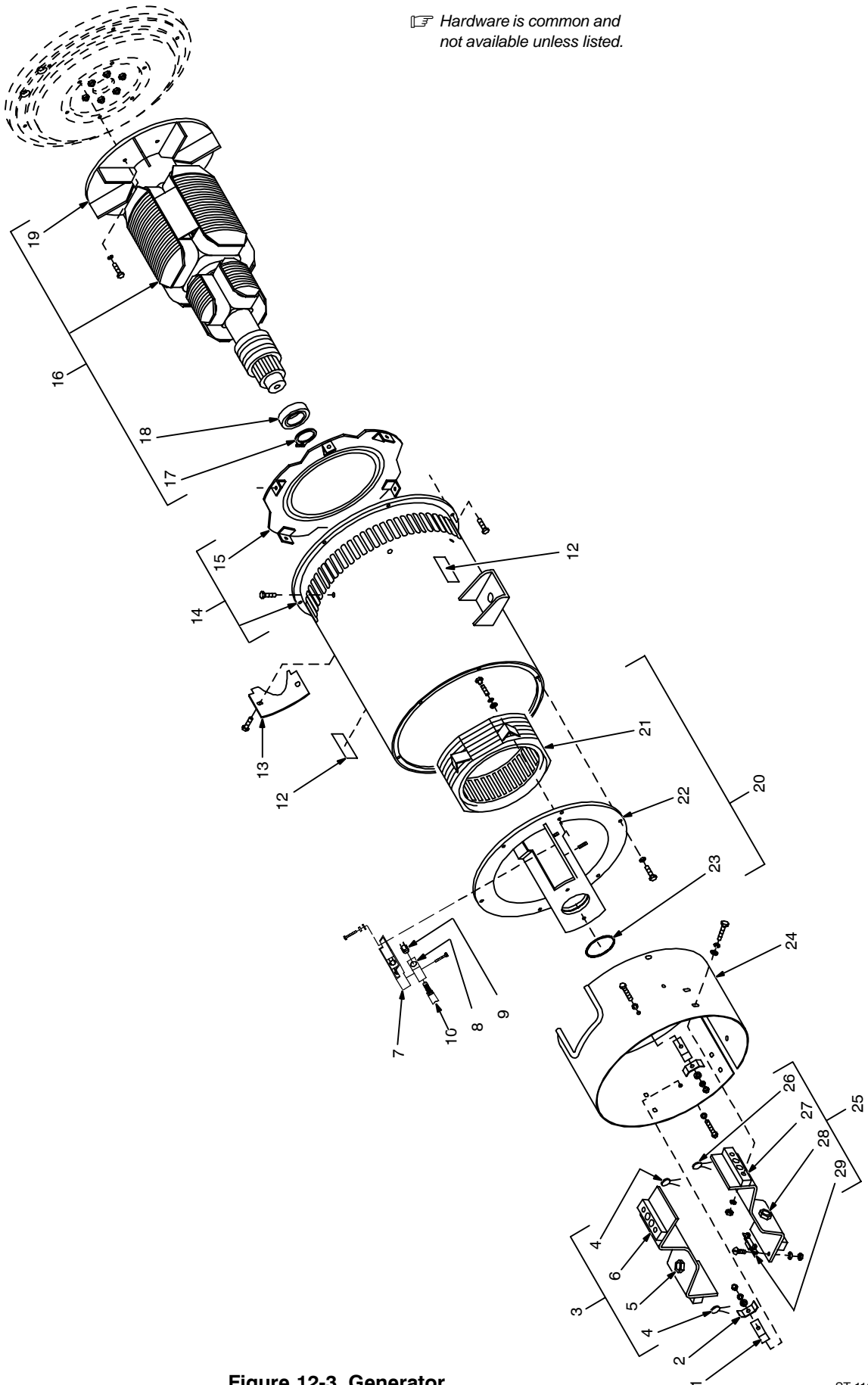

Figure 12-3. Generator

Item No.	Dia. Mkgs.	Part No.	Description	Quantity
Figure 12-3. Generator (Fig 12-1 Item 65)				
1		106 426	INSULATOR	4
2		106 440	BUS BAR, rectifier	2
3	SR3	106 427	DIODE ASSEMBLY, reverse polarity (consisting of)	1
4		048 420	CAPACITOR, rectifier	2
		106 641	CAPACITOR	1
5		037 957	DIODE, rect 275A 300V RP	3
6		106 425	INSULATOR	2
		188 387	BRUSHHOLDER/BRACKET ASSEMBLY, (consisting of)	3
7		173 066	BRACKET, mtg brushholder	1
8		600 270	HOLDER, brush	1
9		152 044	CAP, brushholder	1
10		*151 299	BRUSH, contact	1
11		Deleted		
12		013 367	LABEL, warning moving parts can cause serious injury	2
13		124 855	GUARD, starter	1
14		+204 693	STATOR, gen (consisting of)	1
14		+♦ 204 742	STATOR, gen (consisting of)	1
15		039 207	BAFFLE, air gen	1
16		204 682	ROTOR, gen (consisting of)	1
17		024 617	RING, retaining external	1
18		053 390	BEARING, ball	1
19		089 737	FAN, rotor	1
		035 776	KEY, .375 x .375 x 2.000	1
20		204 695	STATOR, exciter endbell (consisting of)	1
21		204 714	STATOR, exciter/aux power	1
22		173 068	ENDBELL, gen (consisting of)	1
23		143 220	O-RING, 2.859 ID x .139CS	1
24		173 323	BARREL, rectifier	1
25	SR3	106 430	DIODE ASSEMBLY, (consisting of)	1
26		048 420	CAPACITOR, rectifier	2
		106 641	CAPACITOR	1
27		106 425	INSULATOR	1
28		037 956	DIODE, rect 275A 300V SP	3
29	VR1,R4	046 819	SUPPRESSOR	1

♦ OPTIONAL

*Recommended Spare Parts.

+When ordering a component originally displaying a precautionary label, the label should also be ordered.

To maintain the factory original performance of your equipment, use only Manufacturer's Suggested Replacement Parts. Model and serial number required when ordering parts from your local distributor.

Item No.	Part No.	Description	Quantity
114 193 Figure 12-4. Switch, Range (Fig 12-2 Item 1)			
1	114 235	BRACKET, mtg switch (consisting of)	1
2	010 671	SPRING, ext x .312 OD x .042 wire x 1.875pld	1
3	017 428	LOCATOR, quadrant	1
4	004 998	CONTACT BOARD ASSEMBLY, switch range (consisting of)	1
5	011 980	CONTACT BOARD, movable switch	2
6	011 645	CONTACT ASSEMBLY, movable (consisting of)	3
7	011 076	SPRING, pressure	1
8	011 953	CONTACT	2
9	011 074	SPRING, pressure	1
10	011 644	CONTACT, stationary	15
11	004 999	CONTACT BOARD, stationary	2
12	011 012	SHIM, guide contact board	3
13	100 623	GUIDE, contact board movable	3

☞ Hardware is common and not available unless listed.

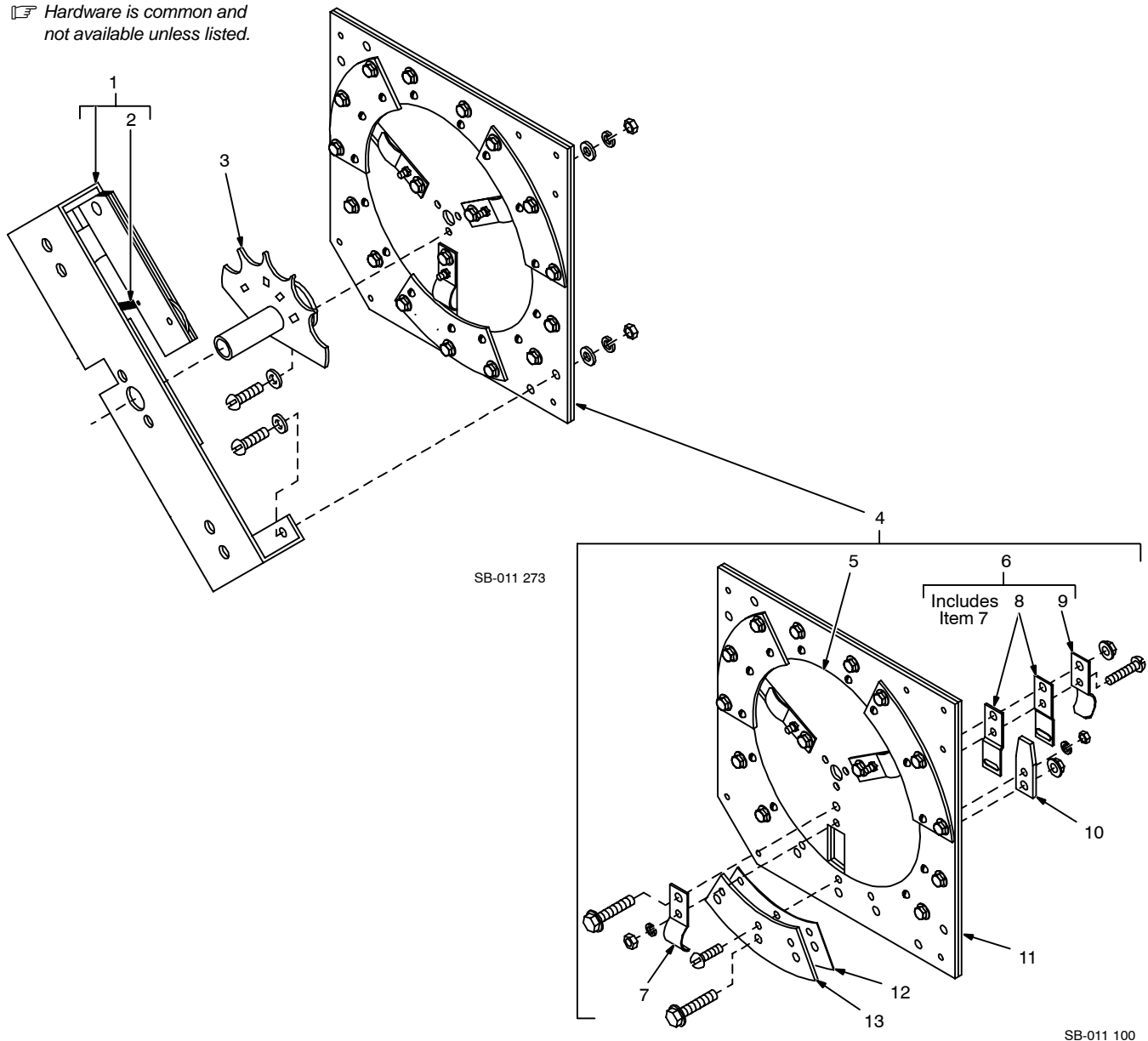

Figure 12-4. Switch, Range

To maintain the factory original performance of your equipment, use only Manufacturer's Suggested Replacement Parts. Model and serial number required when ordering parts from your local distributor.

TRUE BLUE[®]

WARRANTY

Effective January 1, 2005

(Equipment with a serial number preface of "LF" or newer)

This limited warranty supersedes all previous Miller warranties and is exclusive with no other guarantees or warranties expressed or implied.

Warranty Questions?

Call
1-800-4-A-MILLER
for your local
Miller distributor.

Your distributor also gives
you ...

Service

You always get the fast,
reliable response you
need. Most replacement
parts can be in your
hands in 24 hours.

Support

Need fast answers to the
tough welding questions?
Contact your distributor.
The expertise of the
distributor and Miller is
there to help you, every
step of the way.

LIMITED WARRANTY - Subject to the terms and conditions below, Miller Electric Mfg. Co., Appleton, Wisconsin, warrants to its original retail purchaser that new Miller equipment sold after the effective date of this limited warranty is free of defects in material and workmanship at the time it is shipped by Miller. THIS WARRANTY IS EXPRESSLY IN LIEU OF ALL OTHER WARRANTIES, EXPRESS OR IMPLIED, INCLUDING THE WARRANTIES OF MERCHANTABILITY AND FITNESS.

Within the warranty periods listed below, Miller will repair or replace any warranted parts or components that fail due to such defects in material or workmanship. Miller must be notified in writing within thirty (30) days of such defect or failure, at which time Miller will provide instructions on the warranty claim procedures to be followed.

Miller shall honor warranty claims on warranted equipment listed below in the event of such a failure within the warranty time periods. All warranty time periods start on the date that the equipment was delivered to the original retail purchaser, or one year after the equipment is sent to a North American distributor or eighteen months after the equipment is sent to an International distributor.

- 5 Years Parts — 3 Years Labor
 - * Original main power rectifiers
 - * Inverters (input and output rectifiers only)
- 3 Years — Parts and Labor
 - * Transformer/Rectifier Power Sources
 - * Plasma Arc Cutting Power Sources
 - * Semi-Automatic and Automatic Wire Feeders
 - * Inverter Power Sources (Unless Otherwise Stated)
 - * Water Coolant Systems (Integrated)
 - * Intelligig
 - * Maxstar 150
 - * Engine Driven Welding Generators
(NOTE: Engines are warranted separately by the engine manufacturer.)
- 1 Year — Parts and Labor Unless Specified
 - * DS-2 Wire Feeder
 - * Motor Driven Guns (w/exception of Spoolmate Spoolguns)
 - * Process Controllers
 - * Positioners and Controllers
 - * Automatic Motion Devices
 - * RFCS Foot Controls
 - * Induction Heating Power Sources and Coolers
 - * Water Coolant Systems (Non-Integrated)
 - * Flowgauge and Flowmeter Regulators (No Labor)
 - * HF Units
 - * Grids
 - * Maxstar 85, 140
 - * Spot Welders
 - * Load Banks
 - * Arc Stud Power Sources & Arc Stud Guns
 - * Racks
 - * Running Gear/Trailers
 - * Plasma Cutting Torches (except APT & SAF Models)
 - * Field Options
(NOTE: Field options are covered under True Blue[®] for the remaining warranty period of the product they are installed in, or for a minimum of one year — whichever is greater.)
- 6 Months — Batteries
- 90 Days — Parts
 - * MIG Guns/TIG Torches

- * Induction Heating Coils and Blankets
- * APT & SAF Model Plasma Cutting Torches
- * Remote Controls
- * Accessory Kits
- * Replacement Parts (No labor)
- * Spoolmate Spoolguns
- * Canvas Covers

Miller's True Blue[®] Limited Warranty shall not apply to:

- Consumable components; such as contact tips, cutting nozzles, contactors, brushes, slip rings, relays or parts that fail due to normal wear. (Exception: brushes, slip rings, and relays are covered on Bobcat, Trailblazer, and Legend models.)**
- Items furnished by Miller, but manufactured by others, such as engines or trade accessories. These items are covered by the manufacturer's warranty, if any.
- Equipment that has been modified by any party other than Miller, or equipment that has been improperly installed, improperly operated or misused based upon industry standards, or equipment which has not had reasonable and necessary maintenance, or equipment which has been used for operation outside of the specifications for the equipment.

MILLER PRODUCTS ARE INTENDED FOR PURCHASE AND USE BY COMMERCIAL/INDUSTRIAL USERS AND PERSONS TRAINED AND EXPERIENCED IN THE USE AND MAINTENANCE OF WELDING EQUIPMENT.

In the event of a warranty claim covered by this warranty, the exclusive remedies shall be, at Miller's option: (1) repair; or (2) replacement; or, where authorized in writing by Miller in appropriate cases, (3) the reasonable cost of repair or replacement at an authorized Miller service station; or (4) payment of or credit for the purchase price (less reasonable depreciation based upon actual use) upon return of the goods at customer's risk and expense. Miller's option of repair or replacement will be F.O.B., Factory at Appleton, Wisconsin, or F.O.B. at a Miller authorized service facility as determined by Miller. Therefore no compensation or reimbursement for transportation costs of any kind will be allowed.

TO THE EXTENT PERMITTED BY LAW, THE REMEDIES PROVIDED HEREIN ARE THE SOLE AND EXCLUSIVE REMEDIES. IN NO EVENT SHALL MILLER BE LIABLE FOR DIRECT, INDIRECT, SPECIAL, INCIDENTAL OR CONSEQUENTIAL DAMAGES (INCLUDING LOSS OF PROFIT), WHETHER BASED ON CONTRACT, TORT OR ANY OTHER LEGAL THEORY.

ANY EXPRESS WARRANTY NOT PROVIDED HEREIN AND ANY IMPLIED WARRANTY, GUARANTY OR REPRESENTATION AS TO PERFORMANCE, AND ANY REMEDY FOR BREACH OF CONTRACT TORT OR ANY OTHER LEGAL THEORY WHICH, BUT FOR THIS PROVISION, MIGHT ARISE BY IMPLICATION, OPERATION OF LAW, CUSTOM OF TRADE OR COURSE OF DEALING, INCLUDING ANY IMPLIED WARRANTY OF MERCHANTABILITY OR FITNESS FOR PARTICULAR PURPOSE, WITH RESPECT TO ANY AND ALL EQUIPMENT FURNISHED BY MILLER IS EXCLUDED AND DISCLAIMED BY MILLER.

Some states in the U.S.A. do not allow limitations of how long an implied warranty lasts, or the exclusion of incidental, indirect, special or consequential damages, so the above limitation or exclusion may not apply to you. This warranty provides specific legal rights, and other rights may be available, but may vary from state to state.

In Canada, legislation in some provinces provides for certain additional warranties or remedies other than as stated herein, and to the extent that they may not be waived, the limitations and exclusions set out above may not apply. This Limited Warranty provides specific legal rights, and other rights may be available, but may vary from province to province.





Owner's Record

Please complete and retain with your personal records.

Model Name	Serial/Style Number
Purchase Date	(Date which equipment was delivered to original customer.)
Distributor	
Address	
City	
State	Zip



For Service

Contact a **DISTRIBUTOR** or **SERVICE AGENCY** near you.

Always provide Model Name and Serial/Style Number.

Contact your Distributor for:

- Welding Supplies and Consumables
 - Options and Accessories
 - Personal Safety Equipment
 - Service and Repair
 - Replacement Parts
 - Training (Schools, Videos, Books)
 - Technical Manuals (Servicing Information and Parts)
 - Circuit Diagrams
 - Welding Process Handbooks
- To locate a Distributor or Service Agency visit www.millerwelds.com or call 1-800-4-A-Miller

Contact the Delivering Carrier to:

- File a claim for loss or damage during shipment.
- For assistance in filing or settling claims, contact your distributor and/or equipment manufacturer's Transportation Department.

Miller Electric Mfg. Co.

An Illinois Tool Works Company
1635 West Spencer Street
Appleton, WI 54914 USA

International Headquarters—USA

USA Phone: 920-735-4505 Auto-Attended
USA & Canada FAX: 920-735-4134
International FAX: 920-735-4125

European Headquarters – United Kingdom

Phone: 44 (0) 1204-593493
FAX: 44 (0) 1204-598066

www.MillerWelds.com



Free Manuals Download Website

<http://myh66.com>

<http://usermanuals.us>

<http://www.somanuals.com>

<http://www.4manuals.cc>

<http://www.manual-lib.com>

<http://www.404manual.com>

<http://www.luxmanual.com>

<http://aubethermostatmanual.com>

Golf course search by state

<http://golfingnear.com>

Email search by domain

<http://emailbydomain.com>

Auto manuals search

<http://auto.somanuals.com>

TV manuals search

<http://tv.somanuals.com>