

FARBERWARE®

P R E F E R R E D



USE & CARE INSTRUCTIONS BELGIAN WAFFLE MAKER

FWM85B

IMPORTANT SAFEGUARDS

When using electrical appliances, basic safety precautions should always be followed, including the following:

1. Read all instructions
2. Do not touch hot surfaces. Use handles. Use oven mitts or potholders.
3. To protect against risk of electric shock, do not immerse cord, plugs, or appliance in water or other liquid.
4. Close supervision is necessary when any appliance is used by or near children.
5. Unplug from outlet when not in use and before cleaning. Allow to cool before putting on or taking off parts, and before cleaning the appliance.
6. Do not operate any appliance with a damaged cord or plug, or after the appliance malfunctions, or has been damaged in any manner. Contact Consumer Service for examination, repair or adjustment.
7. The use of accessory attachments not recommended by the appliance manufacturer may cause injuries.
8. Do not use outdoors.
9. Do not let cord hang over edge of table or counter, or touch hot surfaces.
10. Do not place on or near a hot gas or electric burner, or in a heated oven.
11. Extreme caution must be used when moving an appliance containing hot oil or other hot liquids.
12. To disconnect, slide Browning Control to LIGHT and then remove plug from wall outlet.
13. Do not use appliance for other than intended use.

**SAVE THESE INSTRUCTIONS
FOR HOUSEHOLD USE ONLY**

ADDITIONAL IMPORTANT SAFEGUARDS

CAUTION HOT SURFACES: This appliance generates heat and escaping steam during use. Proper precautions must be taken to prevent the risk of burns, fires or other damage to persons or property.

CAUTION: This appliance is hot during operation and retains heat for some time after removing plug from wall outlet. Always use oven mitts when handling hot materials and allow metal parts to cool before cleaning. Do not place anything on top of the Waffle Maker while it is operating or while it is hot.

1. All users of this appliance must read and understand this Owner's Manual before operating or cleaning this appliance.
2. The cord to this appliance should be plugged into a 120V AC electrical outlet only.
3. If this appliance begins to malfunction during use, immediately unplug the cord. Do not attempt to repair the malfunctioning appliance.
4. Do not leave this appliance unattended during use.

SHORT CORD INSTRUCTIONS

A short power-supply cord is provided to reduce the risk resulting from becoming entangled in or tripping over a longer cord.

Longer extension cords are available and may be used if care is exercised in their use.

If a longer extension cord is used, (1) the marked electrical rating of the extension cord should be at least as great as the electrical rating of the appliance, and (2) the longer cord should be arranged so that it will not drape over the counter top or table top where it can be pulled on by children or tripped over unintentionally.

ELECTRIC POWER

If the electrical circuit is overloaded with other appliances, your appliance may not operate properly. It should be operated on a separate electrical circuit from other appliances.

POLARIZED PLUG

This appliance has a polarized plug (one blade is wider than the other). To reduce the risk of electric shock, this plug is intended to fit into a polarized outlet only one way. If the plug does not fit fully in the outlet, reverse the plug. If it still does not fit, contact a qualified electrician. Do not attempt to modify the plug in any way.

GETTING TO KNOW YOUR FARBERWARE® FWM85B BELGIAN WAFFLE MAKER

PRODUCT MAY VARY SLIGHTLY FROM ILLUSTRATION.

**OPERATE ONLY IN THE
CLOSED POSITION.**

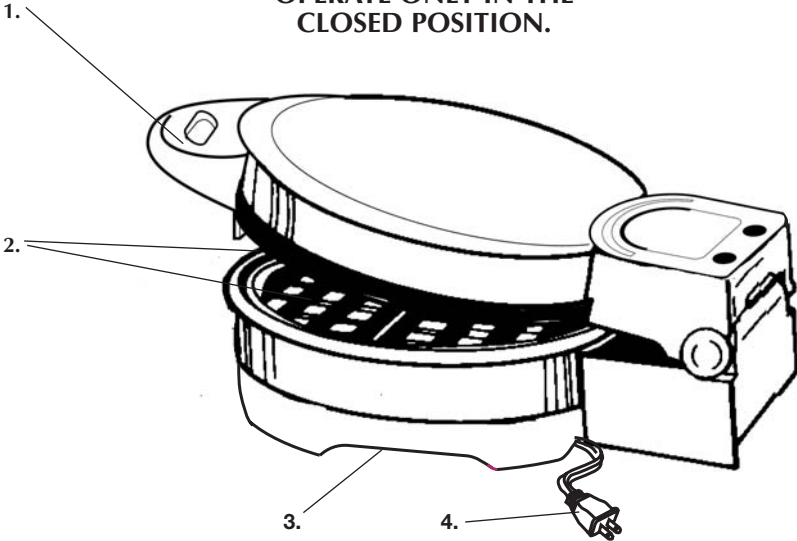

- 1. Handle
- 2. Non-Stick Cooking Plates
- 3. Cord Storage (on bottom)
- 4. Polarized Plug
- 5. Cook Light
- 6. Power ON Light
- 7. Browning Control
- 8. Body

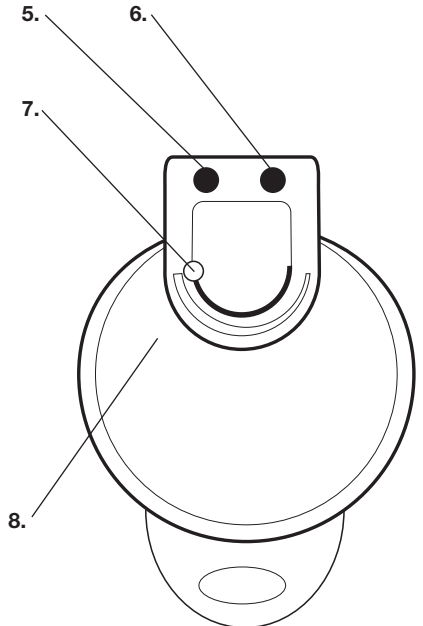

OPERATING INSTRUCTIONS

BEFORE USING FOR THE FIRST TIME

IMPORTANT: Before using for the first time, operate the appliance without batter in order to burn off residues on the Cooking Plates.

CAUTION: To avoid burns, caution should be taken when handling the Waffle Maker.

1. Carefully unpack Waffle Maker.
2. Wipe all surfaces with a slightly damp, soft cloth. Never immerse in water.
3. To burn off residues on the Cooking Plates, it will be necessary to operate the unit for a few minutes before initial use. **Do not add batter or oil during this time.**
4. Set the appliance on a dry, clean and flat countertop surface, where it can be easily plugged into an electrical outlet. Plug appliance into 120V AC electrical outlet.
5. You will notice smoke and a slight odor while residues burn off.
6. Allow the Waffle Maker to operate until smoke and odor dissipate; then unplug Waffle Maker and allow it to cool. **Be careful, the Cooking Plates will be hot!**

NOTE: Some odor may still be detected during initial use; this is normal and should disappear after one or two uses.

HOW TO USE YOUR WAFFLE MAKER

1. Be sure the Cooking Plates are clean and free from dust. If necessary, wipe with a damp cloth.
2. When using the Waffle Maker for the first time, brush the Cooking Plates with cooking oil.

NOTE: The Waffle Maker is coated with a non-stick surface. Do not use spray-on oils, grease or shortening, as they can cause build-up on the Cooking Plates. Use cooking oil instead.

3. Close the Lid.
4. Plug appliance into a suitable 120V AC electrical outlet; the Power ON Light and the Cook Light will illuminate, indicating the unit has begun heating.
5. Slide the Browning Control to set desired browning: for LIGHT, MEDIUM or DARK waffles.
6. While preparing batter, allow appliance to pre-heat (about 5 minutes). The Cook Light will go off when unit has reached the proper temperature.
7. Open Waffle Maker and carefully pour batter evenly to cover the Cooking Plates. Be careful not to pour too much batter, as excess batter will seep out of Cooking Plates.

OPERATING INSTRUCTIONS (CONTINUED)

8. Carefully close the Waffle Maker. Do not force shut. Steam will be released between the Cooking Plates. Caution should be taken to prevent hands from coming into contact with the steam.

9. Your FARBERWARE® FWM85B has a Browning Control. When preparing a recipe for the first time, it may become necessary to experiment with the Browning Control. Begin by setting the Control to halfway between LIGHT and DARK. After the first waffle, move the Browning Control up or back to the desired brownness color setting. Browning may differ depending on the batter ingredients. Batters using sugar tend to brown quicker.

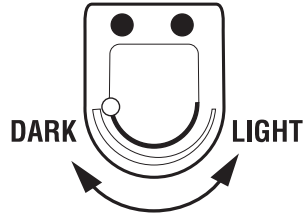

10. Cooking time should take approximately 3-5 minutes. Exact cooking time will be a matter of your taste and will depend on type of batter and ingredients used. The Cook Light turns on and off as the unit cycles to maintain ideal heating temperatures; this prevents overheating. Avoid opening your Waffle Maker before cooking is completed, as this may cause the waffle to stick or bake poorly.
11. When the waffles are cooked, remove them by using a plastic or wooden spatula. Do not use metal tongs or knives, as these may damage the non stick coating.
12. Keep the Waffle Maker closed to preserve the heat until ready for the next batch of waffles.
13. After use, slide Browning Control to LIGHT and then immediately unplug from the electrical outlet.
14. If waffles are not to be consumed immediately, place the waffles on a paper napkin to absorb condensation. To keep hot, place on a rack in an ovenproof dish and warm in the oven at about 200°-250°F. Waffles will keep for about 20 minutes and then begin to dry out.

USER MAINTENANCE INSTRUCTIONS

This appliance requires little maintenance. It contains no user serviceable parts. Do not try to repair it yourself. Any servicing requiring disassembly other than cleaning must be performed by a qualified appliance repair technician.

TO CLEAN

CAUTION: Do not immerse the Waffle Maker, cord, or plug in water or any other liquid.

Unplug and allow to cool before cleaning. Do not use steel wool, scouring pads or abrasive cleaners, as this will damage the finish.

INSIDE CLEANING

Wipe Cooking Plates with absorbent paper toweling or a soft cloth. Although the Cooking Plates are coated with a non-stick coating, some batter or ingredients may still adhere to the Waffle Maker. To remove, simply pour a little cooking oil onto the baked-on food. Allow to stand for 5 to 10 minutes. This should soften the food and make it easy to remove with absorbent paper toweling or a soft cloth. If the preceding measure fails to remove the food residue, we suggest wiping the Cooking Plates with a slightly dampened cloth and a little non-abrasive detergent.

OUTSIDE CLEANING

Wipe with a soft, dry cloth.

TO STORE

Unplug unit and allow to cool.

Store in its box or in a clean, dry place.

Never store Waffle Maker while it is hot or still plugged in.

Use the Cord Storage Wrap located on the bottom of the Waffle Maker.

Never wrap cord tightly around the appliance. Do not put any stress on cord where it enters unit, as this could cause cord to fray and break.

The Waffle Maker can be placed in a vertical position (handles pointed up) for neat and compact storage.

HELPFUL HINTS

- Sift all dry ingredients.
- Egg yolks should be separated from egg whites before mixing.
- Beating egg whites separately, and then folding into the batter, will create lighter and crispier waffles.
- Egg whites should be beaten until they form stiff peaks. Stir 1/4 of beaten egg whites into batter to lighten it, then gently fold the rest of the egg whites into the batter (there should be white streaks in the batter). Do not over-mix batter when adding egg whites.
- It is not necessary to beat egg yolks and milk separately; just add to the combined flour mixture, and use a whisk or hand mixer to blend.
- Do not open the Waffle Maker during the first minute of baking, or waffles will separate. Completely bake waffles before removing them from the unit.
- When waffles are done, the Lid should lift open easily. Lift the Lid gently. If Lid pulls, wait another minute and try lifting it open again.
- Adjust the Browning Control as you prepare your waffles. Remember that different recipes may produce varying browning results depending on the ingredients. It may become necessary to turn the Browning Control down slightly when baking waffles containing sugar.
- Waffles can be made ahead of time, then refrigerated or frozen. When ready to eat, just heat waffles in oven or toaster. This is ideal when serving waffles to several people at once.

FOR LOW-FAT, LOW-CHOLESTEROL WAFFLES

- All recipes work equally well with skim milk.
- Leave out egg yolks altogether. All leavening properties come from the beaten egg whites.
- Use liquid vegetable oils, like canola, corn or sunflower, instead of butter.

FOR HIGHER-FIBER WAFFLES

- Substitute 1/2-cup, or more, of whole wheat flour for white flour.
- Substitute 1/4-cup of wheat, or oat bran, for white flour.

FOR SUGARLESS WAFFLES

- Substitute 1 tablespoon of thawed all-natural white grape or apple juice, from concentrate, for each teaspoon of sugar. If adding more than 1 tablespoon of juice from concentrate, add a little less milk.

RECIPES

BASIC WAFFLES

1 cup all-purpose flour	1 teaspoon sugar
1 teaspoon baking powder	1 cup milk
1/2 teaspoon salt	1 egg, separated
1/2 teaspoon butter, melted	

Sift dry ingredients together in a bowl.

Add egg yolk and milk to the dry ingredients and beat together thoroughly.

Pour a scant 1/2 cup of batter onto the heated waffle mold.

Makes about 6 waffles.

TRADITIONAL WAFFLES

1/2 cup butter, melted	1 cup milk
3/4 cup sugar	3 eggs, separated
2-1/4 cups flour	Pinch of salt
1 teaspoon baking powder	Twist of lemon

Sift dry ingredients together in a bowl.

Add egg yolks and milk to dry ingredients and beat together thoroughly.

In a separate bowl, beat egg whites until stiff. Stir 1/2 of the egg whites into the batter, and then fold in the remaining egg whites and stir until well blended.

Add butter and twist of lemon, and mix until smooth.

Pour scant 1/3 cup of batter on the heated waffle mold.

Makes about 12-18 waffles.

BELGIAN WAFFLES

2-2/3 cups all-purpose flour	2 tablespoons sugar
2-1/4 tsp. RED STAR® active dry yeast	1 teaspoon salt
1-3/4 cups milk	1/4 cup water
1/4 cup butter	3 eggs

Sift dry ingredients together in a bowl.

In a microwave or double boiler, heat milk, water and butter until very warm, 120°-130°F (butter does not need to melt).

Add milk mixture and eggs to dry ingredients. Using a hand mixer, mix together thoroughly.

Cover bowl with plastic wrap or foil and refrigerate several hours or overnight.

Pour 1 cup of batter onto the preheated, conditioned Waffle Plates.

Makes 16 individual waffles.

WHOLE WHEAT BANANA NUT WAFFLES

1/2 cup whole wheat flour	1/4 teaspoon salt
1/2 cup all-purpose flour	3/4 cup milk
1 teaspoon baking powder	1 banana
1 teaspoon melted butter or vegetable oil	1 egg, separated
1/2 cup walnuts, minced	

Sift dry ingredients together in a bowl.

Add egg yolk and milk to the dry ingredients and beat together thoroughly.

Mash banana and beat banana and nuts into batter.

Beat egg white until stiff, stir 1/4 into the batter to lighten it, and then gently fold in the remaining white.

Pour scant 1/3 cup of batter on the heated waffle mold.

Makes 6 waffles.

Serve with applesauce or yogurt.

SHORTBREAD WAFFLES

1 cup butter	4 eggs
1 cup sugar	Twist of lemon
1-3/4 cup flour	

Sift flour and sugar together in a bowl.

In a separate bowl, beat eggs until fluffy.

Add eggs to flour and sugar mix, and beat together thoroughly.

Add butter and twist of lemon, and mix until smooth.

Pour scant 1/3 cup of batter on the heated waffle mold.

Makes about 12-18 waffles.

YEAST WAFFLES

1 (1/4-oz.) package dry yeast	3-1/4 cups flour
1/2 cup butter	6 eggs
1/4 cup sugar	Twist of lemon
1 cup milk	Pinch of salt

Sift dry ingredients together in a bowl.

In a separate bowl, beat eggs until fluffy.

Mix milk and eggs, and then add to dry ingredients; beat together until well blended.

Add butter and twist of lemon, and mix until smooth.

Pour scant 1/3 cup of batter on the heated waffle mold.

Makes about 12-18 waffles.

CHOCOLATE WAFFLES

1 cup all-purpose flour	2/3 cup milk
1 teaspoon baking powder	1 egg, separated
1/4 teaspoon salt	2 teaspoon melted butter
2 teaspoon sugar	3/4 teaspoon vanilla
1-1/2 squares semi-sweet chocolate (1-1/2 ounces)	

Sift dry ingredients together in a bowl.

Add milk, egg yolk and vanilla to dry ingredients and beat until well blended.

Melt butter and chocolate together in microwave or double boiler. Stir chocolate mixture into batter.

Beat egg white until stiff, stir 1/4 into the batter to lighten, and then gently fold in the remaining egg white.

Pour a scant 1/2 cup of batter onto the heated waffle mold.

Makes about 6 waffles. Serve sprinkled with powdered sugar or cinnamon or topped with vanilla ice cream and chocolate sauce.

Chocolate waffles make great ice cream sandwiches!

Freeze them first. Spread with any flavor ice cream, add nuts or raisins, and top with a second waffle.

PEANUT BUTTER WAFFLES

1 cup all-purpose flour	1/4 cup peanut butter
2 teaspoon baking powder	1 cup milk
1/2 teaspoon salt	1 egg, separated
2 teaspoon sugar	1/2 teaspoon vanilla
1/2 teaspoon melted butter or vegetable oil	

Sift dry ingredients together in a bowl.

Process peanut butter, egg yolk, milk, vanilla and butter together in a blender. Add milk mixture to dry ingredients and beat until well blended.

Pour a scant 1/2 cup of batter onto the heated waffle mold.

Makes about 6 waffles.

FARBERWARE®

ONE-YEAR LIMITED WARRANTY

Warranty: This Farberware® product is warranted by Salton, Inc. to be free from defects in materials or workmanship for a period of (1) year from the original purchase date. This product warranty covers only the original consumer purchaser of the product.

Warranty Coverage: This warranty is void if the product has been damaged by accident in shipment, unreasonable use, misuse, neglect, improper service, commercial use, repairs by unauthorized personnel, normal wear and tear, improper assembly, installation or maintenance abuse or other causes not arising out of defects in materials or workmanship. This warranty is effective only if the product is purchased and operated in the USA, and does not extend to any units which have been used in violation of written instructions furnished with the product or to units which have been altered or modified or to damage to products or parts thereof which have had the serial number removed, altered, defaced or rendered illegible.

Implied Warranties: ANY IMPLIED WARRANTIES WHICH THE PURCHASER MAY HAVE ARE LIMITED IN DURATION TO ONE (1) YEAR FROM THE DATE OF PURCHASE. Some states do not allow limitations on how long an implied warranty lasts, so the above limitation may not apply to you.

Warranty Performance: During the above one-year warranty period, a product with a defect will be either repaired or replaced with a reconditioned comparable model (at our option) when the product is returned to the Repair Center, or the purchase price refunded. The repaired or replacement product will be in warranty for the balance of the one-year warranty period and an additional one-month period. No charge will be made for such repair or replacement.

Service and Repair: Should the appliance malfunction, you should first call toll-free 1 (888) 881-8101 between the hours of 9:00 am and 5:00 pm Central Standard Time and ask for CONSUMER SERVICE stating that you are a consumer with a problem. Please refer to model number FWM85B when you call.

In-Warranty Service (USA): For an appliance covered under the warranty period, no charge is made for service or postage. Call for return authorization 1 (888) 881-8101.

Out-of-Warranty Service: A flat rate charge by model is made for out-of-warranty service. Include \$8.00 (U.S.) for return shipping and handling. We will notify you by mail of the amount of the charge for service and require you to pay in advance for the repair or replacement.

For Products Purchased in the USA, but Used in Canada: You may return the product insured, packaged with sufficient protection, and postage and insurance prepaid to the USA address listed below. Please note that all customs duty / brokerage fees, if any, must be paid by you and we will require you to pay the cost of customs duty / brokerage fees to us in advance of our performing any service.

Risk During Shipment: We cannot assume responsibility for loss or damage during incoming shipment. For your protection, carefully package the product for shipment and insure it with the carrier. Be sure to enclose the following items with your appliance: any accessories related to your problem, your full return address and daytime phone number, a note describing the problem you experienced, a copy of your sales receipt or other proof of purchase to determine warranty status. C.O.D. shipments cannot be accepted.

To return the appliance, ship to:

ATTN: Repair Center
Salton, Inc.
708 South Missouri Street
Macon, MO 63552

To contact us, please write to, call, or email:

Salton, Inc.
P.O. Box 7366
Columbia, MO 65205-7366
1-888-881-8101
E-mail: Farberware-electric@Saltonusa.com

Limitation of Remedies: No representative or person is authorized to assume for Salton, Inc. any other liability in connection with the sale of our products. There shall be no claims for defects or failure of performance or product failure under any theory of tort, contract or commercial law including, but not limited to negligence, gross negligence, strict liability, breach of warranty and breach of contract. Repair, replacement or refund shall be the sole remedy of the purchaser under this warranty, and **in no event shall Salton be liable for any incidental or consequential damages, losses or expenses.** Some states do not allow the exclusion or limitation of incidental or consequential damages, so the above limitation or exclusion may not apply to you.

Legal Rights: This warranty gives you specific legal rights, and you may also have other rights which vary from state to state.

For more information on Salton products, visit our website: www.eSalton.com

©2003 Salton, Inc. All rights reserved.

FARBERWARE® is a registered trademark of Farberware Inc.®

Manufactured and sold pursuant to a license from Farberware Inc.®

02/03 PRINTED IN CHINA

P/N 61267

Free Manuals Download Website

<http://myh66.com>

<http://usermanuals.us>

<http://www.somanuals.com>

<http://www.4manuals.cc>

<http://www.manual-lib.com>

<http://www.404manual.com>

<http://www.luxmanual.com>

<http://aubethermostatmanual.com>

Golf course search by state

<http://golfingnear.com>

Email search by domain

<http://emailbydomain.com>

Auto manuals search

<http://auto.somanuals.com>

TV manuals search

<http://tv.somanuals.com>