

**W** Walker  
Edison  
furniture company

Item #: WQ42BC1  
Assembly Instructions

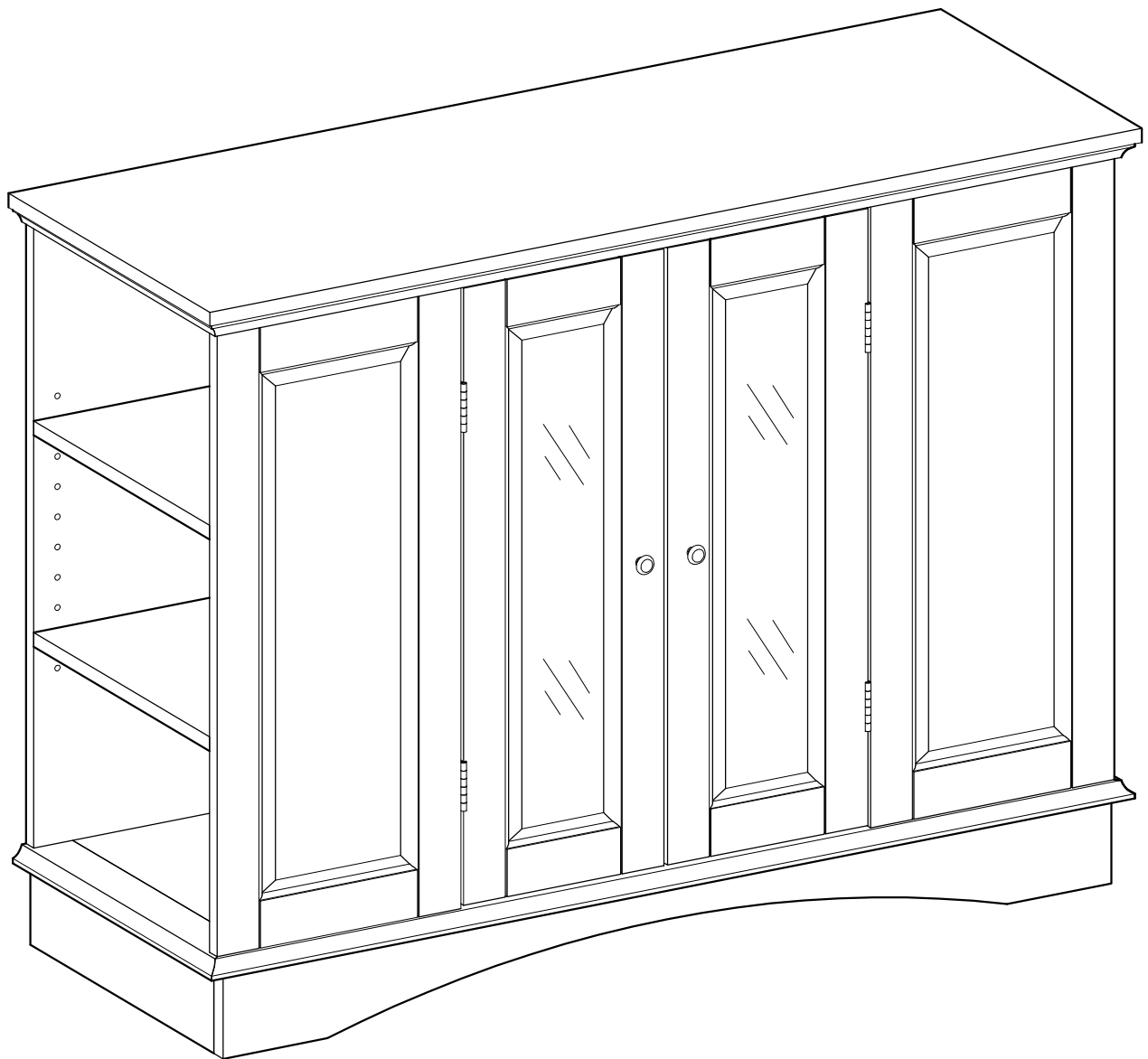

*For our most current instructions, to request missing, lost or broken parts, or for any other Customer Service issues, please visit our website at [www.walker-edison.com](http://www.walker-edison.com) or call us at 877-207-5906.*

Revised 09/2010

# General Assembly Guidelines

- I. Ensure that all parts and hardware are available before beginning assembly.
- II. Follow each step carefully to ensure the proper assembly of this product.
- III. Two people are recommended for ease in the assembly of this product.
- IV. The four main types of hardware used to assemble this product are: wood dowels, cam bolts and locks, bolts and screws.
- V. The provided glue is to secure wood dowels in place. When first inserting dowels, locate the appropriate hole for the dowel, place a small amount of glue in the hole and insert the dowel. Wipe away excess glue immediately.

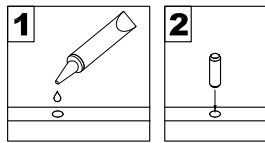

In future assembly steps when dowels are necessary to attach assembly parts together, place a small amount of glue on the end of the dowel before attaching parts together. Wipe away excess glue immediately.

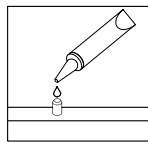

- VI. A Phillips head screwdriver is required for the assembly of this product.





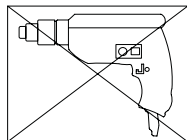



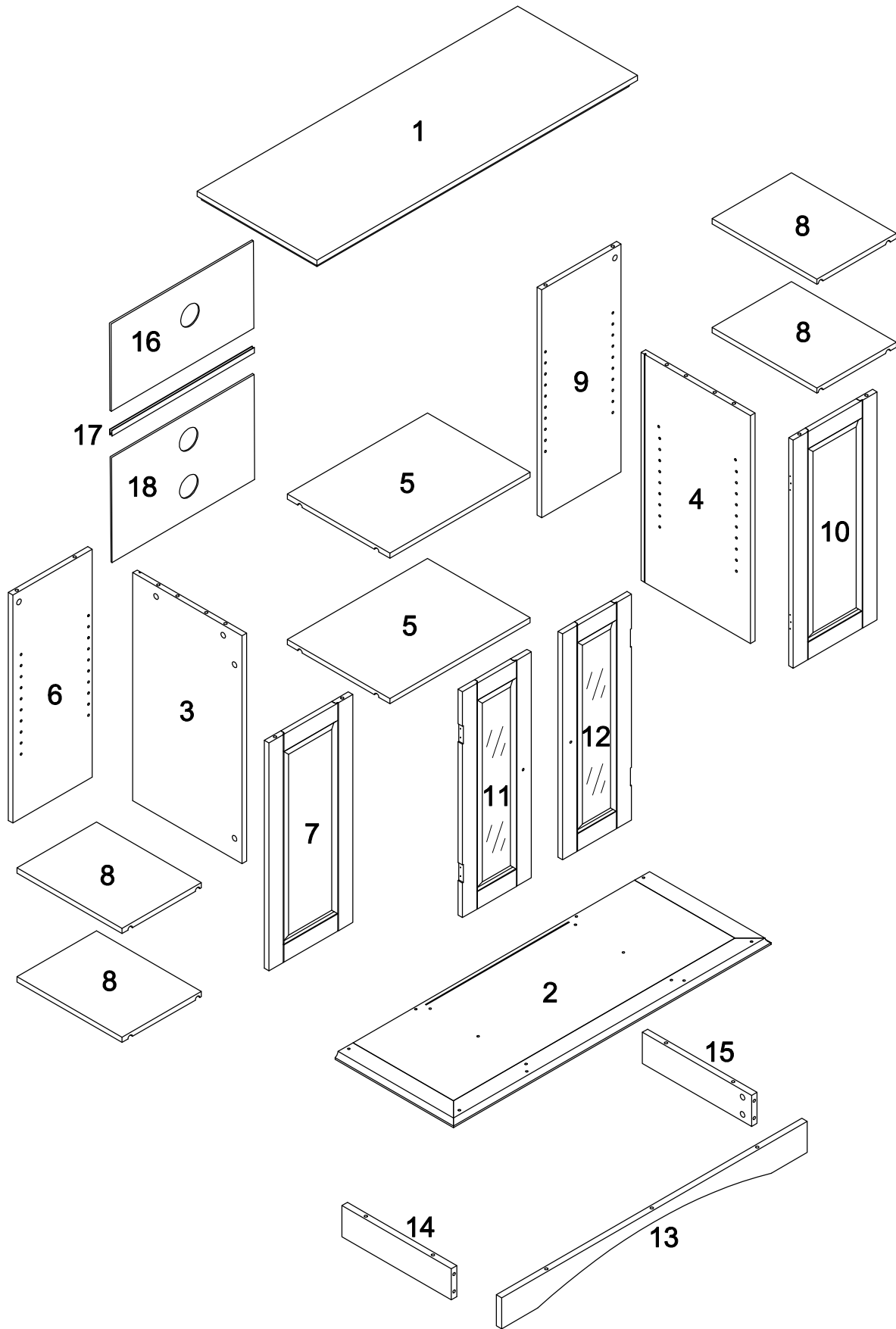





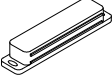

- VII. Power tools should not be used to assemble this product.

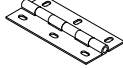
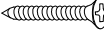

# Parts List



## Hardware List

A		Ø8x30mm	Wood dowel	19 pcs
B		Ø6x35mm	Cam bolt	16 pcs
C		Ø15x12mm	Cam lock	16 pcs
D			Door stopper	1 pc
E		Ø3x15mm	Round-headed screw	2 pcs
F		Ø6x50mm	Large bolt	14 pcs
G		Ø30x10x1mm	Door stopper plate	2 pcs
H		Ø3x12mm	Small screw	2 pcs
I		Ø83x23x2mm	Door hinge	4 pcs
J		Ø3x15mm	Medium screw	24 pcs
K		Ø25x17mm	Handle	2 pcs
L		Ø4x19mm	Small bolt	2 pcs
M		Ø5x15mm	Shelf support pin	24 pcs
N			Plastic wedge	8 pcs
P		Ø3x17mm	Large screw	8 pcs
Q		Ø4	Wrench	1 pc
R			Glue tube	3 pcs
S		Ø25	Sticker	32 pcs

*The hardware quantities listed above are required for proper assembly.  
Some extra hardware may also have been included.*

# Step 1

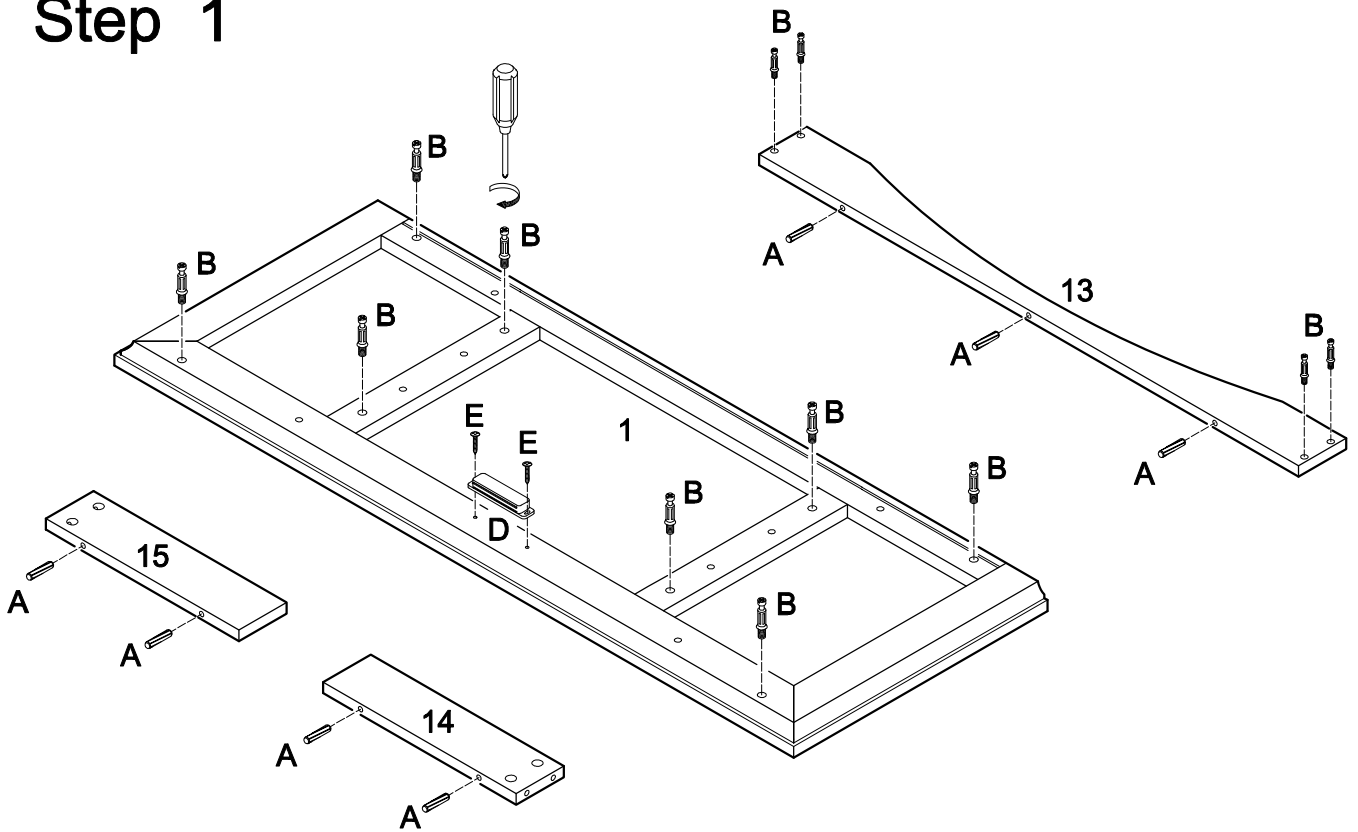

Insert dowels (A) into slats (13,14,15). Screw cam bolts (B) into top panel (1) and slat (13). Attach door stopper (D) to top panel (1) using round-headed screws (E).

# Step 2

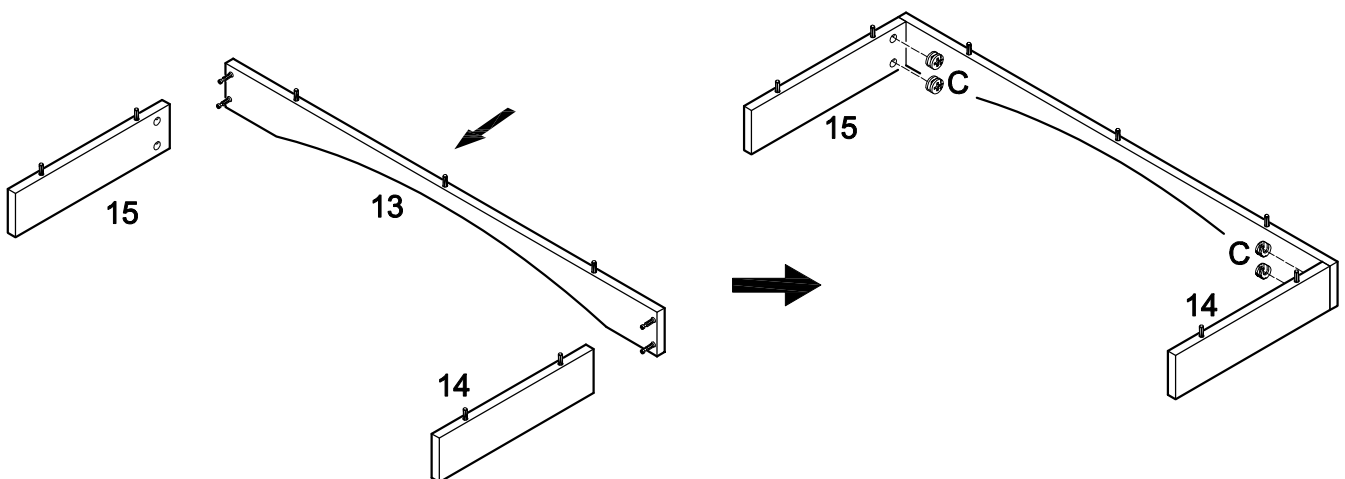
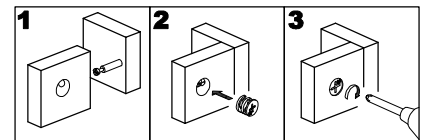

Attach slats (14,15) to slat (13) using cam bolts as guides. Insert cam locks (C) into slats (14,15) and tighten with a screwdriver.

## Step 3

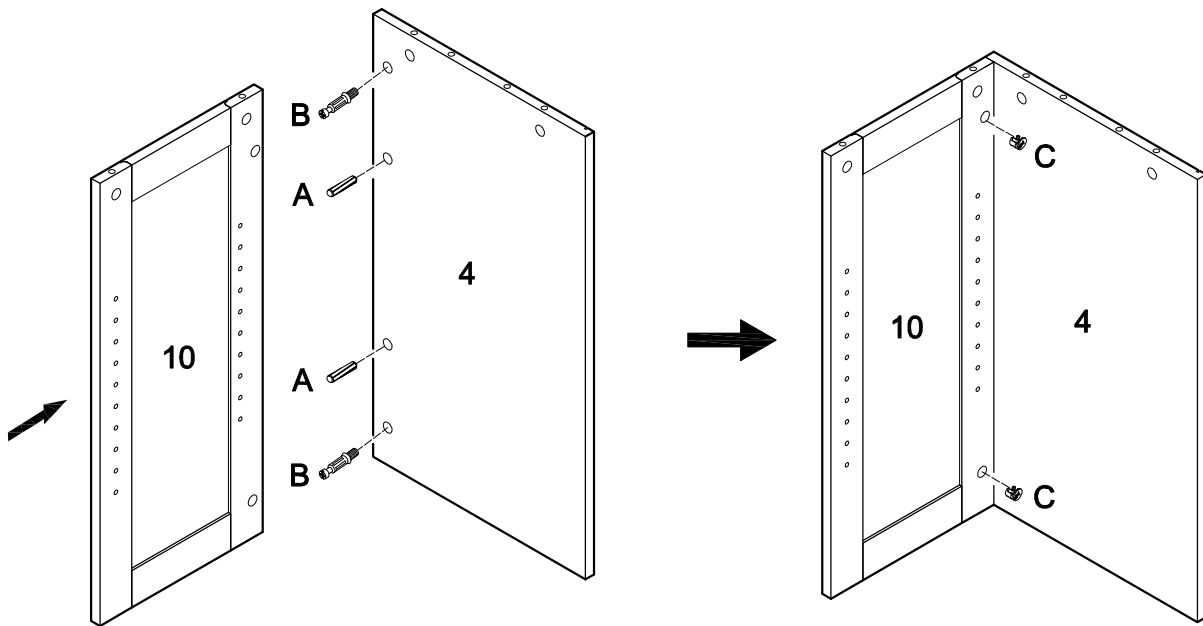
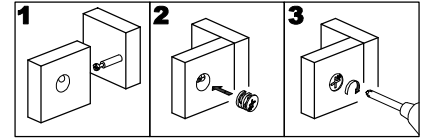

Screw cam bolts (B), and insert dowels (A) into panel (4). Attach panel (10) to panel (4) using cam bolts and dowels as guides. Insert cam locks (C) into panel (10) and tighten with a screwdriver.

## Step 4

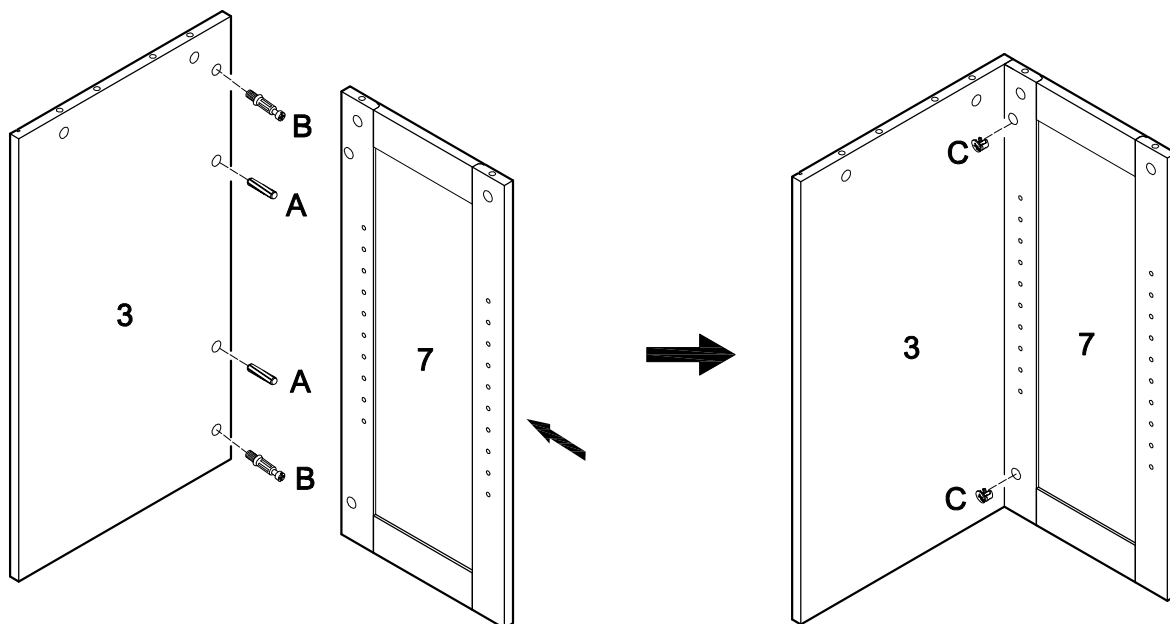
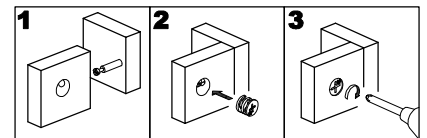

Screw cam bolts (B), and insert dowels (A) into panel (3). Attach panel (7) to panel (3) using cam bolts and dowels as guides. Insert cam locks (C) into panel (7) and tighten with a screwdriver.

## Step 5

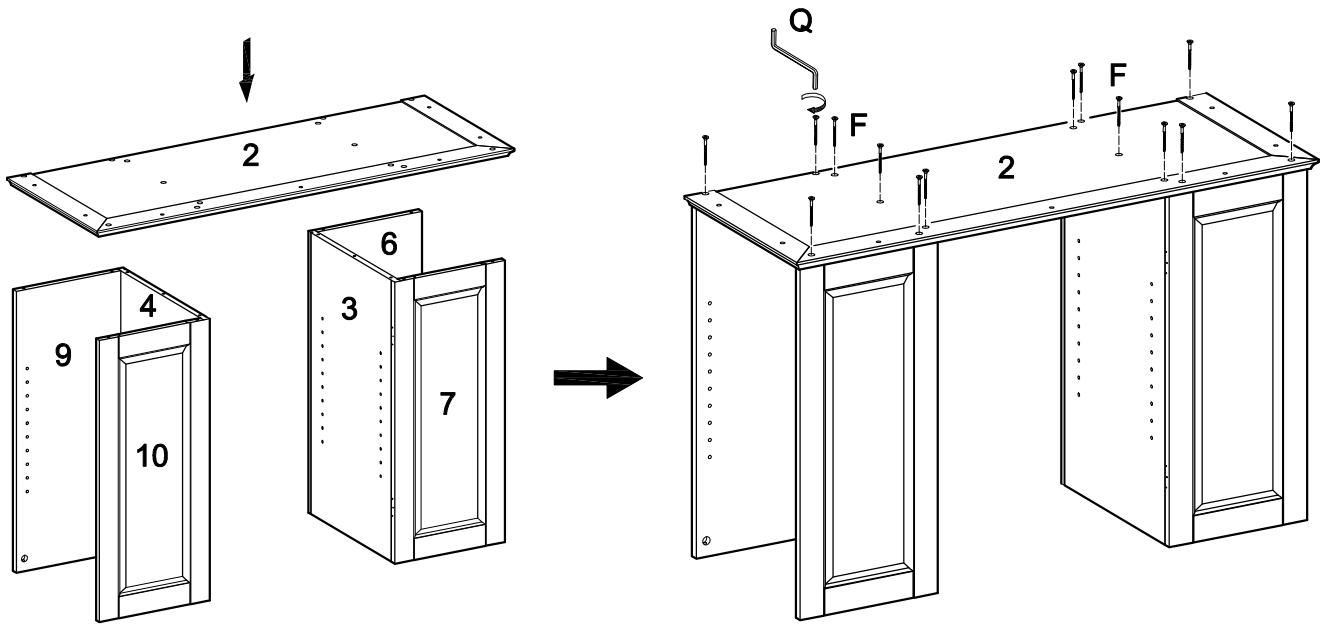

Attach bottom panel (2) to the panel assemblies from Steps 3 and 4, and to panels (6,9) using large bolts (F) and wrench (Q). *Note that panels (6,9) will not be directly attached to the panel assemblies from Steps 3 and 4.*

## Step 6

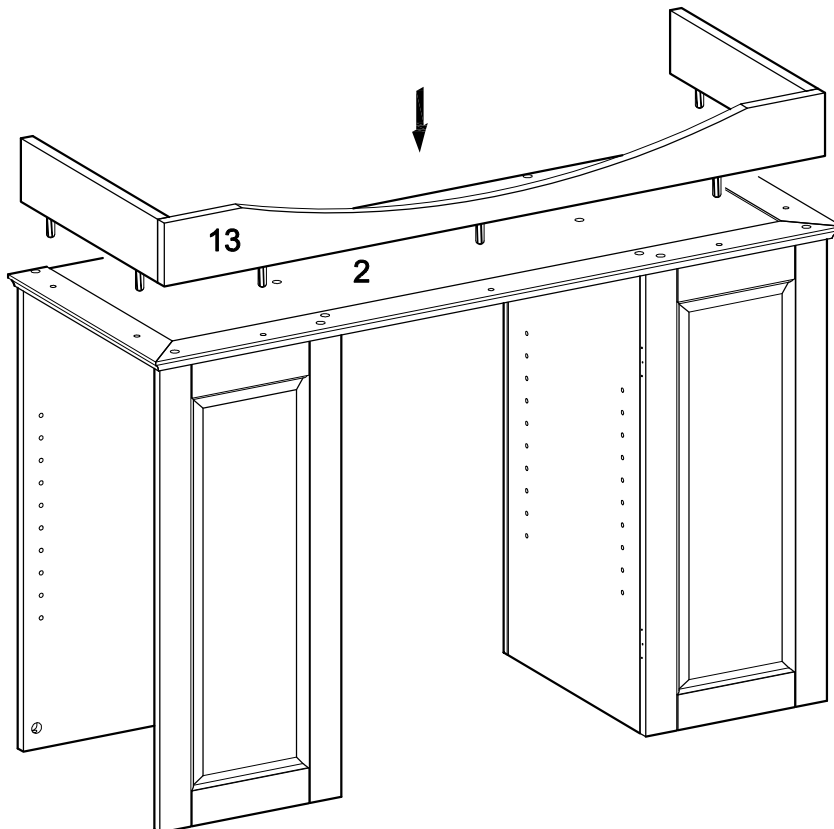

Attach the base assembly from Step 2 to bottom panel (2) by inserting the dowels of the base assembly into the pre-drilled holes of bottom panel (2).

## Step 7

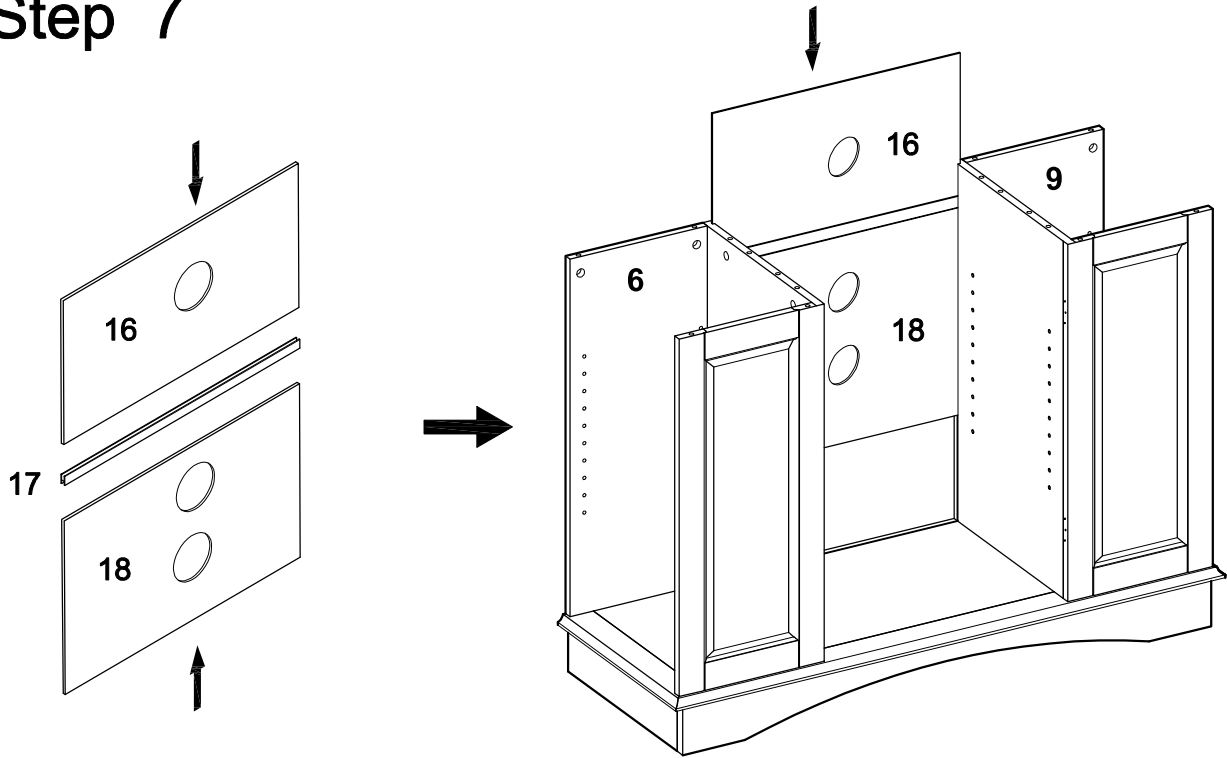

Slide back panel (18), back slat (17) then back panel (16) into the stand assembly.

## Step 8

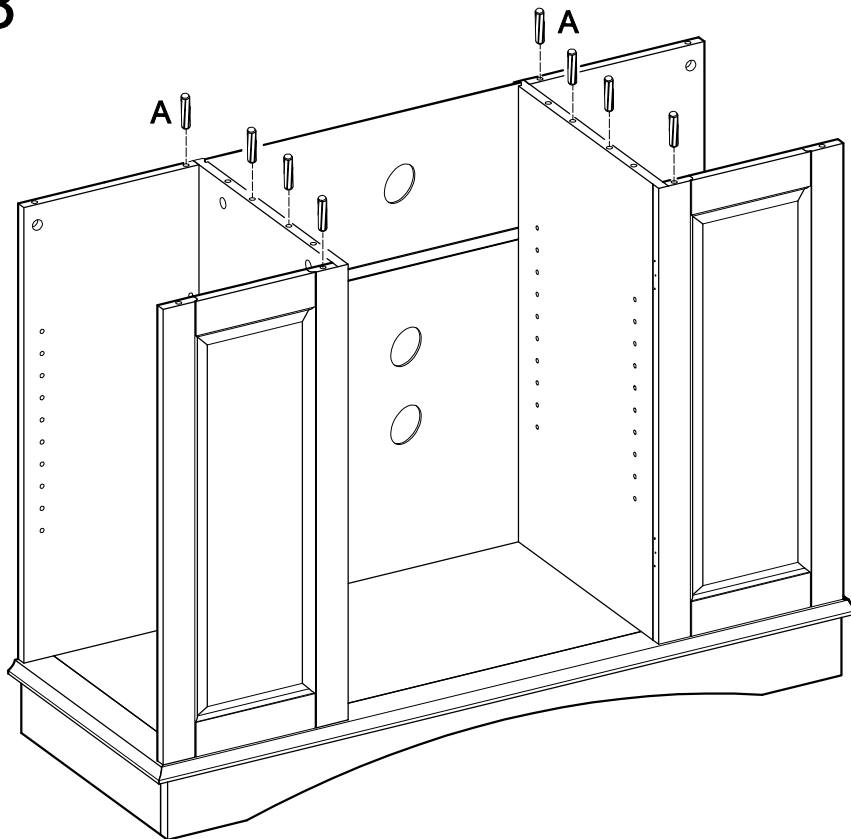

Insert dowels (A) into the stand assembly.



## Step 9

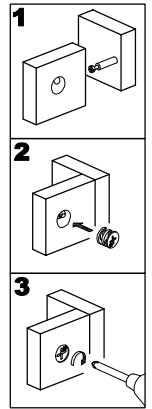
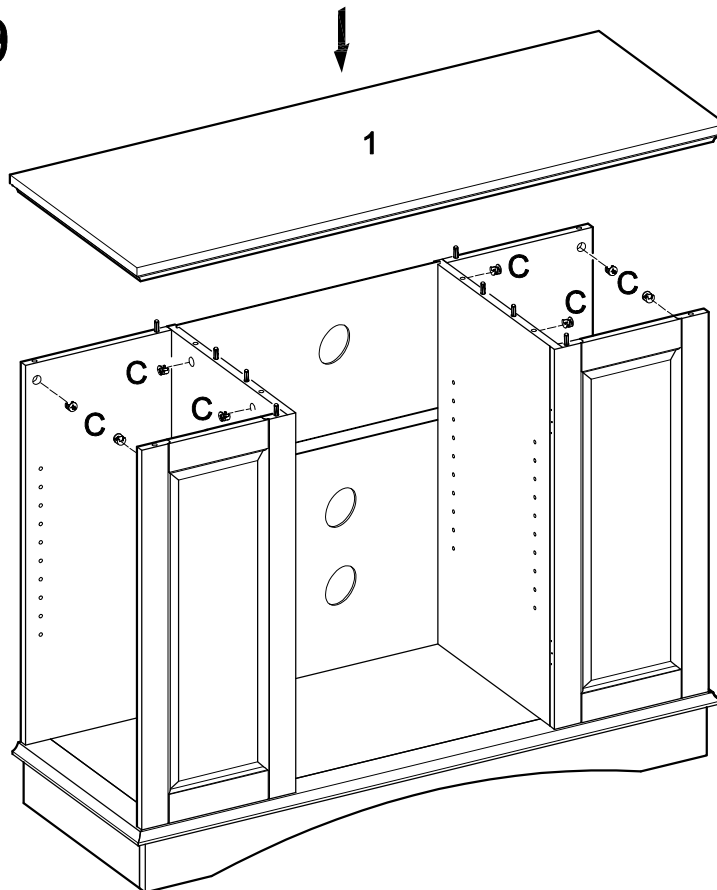

Insert cam locks (C) into the stand assembly. Attach top panel (1) to the stand assembly using cam bolts and dowels as guides. Tighten cam locks (C) with a screwdriver to secure top panel (1).

## Step 10

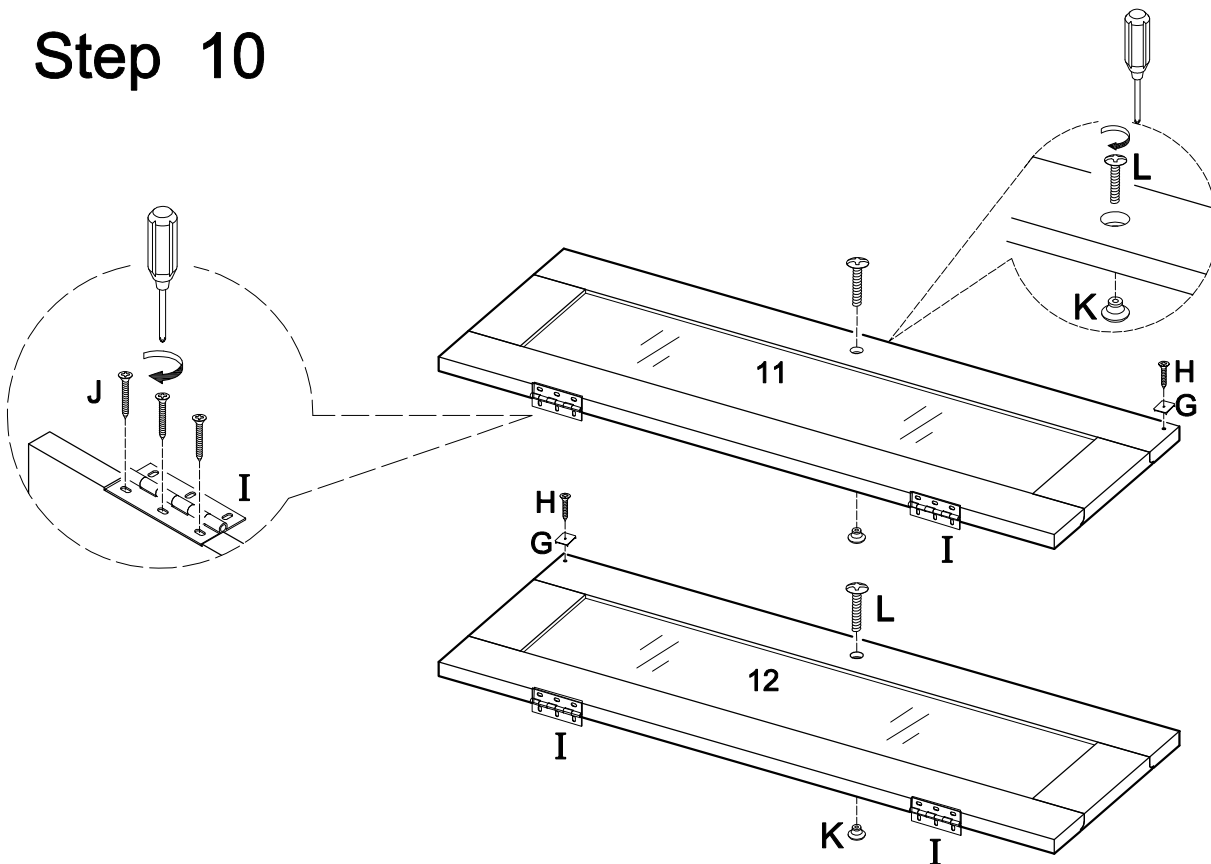

Attach door hinges (I) to doors (11,12) using medium screws (J). Attach handles (K) to doors (11,12) using small bolts (L). Attach door stopper plates (G) to doors (11,12) using small screws (H).

## Step 11

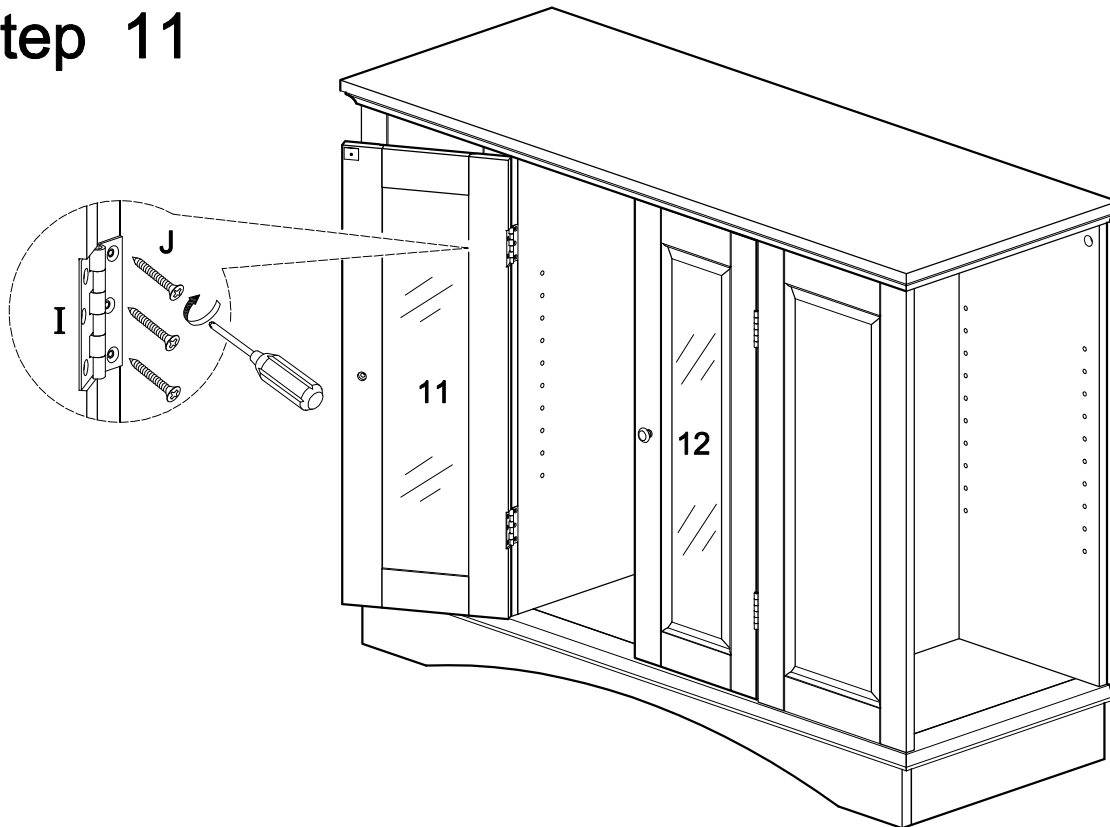

Attach doors (11,12) to the stand assembly at hinges (I) using medium screws (J). For proper alignment of doors, it may be necessary to loosen small screws (J), adjust the placement of hinges (I) and re-tighten screws (J).

## Step 12

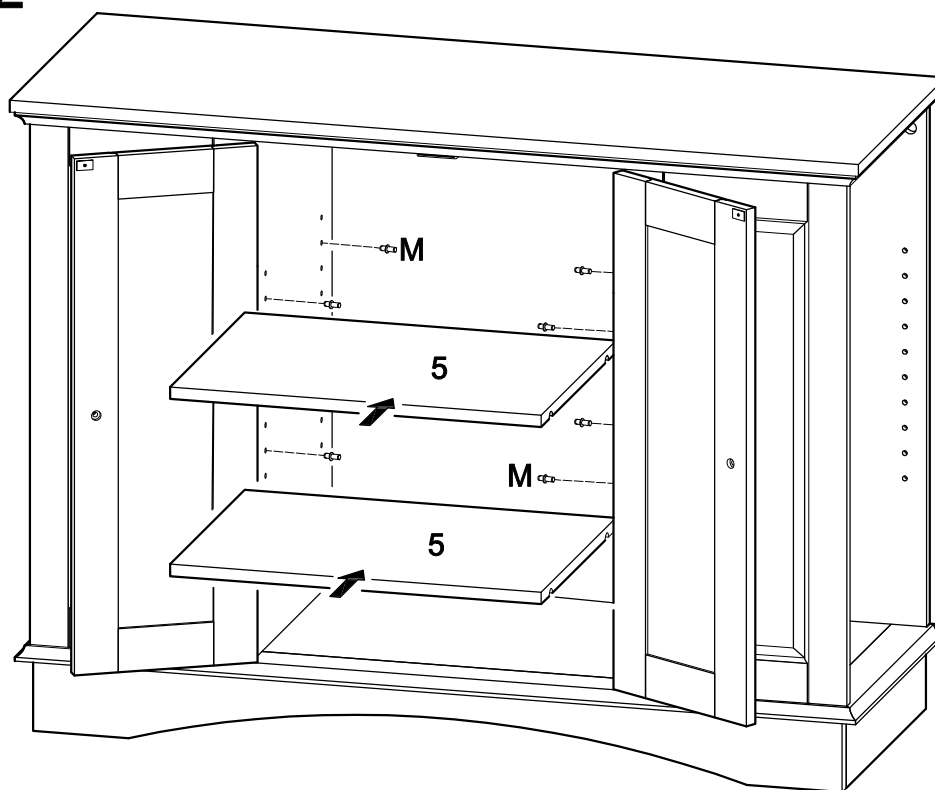

Insert shelf support pins (M) into the stand at desired shelf heights. Carefully place shelves (5) onto shelf support pins (M). Note that there will be two shelf support pins (M) on either end of each shelf (5).

## Step 13

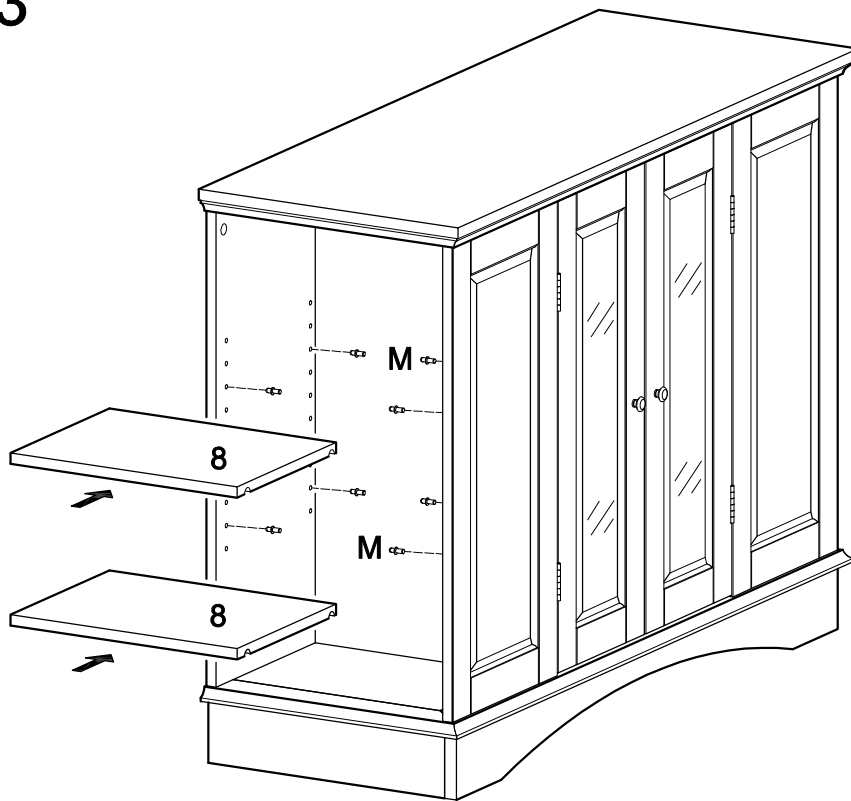

Insert shelf support pins (M) into the stand at desired shelf heights. Carefully place shelves (8) onto shelf support pins (M). *Note that there will be two shelf support pins (M) on either end of each shelf (8).*

## Step 14

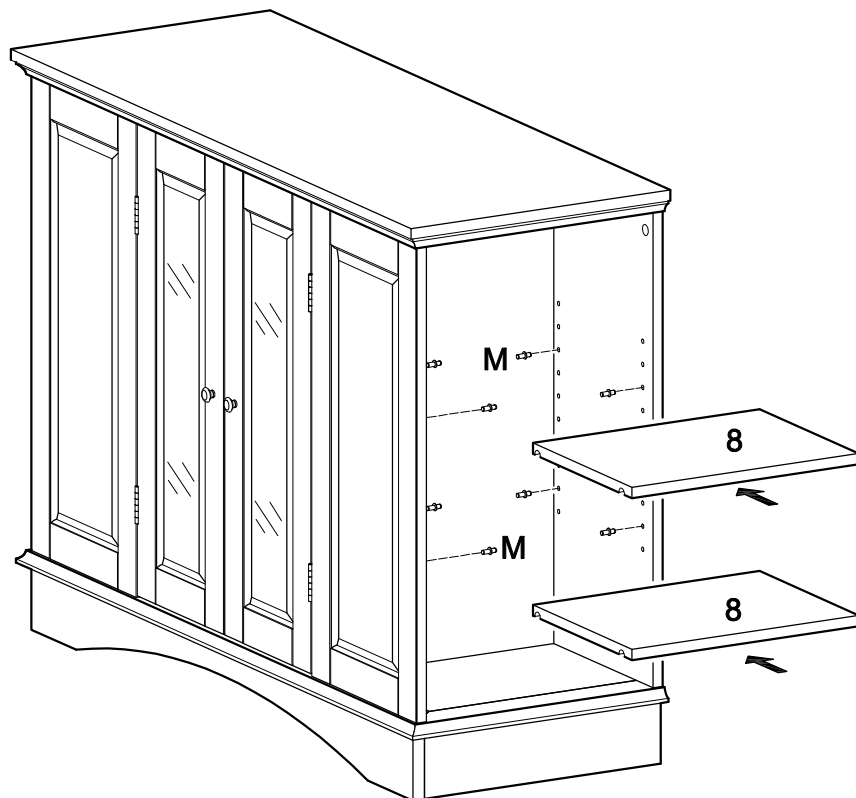

Insert shelf support pins (M) into the stand at desired shelf heights. Carefully place shelves (8) onto shelf support pins (M). *Note that there will be two shelf support pins (M) on either end of each shelf (8).*

## Step 15

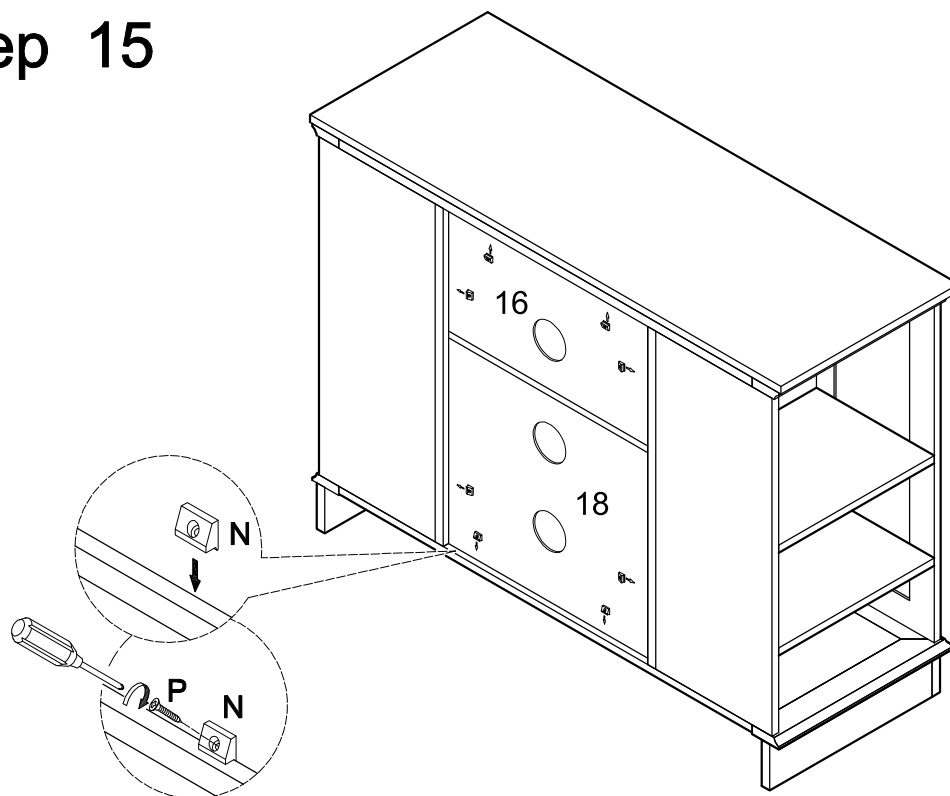

Secure back panels (16,18) using plastic wedges (N) and large screws (P).

## Step 16

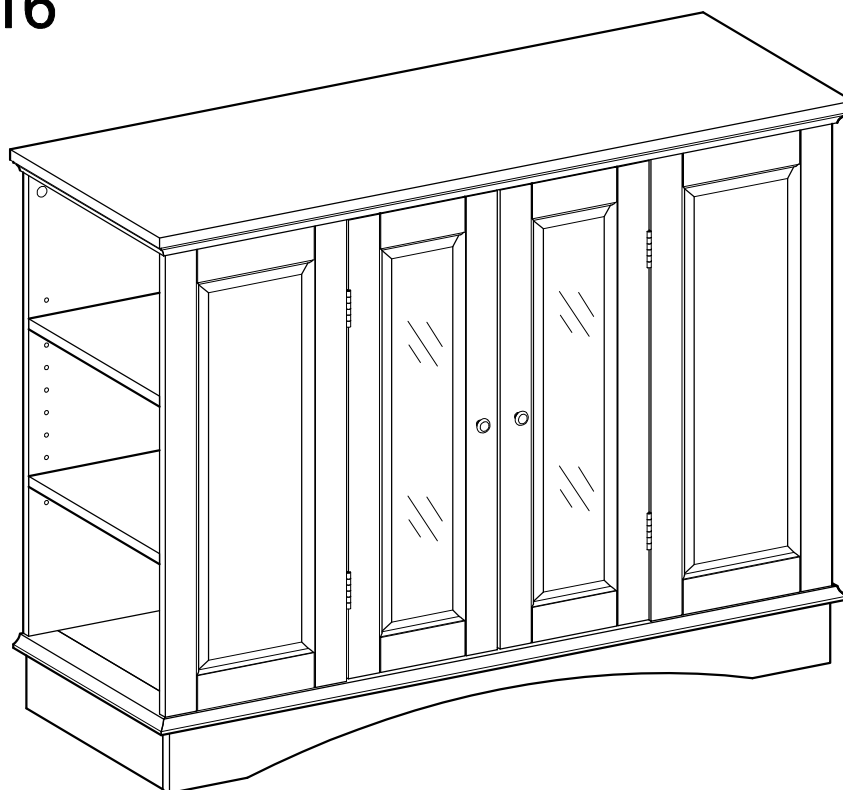

### Final Assembly

## Free Manuals Download Website

<http://myh66.com>

<http://usermanuals.us>

<http://www.somanuals.com>

<http://www.4manuals.cc>

<http://www.manual-lib.com>

<http://www.404manual.com>

<http://www.luxmanual.com>

<http://aubethermostatmanual.com>

Golf course search by state

<http://golfingnear.com>

Email search by domain

<http://emailbydomain.com>

Auto manuals search

<http://auto.somanuals.com>

TV manuals search

<http://tv.somanuals.com>