

# ML-75DII

(Gas/Electric/Steam)

## Installation Manual

**WARNING:** For your safety the information in this manual must be followed to minimize the risk of fire or explosion or to prevent property damage, personal injury or death.

— Do not store or use gasoline or other flammable vapor and liquids in the vicinity of this or any other appliance.

— **WHAT DO YOU DO IF YOU SMELL GAS**

- \* Do not try to light any appliance.
- \* Do not touch any electrical switch; do not use any phone in your building.
- \* Clear the room, building or area of all occupants.
- \* Immediately call your gas supplier from a neighbor's phone. Follow the gas supplier's instructions.
- \* If you cannot reach your gas supplier, call the fire department.

— Installation and service must be performed by a qualified installer, service agency or the gas supplier.

**AVERTISSEMENT:** Assurez-vous de bien suivre les instructions données dans cette notice pour réduire au minimum le risque d'incendie ou d'explosion ou pour éviter tout dommage matériel, toute blessure ou la mort.

— Ne pas entreposer ni utiliser d'essence ni d'autres vapeurs ou liquides inflammables dans le voisinage de cet appareil ou de tout autre appareil.

— **QUE FAIRE SI VOUS SENTEZ UNE ODEUR DE GAZ:**

- \* Ne pas tenter d'allumer d'appareil.
- \* Ne touchez à aucun interrupteur. Ne pas vous servir des téléphones se trouvant dans le bâtiment où vous vous trouvez.
- \* Évacuez la pièce, le bâtiment ou la zone.
- \* Appelez immédiatement votre fournisseur de gaz depuis un voisin. Suivez les instructions du fournisseur.
- \* Si vous ne pouvez rejoindre le fournisseur de gaz, appelez le service des incendies.

— L'installation et l'entretien doivent être assurés par un installateur ou un service d'entretien qualifié ou par le fournisseur de gaz.



For replacement parts, contact the reseller from which the dryer was purchased or

**American Dryer Corporation**

88 Currant Road

Fall River MA 02720-4781

Telephone: (508) 678-9000 / Fax: (508) 678-9447

E-mail: techsupport@amdry.com

www.amdry.com

## Retain This Manual In A Safe Place For Future Reference

American Dryer Corporation products embody advanced concepts in engineering, design, and safety. If this product is properly maintained, it will provide many years of safe, efficient, and trouble-free operation.

*ONLY qualified technicians should service this equipment.*

**OBSERVE ALL SAFETY PRECAUTIONS** displayed on the equipment or specified in the installation manual included with the dryer.

The following “**FOR YOUR SAFETY**” caution **must be** posted near the dryer in a prominent location.

### FOR YOUR SAFETY

Do not store or use gasoline or other flammable vapors or liquids in the vicinity of this or any other appliance.

### POUR VOTRE SÉCURITÉ

Ne pas entreposer ni utiliser d'essence ni d'autres vapeurs ou liquides inflammables dans le voisinage de cet appareil ou de tout autre appareil.

We have tried to make this manual as complete as possible and hope you will find it useful. **ADC** reserves the right to make changes from time to time, without notice or obligation, in prices, specifications, colors, and material, and to change or discontinue models.

## Important

For your convenience, log the following information:

DATE OF PURCHASE \_\_\_\_\_ MODEL NO. **ML-75DII** \_\_\_\_\_

RESELLER'S NAME \_\_\_\_\_

Serial Number(s) \_\_\_\_\_

\_\_\_\_\_

\_\_\_\_\_

Replacement parts can be obtained from your reseller or the **ADC** factory. When ordering replacement parts from the factory, you can FAX your order to **ADC** at (508) 678-9447 or telephone your order directly to the **ADC** Parts Department at (508) 678-9000. Please specify the dryer **model number** and **serial number** in addition to the **description** and **part number**, so that your order is processed accurately and promptly.

### “IMPORTANT NOTE TO PURCHASER”

Information **must be** obtained from your local gas supplier on the instructions to be followed if the user smells gas. These instructions **must be** posted in a prominent location near the dryer.

## **IMPORTANT**

**YOU MUST DISCONNECT and LOCKOUT THE ELECTRIC SUPPLY and THE GAS SUPPLY or THE STEAM SUPPLY BEFORE ANY COVERS or GUARDS ARE REMOVED FROM THE MACHINE TO ALLOW ACCESS FOR CLEANING, ADJUSTING, INSTALLATION, or TESTING OF ANY EQUIPMENT per OSHA (Occupational Safety and Health Administration) STANDARDS.**

“Caution: Label all wires prior to disconnection when servicing controls. Wiring errors can cause improper operation.”

«Attention: Lor des opérations d’entretien des commandes étiqueter tous fils avant de les déconnecter. Toute erreur de câblage peut être une source de danger et de panne.»

## **CAUTION**

**DRYER(S) SHOULD NEVER BE LEFT UNATTENDED WHILE IN OPERATION.**

## **WARNING**

**CHILDREN SHOULD NOT BE ALLOWED TO PLAY ON OR NEAR THE DRYER(S).  
CHILDREN SHOULD BE SUPERVISED IF NEAR DRYER(S) IN OPERATION.**

## **FOR YOUR SAFETY**

**DO NOT DRY MOP HEADS IN THE DRYER.  
DO NOT USE DRYER IN THE PRESENCE OF DRY CLEANING FUMES.**

## **WARNING**

**UNDER NO CIRCUMSTANCES should the dryer door switches, lint door switch, heat safety circuit ever be disabled.**

### **WARNING**

The dryer *must never be* operated with any of the back guards, outer tops, or service panels removed. **PERSONAL INJURY or FIRE COULD RESULT.**

### **WARNING**

**DRYER MUST NEVER BE OPERATED WITHOUT THE LINT FILTER/SCREEN IN PLACE...EVEN IF AN EXTERNAL LINT COLLECTION SYSTEM IS USED.**

### **IMPORTANT**

**PLEASE OBSERVE ALL SAFETY PRECAUTIONS** displayed on the equipment and/or specified in the installation manual included with the dryer.

Dryer(s) **must not be** installed or stored in an area where it **will be** exposed to water and/or weather.

The wiring diagram for the dryer is located in the front electrical control box area.

# ***Table of Contents***

## **SECTION I**

<b>IMPORTANT INFORMATION.....</b>	<b>3</b>
A. Receiving and Handling .....	3
B. Safety Precautions .....	4

## **SECTION II**

<b>SPECIFICATIONS/COMPONENT IDENTIFICATION .....</b>	<b>6</b>
A. Specifications .....	6
B. Component Identification .....	8

## **SECTION III**

<b>INSTALLATION PROCEDURES .....</b>	<b>10</b>
A. Location Requirements .....	10
B. Unpacking/Setting Up .....	11
C. Dryer Enclosure Requirements .....	12
D. Fresh Air Supply .....	13
E. Exhaust Requirements .....	14
F. Electrical Information .....	19
G. Gas Information .....	27
H. Steam Information .....	30
I. Preparation For Operation/Start-Up .....	35
J. Preoperational Tests .....	36
K. Preoperational Instructions .....	38
L. Shut Down Instructions .....	39

## **SECTION IV**

<b>SERVICE/PARTS INFORMATION .....</b>	<b>40</b>
A. Service .....	40
B. Parts .....	40

## **SECTION V**

<b>WARRANTY INFORMATION .....</b>	<b>41</b>
A. Returning Warranty Card(s) .....	41
B. Warranty .....	41
C. Returning Warranty Part(s) .....	41

<b>SECTION VI</b>	
<b>ROUTINE MAINTENANCE .....</b>	<b>43</b>
A. Cleaning .....	43
B. Adjustments .....	44
C. Lubrication .....	44
<b>SECTION VII</b>	
<b>PROCEDURE FOR FUNCTIONAL CHECK OF REPLACEMENT</b>	
<b>COMPONENTS .....</b>	<b>46</b>
<b>SECTION VIII</b>	
<b>REVERSING TIMER SPIN/DWELL ADJUSTMENTS.....</b>	<b>49</b>
<b>SECTION IX</b>	
<b>DATA LABEL INFORMATION.....</b>	<b>50</b>
A. Data Label .....	50
<b>SECTION X</b>	
<b>BURNER and BASKET (TUMBLER)/LINT CHAMBER MANUAL RESET</b>	
<b>HI-LIMIT INSTRUCTIONS .....</b>	<b>52</b>
Gas Models Only .....	52
Electric or Steam Models Only .....	53

# SECTION I

## IMPORTANT INFORMATION

### A. RECEIVING and HANDLING

The dryer is shipped in a protective stretch wrap cover with protective cardboard corners and top cover (or optional box) as a means of preventing damage in transit. Upon delivery, the dryer and/or packaging, and wooden skid **should be** visually inspected for shipping damage. If any damage whatsoever is noticed, inspect further before delivering carrier leaves.

Dryers damaged in shipment:

1. **ALL** dryers **should be** inspected upon receipt and before they are signed for.
2. If there is suspected damage or actual damage, the trucker's receipt **should be** so noted.
3. If the dryer is damaged beyond repair, it **should be** refused. Those dryers which were not damaged in a damaged shipment **should be** accepted, but the number received and the number refused **must be** noted on the receipt.
4. If you determine that the dryer was damaged after the trucker has left your location, you should call the delivering carrier's freight terminal immediately and file a claim. The freight company considers this concealed damage. This type of freight claim is very difficult to get paid and becomes extremely difficult when more than a day or two passes after the freight was delivered. It is your responsibility to file freight claims. Dryer/parts damaged in transit **cannot** be claimed under warranty.
5. Freight claims are the responsibility of the consignee, and **ALL** claims **must be** filed at the receiving end. **ADC** assumes no responsibility for freight claims or damages.
6. If you need assistance in handling the situation, please contact the **ADC** Traffic Manager at (508) 678-9000.

**IMPORTANT:** The basket (tumbler) section of the dryer **must be** transported and handled in an upright position at **ALL** times.

## B. SAFETY PRECAUTIONS

**WARNING:** For your safety, the information in this manual *must be* followed to minimize the risk of fire or explosion or to prevent property damage, personal injury, or loss of life.

**WARNING:** The dryer *must never be operated with any of the back guards, outer tops, or service panels removed.* **PERSONAL INJURY or FIRE COULD RESULT.**

1. **DO NOT** store or use gasoline or other flammable vapors and liquids in the vicinity of this or any other appliance.
2. Purchaser/user should consult the local gas supplier for proper instructions to be followed in the event the user smells gas. The instructions **should be** posted in a prominent location.
3. WHAT TO DO IF YOU SMELL GAS...
  - a. **DO NOT** try to light any appliance.
  - b. **DO NOT** touch any electrical switch.
  - c. **DO NOT** use any phone in your building.
  - d. Clear the room, building, or area of **ALL** occupants.
  - e. Immediately call your gas supplier from a neighbor's phone. Follow the gas supplier's instructions.
  - f. If you **cannot** reach your gas supplier, call the fire department.
4. Installation and service **must be** performed by a qualified installer, service agency, or gas supplier.
5. Dryer(s) **must be** exhausted to the outdoors.
6. Although **ADC** produces a very versatile dryer, there are some articles that, due to fabric composition or cleaning method, **should not be** dried in it.

**WARNING:** Dry only water washed fabrics. **DO NOT** dry articles spotted or washed in dry cleaning solvents, a combustible detergent, or "**ALL** purpose" cleaner.  
**EXPLOSION COULD RESULT.**

**WARNING:** **DO NOT** dry rags or articles coated or contaminated with gasoline, kerosene, oil, paint, or wax.  
**EXPLOSION COULD RESULT.**

**WARNING:** **DO NOT** dry mop heads. Contamination by wax or flammable solvents will create a fire hazard.

**WARNING:** **DO NOT** use heat for drying articles that contain plastic, foam, sponge rubber, or similarly textured rubber materials. Drying in a heated basket (tumbler) may damage plastics or rubber and also may be a fire hazard.



7. A program **should be** established for the inspection and cleaning of lint in the heating unit area, exhaust ductwork, and inside the dryer. The frequency of inspection and cleaning can best be determined from experience at each location.

**WARNING:** The collection of lint in the burner area and exhaust ductwork can create a potential fire hazard.

8. For personal safety, the dryer **must be** electrically grounded in accordance with local codes and/or the National Electrical Code ANSI/NFPA NO. 70-LATEST EDITION, or in Canada, the Canadian Electrical Codes Parts 1 & 2 CSA C22.1-1990 or LATEST EDITION.

**NOTE:** Failure to do so will VOID THE WARRANTY.

9. **UNDER NO CIRCUMSTANCES** should the dryer door switches, lint door switch, heat safety circuit ever be disabled.

**WARNING: PERSONAL INJURY or FIRE COULD RESULT.**

10. This dryer is not to be used in the presence of dry cleaning solvents or fumes.
11. Remove articles from the dryer as soon as the drying cycle has been completed.

**WARNING:** Articles left in the dryer after the drying and cooling cycles have been completed can create a fire hazard.

12. **DO NOT** operate steam dryers with more than 125 PSI (8.62 bars) steam pressure. Excessive steam pressure can damage steam coil and/or harm personnel.
13. Replace leaking flexible hoses or other steam fixtures immediately. **DO NOT** operate the dryer with leaking flexible hoses. **PERSONAL INJURY MAY RESULT.**
14. The normal PH level for copper type steam coils **must be** maintained between a value of 8.5 to 9.5. For steel type steam coils the PH level **must be** maintained between a value of 9.5 to 10.5. These limits are set to limit the acid attack of the steam coils.

**IMPORTANT:** Coil failure due to improper PH level will VOID THE WARRANTY.

15. **READ and FOLLOW ALL CAUTION and DIRECTION LABELS ATTACHED TO THE DRYER.**
16. For safety, proper operation, and optimum performance, the dryer **must not be** operated with a load less than sixty-six percent (66%), 50 pounds (22.67 kg) of its rated capacity.

**WARNING: YOU MUST DISCONNECT and LOCKOUT THE ELECTRIC SUPPLY and THE GAS SUPPLY or THE STEAM SUPPLY BEFORE ANY COVERS or GUARDS ARE REMOVED FROM THE MACHINE TO ALLOW ACCESS FOR CLEANING, ADJUSTING, INSTALLATION, or TESTING OF ANY EQUIPMENT per OSHA (Occupational Safety and Health Administration) STANDARDS.**

# SECTION II

## SPECIFICATIONS/COMPONENT IDENTIFICATION

### A. SPECIFICATIONS

BASKET (TUMBLER) DIAMETER		37"	<b>94 cm</b>	
BASKET (TUMBLER) DEPTH		36"	<b>91.5 cm</b>	
BASKET (TUMBLER) MOTOR		1 HP*	<b>0.746 kw</b>	
DOOR OPENING (DIAMETER)		31-3/8"	<b>79.7 cm</b>	
BASKET (TUMBLER) VOLUME		22.4 cu. ft.	<b>0.634 cu. m.</b>	
DRYERS PER 20'/40' CONTAINER		10/20		
DRYERS PER 45'/48' TRUCK		24/24		
<b>Gas</b>	VOLTAGE AVAILABLE		120-460v 1 $\phi$ -3 $\phi$ 50/60 Hz	
	APPROX. WEIGHT (UNCRATED)		721 lbs. <b>327 kg</b>	
	APPROX. WEIGHT (CRATED)		771 lbs. <b>349.7 kg</b>	
	HEAT INPUT		200,000 btu/hr <b>50,400 kcal/hr</b>	
	AIRFLOW		1,200 cfm <b>33.98 cmm</b>	
	INLET PIPE SIZE		3/4" N.P.T.**	
<b>Electric</b>	VOLTAGE AVAILABLE		208-460v 1 $\phi$ -3 $\phi$ 50/60 Hz	
	APPROX. WEIGHT (UNCRATED)		721 lbs. <b>327 kg</b>	
	APPROX. WEIGHT (CRATED)		771 lbs. <b>349.7 kg</b>	
	AIRFLOW		1,200 cfm <b>33.98 cmm</b>	
<b>Steam</b>	VOLTAGE AVAILABLE		120-460v 1 $\phi$ -3 $\phi$ 50/60 Hz	
	APPROX. WEIGHT (UNCRATED)		757 lbs. <b>343.4 kg</b>	
	APPROX. WEIGHT (CRATED)		807 lbs. <b>366.1 kg</b>	
	AIRFLOW		1,350 cfm <b>38.23 cmm</b>	
	COMPRESSED AIR VOLUME		0.75 cfh <b>0.02 cmh</b>	
	AIR CONNECTION		1/8" F.P.T.	
	STEAM CONSUMPTION		BOILER HP NORMAL LOAD	
	238.7 lbs./hr	<b>108.3 kg/hr</b>	7	
	OPERATING STEAM PRESSURE		STEAM SUPPLY	STEAM RETURN
	125 PSI max	<b>8.6 bars</b>	1" F.P.T.	1" F.P.T.

*Shaded areas are stated in metric equivalents*

\* For non-reversing models.

\*\* A minimum of 3/4-inch pipe **must be** supplied to the gas inlet for each dryer.

**IMPORTANT:** Steam dryers *must be* provided with clean, dry, and regulated 80 PSI +/- 10 PSI (5.51 bars +/- 0.69 bars) air supply.

**NOTE:** ADC reserves the right to make changes in specifications at any time without notice or obligation.

# Specifications

## MLG-75D

## MLE-75

## MLS-75

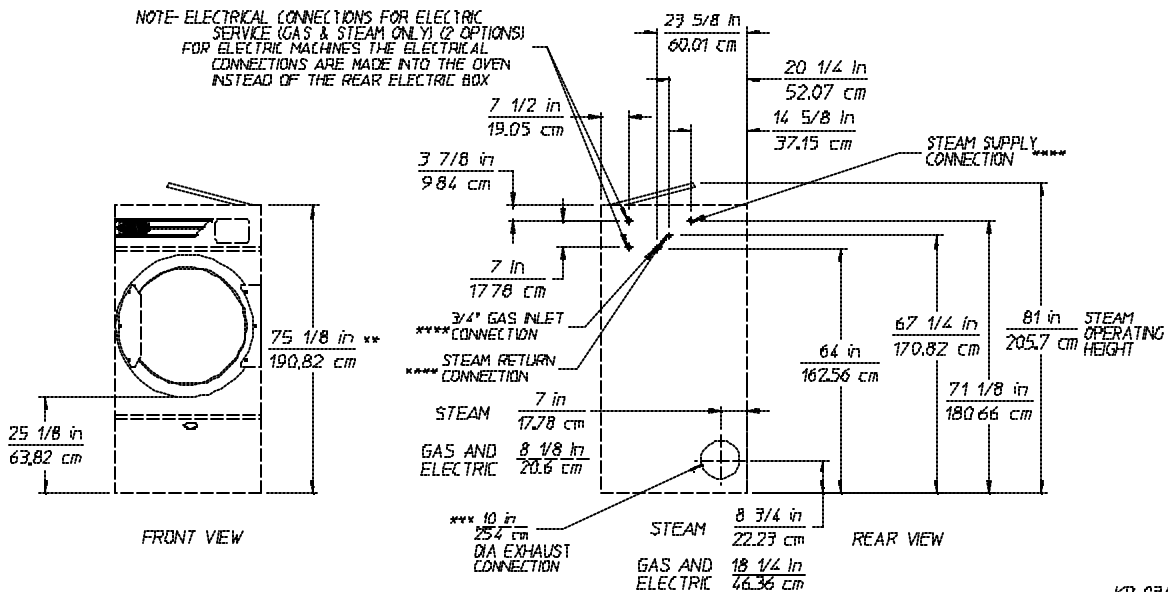
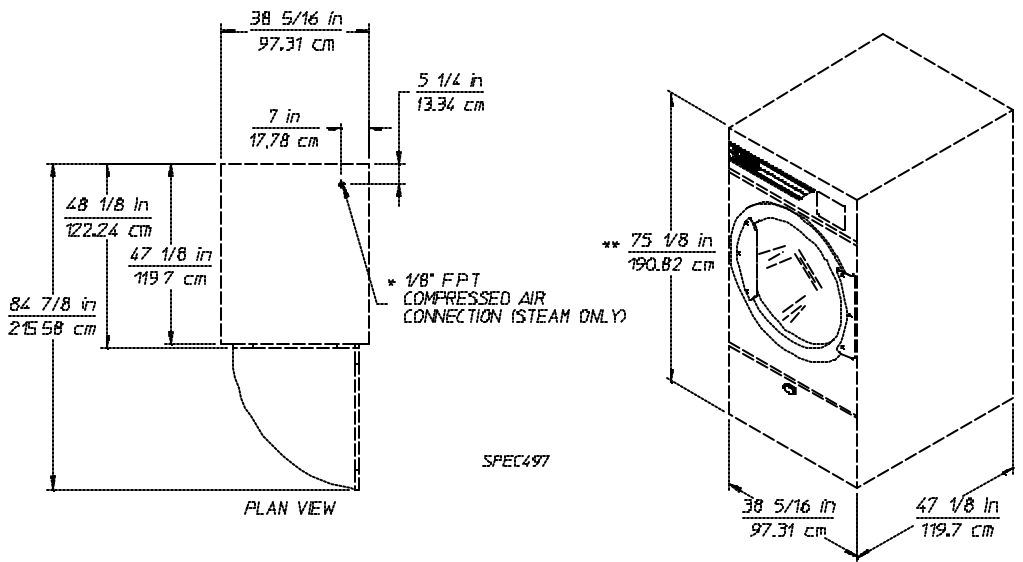

KP 09/20/01

- \* STEAM DRYER MUST BE PROVIDED WITH CLEAN, DRY, REGULATED 80 PSI ± 10 PSI (5.51 BAR ± 0.69 BAR) AIR SUPPLY
- \*\* OPERATING HEIGHT FOR STEAM UNIT IS 81" (20574 cm).
- \*\*\* DUCT WORK SIZE VARIES WITH INSTALLATION CONDITIONS. EXHAUST STATIC PRESSURE SHOULD NOT EXCEED 0.3 INCHES (074 mb) WATER COLUMN
- \*\*\*\* SIZE OF PIPING TO DRYER VARIES WITH INSTALLATION CONDITIONS. CONTACT FACTORY FOR ASSISTANCE.

**NOTE:** ADC reserves the right to make changes in specifications at any time without notice or obligation.

## B. COMPONENT IDENTIFICATION

### 1. Dryer Front View

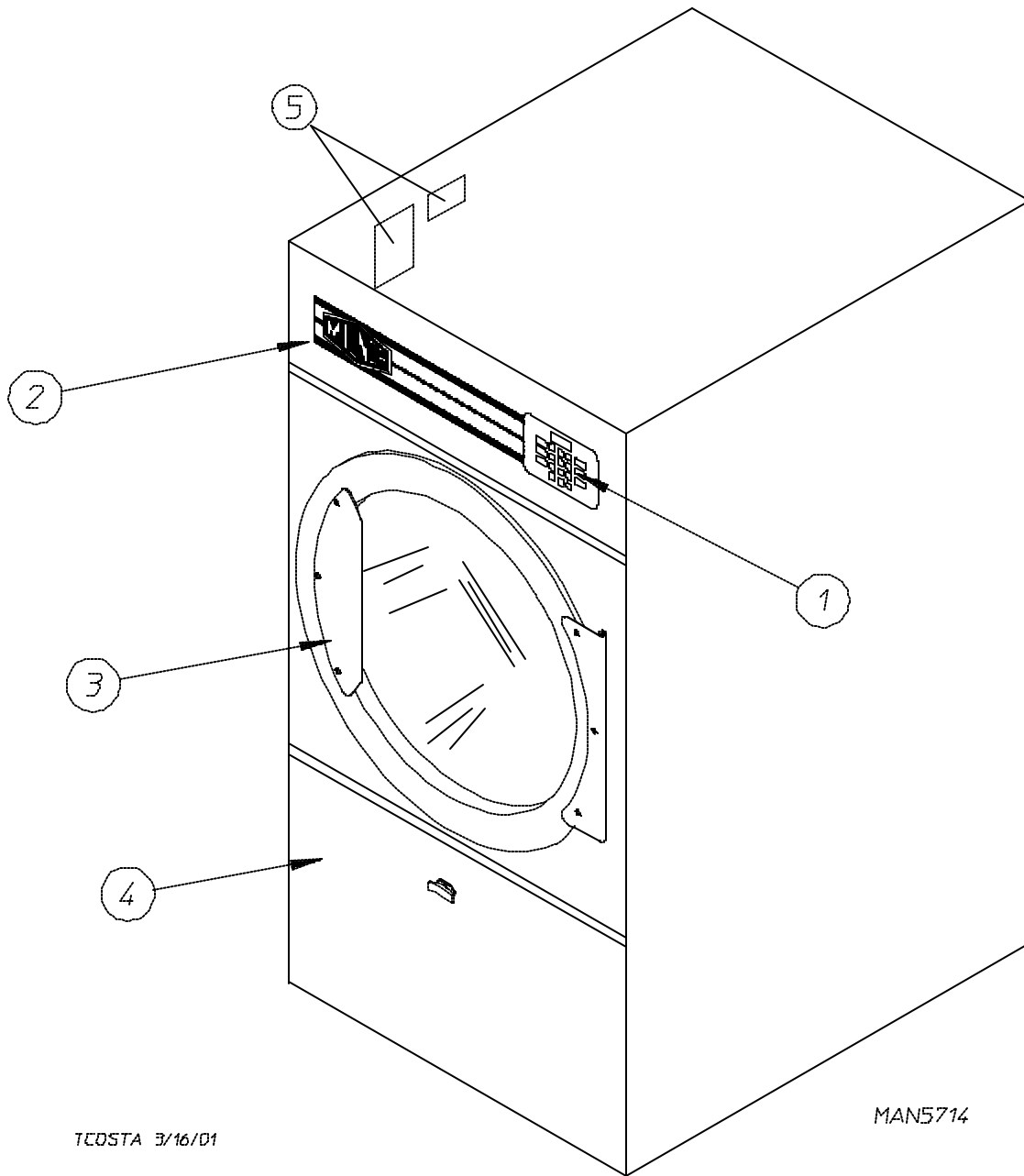

<u>Illus. No.</u>	<u>Description</u>
-------------------	--------------------

- |   |  |
|---|--|
| 1 | Controls   |
| 2 | Control (top access) Door Assembly   |
| 3 | Main Door Assembly   |
| 4 | Lint Compartment Area (lint screen located behind door)  |
| 5 | Data Label and Installation Label (located on the left side panel/wall area behind the control door) |

## 2. Dryer Rear View

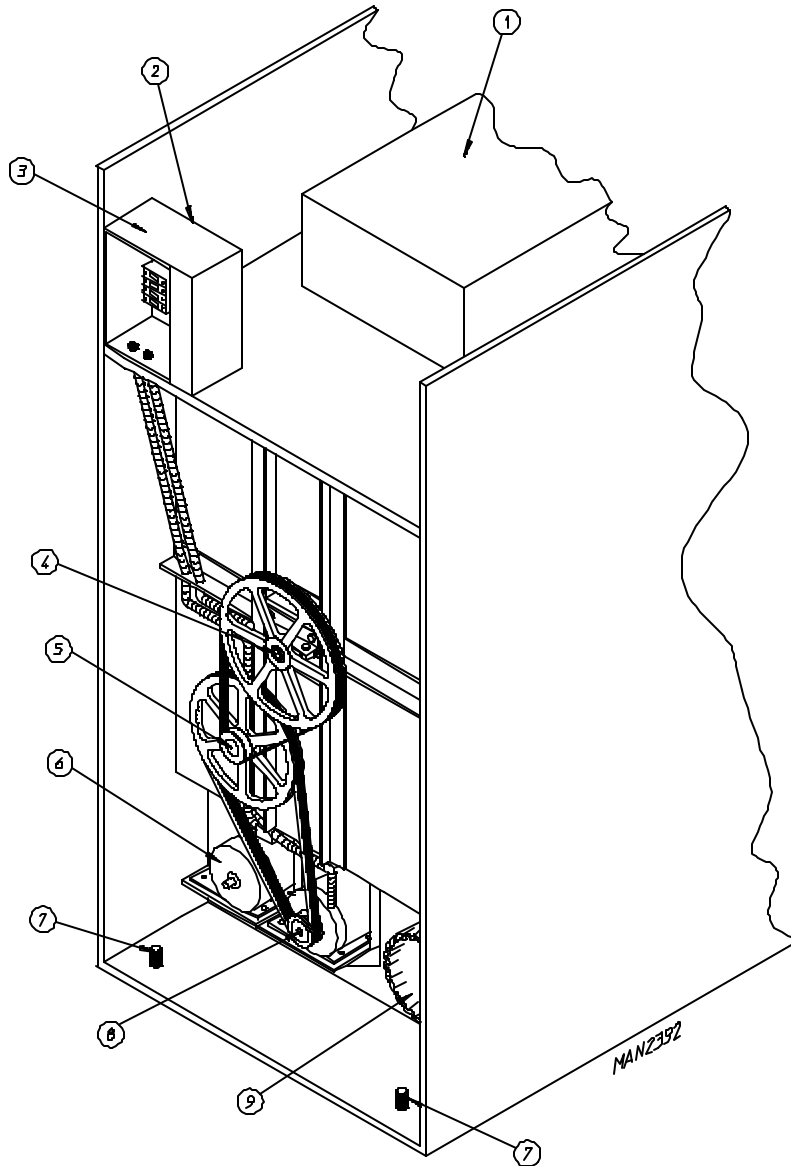

<u>Illus. No.</u>	<u>Description</u>
1	Heating Unit
2	1/8-inch Compressed Air Supply Inlet (behind electric service relay box for steam units Only)
3*	Electric Service Relay Box
4	Basket (tumbler) Bearing Mount Assembly
5	Idler Bearing Mount Assembly
6	Blower Motor Assembly
7	Leveling Leg (rear)
8	Basket (tumbler) Drive Motor Assembly (reversing models Only)
9	Dryer Exhaust

\* Electric service connections for gas and steam models are made in this box.

**NOTE:** 1/8-inch compressed air supply inlet (for steam models only) is located behind the electric service relay box.

# SECTION III

## INSTALLATION PROCEDURES

Installation **should be** performed by competent technicians in accordance with local and state codes. In the absence of these codes, the installation **must conform** to applicable American National Standards: ANSI Z223.1-LATEST EDITION (National Fuel Gas Code) or ANSI/NFPA NO. 70-LATEST EDITION (National Electrical Code) or in Canada, the installation **must conform** to applicable Canadian Standards: CAN/CGA-B149.1-M91 (Natural Gas) or CAN/CGA-B149.2-M91 (Liquid Propane [L.P.] Gas) or LATEST EDITION (for General Installation and Gas Plumbing) or Canadian Electrical Codes Parts 1 & 2 CSA C22.1-1990 or LATEST EDITION (for Electrical Connections).

### A. LOCATION REQUIREMENTS

Before installing the dryer, be sure the location conforms to local codes and ordinances. In the absence of such codes or ordinances the location **must conform** with the National Fuel Gas Code ANSI.Z223.1 LATEST EDITION, or in Canada, the installation **must conform** to applicable Canadian Standards: CAN/CGA-B149.1-M91 (Natural Gas) or CAN/CGA-B149.2-M91 (L.P. Gas) or LATEST EDITION (for General Installation and Gas Plumbing).

1. The dryer **must be** installed on a sound level floor capable of supporting its weight. Carpeting **must be** removed from the floor area that the dryer is to rest on.

**IMPORTANT:** “The dryer *must be* installed on noncombustible floors only.”

2. The dryer **must not be** installed or stored in an area where it will be exposed to water and/or weather.
3. The dryer is for use in noncombustible locations.
4. Provisions for adequate air supply **must be** provided as noted in this manual (refer to **Fresh Air Supply** in Section D).
5. Clearance provisions **must be** made from combustible construction as noted in this manual (refer to **Dryer Enclosure Requirements** in Section C).
6. Provisions **must be** made for adequate clearances for servicing and for operation as noted in this manual (refer to **Dryer Enclosure Requirements** in Section C).
7. Dryer **must be** exhausted to the outdoors as noted in this manual (refer to **Exhaust Requirements** in Section E).
8. Dryer **must be** located in an area where correct exhaust venting can be achieved as noted in this manual (refer to **Exhaust Requirements** in Section E).
9. The dryer **must be** installed with a proper exhaust duct connection to the outside.
10. The dryer **must be** installed with provisions for adequate combustion and make-up air supply.

**CAUTION:** This dryer produces combustible lint and must be exhausted to the outdoors. Every 6 months, inspect the exhaust ducting and remove any lint build up.

**IMPORTANT:** Dryer *should be* located where a minimum amount of exhaust duct will be necessary.

## B. UNPACKING/SETTING UP

Remove protective shipping material (i.e., plastic wrap, and/or optional shipping box) from dryer.

**IMPORTANT:** Dryer *must be* transported and handled in an upright position at ALL times.

The dryer can be moved to its final location while still attached to the skid or with the skid removed. To unskid the dryer, locate and remove the four (4) bolts securing the base of the dryer to the wooden skid. Two (2) are at the rear base (remove the back panel for access), and two (2) are located in the bottom of the lint chamber. To remove the two (2) bolts located in the lint chamber area, remove the lint door.

With the skid removed, to make it easier to slide the dryer into its final position, slightly lower ALL four (4) leveling legs, so that the dryer will slide on the legs instead of the base frame.

To increase bearing life and improve efficiency, the dryer **should be** tilted slightly to the rear.

**IMPORTANT:** For microprocessor controller (computer) models, this wooden block *must be removed before connecting power to the dryer or irreparable damage to the basket (tumbler) will result.*

The lint coops of ALL ML-75 dryers are supported during shipping by a bracket. **REMOVE THIS BRACKET BEFORE STARTING THE DRYER.**

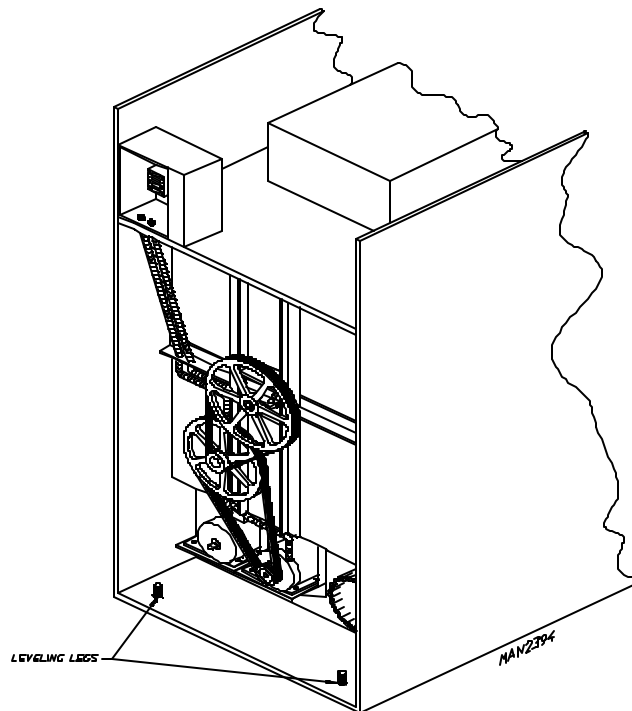

### 1. Leveling Dryer

The dryer is equipped with four (4) leveling legs, one (1) at each corner of the base. Two (2) are located at the rear of the dryer base, and two (2) are located in the lint chamber (coop). To increase bearing life and improve efficiency, the dryer **should be** tilted slightly to the rear.

## C. DRYER ENCLOSURE REQUIREMENTS

Bulkheads and partitions **should be** made of noncombustible materials and **must be** located a minimum of 12-inches (30.48 cm), 18-inches (45.72 cm) or more is recommended for ease of installation, maintenance, and service above the dryer outer top, except along the front of the dryer which may be partially closed in if desired. The clearance between the bulkhead header and the dryer **must be** a minimum of 4-inches (10.16 cm) and **must not** extend more than 4-inches (10.16 cm) to the rear of the front. The bulkhead facing **must not be** closed in **ALL** the way to the top of the dryer. A 1-inch (2.54 cm) clearance is required.

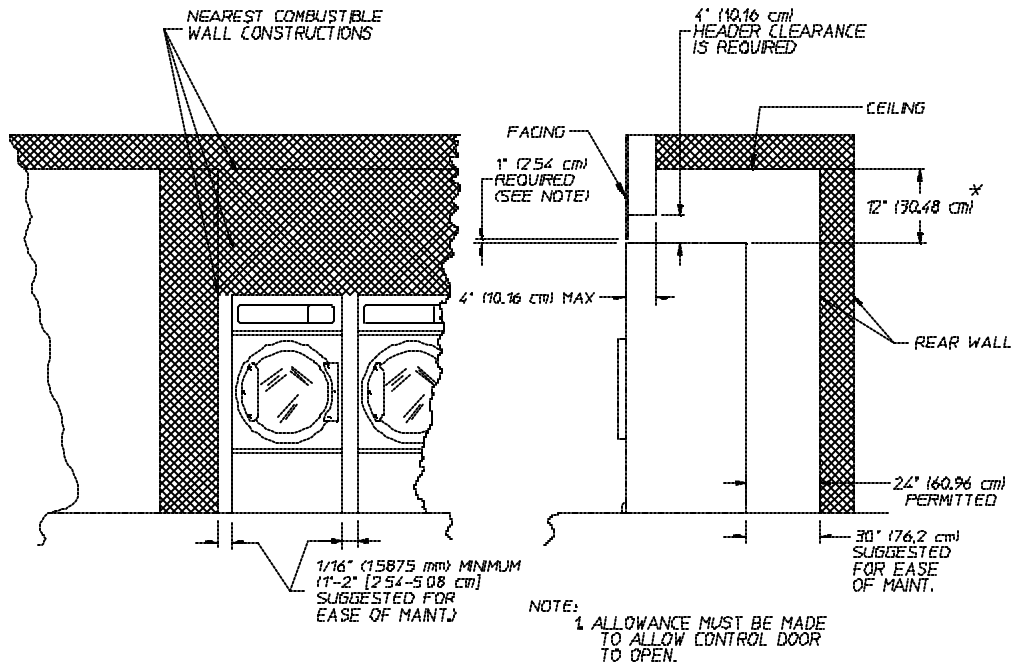

\*IN CASES WHERE SPRINKLER HEADS ARE OVER THE DRYERS 18" (45.72 cm) IS SUGGESTED.

INSTALLATION. DRYER CLEARANCE TO ADJACENT WALL STRUCTURES.

TEOSTA 7/16/01

MAN4852A

**NOTE:** Allowances **must be** made for opening the control door.

Dryers may be positioned sidewall to sidewall. However, a 1/16-inch (1.5875 mm) minimum allowance **must be** made for the opening and closing of the control door and the lint door. It is suggested that the dryer be positioned about 30-inches (76.2 cm) away from the nearest obstruction for ease of installation, maintenance, and service (to be measured from the back guard.) Refer to the **illustration above** for details.

**NOTE:** Air considerations are important for proper and efficient operation.

**IMPORTANT:** For overhead clearance, even though a minimum of only 12-inches (30.48 cm) is required, 18-inches (45.72 cm) or more is suggested. The additional clearance is advantageous for ease of installation and service.

**IMPORTANT:** When fire sprinkler systems are located above the dryers, a minimum of 18-inches (45.72 cm) above the dryer console (module) is required. Dryers may be positioned sidewall to sidewall however, a 1/16-inch (1.5875 mm) minimum allowance is required between dryers (or wall) for ease of installation and maintenance. Allowances **must be** made for the opening and closing of the control door and the lint door.



## D. FRESH AIR SUPPLY

When the dryer is operating, it draws in room air, heats it, passes this air through the basket (tumbler), and exhausts it out of the building. Therefore, the room air **must be** continually replenished from the outdoors. If the make-up air is inadequate, drying time and drying efficiency will be adversely affected. Ignition problems and sail switch “fluttering” problems may result, as well as premature motor failure from overheating.

Air supply (make-up air) **must be** given careful consideration to assure proper performance of each dryer. An unrestricted source of air is necessary for each dryer. An airflow of 1,200 cfm (cubic feet per minute) - 33.98 cmm (cubic meters per minute) - **must be** supplied to each gas and electric dryer and 1,350 cfm (38.23 cmm) **must be** supplied to each steam dryer. As a general rule, an unrestricted air entrance from the outdoors (atmosphere) of a minimum of 1-1/2 square feet (0.14 square meters) is required for each dryer.

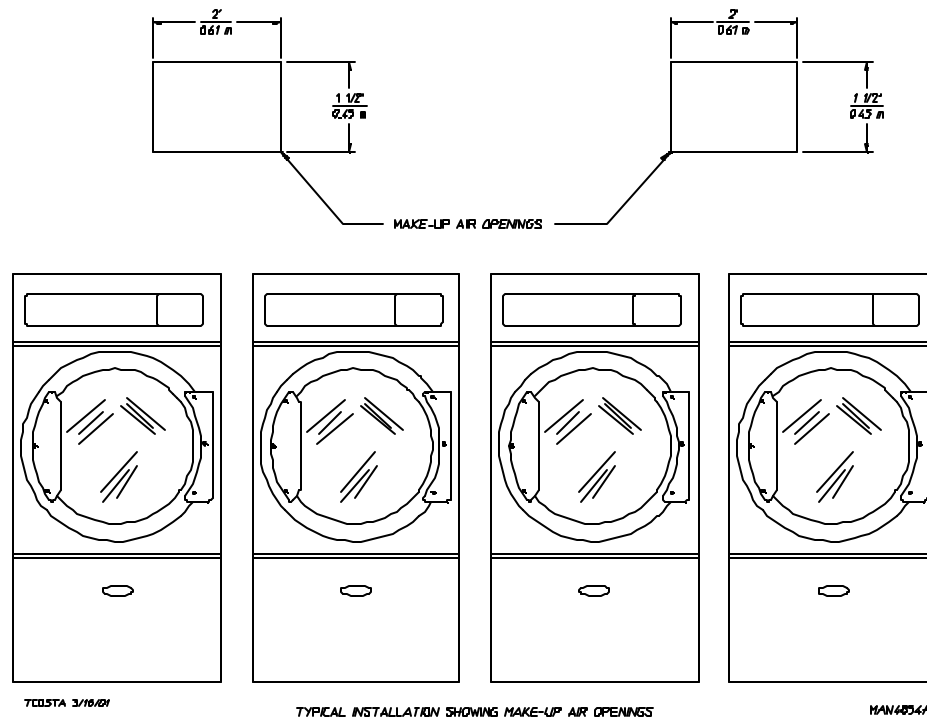

To compensate for the use of registers or louvers used over the openings, this make-up air **must be** increased by approximately thirty-three percent (33%). Make-up air openings **should not be** located in an area directly near where exhaust vents exit the building.

It is not necessary to have a separate make-up air opening for each dryer. Common make-up air openings are acceptable. However, they **must be** set up in such a manner that the make-up air is distributed equally to ALL the dryers. The dryer **must be** installed with provisions for adequate combustion and make-up air supply.

EXAMPLE: For a bank of four (4) dryers, two (2) unrestricted openings measuring 2 feet by 1-1/2 feet (0.61 meters by 0.45 meters), 6 square feet (0.56 square meters) is acceptable.

Allowances **must be** made for remote or constricting passageways or where dryers are located at excessive altitudes or predominantly low pressure areas.

**IMPORTANT:** Make-up air **must be** provided from a source free of dry cleaning solvent fumes. Make-up air that is contaminated by dry cleaning solvent fumes will result in irreparable damage to the motors and other dryer components.

**NOTE:** Component failure due to dry cleaning solvent fumes will VOID THE WARRANTY.

## E. EXHAUST REQUIREMENTS

### 1. General Exhaust Ductwork Information

Exhaust ductwork **should be** designed and installed by a qualified professional. Improperly sized ductwork will create excessive back pressure which results in slow drying, increased use of energy, overheating of the dryer, and shutdown of the burner by the airflow (sail) switches, burner hi-limits, or basket (tumbler) hi-heat thermostats. The dryer **must be** installed with a proper exhaust duct connection to the outside.

**CAUTION:** This dryer produces combustible lint and must be exhausted to the outdoors.

**CAUTION:** DRYER **MUST BE** EXHAUSTED TO THE OUTDOORS.

**CAUTION:** IMPROPERLY SIZED or INSTALLED EXHAUST DUCTWORK CAN CREATE A POTENTIAL FIRE HAZARD.

The ductwork **should be** laid out in such a way that the ductwork travels as directly as possible to the outdoors with as few turns as possible. Single or independent dryer venting is recommended.

#### **Horizontal Venting:**

When single dryer venting is used, the length of ductwork from the dryer to the outside exhaust outlet, **must not exceed** 15 feet (4.6 meters). The minimum diameter of this ductwork **must be** at least 10-inches (25.4 cm). In the case of multiple (common) dryer venting, the distance from the last dryer to the outside exhaust outlet **must not exceed** 15 feet (4.6 meters). The shape of the ductwork is not critical so long as the minimum cross-sectional area is provided. It is suggested that the use of 90° turns be avoided; use 30° and/or 45° angles instead. The radius of the elbows **should preferably be** 1-1/2 times the diameter of the duct. Including basket (tumbler)/dryer elbow connections or elbows used for outside protection from the weather, no more than two (2) elbows **should be** used in the exhaust duct run. If more than two (2) elbows are used, the cross-sectional area of the ductwork **must be** increased. ALL ductwork **should be** smooth inside with no projections from sheet metal screws or other obstructions, which will collect lint. When adding ducts, the duct to be added should overlap the duct to which it is to be connected. ALL ductwork joints **must be** taped to prevent moisture and lint from escaping into the building. Inspection doors **should be** installed at strategic points in the exhaust ductwork for periodic inspection and cleaning of lint from the ductwork.

#### **Vertical Venting:**

When single dryer venting is used, the length of the ductwork from the dryer to the outside exhaust outlet **must not exceed** 20 feet (6.1 meters). The minimum diameter of this ductwork **must be** at least 12-inches (30.48 cm) even though the dryer exhaust duct for gas and electric units is only 10-inches (25.4 cm). In the case of multiple (common) dryer venting, the distance from the last dryer to the outside exhaust outlet **should not exceed** 20 feet (6.1 meters). The shape of the ductwork is not so critical so long as the minimum cross-sectional area is provided. It is suggested that the use of 90° turns be avoided; use 30° and/or 45° bends instead. The radius of the elbows **should preferably be** 1-1/2 times the diameter of the duct. ALL ductwork **should be** smooth inside with no projections from sheet metal screws or other obstructions, which will collect lint. When adding ducts, the duct to be added should overlap the duct to which it is to be connected. ALL ductwork joints **must be** taped to prevent moisture and lint from escaping into the building. Inspection doors **should be** installed at strategic points in the exhaust ductwork for periodic inspection and cleaning of lint from the ductwork.

**IMPORTANT:** Exhaust back pressure measured by a manometer in the exhaust duct **must not exceed** 0.3 inches (0.74 mb) of water column (W.C.).

**IMPORTANT:** Minimum ductwork diameter for horizontal venting is 10-inches (25.4 cm) and for vertical venting the minimum is 12-inches (30.48 cm).

**NOTE:** When the exhaust ductwork passes through a wall, ceiling, or roof made of combustible materials, the opening *must be* 2-inches (5.08 cm) larger than the duct (**ALL** the way around). The duct *must be* centered within this opening.

a. Outside Ductwork Protection

- 1) To protect the outside end of horizontal ductwork from the weather, a 90° elbow bent downward **should be** installed where the exhaust exits the building. If the ductwork travels vertically up through the roof, it **should be** protected from the weather by using a 180° turn to point the opening downward. In either case, allow at least twice the diameter of the duct between the duct opening and the nearest obstruction.

**IMPORTANT:** *DO NOT* use screens, louvers, or caps on the outside opening of the exhaust ductwork.

VERTICAL DUCTING

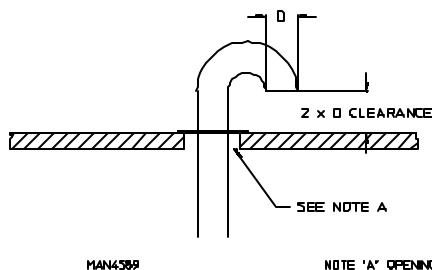

HORIZONTAL DUCTING

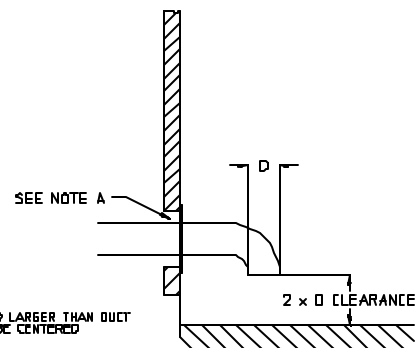

NOTE 'A' OPENING MUST BE TWO (2) INCHES (50.8 MM) LARGER THAN DUCT (ALL THE WAY AROUND) THE DUCT MUST BE CENTERED WITHIN THIS OPENING

2. Single Dryer Venting

Where possible, it is suggested to provide a separate exhaust duct for each dryer. The exhaust duct **should be** laid out in such a way that the ductwork travels as directly as possible to the outdoors with as few turns as possible. It is suggested that the use of 90° turns in the ducting be avoided; use 30° and/or 45° angles instead. The shape of the exhaust ductwork is not critical so long as the minimum cross section area is provided.

**IMPORTANT:** Minimum duct size for a dryer that is vented horizontally is 10-inches (25.4 cm) for a round duct or an equivalent of 80 square inches (516 square centimeters). **THE DUCT SIZE MUST NOT BE REDUCED ANYWHERE DOWNSTREAM OF THE DRYER.**

**IMPORTANT:** Exhaust back pressure measured by a manometer at each basket (tumbler) exhaust duct area *must not exceed* 0.3 inches (0.74 mb) of water column (W.C.).

**IMPORTANT:** Minimum duct size for a dryer that is vented vertically is 12-inches (30.48 cm) for a round duct or an equivalent of 120 square inches (774 square centimeters). **THE DUCT SIZE MUST NOT BE REDUCED ANYWHERE DOWNSTREAM OF THE DRYER.**

## SINGLE DRYER VENTING

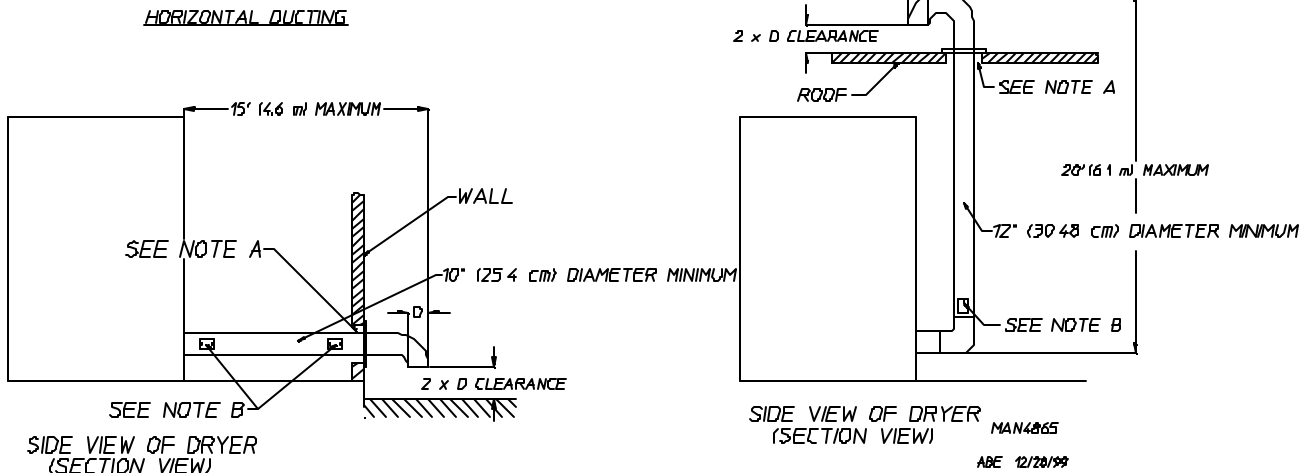

- NOTE "A"- OPENING MUST BE TWO (2) INCHES (5.08 cm) LARGER THAN DUCT (ALL THE WAY AROUND). THE DUCT MUST BE CENTERED WITHIN THIS OPENING
- "B"- INSPECTION DOORS SHOULD BE INSTALLED AT STRATEGIC POINTS FOR PERIODIC INSPECTION AND CLEANING

**IMPORTANT:** For extended ductwork runs, the cross section area of the ductwork can only be increased to an extent. When the ductwork approaches the maximum limits noted in this manual, a professional heating, venting, and air conditioning (HVAC) firm *should be* consulted for proper venting information.

**ALL** ductwork **should be** smooth inside with no projections from sheet metal screws or other obstructions which will collect lint. When adding ducts, the duct to be added should overlap the duct to which it is to be connected. **ALL** ductwork joints **must be** taped to prevent moisture and lint from escaping into the building. Inspection doors **should be** installed at strategic points in the exhaust ductwork for periodic inspection and cleaning of lint from the ductwork.

**NOTE:** When the exhaust ductwork passes through a wall, ceiling, or roof made of combustible materials, the opening **must be** 2-inches (5.08 cm) larger than the duct (**ALL** the way around). The duct **must be** centered within this opening.

### a. Outside Ductwork Protection

- 1) To protect the outside end of horizontal ductwork from the weather, a 90° elbow bent downward **should be** installed where the exhaust exits the building. If the ductwork travels vertically up through the roof, it **should be** protected from the weather by using a 180° turn to point the opening downward. In either case, allow at least twice the diameter of the duct between the duct opening and the nearest obstruction.

**IMPORTANT:** **DO NOT** use screens, louvers, or caps on the outside opening of the exhaust ductwork.

### 3. Multiple Dryer (Common) Venting

If it is not feasible to provide separate exhaust ducts for each dryer, ducts from individual dryers may be channeled into a “common main duct.” The individual ducts should enter the bottom or side of the main duct at an angle not more than 45° in the direction of airflow and **should be** spaced at least 38-5/16” (97.31 cm) apart. The main duct **should be** tapered, with the diameter increasing before each individual duct (10-inch [25.4 cm] minimum) is added.

**IMPORTANT:** No more than four (4) dryers **should be** connected to main common duct.

The main duct may be any shape so long as the minimum cross section area is provided. The **illustration** on **page 18** shows the minimum cross section area for multiple dryer round or square venting. These figures **must be** increased 10 square inches (64.52 square centimeters) when rectangular main ducting is used, and the ratio of duct width to depth **should not be** greater than 3-1/2 to 1. These figures **must be** increased in proportion if the main duct run from the last dryer to where it exhausts to the outdoors is unusually long (over 15 feet [4.6 meters]) or has numerous (more than two [2] elbows in it). In calculating ductwork size, the cross section area of a square or rectangular duct **must be** increased twenty percent (20%) for each additional 15 feet (4.6 meters). The diameter of a round exhaust **must be** increased ten percent (10%) for each additional 15 feet (4.6 meters). Each 90° elbow is equivalent to an additional 30 feet (9.14 meters) and each 45° elbow is equivalent to an additional 15 feet (4.6 meters).

**IMPORTANT:** For extended ductwork runs, the cross section area of the ductwork can only be increased to an extent. Maximum proportional ductwork runs **cannot** exceed 15 feet (4.6 meters) with two (2) elbows. When the ductwork approaches the maximum limits as noted in this manual, a professional heating, venting, and air conditioning (HVAC) firm **should be** consulted for proper venting information.

The ductwork **should be** smooth inside with no projections from sheet metal screws or other obstructions, which will collect lint. When adding ducts, the duct to be added should overlap the duct to which it is to be connected. **ALL** ductwork joints **must be** taped to prevent moisture and lint from escaping into the building. Inspection doors **should be** installed at strategic points in the exhaust ductwork for periodic inspection and cleaning of lint from the ductwork.

**NOTE:** When the exhaust ductwork passes through a wall, ceiling, or roof made of combustible materials, the opening **must be** 2-inches (2.54 cm) larger than the duct (**ALL** the way around). The duct **must be** centered within this opening.

#### a. Outside Ductwork Protection

- 1) To protect the outside end of horizontal ductwork from weather, a 90° elbow bent downward **should be** installed where the exhaust exits the building. If the ductwork travels vertically up through the roof, it **should be** protected from the weather by using a 180° turn to point the opening downward. In either case, allow at least twice the diameter of the duct between the duct opening and the nearest obstruction.

**IMPORTANT:** **DO NOT** use screens, louvers, or caps on the outside opening of the exhaust ductwork.

MULTIPLE DRYER VENTING (MLG-75/MLE-75) WITH 10" (25.4 CM) DIAMETER  
1200 CFM (33.98 CMM) EXHAUST CONNECTIONS AT COMMON DUCT

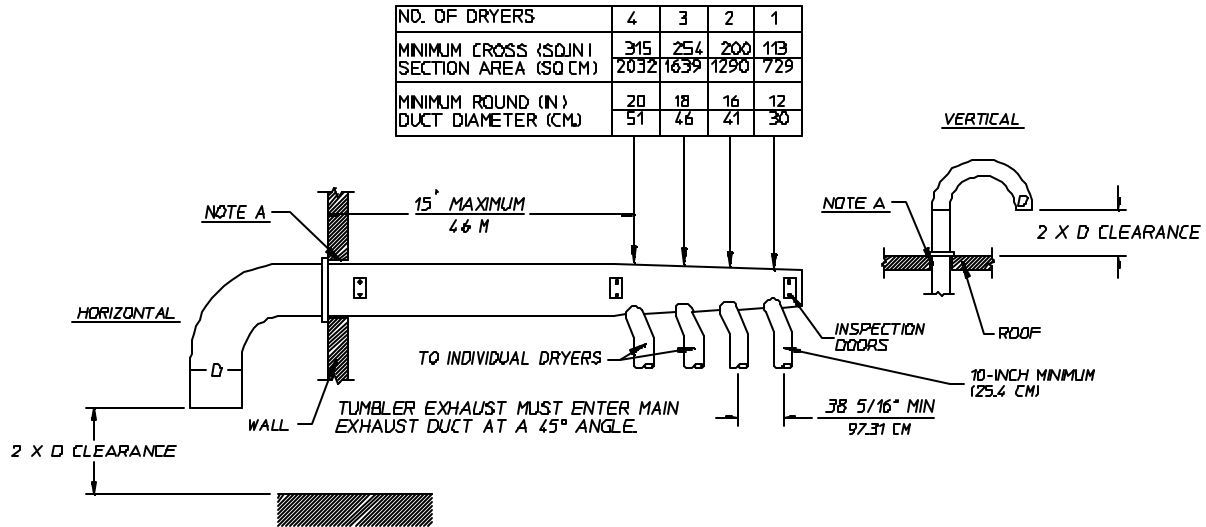

IMPORTANT: NO MORE THAN 4 DRYERS CAN  
BE CONNECTED TO ONE COMMON DUCT ( VENT ).

RAR 03/20/01

MAN5715

FORMULAS TO CALCULATE DUCTING CROSS SECTIONAL AREA

CROSS SECTIONAL AREA OF A ROUND DUCT =  $.785 (19.939 \text{ mm}) \times D^2$  WHERE D = DIAMETER OF THE DUCT.

CROSS SECTIONAL AREA OF A RECTANGULAR DUCT =  $W \times H$  WHERE W = WIDTH AND H = HEIGHT

NOTE A: OPENING MUST BE 2-INCHES (5.08 CM) LARGER THAN THE DUCT (ALL THE WAY AROUND).  
THE DUCT MUST BE CENTERED WITHIN THIS OPENING.

MULTIPLE DRYER VENTING (MLS-75) WITH 10" (25.4 CM) DIAMETER  
1350 CFM (38.23 CMM) EXHAUST CONNECTIONS AT COMMON DUCT

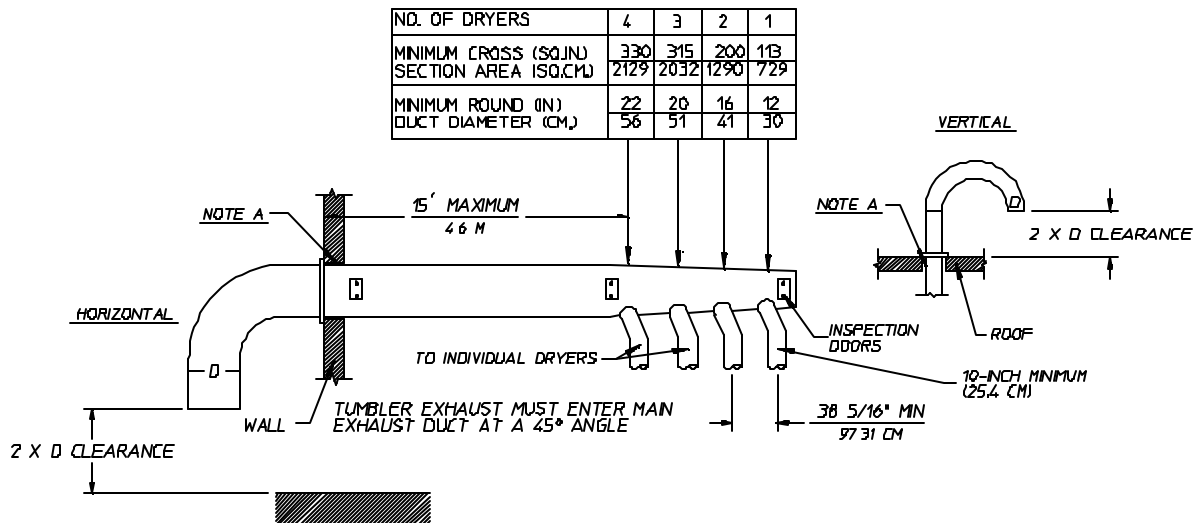

IMPORTANT: NO MORE THAN 4 DRYERS CAN  
BE CONNECTED TO ONE COMMON DUCT ( VENT ).

RAR 03/20/01

MAN5716

FORMULAS TO CALCULATE DUCTING CROSS SECTIONAL AREA

CROSS SECTIONAL AREA OF A ROUND DUCT =  $.785 (19.939 \text{ mm}) \times D^2$  WHERE D = DIAMETER OF THE DUCT.

CROSS SECTIONAL AREA OF A RECTANGULAR DUCT =  $W \times H$  WHERE W = WIDTH AND H = HEIGHT.

NOTE A: OPENING MUST BE 2-INCHES (5.08 CM) LARGER THAN THE DUCT (ALL THE WAY AROUND).  
THE DUCT MUST BE CENTERED WITHIN THIS OPENING.

## F. ELECTRICAL INFORMATION

### 1. Electrical Requirements

It is your responsibility to have **ALL** electrical connections made by a properly licensed and competent electrician to assure that the electrical installation is adequate and conforms to local and state regulations or codes. In the absence of such codes, **ALL** electrical connections, materials, and workmanship **must conform** to the applicable requirements of the National Electrical Code ANSI/NFPA NO. 70-LATEST EDITION or in Canada, the Canadian Electrical Codes Parts 1 & 2 CSA C22.1-1990 or LATEST EDITION.

**IMPORTANT:** Failure to comply with these codes or ordinances, and/or the requirements stipulated in this manual can result in personal injury or component failure.

**NOTE:** Component failure due to improper installation will VOID THE WARRANTY.

Each dryer **should be** connected to an independently protected branch circuit. The dryer **must be** connected with copper wire only. **DO NOT** use aluminum wire, which could cause a fire hazard. The copper conductor wire/cable **must be** of proper ampacity and insulation in accordance with electric codes for making **ALL** service connections.

**NOTE:** The use of aluminum wire will VOID THE WARRANTY.

**IMPORTANT:** A separate circuit servicing each dryer **must be** provided.

## 2. Electrical Service Specifications

### a. Gas and Steam Models Only

# MLG-75 (Gas) MLS-75 (Steam)

## ELECTRICAL SERVICE SPECIFICATIONS (PER DRYER)

**IMPORTANT:** 208 VAC and 240 VAC ARE NOT THE SAME. When ordering, specify *exact voltage*.

- NOTES:**
- A. Fuse ratings are dual element, time delay, current limiting, class RK1 or RK5 **ONLY**.
  - B. Circuit breakers are thermal/magnetic (industrial) motor curve type **ONLY**. For others, calculate/verify correct breaker size according to appliance amp draw rating and type of breaker used.
  - C. Circuit breakers for 3-phase (3 $\phi$ ) dryers **must be** 3-pole type.

SERVICE VOLTAGE	PHASE	WIRE SERVICE	APPROX. AMP DRAW	MINIMUM WIRE SIZE	FUSING	CIRCUIT BREAKER
					Dual Element Time Delay	
120 (60 Hz)	1 $\phi$	2	13	*	20	25
208 (60 Hz)	1 $\phi$	2	7.6	*	12	15
208 (60 Hz)	3 $\phi$	3/4	4.7	*	8	15
240 (50/60 Hz)	1 $\phi$	2	7	*	12	15
240 (50/60 Hz)	3 $\phi$	3/4	4.9	*	8	15
380-400 (50 Hz)	3 $\phi$	3/4	3	*	5	15
416 (50 Hz)	3 $\phi$	3/4	3.1	*	5	15
460 (60 Hz)	3 $\phi$	3/4	2.8	*	5	15

\* AWG Stranded Wire Type ... size wire as per National Electrical Code or local codes.

**IMPORTANT:** Figures shown are for non-reversing models only. For reversing models contact the factory.

**IMPORTANT:** The dryer *must be* connected to the electric supply shown on the data label that is affixed to the left side panel/wall area behind the control door. In the case of 208 VAC or 240 VAC, the supply voltage *must match* the electric service specifications of the data label exactly.

**IMPORTANT:** The wire size *must be* properly sized to handle the related current.

**WARNING:** **208 VAC and 240 VAC ARE NOT THE SAME**. Any damage done to dryer components due to improper voltage connections will automatically VOID THE WARRANTY.

**NOTE:** ADC reserves the right to make changes in specifications at any time without notice or obligation.



b. Electric Models Only

<b>MLE-75 (ELECTRIC)</b>								
ELECTRICAL SERVICE SPECIFICATIONS (PER DRYER)								
<b>IMPORTANT:</b> 208 VAC and 240 VAC <b>ARE NOT THE SAME</b> . When ordering, <i>specify exact voltage</i> .								
<b>NOTES:</b> A. Fuse ratings are dual element, time delay, current limiting, class RK1 or RK5 <b>ONLY</b> . B. Circuit breakers are thermal/magnetic (industrial) motor curve type <b>ONLY</b> . For others, calculate/verify correct breaker size according to appliance amp draw rating and type of breaker used. C. Circuit breakers for 3-phase (3 $\phi$ ) dryers <b>must be</b> 3-pole type.								
APPLIED VOLTAGE/PHASE								
KW	APPROX. AMP DRAW	208/1 $\phi$ (60 Hz)	240/1 $\phi$ (60 Hz)	208/3 $\phi$ (60 Hz)	240/3 $\phi$ (50/60 Hz)	380/3 $\phi$ (50 Hz)	416/3 $\phi$ (50 Hz)	460/3 $\phi$ (60 Hz)
20		104	90	---	---	33	---	---
24		---	---	72	63	---	36	33
30		---	---	88	77	---	45	41
33		---	---	---	---	53	---	---
36		---	---	105	92	---	53	48
40		---	---	---	---	---	59	---

**IMPORTANT:** Figures shown are for non-reversing models only. For reversing models contact the factory.

**IMPORTANT:** The dryer *must be* connected to the electric supply shown on the data label that is affixed to the left side panel/wall area behind the control door. In the case of 208 VAC or 240 VAC, the supply voltage *must match* the electric service specifications of the data label exactly.

**IMPORTANT:** The wire size *must be* properly sized to handle the related current.

**WARNING:** **208 VAC and 240 VAC ARE NOT THE SAME**. Any damage done to dryer components due to improper voltage connections will automatically VOID THE WARRANTY.

**NOTE:** ADC reserves the right to make changes in specifications at any time without notice or obligation.

**IMPORTANT:** 3-phase (3 $\phi$ ) figures shown are for a 3-wire service only.

### 3. Grounding

A ground (earth) connection **must be** provided and installed in accordance with state and local codes. In the absence of these codes, grounding **must conform** to applicable requirements of the National Electrical Code ANSI/NFPA NO. 70-LATEST EDITION, or in Canada, the installation **must conform** to applicable Canada Standards: Canadian Electrical Codes Parts 1 & 2 CSA C22.1-1990 or LATEST EDITION. The ground connection may be to a proven earth ground at the location service panel.

For added personal safety, when possible, it is suggested that a separate ground wire (no. 18 minimum) be connected from the ground connection of the dryer to a grounded cold water pipe. **DO NOT ground to a gas pipe or hot water pipe.** The grounded cold water pipe **must have** metal to metal connection **ALL** the way to the electrical ground. If there are any nonmetallic interruptions, such as, a meter, pump, plastic, rubber, or other insulating connectors, they **must be** jumped out with no. 4 copper wire and securely clamped to bare metal at both ends.

**IMPORTANT:** For personal safety and proper operation, the dryer *must be* grounded.

Provisions are made for ground connection in each dryer at the electrical service connection area.

### 4. Electrical Connections

**NOTE:** A wire diagram is located in the front electrical control box for connection data.

#### a. Gas and Steam Models Only

**NOTE: A CIRCUIT SERVICING EACH DRYER MUST BE PROVIDED.**

#### 1) Single-Phase (1 $\phi$ ) Wiring Connections (Hookup)

The electrical connections on **ALL** single-phase (1 $\phi$ ) gas and steam dryers are made into the rear service box located at the upper left area of the dryer.

Actual electrical wire connections are made to the L1 and L2 terminals of the motor contactor located in the rear service box mentioned above. The ground connection is also made to the copper lug also provided in this box.

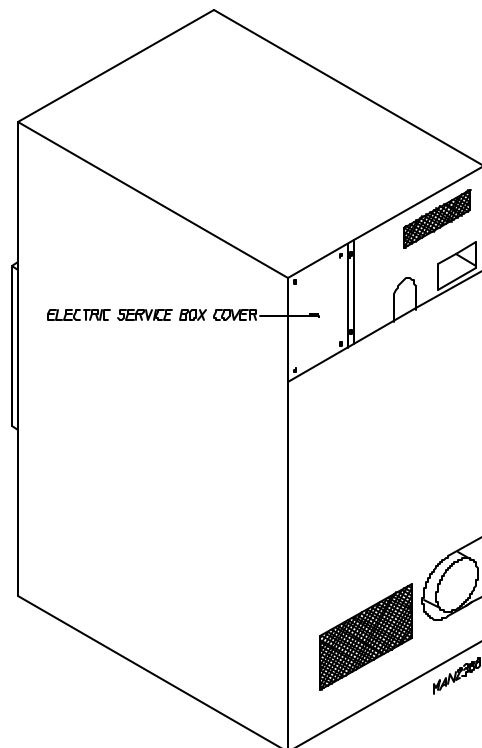

Single-Phase (1Ø) Electrical Connections Leads		
Black + Positive	White + Neutral	Green + Ground
or L2		

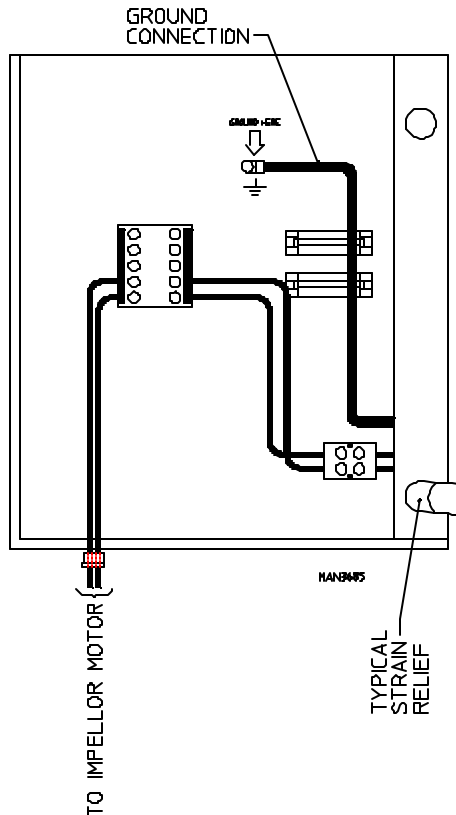

If local codes permit, power to the dryer can be made by the use of a flexible U.L. listed power cord/pigtail (wire size **must conform** to rating of dryer), or the dryer can be hard wired directly to the service breaker panel. In both cases, a strain relief **must be** installed where the wiring enters the dryer.

## 2) 3-Phase (3Ø) Wiring Connections/Hookup “Non-Reversing Models Only”

The electrical connections on **ALL** 3-phase (3Ø) gas and steam dryers are made into the rear service box located at the upper left area of the dryer. Electrical connections for electrically heated dryers are made in the electric oven area located at the upper rear area of the dryer.

**NOTE: A CIRCUIT SERVICING EACH DRYER *MUST BE* PROVIDED.**

If local codes permit, power to a gas or steam dryer can be made by the use of a flexible U.L. listed power cord/pigtail (wire size **must conform** to rating of dryer), or the dryer can be hard wired directly to the service breaker panel. In **ALL** cases, a strain relief **must be** installed where the wiring enters the dryer.

The only electrical input connections to the dryer are the 3-phase (3 $\phi$ ) power leads (L1, L2, L3, and sometimes neutral) and ground. Single-phase (1 $\phi$ ) power for the control circuit is done internally to the dryer. No single-phase (1 $\phi$ ) input connection is required on a 3-phase (3 $\phi$ ) dryer.

For gas and steam dryers manufactured for operation at 3-phase (3 $\phi$ ), the electrical connections are made at the power distribution block located in the service box at the rear, upper left corner of the dryer. The ground connection is made to the copper lug also provided in this box. To gain access to the service box contactor, the service box cover **must be** removed.

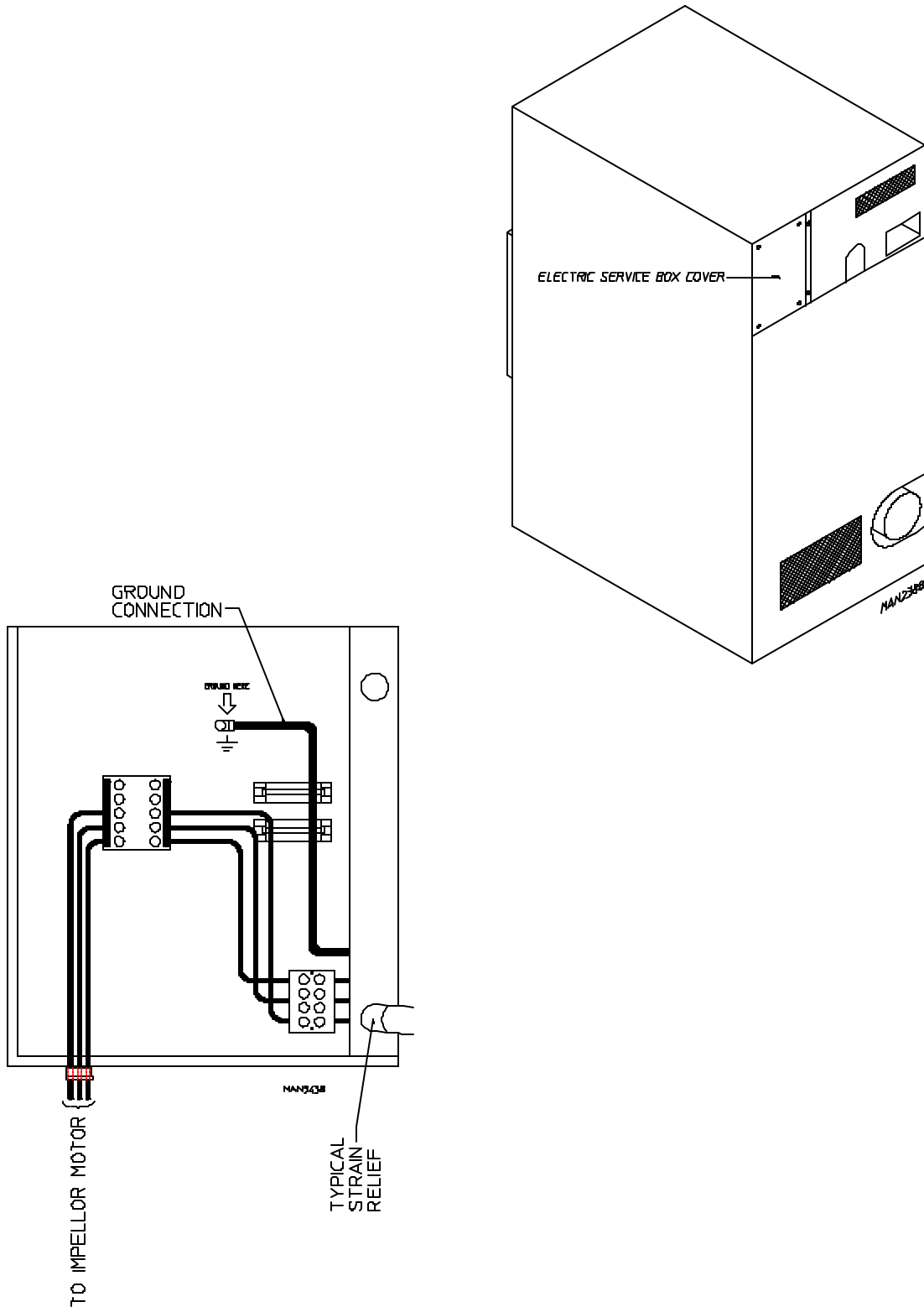

### 3) 3-Phase (3 $\phi$ ) Wiring Connections/Hookup “Reversing Models Only”

The electrical connections on **ALL** 3-phase (3 $\phi$ ) gas and steam dryers are made into the rear service box located at the upper left area of the dryer. Electrical connections for electrically heated dryers are made in the electric oven area located at the upper rear area of the dryer.

**IMPORTANT:** A separate circuit servicing each dryer *must be* provided.

If local codes permit, power to a gas or steam dryer can be made by the use of a flexible U.L. listed power cord/pigtail (wire size **must conform** to rating of dryer), or the dryer can be hard wired directly to the service breaker panel. In **ALL** cases, a strain relief **must be** installed where the wiring enters the dryer.

The only electrical input connections to the dryer are the 3-phase (3 $\phi$ ) power leads (L1, L2, L3, and sometimes neutral) and ground. Single-phase (1 $\phi$ ) power for the control circuit is done internally to the dryer. No single-phase (1 $\phi$ ) input connection is required on a 3-phase (3 $\phi$ ) dryer.

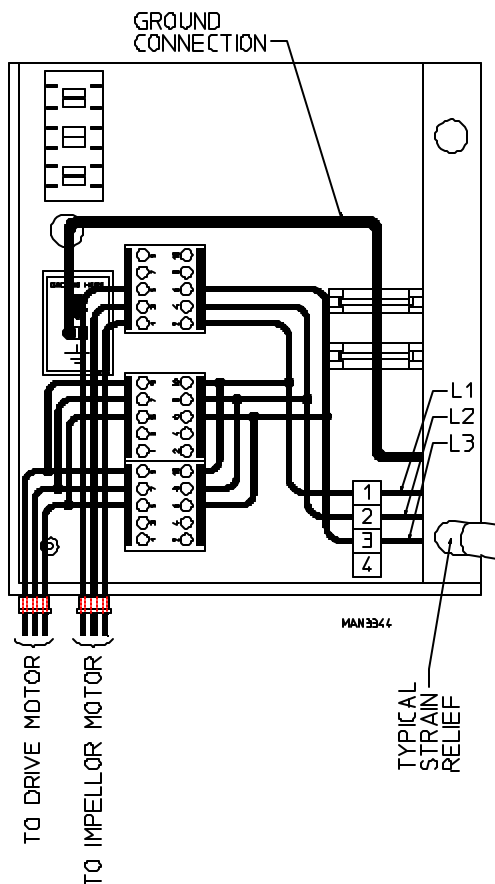
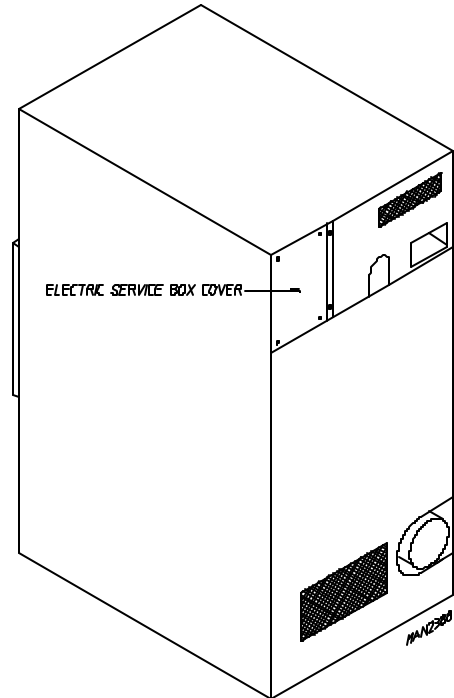

For gas and steam dryers manufactured for operation at 3-phase (3 $\phi$ ), the electrical connections are made at the power distribution block located in the service box at the rear, upper left corner of the dryer. The ground connection is made to the copper lug also provided in this box. To gain access to the service box contactor, the service box cover **must be** removed.

a) Electrically Heated Models Only

The only electrical input connections to the dryer are the 3-phase (3 $\phi$ ) power leads (L1, L2, L3, and sometimes neutral) and ground. Single-phase (1 $\phi$ ) power for the control circuit and for any single-phase (1 $\phi$ ) motors (if present) is done internally to the dryer by the factory at the oven contactor. No single-phase (1 $\phi$ ) input connection is required on a 3-phase (3 $\phi$ ) dryer.

**CAUTION:** The dryer *must be* grounded. A ground lug has been provided for this purpose.

Input connection wiring **must be** sized properly to handle the dryer's current draw. This information is printed on the dryer's data label.

**IMPORTANT:** A separate circuit servicing each dryer *must be* provided.

The electrical input connections are made at the electric oven contactor located inside the assembly at the rear center upper section of the dryer. The ground connection is made to a copper lug also provided in this area. To gain access, remove oven rear service cover.

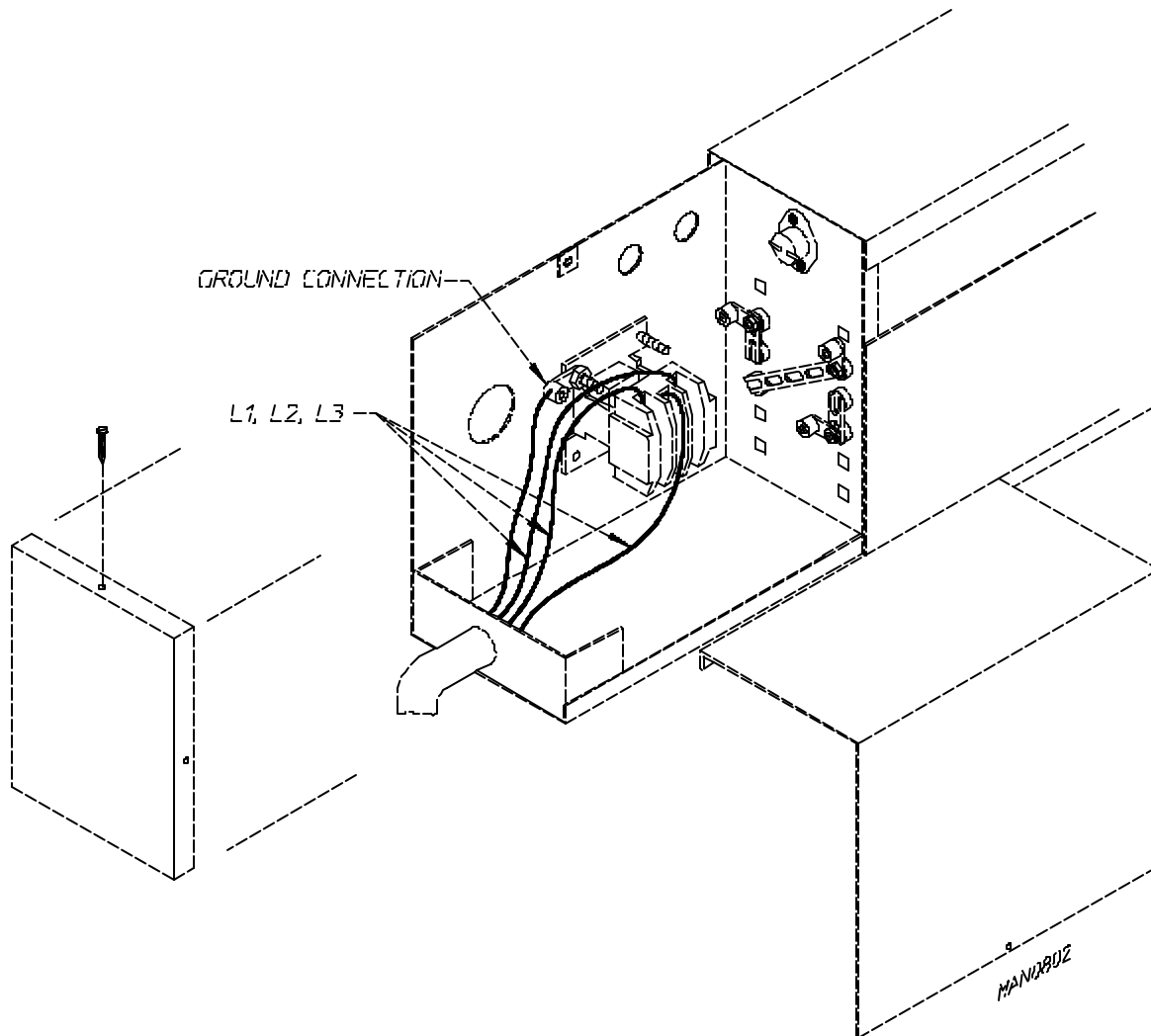

**IMPORTANT:** A strain relief *must be* used where the input wiring enters the oven assembly.

## G. GAS INFORMATION

It is your responsibility to have **ALL** plumbing connections made by a qualified professional to assure that the gas plumbing installation is adequate and conforms to local and state regulations or codes. In the absence of such codes, **ALL** plumbing connections, materials, and workmanship **must conform** to the applicable requirements of the National Fuel Gas Code ANSI Z223.1-LATEST EDITION, or in Canada, the Canadian Installation Codes CAN/CGA-B149.1-M91 (Natural Gas) or CAN/CGA-B149.2-M91 (L.P. Gas) or LATEST EDITION.

**IMPORTANT:** Failure to comply with these codes or ordinances, and/or the requirements stipulated in this manual, can result in personal injury and improper operation of the dryer.

The dryer and its individual shutoff valves **must be** disconnected from the gas supply piping system during any pressure testing of that system at test pressures in excess of 1/2 psig (3.5 kPa). The dryer **must be** isolated from the gas supply piping system by closing its individual manual shutoff valve during any pressure test of the gas supply system at test pressures equal to or less than 1/2 psig (3.5 kPa).

**IMPORTANT:** Failure to isolate or disconnect the dryer from supply as noted can cause irreparable damage to the gas valve VOIDING THE WARRANTY.

**WARNING: FIRE or EXPLOSION COULD RESULT.**

### 1. Gas Supply

The gas dryer installation **must meet** the American National Standard...National Fuel Gas Code ANSI Z223.1-LATEST EDITION, or in Canada, the Canadian Installation Codes CAN/CGA-B149.1 M91 (Natural Gas) or CAN/CGA-B149.2-M91 (L.P. Gas) or LATEST EDITION, as well as local codes and ordinances and **must be** done by a qualified professional.

**NOTE:** Undersized gas piping will result in ignition problems, slow drying, increased use of energy, and can create a safety hazard.

The dryer **must be** connected to the type of heat/gas indicated on the dryer label affixed to the left side panel/wall area behind the control door. If this information does not agree with the type of gas available, **DO NOT operate the dryer**. Contact the reseller who sold the dryer or contact the **ADC** factory.

**IMPORTANT:** Any burner changes or conversions **must be** made by a qualified professional.

The input ratings shown on the dryer data label are for elevations up to 2,000 feet (610 meters), unless elevation requirements of over 2,000 feet (610 meters) were specified at the time the dryer order was placed with the factory. The adjustment or conversion of dryers in the field for elevations over 2,000 feet (610 meters) are made by changing each burner orifice. If this conversion is necessary, contact the reseller who sold the dryer or contact the **ADC** factory.

2. Technical Gas Data

a. Gas Specifications

<b>TYPE OF GAS</b>				
NATURAL			LIQUID PROPANE	
Manifold Pressure*	3.5 inches W.C.	8.7 mb	10.5 inches W.C.	26.1 mb
In-Line Pressure	6.0 - 12.0 inches W.C.	14.92 - 29.9 mb	11.0 inches W.C.	27.4 mb

*Shaded areas are stated in metric equivalents*

\* Measured at outlet side of gas valve pressure tap when gas valve is on.

b. Gas Connections:

Inlet connection ----- 3/4-inch N.P.T.  
 Inlet supply size ----- 3/4-inch N.P.T. (minimum)  
 Btu/hr input (per dryer) --- 200,000 (50,400 kcal/hr)

1) Natural Gas

Regulation is controlled by the dryer's gas valve's internal regulator. Incoming supply pressure **must be** consistent between a minimum of 6.0 inches (14.92 mb) and a maximum of 12.0 inches (29.9 mb) water column pressure (W.C.).

2) Liquid Propane (L.P.) Gas

Dryers made for use with L.P. gas have the gas valve's internal pressure regulator blocked open so that the gas pressure **must be** regulated upstream of the dryer. The pressure measured at each gas valve pressure tap **must be** a consistent 10.5 inches (26.1 mb) water column. There is no regulator or regulation provided in an L.P. dryer. The water column pressure **must be** regulated at the source (L.P. tank) or an external regulator **must be** added to each dryer.

			<b>TYPE OF GAS</b>						L.P. Conversion Kit Part Number
MODEL NUMBER	BTU Per Hour Rating	kcal/hr Rating	Natural			Liquid Propane			
			Qty.	D.M.S.*	Part Number	Qty.	D.M.S.*	Part Number	
MLG-75	200,000	50,400	4	#29	140820	4	#47	140805	881231

*Shaded area is stated in metric equivalent*

\* Drill Material Size (D.M.S.) equivalents are as follows:

Natural Gas ..... #29 = 0.1360" (3.4544 mm).  
 Liquid Propane Gas .. #47 = 0.0785" (1.9939 mm).



### 3. Piping/Connections

**ALL** components/materials **must conform** to National Fuel Gas Code Specifications ANSI Z223.1-LATEST EDITION, or in Canada, CAN/CGA-B149.1-M91 (Natural Gas) or CAN/CGA-B149.2-M91 (L.P. Gas) or LATEST EDITION (for General Installation and Gas Plumbing), as well as local codes and ordinances and **must be** done by a qualified professional. It is important that gas pressure regulators meet applicable pressure requirements, and that gas meters be rated for the total amount of **ALL** the appliance BTUs being supplied.

The dryer is provided with a 3/4-inch N.P.T. inlet pipe connection located at the right side of the base of the dryer. The minimum pipe size (supply line) to the dryer is 3/4-inch N.P.T. For ease in servicing, the gas supply line of each dryer **must have** its own shutoff valve.

The size of the main gas supply line (header) will vary depending on the distance this line travels from the gas meter or, in the case of L.P. gas, the supply tank, other gas-operated appliances on the same line, etc. Specific information regarding supply line size **should be** determined by the gas supplier.

**NOTE:** Undersized gas supply piping can create a low or inconsistent pressure, which will result in erratic operation of the burner ignition system.

TYPICAL NATURAL GAS INSTALLATION

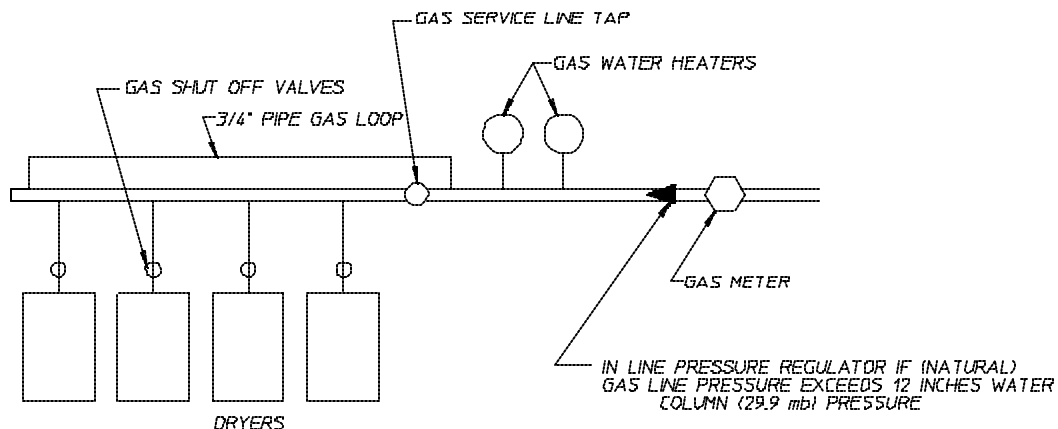

TYPICAL L.P. GAS INSTALLATION

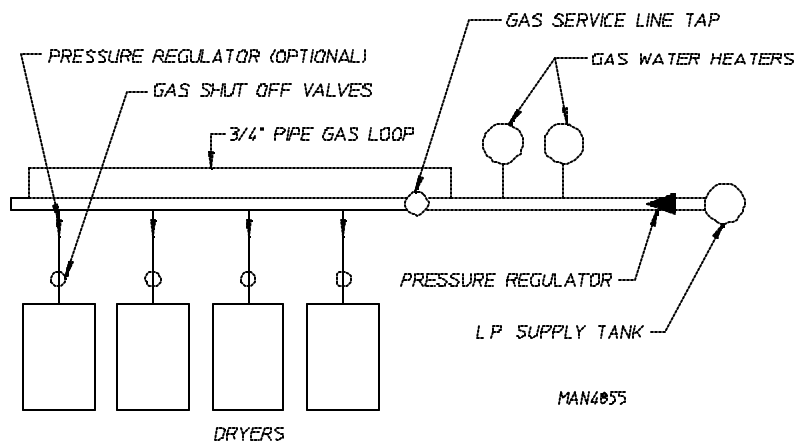

MAN4055

MS 12/27/99

Consistent gas pressure is essential at **ALL** gas connections. It is recommended that a 3/4-inch (19.05 mm) pipe gas loop be installed in the supply line servicing a bank of dryers. An in-line pressure regulator **must be** installed in the gas supply line (header) if the (natural) gas pressure exceeds 12.0 inches (29.9 mb) of water column pressure (W.C.).

**NOTE:** A water column test pressure of 3.5 inches (8.7 mb) for natural gas and 10.5 inches (26.1 mb) for liquid propane (L.P.) dryers is required at the gas valve pressure tap of each dryer for proper and safe operation.

An 1/8-inch N.P.T. plugged tap, accessible for a test gauge connection, **must be** installed in the main gas supply line immediately upstream of each dryer.

**IMPORTANT:** Pipe joint compounds that resist the action of natural gas and L.P. gas **must be** used.

**IMPORTANT:** Test **ALL** connections for leaks by brushing on a soapy water solution (liquid detergent works well).

**WARNING: NEVER TEST FOR LEAKS WITH A FLAME!!!**

**ALL** components/materials **must conform** to National Fuel Gas Code Specifications ANSI Z223.1-LATEST EDITION, or in Canada, CAN/CGA-B149.1-M91 (Natural Gas) or CAN/CGA-B149.2-M91 (L.P. Gas) or LATEST EDITION (for General Installation and Gas Plumbing), as well as local codes and ordinances and **must be** done by a qualified professional. It is important that gas pressure regulators meet applicable pressure requirements, and that gas meters be rated for the total amount of **ALL** the appliance BTUs being supplied.

**IMPORTANT:** The dryer and its individual shutoff valve **must be** disconnected from the gas supply piping system during any pressure testing of that system at test pressures in excess of 1/2 psig (3.5 kPa).

**NOTE:** The dryer **must be** isolated from the gas supply piping system by closing its individual manual shutoff valve during any pressure test of the gas supply system at test pressures equal to or less than 1/2 psig (3.5 kPa).

## H. STEAM INFORMATION

It is your responsibility to have **ALL** plumbing connections made by a qualified professional to assure that the steam plumbing installation is adequate and conforms with local and state regulations or codes.

**IMPORTANT:** Failure to comply with the requirements stipulated in this manual can result in component failure, which will VOID THE WARRANTY.

**NOTE:** The MLS-75 is manufactured with a pneumatic (piston) damper system, which requires an external supply of air 80 PSI +/- 10 PSI (5.51 bars +/- 0.69) bars.

### 1. Steam Coil PH Level

The normal PH level for copper type steam coils **must be** maintained between a value of 8.5 to 9.5. For steel type steam coils the PH level **must be** maintained between a value of 9.5 to 10.5. These limits are set to limit the acid attack of the steam coils.

**IMPORTANT:** Coil failure due to improper PH level will VOID THE WARRANTY.

## 2. Steam Requirements - High Pressure

Inlet ----- 1-inch supply line connection -- qty. one (1) at top manifold.

Return ----- 1-inch return line connection -- qty. one (1) at top manifold.

<b>OPERATING STEAM PRESSURE</b>		
MAXIMUM	125 psig	<b>862 kPa</b>
MINIMUM	100 psig*	<b>689 kPa</b>
HEAT INPUT (NORMAL LOAD)	7 Bhp	
CONSUMPTION (APPROXIMATE) @ 125 PSI	238.7 lbs/hr	<b>108.3 kg/hr</b>

*Shaded areas are stated in metric equivalents*

\* Minimum operating pressure for optimum results.

## 3. Installation Instructions

To insure an adequate supply of steam is provided, be sure that the steam lines and steam return lines are sized and laid out as stipulated in this manual. Inadequate steam lines and steam return lines or improper steam plumbing will result in poor performance and can cause component failure. Clean, dry steam **must be** provided to the dryer.

**IMPORTANT:** Steam coil failure due to water hammer by wet steam will VOID THE WARRANTY.

- a. The pressure of the condensate in the steam supply will cause water hammer and subsequent heat exchanger (steam coil) failure. The steam supply connection into the main supply line **must be** made with a minimum 10-inch (25.4 cm) riser. This will prevent any condensate from draining towards the dryer.
- b. The steam supply piping to the dryer must include a 12-inch (30.48 cm) rise along with a drip trap and check valve. This will prevent any condensate from entering the steam coil.
- c. Flexible hoses or couplings **must be** used. The dryer vibrates slightly when it runs and this will cause the steam coil connections to crack if they are hard piped to the supply and return mains.
- d. Shutoff valves for each dryer **should be** installed in the supply line, return line, and drip trap return line. This will allow the dryer to be isolated from the supply main and the return main if the dryer needs maintenance work.
- e. Install an inverted bucket steam trap and check valve at least 12-inches (30.48 cm) below the steam coil as close to the coil as possible.
  - 1) A trap with capacity of 700 pounds (317.51 kg) of condensate per hour at 125 PSI (8.62 bars) is needed for each unit.
- f. The supply line and the return line **should be** insulated. This will save energy and provide for the safety of the operator and maintenance personnel.

- g. Water pockets in the supply line, caused by low points, will provide wet steam to the coil possibly causing steam coil damage. **ALL** horizontal runs of steam supply piping **should be** pitched 1/4-inch (6.35 mm) for every 1 foot (0.31 meters) back towards the steam supply header causing the condensate in the line to drain to the header. Install a bypass trap in any low point to eliminate wet steam.

**IMPORTANT:** Flexible hose/coupling *must be* used. Coil failure due to hard plumbing connections will **VOID THE WARRANTY.**

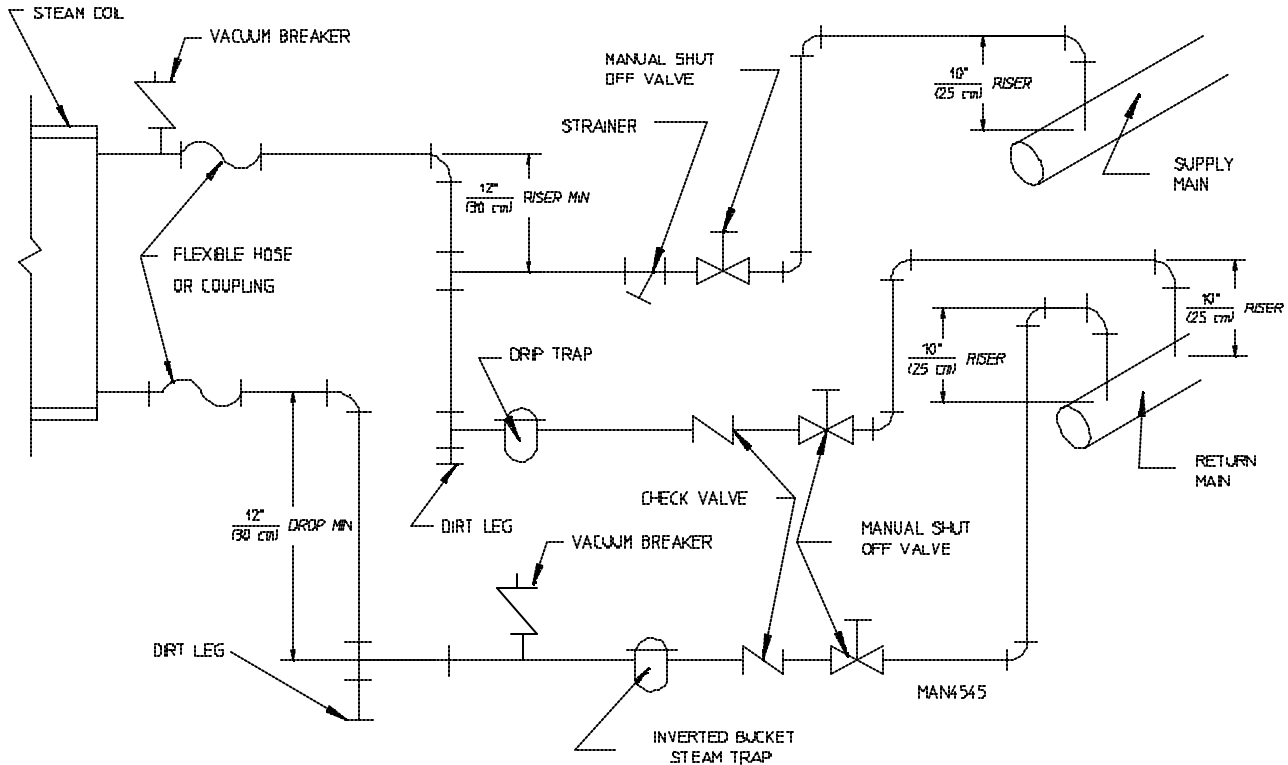

#### 4. Steam Damper Air System Connections

The MLS-75 is manufactured with a pneumatic (piston) damper system, which requires an external supply of compressed air. The air connection is made to the steam damper solenoid valve, which is located at the rear inner top area of the dryer just in front of the electric service relay box.

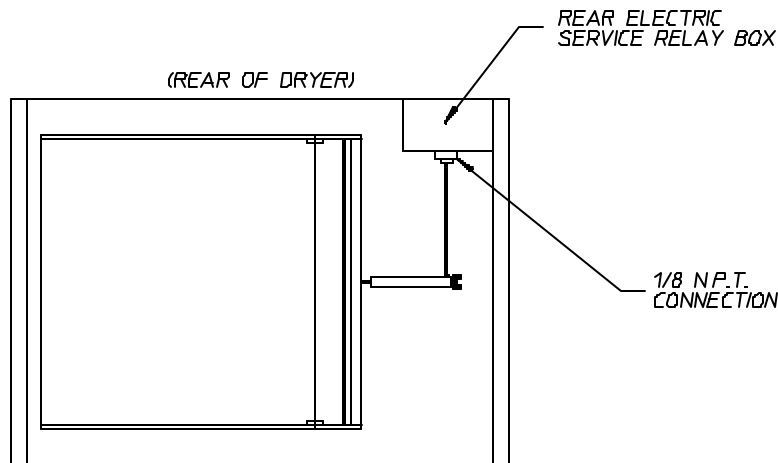

MAN2497

a. Air Requirements

COMPRESSED AIR SUPPLY	AIR PRESSURE	
Normal	80 PSI	<b>5.51 bars</b>
Minimum Supply	70 PSI	<b>4.82 bars</b>
Maximum Supply	90 PSI	<b>6.20 bars</b>

*Shaded areas are stated in metric equivalents*

b. Air Connection

Air connection to system --- 1/8-inch N.P.T.

- c. No air regulator or filtration is provided with the dryer. External regulation/filtration of 80 PSI (5.51 bars) **must be** provided. It is suggested that a filter/regulator/gauge (F/R/G) arrangement be added to the compressed air line just before the dryer connection. This is necessary to insure that correct and clean air pressure is achieved.

5. Steam Damper System Operation

The MLS-75 steam damper shown in Diagram 1 in the **illustration below**, allows the coil to stay constantly charged eliminating repeated expansion and contraction. When the damper is opened, the air immediately passes through the already hot coil, providing instant heat to start the drying process. When the damper is closed, ambient air is drawn directly into the basket (tumbler), allowing a rapid cool down (**Diagram 2**).

**Diagram 1** shows the damper in the heating (open) mode, allowing heat into the basket (tumbler).

**Diagram 2** shows the damper in the cool down (closed) mode, pulling ambient air directly into the basket (tumbler) without passing through the coils.

**NOTE:** With the dryer off or with no air supply, the steam damper is in cool down mode as shown in Diagram 2.

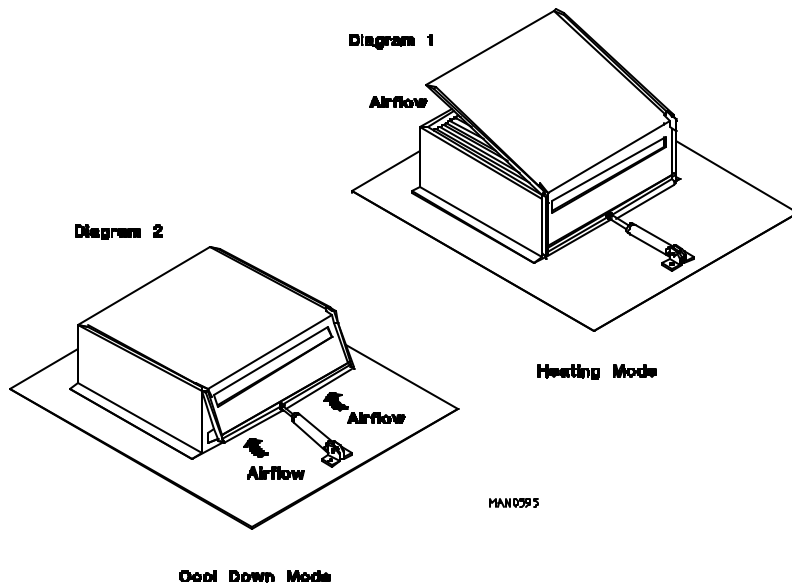

## 6. Steam Damper Air Piston (Flow Control) Operation Adjustment

Although the steam damper operation was tested and adjusted prior to shipping at 80 PSI (5.51 bars), steam damper operation **must be** checked before the dryer is put into operation. Refer to **page 33** for instructions to check steam damper system operation. If steam damper adjustment is necessary, locate the flow control valve and make the necessary adjustments as noted below.

NOTE:  
TURNING KNOB ON FLOW  
CONTROL CLOCKWISE WILL  
RESTRICT AIR FLOW TURNING  
COUNTER-CLOCKWISE WILL  
ALLOW HIGHER AIR FLOW.

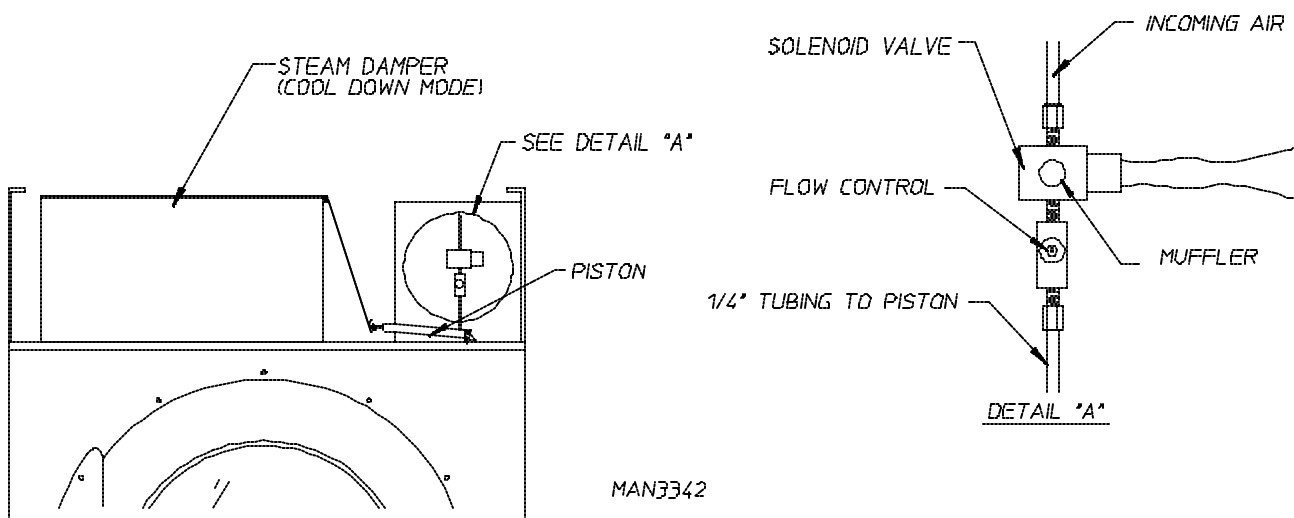

## I. PREPARATION FOR OPERATION/START-UP

The following items **should be** checked before attempting to operate the dryer:

1. Read **ALL** “CAUTION,” “WARNING,” and “DIRECTION” labels attached to the dryer.
2. Check incoming supply voltage to be sure that it is the same as indicated on the dryer data label affixed to the left side panel/wall area behind the control door. In the case of 208 VAC or 240 VAC, ***THE SUPPLY VOLTAGE MUST MATCH THE ELECTRIC SERVICE EXACTLY.***
3. **GAS MODELS** - Check to assure that the dryer is connected to the type of heat/gas indicated on the dryer data label.
4. **GAS & ELECTRIC MODELS** - The sail switch damper assembly was installed and adjusted at the factory prior to shipping. However, each sail switch adjustment **must be** checked to assure that this important safety control is functioning. (refer to Sail Switch Adjustment on **page 37**).
5. **GAS MODELS** - Be sure that **ALL** gas shutoff valves are in the open position.
6. Be sure **ALL** side and base panels are on the dryer.
7. Check **ALL** service doors to insure that they are closed and secure.
8. Be sure the lint door is securely in place.
9. Rotate the basket (tumbler/drum) by hand to be sure it moves freely.
10. Check bolts, nuts, screws, terminals, and fittings for security.
11. **STEAM MODELS** - Check to insure air supply (80 PSI [5.51 bars]) is connected to the dryers.
12. **STEAM MODELS** - Check to insure **ALL** steam shutoff valves are open.
13. **STEAM MODELS** - Check steam damper operation.
14. Check basket (tumbler) bearing setscrews to insure they are **ALL** tight.

## J. PREOPERATIONAL TESTS

**ALL** dryers are thoroughly tested and inspected before leaving the factory. However, a preoperational test **should be** performed before the dryer is publicly used. It is possible that adjustments have changed in transit or due to marginal location (installation) conditions.

1. Turn on electric power to the dryer.
  - a. Open **ALL** shutoff valves (gas models Only).
2. Refer to the Operating Instructions for starting your particular model dryer.
3. Gas Dryers
  - a. When a gas dryer is first started (during initial start-up), it has a tendency not to ignite on the first ignition attempt. This is because the gas supply piping is filled with air, so it may take a few minutes for the air to be purged from the lines.

**NOTE:** During the purging period, check to be sure that **ALL** gas shutoff valves are open.

**NOTE:** Gas dryers are equipped with a Direct Spark Ignition (DSI) system, which has internal diagnostics. If ignition **is not** established within three (3) times, the heat circuit in the DSI module will “LOCKOUT” until it is manually reset. To reset the DSI system, open and close the main door and restart the dryer.

- b. A gas pressure test **should be** taken at the gas valve pressure tap of each dryer to assure that the water column (W.C.) pressure is correct and consistent.

**NOTE:** Water column pressure requirements (measured at the pressure tap of the gas valve body):

Natural Gas----- 3.5 inches (8.7 mb) water column.

Liquid Propane (L.P.) Gas ----- 10.5 inches (26.1 mb) water column.

**IMPORTANT:** There is no regulator provided in an L.P. dryer. The water column pressure **must be** regulated at the source (L.P. tank), or an external regulator **must be** added to each dryer.

4. Steam Dryers
  - a. Check to insure that steam damper is functioning properly.
    - 1) The steam damper **should not** “slam” (open or closed) when it reaches the end of (piston) travel. Additionally, the steam damper **should not** bind and/or stop during travel. If either of these conditions occur, the flow control **must be** adjusted. Refer to the **bottom illustration** on **page 34** for steam damper air piston (flow control) operation adjustment instructions.



5. Electrically Heated Dryers
  - a. Check to insure that electric oven/contactor assembly is activating.
6. Make a complete operational check of **ALL** safety related circuits:
  - a. Door Switch(es)
  - b. Hi-Limit Thermostats
  - c. Sail Switch (for Gas and Electric Models Only)

**NOTE:** To check for proper sail switch operation (for gas and electric models only), open the main door and while holding main door switch plunger in, start dryer. Dryer should start but heat circuit ***should not be*** activated (on). If the heat system is activated, the sail switch is improperly adjusted and ***must be*** adjusted by bending the actuator arm of the sail switch toward the burner box. If the actuator arm is bent too far toward the burner box of the dryer, the dryer **may not** have heat when needed. After any adjustment to the sail switch, the above procedure ***must be*** repeated to verify proper operation of the sail switch.

7. The dryer **should be** operated through one (1) complete cycle to assure that no further adjustments are necessary and that **ALL** components are functioning properly.

### BASKET COATING

The basket (tumbler) is treated with a protective coating. We suggest dampening old garments or cloth material with a solution of water and nonflammable mild detergent and tumbling them in the basket (tumbler) to remove this coating.

8. Make a complete operational check of **ALL** operating controls.
  - a. For microprocessor model check controller (computer) programs/selections...
    - 1) Each microprocessor controller (computer) has been preprogrammed by the factory with the most commonly used parameter (program) selections. If computer program changes are required, refer to the computer programming manual which was shipped with the dryer.
9. Check the electric service phase sequence (3-phase [3 $\phi$ ] models only). While the dryer is operating, check to see if the blower wheel (impellor/fan) is rotating in the proper direction. Looking from the front, the blower wheel (impellor/fan) should spin in the clockwise (CW) direction. If it is, the phasing is correct. If the phasing is incorrect, reverse two (2) of the three (3) leads at connections L1, L2, L3 of the power supply to the dryer.

**IMPORTANT:** If the blower wheel (impellor/fan) is rotating in the wrong direction, this **will not** only drastically reduce drying efficiency, but it can also cause premature component failure.

10. Reversing Models Only - Basket (tumbler) dryer **should never be** operated with less than a 30 lb. (14 kg.) load dry weight. The size of the load will affect the coast-down and dwell (stop) times. The basket (tumbler) must come to a complete stop before starting in opposite direction.

a. Microprocessor Models

- 1) Spin and stop are not adjustable in the Automatic Mode and have been preprogrammed into the microprocessor controller (computer) for 150-seconds spin time in forward direction, 120-seconds in the reverse direction and a 5-second dwell (stop) time.
- 2) Spin and stop times are adjustable in the Manual (timed) Mode.

b. Dual Timer Models

- 1) Both dwell (stop) and basket [tumbler] spin time are adjustable. (Refer to the **illustration** on **page 48.**)

11. Check to insure that **ALL** setscrews (i.e., basket [tumbler] drive, idler, etc.) are tight.

## K. PREOPERATIONAL INSTRUCTIONS

1. To start the dryer:

a. Microprocessor controller (computer) dryers.

- 1) The light emitting diode (L.E.D.) display will read “REAdY.”
- 2) Press the “E” on the keyboard (touch pad).
- 3) The dryer will start and the display will flash “dRYING MANUAL CYCLE E” “dRY TEMP 180° F” “COOL TEMP 80° F” “30 REMAIN” “dRUM TEMP”

Refer to the User’s Manual for detailed operating instructions.

b. Dual Timer Dryers

- 1) Turn drying timer knob for a time of 20 minutes.
- 2) Select “High Temp.”
- 3) Push “Push To Start” switch.
- 4) To stop dryer, open the main door.

## L. SHUT DOWN INSTRUCTIONS

If the dryer is to be shut down (taken out of service) for a period of time, the following **must be** performed:

1. Discontinue power to the dryer either at the external disconnect switch or the circuit breaker.
2. Discontinue the heat supply:
  - a. ***GAS MODELS ... discontinue the gas supply.***
    - 1) **SHUT OFF external gas supply shutoff valve.**
    - 2) **SHUT OFF internal gas supply shutoff valve located in the gas valve burner area.**
  - b. ***STEAM MODELS ... discontinue the steam supply.***
    - 1) **SHUT OFF external (location furnished) shutoff valve.**
    - 2) **SHUT OFF internal steam valves in the supply lines and the return lines.**

# SECTION IV

## SERVICE/PARTS INFORMATION

### A. SERVICE

1. Service **must be** performed by a qualified trained technician, service agency, or gas supplier. If service is required, contact the reseller from whom the **ADC** equipment was purchased. If the reseller **cannot** be contacted or is unknown, contact the **ADC** Service Department for a reseller in your area.

**NOTE:** When contacting the **ADC** Service Department, be sure to give them the correct **model number** and **serial number** so that your inquiry is handled in an expeditious manner.

### B. PARTS

1. Replacement parts **should be** purchased from the reseller from whom the **ADC** equipment was purchased. If the reseller **cannot** be contacted or is unknown, contact the **ADC** Parts Department for a reseller in your area. Parts may also be purchased directly from the factory by calling the **ADC** Parts Department at (508) 678-9000 or you may FAX in your order at (508) 678-9447.

**NOTE:** When ordering replacement parts from the **ADC** reseller or the **ADC** factory be sure to give them the correct **model number** and **serial number** so that your parts order can be processed in an expeditious manner.

# SECTION V

## WARRANTY INFORMATION

### A. RETURNING WARRANTY CARD(S)

1. Before any dryer leaves the **ADC** factory test area, a warranty card is placed on the back side of the main door glass. These warranty cards are intended to serve the customer where we record the individual installation date and warranty information to better serve you, if you file a warranty claim.
  - a. If a warranty card did not come with your dryer, contact the **ADC** Warranty Department or the **ADC** Service Department at (508) 678-9000.

**IMPORTANT:** A separate warranty card *must be* completed and returned for each individual dryer.

**NOTE:** Be sure to include the installation date when returning the warranty card(s).

### B. WARRANTY

For a copy of the **ADC** commercial warranty covering your particular dryer(s), contact the **ADC** reseller from whom you purchased the equipment and request a dryer warranty form. If the reseller **cannot** be contacted or is unknown, warranty information can be obtained from the factory by contacting the **ADC** Warranty Department at (508) 678-9000.

**NOTE:** Whenever contacting the **ADC** factory for warranty information, be sure to have the dryer's **model number** and **serial number** available so that your inquiry can be handled in an expeditious manner.

### C. RETURNING WARRANTY PART(S)

**ALL** dryer or parts warranty claims or inquiries **should be** addressed to the **ADC** Warranty Parts Department. To expedite processing, the following procedures **must be** followed:

1. No parts are to be returned to **ADC** without prior written authorization ("Return Material Authorization" [R.M.A.]) from the factory.

**NOTE:** An R.M.A. is valid for only thirty (30) days from date of issue.

- a. The R.M.A. issued by the factory, as well as any other correspondence pertaining to the returned part(s), **must be** included inside the package with the failed merchandise.

2. Each part **must be** tagged with the following information:
  - a. **Model number** and **serial number** of the dryer from which part was removed.
  - b. Nature of failure (be specific).
  - c. Date of dryer installation.
  - d. Date of part failure.
  - e. Specify whether the part(s) being returned is for a replacement, a credit, or a refund.

**NOTE:** If a part is marked for a credit or a refund, the invoice number covering the purchase of the replacement part **must be** provided.

**NOTE:** Warranty tags (ADC Part No. 450064) are available at “no charge” from ADC upon request.

3. The company returning the part(s) must clearly note the complete company name and address on the outside of the package.
4. **ALL** returns **must be** properly packaged to insure that they are not damaged in transit. *Damage claims are the responsibility of the shipper.*

**IMPORTANT:** No replacements, credits, or refunds **will be** issued for merchandise damaged in transit

5. **ALL** returns **should be** shipped to the ADC factory in such a manner that they are insured and a proof of delivery can be obtained by the sender.
6. **Shipping charges are not the responsibility of ADC. ALL returns should be “prepaid” to the factory. Any “C.O.D.” or “COLLECT” returns will not be accepted.**

**IMPORTANT:** No replacements, credits, or refunds **will be** issued if the claim **cannot** be processed due to insufficient information. The party filing the claim **will be** notified in writing, either by “FAX” or “CERTIFIED MAIL - Return Receipt Requested,” as to the information necessary to process claim. If a reply **is not** received by the ADC Warranty Department within thirty (30) days from the FAX/letter date, then no replacements, credits, or refunds **will be** issued, and the merchandise **will be** discarded.

# SECTION VI

## ROUTINE MAINTENANCE

### A. CLEANING

A program and/or schedule **should be** established for periodic inspection, cleaning, and removal of lint from various areas of the dryer, as well as throughout the ductwork system. The frequency of cleaning can best be determined from experience at each location. Maximum operating efficiency is dependent upon proper air circulation. The accumulation of lint can restrict this airflow. If the guidelines in this section are met, an ADC dryer will provide many years of efficient, trouble free, and most importantly, safe operation.

**WARNING: LINT FROM MOST FABRICS IS HIGHLY COMBUSTIBLE. THE ACCUMULATION OF LINT CAN CREATE A POTENTIAL FIRE HAZARD.**

**WARNING: KEEP DRYER AREA CLEAR and FREE FROM COMBUSTIBLE MATERIALS, GASOLINE, and OTHER FLAMMABLE VAPORS and LIQUIDS.**

**NOTE:** Suggested time intervals shown are for average usage which is considered six (6) to eight (8) operational (running) hours per day.

**IMPORTANT:** Dryer produces combustible lint and must be exhausted to the outdoors. Every 6 months, inspect the exhaust ducting and remove any lint build up.

### SUGGESTED CLEANING SCHEDULE

#### ***EVERY THIRD or FOURTH LOAD***

Clean the lint screen every third or fourth load. A clogged lint screen will cause poor dryer performance. The lint screen is located behind the lint door in the base of the dryer. Open the lint door, brush the lint off the lint screen, and remove the lint. Inspect lint screen and replace if torn.

**NOTE:** The frequency of cleaning the lint screen can best be determined from experience at each location.

#### ***WEEKLY***

Clean lint accumulation from lint chamber, thermostat, and microprocessor temperature sensor (sensor bracket) area.

**WARNING: TO AVOID THE HAZARD OF ELECTRICAL SHOCK, DISCONTINUE ELECTRICAL SUPPLY TO THE DRYER.**

#### ***STEAM DRYERS***

Clean the steam coil fins. We suggest using compressed air and a vacuum cleaner with brush attachment.

**WARNING:** When cleaning steam coil fins, be careful not to bend the fins. If fins are bent, straighten by using a fin comb which is available from local air conditioning supply houses.

**90 DAYS**

1. Remove lint from around basket (tumbler), drive motors, and surrounding areas.
2. Remove lint from gas valve burner area with a dusting brush or vacuum cleaner attachment.
3. Clean any lint accumulation in and around both the blower and drive motor casing openings.

**NOTE:** To prevent damage, avoid cleaning and/or touching ignitor/flame-probe assembly.

**EVERY 6 MONTHS**

Inspect and remove lint accumulation in customer furnished exhaust ductwork system and from dryer's internal exhaust ducting.

**NOTE: THE ACCUMULATION OF LINT IN THE EXHAUST DUCTWORK CAN CREATE A POTENTIAL FIRE HAZARD.**

**NOTE: DO NOT** OBSTRUCT THE FLOW OF COMBUSTION and VENTILATION AIR. CHECK CUSTOMER FURNISHED BACK DRAFT DAMPERS IN THE EXHAUST DUCTWORK. INSPECT and REMOVE ANY LINT ACCUMULATION, WHICH CAN CAUSE THE DAMPER TO BIND or STICK.

**NOTE:** A back draft damper that is sticking partially closed can result in slow drying and shutdown of heat circuit safety switches or thermostats.

**NOTE:** When cleaning the dryer cabinet(s), avoid using harsh abrasives. A product intended for the cleaning of appliances is recommended.



## B. ADJUSTMENTS

### *7 DAYS AFTER INSTALLATION and EVERY 6 MONTHS THEREAFTER*

Inspect bolts, nuts, screws, (bearing setscrews), and non-permanent gas connections (unions, shutoff valves, orifices, and grounding connections). Motor and drive belts **should be** examined. Cracked or seriously frayed belts **should be** replaced. Tighten loose V-belts when necessary. Complete operational check of controls and valves. Complete operational check of **ALL** safety devices (door switches, lint drawer switch, sail switch, burner and hi-limit thermostats).

## C. LUBRICATION

The motor bearings, idler bearings .. and under normal/most conditions the basket (tumbler) bearings are permanently lubricated. It is physically possible to relubricate the basket (tumbler) bearings if you choose to do so even though this practice is not necessary. Use Shell Alvania #2 grease or its equivalent. The basket (tumbler) bearings used in the dryer **DO NOT** have a grease fitting. Provisions are made in the bearing housing for the addition of a grease fitting which can be obtained elsewhere, or from **ADC** by ordering kit P/N 882159 (includes two [2] fittings).

# SECTION VII

## PROCEDURE FOR FUNCTIONAL CHECK OF REPLACEMENT COMPONENTS

### 1. Microprocessor Controller (Computer) Board

- a. Upon completing installation of the replacement microprocessor controller (computer) board, reestablish power to the dryer.
- b. Start the drying cycle by pressing any of the preset cycles in letters A-F.

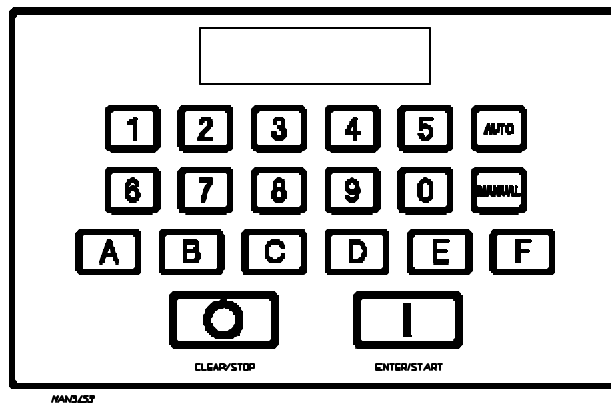

- c. Verify that the motor(s) and the heat indicator dots, in the microprocessor controller (computer) L.E.D. display are on. (Refer to the **illustration below.**)

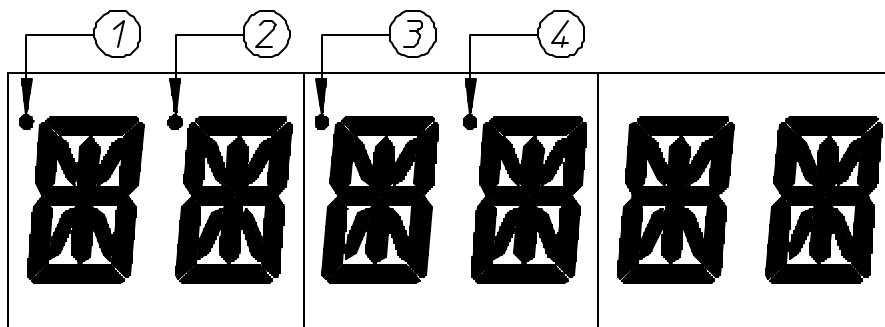

- 1) Basket (tumbler) in Forward Mode (clockwise [CW])
- 2) Basket (tumbler) in Reverse Mode (counterclockwise [CCW]) indicator (for reversing models Only)
- 3) Heat on indicator
- 4) On indicator (dryer is in operation mode)

- d. Verify that the motor(s) heat and door indicator lights, on the back side of the microprocessor controller (computer) board are lit. (Refer to the **illustration below**).

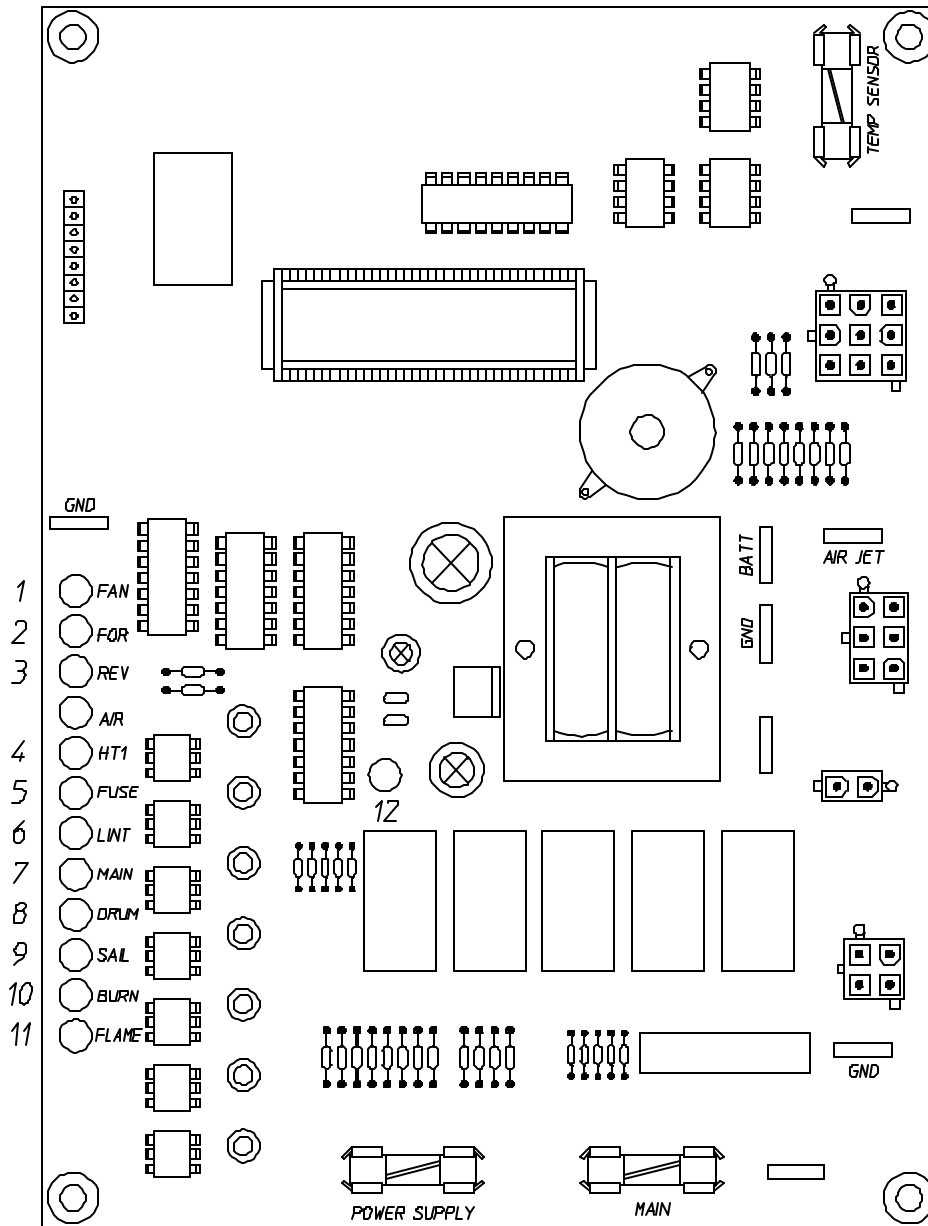

MAN3530

- 1) "FAN" (Blower) light emitting diode (L.E.D.) indicator
- 2) "FOR" (Forward) output L.E.D. indicator (for optional reversing models Only)
- 3) "Rev" (Reverse) output L.E.D. indicator (for optional reversing models Only)
- 4) "HT1" (Heat) output L.E.D. indicator
- 5) "Fuse" (Main Fuse) input L.E.D. indicator
- 6) "Lint" (Lint Door) input L.E.D. indicator
- 7) "Main" (Main Door) input L.E.D. indicator
- 8) "Drum" (Basket [Tumbler] Hi-Limit) input L.E.D. indicator
- 9) "Sail" (Sail Switch) input L.E.D. indicator
- 10) "Burn" (Burner Hi-Limit) input L.E.D. indicator
- 11) "Flame" (Burner Control Failure) input L.E.D. indicator
- 12) "Power Supply" L.E.D. input indicator

- e. Open main door. The dryer **must stop** and **ALL** output indicator lights on the back side of the microprocessor controller (computer) board **must go out**. (Refer to the **illustration** on the previous page.)
  - f. Try to restart the dryer with the main door open.
  - g. The microprocessor controller (computer) board's light emitting diode (L.E.D.) display must read "**DOOR.**"
  - h. Close the main door and restart the dryer.
  - i. Functional check of microprocessor controller (computer) board is complete.
2. For models with Johnson Controls Direct Spark Ignition (DSI) Module (G760)

Theory Of Operation:

Start the drying cycle. When the gas burner ignites within the chosen trial for ignition time (6-seconds), the flame sensor detects gas burner flame and signals the DSI module to keep the gas valve open...as long as there is a call for heat. The DSI module will "LOCKOUT" if the gas burner flame is not sensed at the end of the trial for ignition period. The trial for ignition period will be repeated for a total of three (3) retries/trials (the initial try and two [2] more retries/trials). If the flame is not sensed at the end of the third retry/trial (inter-purge period of 30-seconds) the DSI module will "LOCKOUT" (L.E.D. flashes).

A steady L.E.D. indicator indicates normal operation.

No L.E.D. indicator indicates a power or an internal failure has occurred.

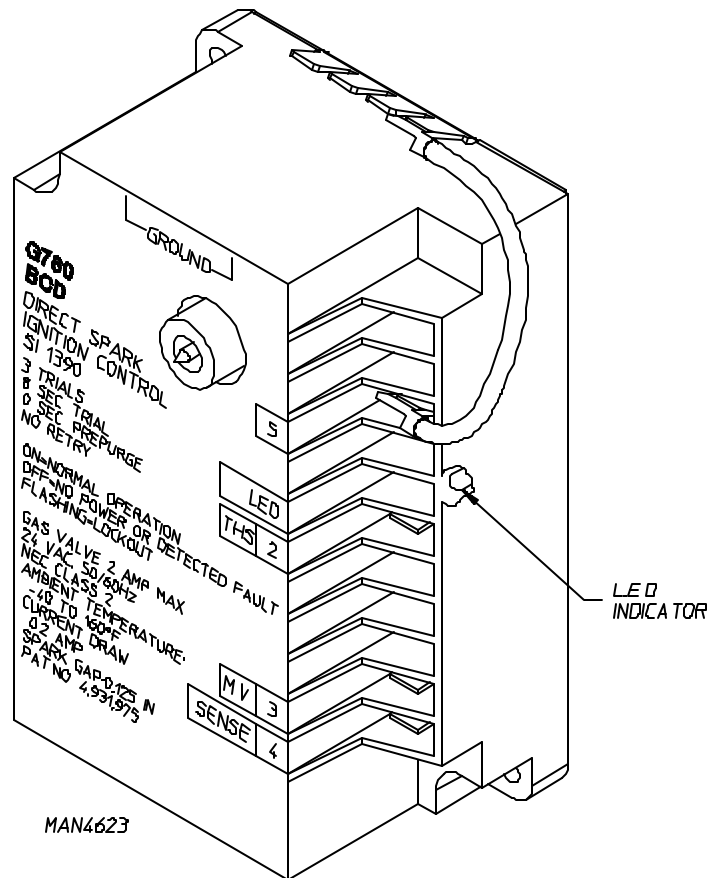

# SECTION VIII

## REVERSING TIMER SPIN/DWELL ADJUSTMENTS

Dual timer models with “reversing option” have an electric reversing timer in the electric service box, which is located in the upper rear area of the dryer.

Both the dwell (stop) time and basket (tumbler) spin time are adjustable by mode selection switches located on the electronic timer (as noted in the **illustration below**).

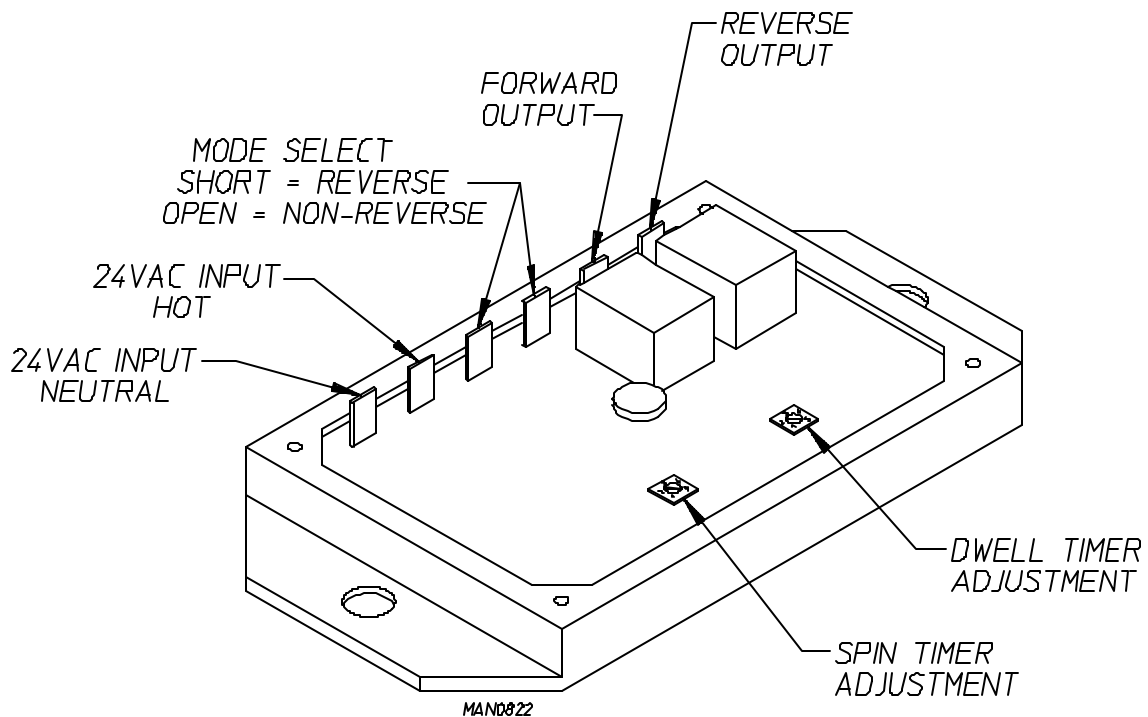

<b>TIMING LEGEND</b>					
<b>SPIN TIME</b>					
Adjustment Position Number	1	2	3	4	5
Time in Seconds*	30	60	90	120	150
<b>DWELL (Stop) TIME</b>					
Adjustment Position Number	1	2	3	4	5
Time in Seconds*	5	6.3	7.6	8.9	10.2
* Values shown are +/- 1 second.					



# THE DATA LABEL

## 1. MODEL NUMBER

The model number is an **ADC** number, which describes the size of the dryer and the type of heat (gas, electric, or steam).

## 2. SERIAL NUMBER

The serial number allows **ADC** to gather information on your particular dryer.

## 3. MANUFACTURING CODE NUMBER

The manufacturing code number is a number issued by **ADC** which describes **ALL** possible options on your particular model.

## 4. TYPE OF HEAT

This describes the type of heat for your particular dryer, gas (either natural gas or liquid propane [L.P.] gas) or steam.

## 5. HEAT INPUT (for GAS DRYERS)

This describes the heat input in British Thermal Units per Hour (BTUH).

## 6. ORIFICE SIZE (for GAS DRYERS)

Gives the number drill size used.

## 7. ELECTRIC SERVICE

This describes the electric service for your particular model.

## 8. GAS MANIFOLD PRESSURE (for GAS DRYERS)

This describes the manifold pressure taken at the gas valve tap.

## 9. APPLICABLE APPROVAL SEAL(S)

I.e., Canadian Standards Association International.

# SECTION X

## BURNER and BASKET (TUMBLER)/LINT CHAMBER MANUAL RESET HI-LIMIT INSTRUCTIONS

### IMPORTANT

#### MANUAL RESET HI-LIMIT INSTRUCTIONS

FOR PHASE 6 MODELS  
(GAS MODELS ONLY)

This dryer was manufactured with a burner manual reset hi-limit and basket (tumbler)/lint chamber hi-limit thermostat which is monitored by the Phase 6 computer. If either manual reset thermostat is open prior to start of the drying cycle, the dryer will start momentarily and then shut down, the Phase 6 computer will display an error code with an audio indication. If the basket (tumbler)/lint chamber hi-limit thermostat is open, the display will read “dRUM SAFETY FAIL.” If the burner hi-limit thermostat is open, the display will read “bURNER SAFETY FAIL.”

If either manual reset hi-limit thermostat opens during a drying cycle, the display will show the applicable error code described above along with an audio indication. If the drum temperature is above 100° F (38° C), the dryer will continue to run with no heat for 3 minutes or until the drum temperature has flattened below 100° F (38° C). The “STOP/CLEAR” button on the Phase 6 keyboard (touch pad) **must be** pressed to clear the error condition. The open manual reset hi-limit thermostat **must be** reset “manually” prior to the start of the next cycle.

This hi-temperature condition may be caused due to a restricted exhaust, poor airflow, or improper burner operation.

The location of the burner hi-limit is on the right side of the burner box and the basket (tumbler) hi-limit is located in the lint chamber area.

**WARNING:** Discontinue power to dryer before attempting to reset hi-limit.

### IMPORTANT

This dryer is equipped with a burner hi-limit and tumbler/lint chamber hi-limit thermostat which **must be** reset manually.

**WARNING:** Discontinue power to dryer before attempting to reset hi-limit.

ADC P/N: 114093



# **IMPORTANT**

## **MANUAL RESET HI-LIMIT INSTRUCTIONS**

FOR PHASE 6 MODELS

(ELECTRIC OR STEAM MODELS ONLY)

This dryer was manufactured with a manual reset basket (tumbler)/lint chamber hi-limit thermostat which is monitored by the Phase 6 computer. If the manual reset thermostat is open prior to start of the drying cycle, the dryer will start momentarily and then shut down, displaying “dRUM SAFETY FAIL” with an audio indication.

If the manual reset hi-limit thermostat opens during a drying cycle, the display will read “dRUM SAFETY FAIL” with an audio indication. If the drum temperature is above 100° F (38° C), the dryer will continue to run with no heat for 3 minutes or until the drum temperature has flattened below 100° F (38° C). The “STOP/CLEAR” button on the Phase 6 keyboard (touch pad) **must be** pressed to clear this “dRUM SAFETY FAIL” condition. The open manual reset hi-limit thermostat **must be** reset “manually” prior to the start of the next cycle.

This hi-temperature condition may be caused due to a restricted exhaust, poor airflow, or improper burner operation.

The basket (tumbler) manual reset hi-limit is locked in the chamber area.

**WARNING:** Discontinue power to dryer before attempting to reset hi-limit.

## **IMPORTANT**

This dryer is equipped with a lint chamber hi-limit thermostat which must be reset manually.

**WARNING:** Discontinue power to dryer before attempting to reset hi-limit.

ADC P/N: 114501

ADC 113122    1- 12/29/99-25    2- 01/04/00-100    3- 02/25/00-100  
4- 05/09/00-250    5\* 11/08/00-100    6\* 03/20/01-100  
7\* 06/14/01-100



## Free Manuals Download Website

<http://myh66.com>

<http://usermanuals.us>

<http://www.somanuals.com>

<http://www.4manuals.cc>

<http://www.manual-lib.com>

<http://www.404manual.com>

<http://www.luxmanual.com>

<http://aubethermostatmanual.com>

Golf course search by state

<http://golfingnear.com>

Email search by domain

<http://emailbydomain.com>

Auto manuals search

<http://auto.somanuals.com>

TV manuals search

<http://tv.somanuals.com>