

Mobile Refrigerated Cart

Double Compartment

Model:

1000-MR2



- **INSTALLATION**
- **OPERATION**
- **MAINTENANCE**



W164 N9221 Water Street • P.O. Box 450 • Menomonee Falls, Wisconsin 53052-0450 USA
PHONE: 262.251.3800 • 800.558.8744 USA/CANADA FAX: 262.251.7067 • 800.329.8744 U.S.A. ONLY
www.alto-shaam.com

Alto-Shaam Mobile Refrigerated Carts

1.0 INTRODUCTION

This technical manual provides information on the installation, operation, maintenance and inspection of this unit. A complete parts breakdown is provided.

EQUIPMENT DESCRIPTION

The unit consist of the following:

Storage compartment : The insulated food storage compartment is clear storage area Included in this area are the adjustable shelves and cooling coil.

Doors: Access to the storage compartment is through a hinged-mounted insulated door.

Condensing unit Compartment : This area contains the condensing unit along with the necessary controls.

Evaporator Coil : The evaporator coil is located in the storage compartment and is responsible for distributing the cold air associated with the refrigeration system

1.2 EQUIPMENT SUPPLIED

The unit is shipped from the factory fully assembled except the adjustable shelving that will require positioning on the side racks. The complete assembly is palletized and crated to reduce the possibility of damage in shipping and storage.

1.3 LEADING PARTICULARS

Refrigerant: 404a

Electrical :

1000-MR-2

220-240VAC

50 Hz, 1Ø

3.76 Amps



NEMA 6-15P

15A, 250V Plug

Net 557±22 lb (253±10kg)

Shipping 693±22 lb (315±10kg)

2.0 FUNCTIONAL DESCRIPTION

This unit is self-contained, automatically controlled, continuous duty perishable food storage system. It is designed with the intent and purpose of storing cold food items. The operating temperature is automatically monitored by controls that are factory-set to maintain a predetermined, adequate condition.

The unit consists of two basic compartment assemblies:

- a) *Condensing Unit Compartment* which includes the condensing unit, the electrical control panel with power switch and terminal box, and a heated condensation evaporator.
- b) *Storage Compartment* which consists of the insulated clear storage area for perishable food items requiring a temperature range of 37° to 40°F (3° to 4°C). The clear storage area includes adjustable shelving.

2.1 SYSTEM OPERATION

The primary focus for the design of the refrigerated cabinet is for the safe storage of food products which require refrigeration. Considerable engineering attention was placed on the qualities of function and serviceability.

The refrigeration system is a closed loop system. Unless the system develops a leak, adding additional refrigerant is not necessary.

3.0 START UP PROCEDURE

The refrigeration system is completely factory-assembled, pre-charged and ready for operation. The control has been set to display temperature in degrees Fahrenheit or degree Celsius as specified on the original order.

To energize the system, it is only necessary to locate the power supply cord and connect it to a proper electrical supply source. Once the supply cord has been connected to a power source, the unit can be started by switching the power control switch to the "ON" position.

3.1 SHUT-DOWN PROCEDURE

To shut-down, place the power control in the "OFF" position and open the door to allow the cabinet interior temperature to equalize with the room temperature.

Use a mild detergent diluted in warm water to wash the interior and exterior surfaces of the cabinet.

Procedures

CONTROL AND INDICATION		
NAME	TYPE	FUNCTION
Thermostat	Contact Points	Cycles the refrigeration system(automatic)
Power Control Switch(ON/OFF)	Contact Points	Terminates power to the unit
LCD display		Indicates continuous cabinet temperature

START-UP PROCEDURE	
OPERATION	RESULTS
<p>Activate system by electrical service cord into electrical supply source Turn power switch to the "ON" position</p> <p>With the door closed and the storage area empty of product, wait for a period of 1 hour</p> <p>Verify correct operating temperature. Begin stocking the containment area when the proper operating temperature has been reached.</p>	<p>The compressor should immediately come on-line and the evaporator fan activate</p> <p>The temperature in the storage area will begin to decrease</p> <p>Cabinet will have reached the proper operating temperature of 36°F ± 3°F(2°C ± 1°C)</p>

3.3 EXTENDED PERIOD OF INACTIVITY

This unit is designed for continued use at automatically cycled intervals. In case of an extended shut-down, the food storage compartment must be cleaned and wiped dry to minimize the potential of odor build-up during shutdown.

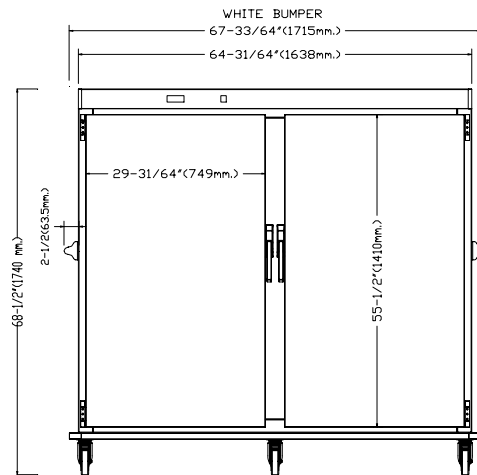
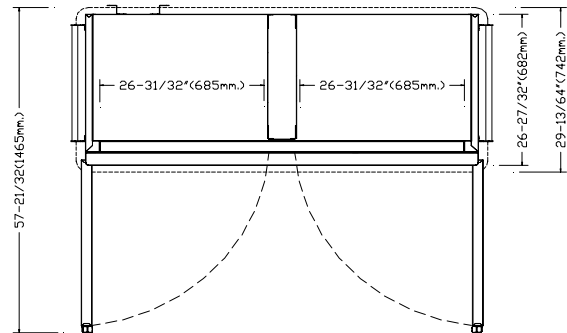
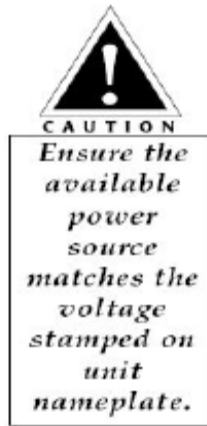

1000-MR2

4.0 OPERATING PROCEDURES

The purpose of this mobile refrigerator is to maintain cold foods at proper serving temperatures. The unit should be used for the intended purpose only.

- a) Adjust the position of the shelves to accommodate required storage needs.
- b) Switch the power to the "ON" position
- c) Pre-chill the cabinet to the full, factory preset temperature of 36°F ± 3°F (2°C)
- d) Load the refrigerator with chilled foods only. Before loading, use a food thermometer to make certain all products are at a temperature of 41°F (5°C) maximum or less. Cover foods to reduce moisture build-up on the inside wall of the cabinet. To maintain the proper refrigerated food temperature, open the door only when necessary. The mobile refrigerated door may be locked if required.

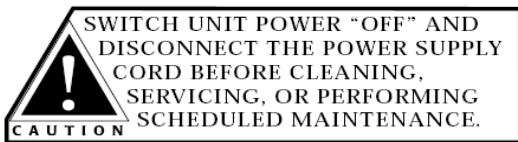

5.0 CLEANING and MAINTENANCE

A thorough, periodic maintenance schedule is required to ensure the longest and most trouble free operation. Maintenance schedules should be aimed at maximizing the efficient use of maintenance personnel, reducing down-time, and providing the orderly acquisition of spare parts support.

5.1 CLEANING

Follow appropriate state and local health (hygiene) regulations regarding all applicable cleaning and sanitation requirements for food service equipment.



DAILY

Wipe all spills at once.

WEEKLY

- a) Remove the wire shelves and side rack shelf supports. Clean these items separately using a mild, non-abrasive detergent and soft cloth.
- b) With a mild, non-abrasive detergent and water, use a soft cloth to wipe the interior liner of the storage compartment. Begin at the top and work down. Wipe the gasket surrounding the storage compartment opening.
- c) Using a mild detergent and water, wipe the vinyl door gasket. Make certain to wipe under the gasket to remove any mildew or residue.
- d) Wipe interior surfaces with a clean cloth and sanitizing solution for use on metal and vinyl food contact surfaces. This is an important step to control the build-up of unwanted mildew and mold on the evaporator coil and fan.
- e) Vacuum right, left and back panel grill vents to maintain maximum air flow.
- f) Wipe the interior of the unit with a mild detergent and water. Always wipe with the grain of the stainless steel to prevent scratching the finish.

SCHEDULED MAINTENANCE

6.0 MAINTENANCE

Remember to de-energize the unit by switching the toggle switch located on the control panel to the "OFF" position.
Disconnect the unit from the power source.

6.1 MONTHLY INSPECTION & SERVICE

CHECK THE INLET AND OUTLET ENDS OF THE DRAIN LINE to make certain there are no obstructions. If an obstruction is found :

Use compressed air to unblock an obstructed drain line in a forced air evaporator model. Remove the drain line at the evaporator coil and attach an air line using 60 pounds of pressure. *The use of chemicals to clear a clogged drain is not recommended.*

6.2 YEARLY INSPECTION & SERVICE

- 1 INSPECT THE DOOR GASKET for cracks, splits and dryness.
- 2 INSPECT THE MOVING PARTS OF THE DOOR LATCH assembly for signs of wear. Check the screw tightness on both latch and strike.
- 3 CHECK THE HINGES by opening the door to a 90-degree angle to the cabinet. With minimum pressure, lift up on the outer edge of the door. Replace the hinges if there is an upward movement of 1/2 inch (12.7mm) or more.

6.3 THERMOSTAT ADJUSTMENT

Before making any adjustment to the thermostat check the door gasket for proper seal. Proper adjustment can be tested by pulling a dollar bill through the gasket seal and feeling a slight resistance. If it is determined a proper seal is maintained around the full perimeter of the gasket, a thermostat adjustment may be necessary.

- 1 Access the 'machine status' menu by pressing and quickly releasing the "SET" key. The label of the "SET" folder appears
- 2 To display the setpoint value, press the "SET" key again. The value appears on the display
- 3 To change the setpoint value, use the "UP" and "DOWN" key within 15 seconds.

6.4 CONDENSER FAN & MOTOR REPLACEMENT

- 1 Disconnect all electrical power to the unit,
- 2 Remove the ventilation grill.
- 3 Remove the mounting bolts on the condensing unit base and slide the refrigeration assembly out
- 4 Remove the protective shroud from around the motor.
- 5 Remove the mounting screws at the motor base.
- 6 Using an allen wrench, loosen the set screw on the blade hub and slide blade from the shaft.
- 7 Install the new condenser fan by reversing the process.
- 8 Install the motor by reversing the process.

SCHEDULED MAINTENANCE

6.6 DOOR HANDLE REPLACEMENT

NOTE : It may be necessary to remove the handle assembly in order to get the cabinet through a door opening.

- 1 Remove the three side mounting screws in latch.
- 2 Remove two screws in strike
- 3 Replace in reverse order

6.7 DOOR GASKET REPLACEMENT

NOTE : It is suggested that the door be removed from the cabinet and placed face down on a work table.

- 1 Remove the fasteners and pull old gasket from the retainer.
- 2 Clean gasket retainer and immediate area.
- 3 Start new gasket into retainer. After gasket is positioned, replace fasteners.

NOTE : Avoid cutting the gasket if possible.

6.8 DOOR HINGE REPLACEMENT

NOTE : This procedure will require two people. One person to hold the door while the other removes the attachment screws.

- 1 Using a screwdriver, remove the three screws which attach the butt section of the hinges to the cabinet.
- 2 With the door detached from the cabinet, remove the screws which attach the second part of the hinge to the door.
- 3 To install the replacement hinge, reverse the process.

6.9 POWER SWITCH REPLACEMENT

- 1 Disconnect the unit from the power source
- 2 Remove the silicone seal around the perimeter of the front control leader panel. Remove the panel by lifting straight up.
- 3 Using a flat blade screwdriver remove the cover plate with switch attached.
- 4 Remove the wires connected to the switch.
- 5 Unscrew the lock washer and remove the switch.
- 6 Reverse the process to install the new switch
- 7 Remount the panel and reseal the silicone.

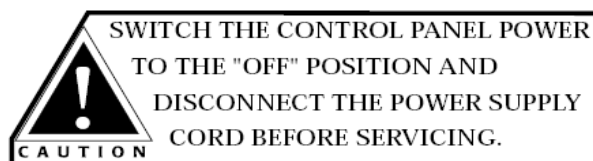

CORRECTIVE MAINTENANCE TROUBLE SHOOTING GUIDE

SYMPTOM	POSSIBLE FAILURE	REMEDY
Unit does not cool.	Bad connection at supply cord. Ill-fitting gasket. Low refrigerant.	Check supply cord at outlet. Tighen strike on door latch. Check system for leaks and recharge.
Unit does not operate.	Control failure. Incorrect voltage. Bad connection at supply cord. Failed compressor.	Adjust control or replace Correct Replace or repair Replace
Unit runs continuously	Low on refrigerant Control failure Restricted air flow or dirty condenser coil. Bad condenser fan motor Compressor failure. Ineffective door seal. Air circulation in storage restricted.	Leak-check system and recharge Adjust control or replace. Rectify air flow problem and clean condenser. Check and replace if necessary Replace. Adjust door strike. Redistribute food and even air flow.
Low head pressure.	Defective compressor. Low refrigerant. Ambient temperature too low.	Replace. Leak check system and recharge Redistribute food for even air flow.
High head pressure	Blocked or dirty condenser. Ambient temperature too high. System contains air. Refrigerant overcharge.	Clean and remove any obstructions. Improve room temperature. Evacuate, change the filter dryer and recharge. Reduce refrigerant in the system.
Short cycling	Mul-adjusted control	Adjust control

This chart is provided for the assistance of qualified technicians only and is not intended for use by untrained or unauthorised service personnel.



SWITCH THE CONTROL PANEL POWER
TO THE "OFF" POSITION AND
DISCONNECT THE POWER SUPPLY
CORD BEFORE SERVICING.

CORRECTIVE MAINTENANCE TROUBLE SHOOTING GUIDE

SERVICE



The components addressed in the section are considered acceptable for repair using standard procedures. The skill level required to perform these repairs vary. Some require specific training and are not intended for use by untrained or unauthorized service personnel.

Procedures requiring refrigerant handling require certification.

If your unit is not operating properly contact Alto-Shaam® for the nearest authorized service agent. These are the only service agents the company will authorize to repair Alto-Shaam® units. Repairs made by any other service agents without prior authorization by Alto-Shaam® will void the warranty on the unit.



FEDERAL LAWS REQUIRE PROPER HANDLING AND DISPOSAL OF REFRIGERANT.

IT IS UNLAWFUL TO VENT ANY REFRIGERANT INTO THE ATMOSPHERE

Alto-Shaam, Inc. urges all individuals responsible for training, teaching or advising installation mechanics and service personnel to emphasize proper handling and charging techniques and strict adherence to limiting refrigerant charge amount to those specifically recommended by the manufacturers of refrigeration, air conditioning or heat-pump systems.

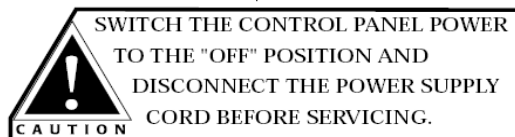

CORRECTIVE MAINTENANCE TROUBLE SHOOTING GUIDE

7.0 THERMOSTAT REPLACEMENT

- 1 Disconnect the unit from the power source.
- 2 Remove the front control panel and disconnect the electrical terminals.
- 3 By exerting correct strength slide the brackets from the rear of the control panel.
- 4 Remove the defective digital thermostat controller and replace with a new controller.
- 5 Start the system. Allow the system to operate for about 5 minutes. Re-enter the initial setpoint value.

7.1 FILTER DRYER REPLACEMENT

- 1 Close liquid line valve and run compressor until the low-side refrigeration gauge indicates 0 pounds. Close suction valve.
- 2 If the system is slightly pressurized, open both manifold gauge valves and purge the service gauge lines.
- 3 With manifold gauge valves closed, start the refrigeration system.
- 4 Attach a drum of refrigerant to the suction service side of the manifold gauges and add refrigerant through the suction side until the liquid sight glass is clear of bubbles.

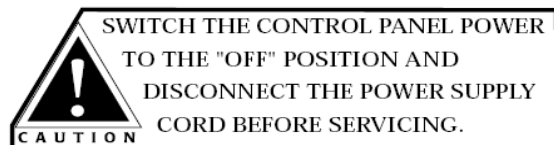

SERVICE PARTS

MR2

MR2

DESCRIPTION	QUANTITY	PART NUMBER	DESCRIPTION	QUANTITY	PART NUMBER
RUBBER WHEEL 5"	3	191115	Filter Dryer	1	13402
ROLLER BRAKE			Accumulator	1	13510
RUBBER WHEEL 5"	3	191154	Access valve	1	146014
FIX			Heater Door	9 m.	1128225
COMP.220V 50Hz	1	1175007	Gasket Assy	2	04URALTO2DB001
COND. COIL	1	2541011	PVC. Shelf(498x683)	8	170149
COND.FAN MOTOR	1	1105009	Shelf Support	24	0091041
(Complete set)			S/S Shelf post	8	009147
DRAIN HOT GAS	1	048102	Side Handle	2	990120
Door Hinge	4	1811	Start Capacitor	1	0955015
Door Latch Handle	2	118035	Starting Relay Comp.	1	0956002
Evaporator coil	1	26515512	Power Control Switch	1	1099115
Evaporator fan motor	2	11009109	Thermostat	1	0874002CX
PVC BOX	1	073840			

SERVICE PARTS (MR2)

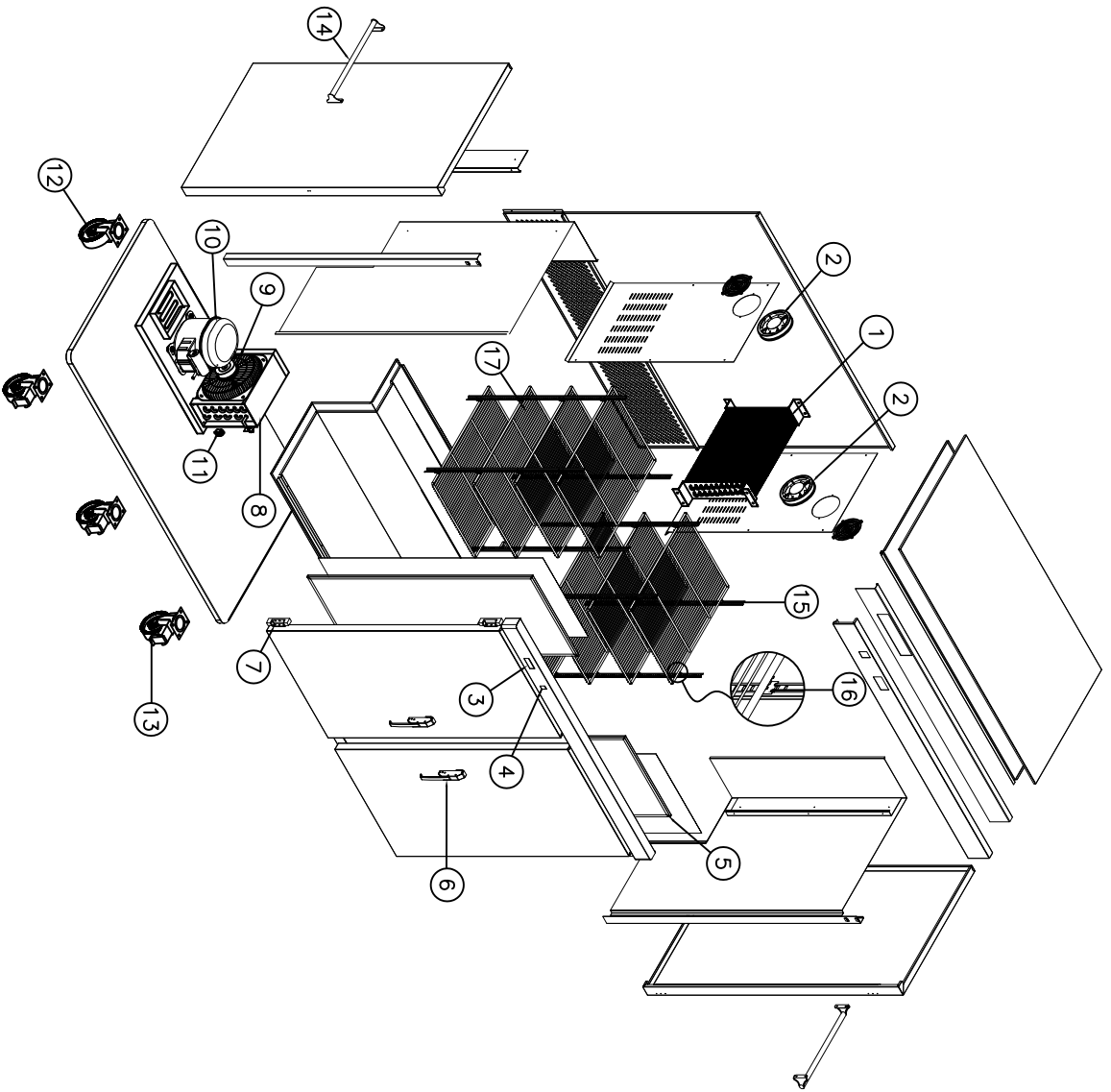

ITEM NO.	PART NUMBER	DESCRIPTION
1	26515512	EVAPORATOR COIL
2	11009109	EVAPORATOR FAN MOTOR
3	0874002CX	DIGITAL THERMOSTAT
4	1099115	POWER CONTROL SWITCH
5	04URALTO02DB001	GASKET ASSY
6	118035	DOOR LATCH HANDLE
7	1811	DOOR HINGE
8	2541011	CONDENSER COIL
9	1105009	CONDENSER FAN MOTOR (COMPLETE SET)
10	1175007	COMPRESSOR
11	13402	FILTER DRYER
12	191154	RUBBER WHEELS ⁵ FIX
13	191115	RUBBER WHEELS ⁵ ROLLER BRAKE
14	990120	SIDE HANDLE
15	009147	S/S SHELF POST
16	0091041	SHELF SUPPORT
17	170149	PVC SHELF (498x683)

SERVICE PARTS CONDENSING UNIT (MR2)

ITEM NO.	PART NUMBER	DESCRIPTION
1	1175007	COMPRESSOR
2	2541011	CONDENSER COIL
3	1105009	CONDENSER FAN MOTOR (COMPLETE SET)
4	13402	FILTER DRYER
5	13510	ACCUMULATOR
6	048102	DRAIN HOT GAS
7	146014	ACCESS VALVE

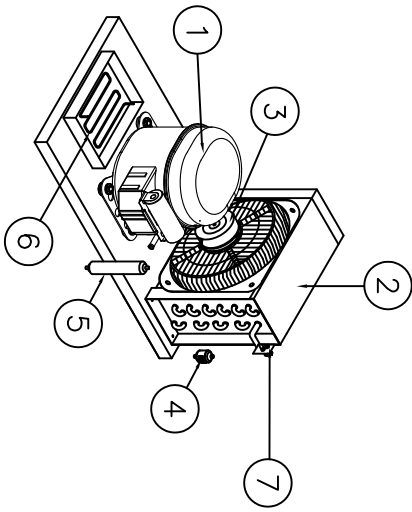

Parts Identification

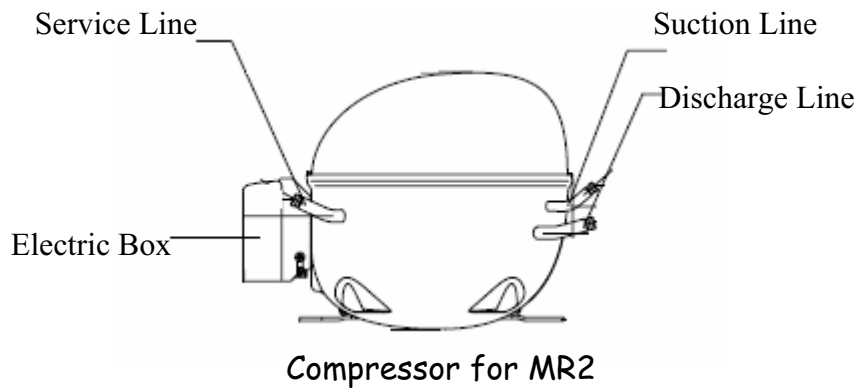

Parts Identification

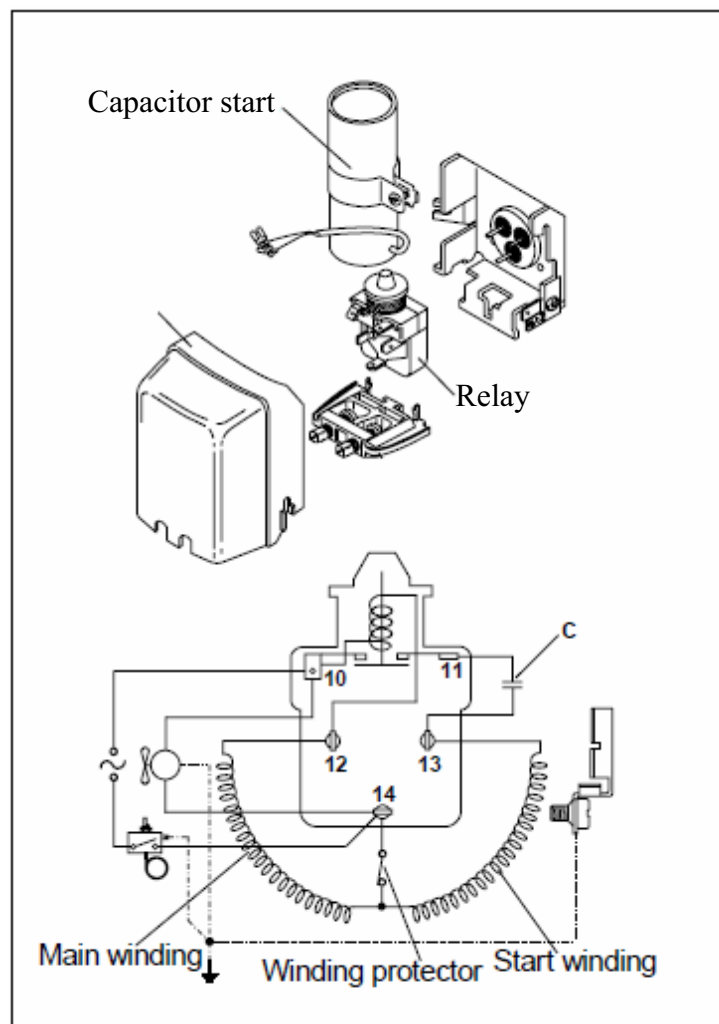

Inside Electric Box of Compressor

WIRING DIAGRAM FOR MOBILE REFRIGERATED CART(MR2)

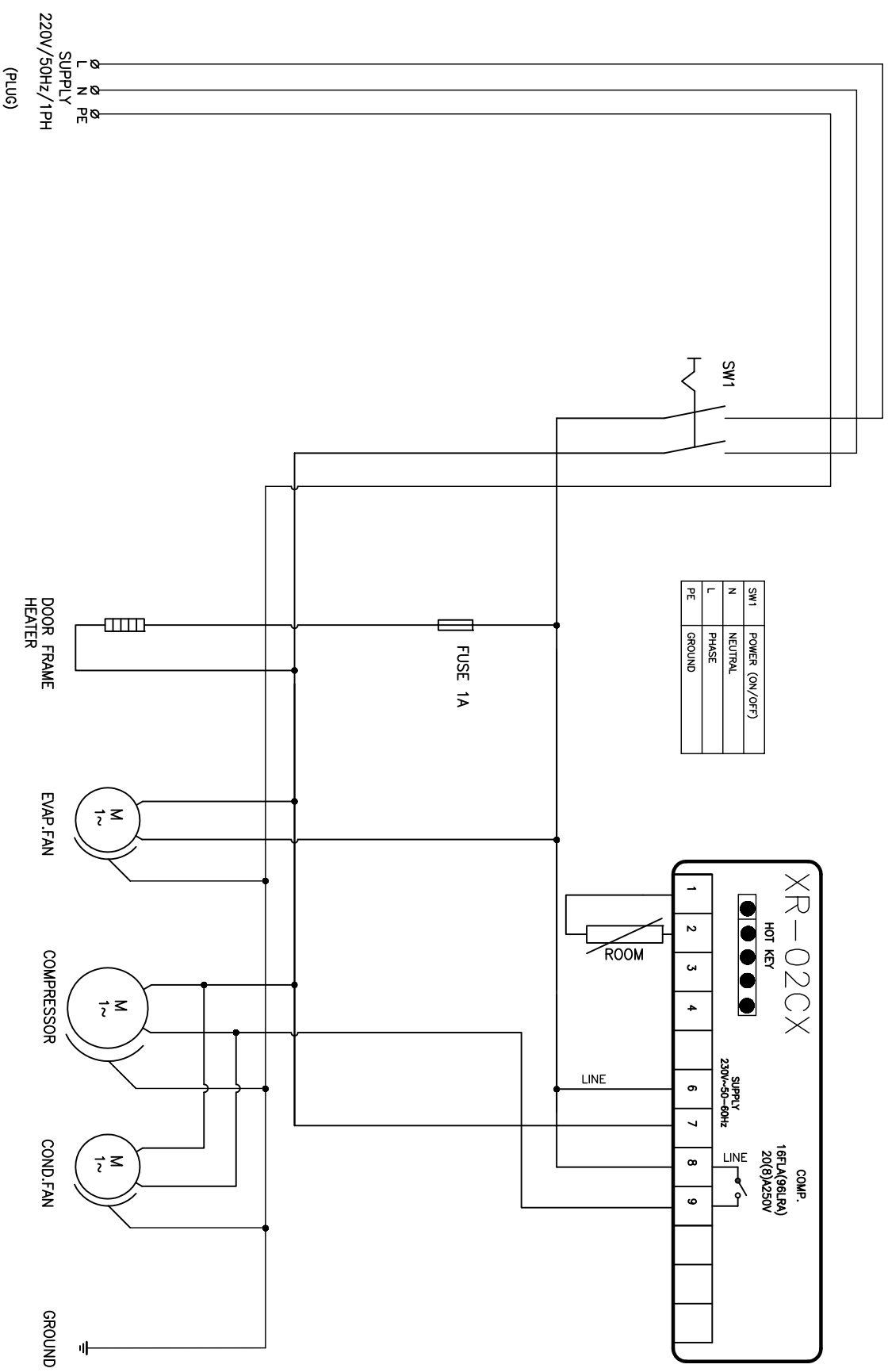

TRANSPORTATION DAMAGE and CLAIMS



All Alto-Shaam equipment is sold F.O.B. shipping point, and when accepted by the carrier, such shipments become the property of the consignee.

Should damage occur in shipment, it is a matter between the carrier and the consignee. In such cases, the carrier is assumed to be responsible for the safe delivery of the merchandise, unless negligence can be established on the part of the shipper.

1. Make an immediate inspection while the equipment is still in the truck or immediately after it is moved to the receiving area. Do not wait until after the material is moved to a storage area.
2. Do not sign a delivery receipt or a freight bill until you have made a proper count and inspection of all merchandise received.
3. Note all damage to packages directly on the carrier's delivery receipt.
4. Make certain the driver signs this receipt. If he refuses to sign, make a notation of this refusal on the receipt.
5. If the driver refuses to allow inspection, write the following on the delivery receipt:
Driver refuses to allow inspection of containers for visible damage.
6. Telephone the carrier's office immediately upon finding damage, and request an inspection. Mail a written confirmation of the time, date, and the person called.
7. Save any packages and packing material for further inspection by the carrier.
8. Promptly file a written claim with the carrier and attach copies of all supporting paperwork.

We will continue our policy of assisting our customers in collecting claims which have been properly filed and actively pursued. We cannot, however, file any damage claims for you, assume the responsibility of any claims, or accept deductions in payment for such claims.

LIMITED WARRANTY

Alto-Shaam, Inc. warrants to the original purchaser only that any original part that is found to be defective in material or workmanship will, at Alto-Shaam's option, subject to provisions hereinafter stated, be replaced with a new or rebuilt part.

The parts warranty period is as follows:

For the refrigeration compressor on Alto-Shaam Quickchillers™, five (5) years from the date of installation.

For the heating element on Halo Heat® cooking and holding ovens, as long as the original purchaser owns the oven. This excludes holding only equipment.

For all other parts, one (1) year from the date of installation or fifteen (15) months from the shipping date, whichever occurs first.

The labor warranty period is one (1) year from the date of installation or fifteen (15) months from the shipping date, whichever occurs first.

Alto-Shaam will bear normal labor charges performed during standard business hours, excluding overtime, holiday rates or any additional fees.

To be valid, a warranty claim must be asserted during the applicable warranty period. This warranty is not transferable.

THIS WARRANTY DOES NOT APPLY TO:

1. Calibration.
2. Replacement of light bulbs, door gaskets, and/or the replacement of glass due to damage of any kind.
3. Equipment damage caused by accident, shipping, improper installation or alteration.
4. Equipment used under conditions of abuse, misuse, carelessness or abnormal conditions, including but not limited to, equipment subjected to harsh or inappropriate chemicals, including but not limited to, compounds containing chloride or quaternary salts, poor water quality, or equipment with missing or altered serial numbers.
5. Damage incurred as a direct result of poor water quality, inadequate maintenance of steam generators and/or surfaces affected by water quality. Water quality and required maintenance of steam generating equipment is the responsibility of the owner/operator.
6. Damage caused by use of any cleaning agent other than Alto-Shaam's Combitherm® Cleaner, including but not limited to damage due to chlorine or other harmful chemicals. **Use of Alto-Shaam's Combitherm® Cleaner on Combitherm® ovens is highly recommended.**
7. Any losses or damage resulting from malfunction, including loss of product, food product, revenue, or consequential or incidental damages of any kind.
8. Equipment modified in any manner from original model, substitution of parts other than factory authorized parts, removal of any parts including legs, or addition of any parts.

This warranty is exclusive and is in lieu of all other warranties, express or implied, including the implied warranties of merchantability and fitness for a particular purpose. In no event shall Alto-Shaam be liable for loss of use, loss of revenue or profit, or loss of product, or for any indirect, special, incidental, or consequential damages. No person except an officer of Alto-Shaam, Inc. is authorized to modify this warranty or to incur on behalf of Alto-Shaam any other obligation or liability in connection with Alto-Shaam equipment.



Effective November 1, 2011

RECORD THE MODEL AND SERIAL NUMBER OF THE APPLIANCE FOR EASY REFERENCE.

ALWAYS REFER TO BOTH MODEL AND SERIAL NUMBER IN ANY CONTACT WITH ALTO-SHAAM REGARDING THIS APPLIANCE.

Model: _____ Date Installed: _____
Voltage: _____ Purchased From: _____
Serial Number: _____

W164 N9221 Water Street • P.O. Box 450 • Menomonee Falls, Wisconsin 53052-0450 • U.S.A.
PHONE: 262.251.3800 • 800.558-8744 USA/CANADA FAX: 262.251.7067 • 800.329.8744 U.S.A. ONLY

www.alto-shaam.com

PRINTED IN U.S.A.

Free Manuals Download Website

<http://myh66.com>

<http://usermanuals.us>

<http://www.somanuals.com>

<http://www.4manuals.cc>

<http://www.manual-lib.com>

<http://www.404manual.com>

<http://www.luxmanual.com>

<http://aubethermostatmanual.com>

Golf course search by state

<http://golfingnear.com>

Email search by domain

<http://emailbydomain.com>

Auto manuals search

<http://auto.somanuals.com>

TV manuals search

<http://tv.somanuals.com>