

ASUS[®]

TS300-E3/PA4 & PS4

Intel[®] Pentium[®] 4/Pentium[®] D LGA775
Pedestal/5U Rackmount Server
1066/800 MHz Front Side Bus



E2369

Revised Edition V2

January 2006

Copyright © 2006 ASUSTeK COMPUTER INC. All Rights Reserved.

No part of this manual, including the products and software described in it, may be reproduced, transmitted, transcribed, stored in a retrieval system, or translated into any language in any form or by any means, except documentation kept by the purchaser for backup purposes, without the express written permission of ASUSTeK COMPUTER INC. ("ASUS").

ASUS provides this manual "as is" without warranty of any kind, either express or implied, including but not limited to the implied warranties or conditions of merchantability or fitness for a particular purpose. In no event shall ASUS, its directors, officers, employees, or agents be liable for any indirect, special, incidental, or consequential damages (including damages for loss of profits, loss of business, loss of use or data, interruption of business and the like), even if ASUS has been advised of the possibility of such damages arising from any defect or error in this manual or product.

Specifications and information contained in this manual are furnished for informational use only, and are subject to change at any time without notice, and should not be construed as a commitment by ASUS. ASUS assumes no responsibility or liability for any errors or inaccuracies that may appear in this manual, including the products and software described in it.

Product warranty or service will not be extended if: (1) the product is repaired, modified or altered, unless such repair, modification or alteration is authorized in writing by ASUS; or (2) the serial number of the product is defaced or missing.

Products and corporate names appearing in this manual may or may not be registered trademarks or copyrights of their respective companies, and are used only for identification or explanation and to the owners' benefit, without intent to infringe.

Contents

Notices.....	vii
Safety information	viii
About this guide	ix

Chapter 1: Product introduction

1.1	System package contents	1-2
1.2	System specifications	1-3
1.2	System specifications	1-4
1.3	Front panel features.....	1-5
1.4	Rear panel features.....	1-6
1.5	Internal features	1-7
1.6	LED information	1-9

Chapter 2: Hardware setup

2.1	Chassis cover.....	2-2
2.1.1	Removing the side cover	2-2
2.1.2	Reinstalling the side cover	2-3
2.2	Motherboard overview.....	2-4
2.3	Central Processing Unit (CPU)	2-5
2.3.1	Installing the CPU	2-5
2.3.2	Installing the CPU heatsink and airduct assembly.....	2-8
2.4	System memory	2-10
2.4.1	Overview	2-10
2.4.2	Memory configurations.....	2-10
2.4.3	Installing a DIMM	2-11
2.4.4	Removing a DIMM	2-11
2.5	Front panel assembly	2-12
2.5.1	Removing the front panel assembly.....	2-12
2.5.2	Reinstalling the front panel assembly	2-14
2.6	5.25-inch drives	2-15
2.7	Hard disk drives	2-18
2.7.1	Installing a hot-swap SATA/SCSI HDD	2-18
2.7.2	Installing an HDD dummy cover	2-20
2.8	Expansion cards	2-21
2.8.1	Installing an expansion card	2-21
2.8.2	Removing an expansion card	2-22

Contents

- 2.9 Cable connections 2-23**
 - 2.9.1 Motherboard connections 2-23
 - 2.9.2 SATA backplane connections 2-24
 - 2.9.3 SCSI backplane connections 2-27
- 2.10 Removable components..... 2-30**
 - 2.10.1 Chassis fan 2-30
 - 2.10.2 HDD blower..... 2-32
 - 2.10.3 SATA/SCSI backplane 2-35
 - 2.10.4 Floppy disk drive 2-37
 - 2.10.5 Front I/O board..... 2-39
 - 2.10.6 Chassis footpads and roller wheels 2-41
 - 2.10.7 Power supply unit..... 2-43
- Chapter 3: Installation option**
 - Preparing the system for rack mounting..... 3-2**
- Chapter 4: Motherboard info**
 - 4.1 Motherboard layouts..... 4-2**
 - 4.2 Jumpers 4-5**
 - 4.3 Internal connectors..... 4-10**
- Chapter 5: BIOS information**
 - 5.1 Managing and updating your BIOS 5-2**
 - 5.1.1 Creating a bootable floppy disk..... 5-2
 - 5.1.2 AFUDOS utility 5-3
 - 5.1.3 ASUS CrashFree BIOS 2 utility 5-6
 - 5.1.4 ASUS Update utility 5-8
 - 5.2 BIOS setup program 5-11**
 - 5.2.1 BIOS menu screen..... 5-12
 - 5.2.2 Menu bar..... 5-12
 - 5.2.3 Navigation keys..... 5-12
 - 5.2.4 Menu items 5-13
 - 5.2.5 Sub-menu items..... 5-13
 - 5.2.6 Configuration fields 5-13
 - 5.2.7 Pop-up window 5-13
 - 5.2.8 Scroll bar..... 5-13
 - 5.2.9 General help 5-13

Contents

5.3	Main menu	5-14
5.3.1	System Time	5-14
5.3.2	System Date	5-14
5.3.3	Legacy Diskette A	5-14
5.3.4	IDE Configuration.....	5-15
5.3.5	Primary, Secondary, Third, Fourth IDE Master/Slave ...	5-16
5.3.6	System Information	5-18
5.4	Advanced menu	5-19
5.4.1	MPS Configuration.....	5-19
5.4.2	CPU Configuration	5-20
5.4.3	Chipset Configuration	5-22
5.4.4	Onboard Devices Configuration.....	5-26
5.4.5	PCI PnP	5-27
5.5	Power Configuration.....	5-28
5.5.1	ACPI APIC support	5-28
5.5.2	APM configuration.....	5-28
5.5.3	Hardware Monitor	5-31
5.6	Server menu	5-33
	Remote Access Configuration.....	5-33
5.7	Boot menu	5-35
5.7.1	Boot Device Priority	5-35
5.7.2	Boot Settings Configuration	5-36
5.7.3	Security	5-37
5.8	Exit menu	5-40
 Chapter 6: RAID Configuration		
6.1	Setting up RAID.....	6-2
6.1.1	RAID definitions	6-2
6.1.2	Installing hard disk drives.....	6-3
6.1.3	Setting the RAID item in BIOS	6-3
6.1.4	RAID configuration utilities.....	6-4
6.2	LSI Logic Embedded SATA RAID Setup Utility.....	6-5
6.2.1	Creating a RAID 0 or RAID 1 set	6-6
6.2.2	Creating a RAID 10 set	6-11
6.2.3	Adding or viewing a RAID configuration	6-15
6.2.4	Initializing the logical drives	6-18
6.2.5	Rebuilding failed drives.....	6-23
6.2.6	Checking the drives for data consistency	6-25

Contents

6.2.7	Deleting a RAID configuration.....	6-28
6.2.8	Selecting the boot drive from a RAID set.....	6-29
6.2.9	Enabling the WriteCache	6-30
6.3	Global Array Manager.....	6-30
6.4	Adaptec SCSISelect(TM) Utility! (P5MT-S model only).....	6-31
6.4.1	Configuring the SCSI controller	6-32
6.4.2	Enabling the HostRAID controller	6-33
6.4.3	Creating a RAID 0 set (Stripe)	6-34
6.4.4	Creating a RAID 1 set (Mirror)	6-37
6.4.5	Creating a RAID 10 set (Stripe+Mirror).....	6-41
6.4.6	Adding a spare drive to a RAID 10 set.....	6-45
6.4.7	Deleting a RAID 10 set spare drive.....	6-46
6.4.8	Deleting a RAID set	6-48
6.4.9	Rebuilding a RAID set.....	6-49
6.4.10	Verifying a RAID set hard disk drive	6-50
6.4.11	Making a RAID set bootable	6-51
 Chapter 7: Driver installation		
7.1	RAID driver installation	7-2
7.1.1	Creating a RAID driver disk	7-2
7.1.2	Installing the RAID controller driver	7-3
7.2	LAN driver installation.....	7-12
7.2.1	Windows® 2000/2003 Server	7-12
7.2.2	Red Hat® Enterprise ver. 3.0	7-13
7.3	VGA driver installation	7-14
7.3.1	Windows® 2000 Server	7-14
7.3.2	Windows® 2003 Server	7-15
7.3.3	Red Hat® Enterprise ver. 3.0	7-15
7.4	Management applications and utilities installation	7-16
7.4.1	Running the support CD	7-16
7.4.2	Drivers menu.....	7-16
7.4.3	Management Software menu.....	7-17
7.4.4	Utilities menu	7-17
7.4.5	Contact information.....	7-17
 Appendix: Reference information		
A.1	450 W single power supply	A-2
A.1.1	General description.....	A-2
A.1.2	Specifications.....	A-3
A.2	Simple fixes	A-4

Notices

Federal Communications Commission Statement

This device complies with Part 15 of the FCC Rules. Operation is subject to the following two conditions:

- This device may not cause harmful interference, and
- This device must accept any interference received including interference that may cause undesired operation.

This equipment has been tested and found to comply with the limits for a Class B digital device, pursuant to Part 15 of the FCC Rules. These limits are designed to provide reasonable protection against harmful interference in a residential installation. This equipment generates, uses and can radiate radio frequency energy and, if not installed and used in accordance with manufacturer's instructions, may cause harmful interference to radio communications. However, there is no guarantee that interference will not occur in a particular installation. If this equipment does cause harmful interference to radio or television reception, which can be determined by turning the equipment off and on, the user is encouraged to try to correct the interference by one or more of the following measures:

- Reorient or relocate the receiving antenna.
- Increase the separation between the equipment and receiver.
- Connect the equipment to an outlet on a circuit different from that to which the receiver is connected.
- Consult the dealer or an experienced radio/TV technician for help.



WARNING! The use of shielded cables for connection of the monitor to the graphics card is required to assure compliance with FCC regulations. Changes or modifications to this unit not expressly approved by the party responsible for compliance could void the user's authority to operate this equipment.

Canadian Department of Communications Statement

This digital apparatus does not exceed the Class B limits for radio noise emissions from digital apparatus set out in the Radio Interference Regulations of the Canadian Department of Communications.

This class B digital apparatus complies with Canadian ICES-003.

Safety information

Electrical Safety

- Before installing or removing signal cables, ensure that the power cables for the system unit and all attached devices are unplugged.
- To prevent electrical shock hazard, disconnect the power cable from the electrical outlet before relocating the system.
- When adding or removing any additional devices to or from the system, ensure that the power cables for the devices are unplugged before the signal cables are connected. If possible, disconnect all power cables from the existing system before you add a device.
- If the power supply is broken, do not try to fix it by yourself. Contact a qualified service technician or your dealer.

Operation Safety

- Any mechanical operation on this server must be conducted by certified or experienced engineers.
- Before operating the server, carefully read all the manuals included with the server package.
- Before using the server, make sure all cables are correctly connected and the power cables are not damaged. If any damage is detected, contact your dealer as soon as possible.
- To avoid short circuits, keep paper clips, screws, and staples away from connectors, slots, sockets and circuitry.
- Avoid dust, humidity, and temperature extremes. Place the server on a stable surface.



This product is equipped with a three-wire power cable and plug for the user's safety. Use the power cable with a properly grounded electrical outlet to avoid electrical shock.

Lithium-Ion Battery Warning

CAUTION! Danger of explosion if battery is incorrectly replaced. Replace only with the same or equivalent type recommended by the manufacturer. Dispose of used batteries according to the manufacturer's instructions.

CD-ROM Drive Safety Warning

CLASS 1 LASER PRODUCT

Heavy System

CAUTION! This server system is heavy. Ask for assistance when moving or carrying the system.

About this guide

Audience

This user guide is intended for system integrators and experienced users with at least basic knowledge of configuring a server.

Contents

This guide contains the following parts:

1. **Chapter 1: Product Introduction**

This chapter describes the general features of the server, including sections on front panel and rear panel specifications.

2. **Chapter 2: Hardware setup**

This chapter lists the hardware setup procedures that you have to perform when installing or removing system components.

3. **Chapter 3: Installation options**

This chapter describes how to install optional components into the barebone server.

4. **Chapter 4: Motherboard information**

This chapter gives information about the motherboard that comes with the server. This chapter includes the motherboard layout, jumper settings, and connector locations.

5. **Chapter 5: BIOS information**

This chapter tells how to change system settings through the BIOS Setup menus and describes the BIOS parameters.

6. **Chapter 6: RAID configuration**

This chapter provides information on how to configure your hard disk drives as RAID sets.

7. **Chapter 7: Driver installation**

This chapter provides information on how to create a RAID set and how to install the drivers for system components. This chapter also describes the software applications that the barebone server supports.

8. **Appendix: Reference information**

This section provides information about the power supply unit and a troubleshooting guide for solving common problems when using the barebone server.

Conventions

To make sure that you perform certain tasks properly, take note of the following symbols used throughout this manual.



WARNING: Information to prevent injury to yourself when trying to complete a task.



CAUTION: Information to prevent damage to the components when trying to complete a task.



IMPORTANT: Instructions that you **MUST** follow to complete a task.



NOTE: Tips and information to aid in completing a task.

Reference

Visit the ASUS websites worldwide that provide updated information for all ASUS hardware and software products. Refer to the ASUS contact information for details.

Chapter 1

This chapter describes the general features of the barebone server, including sections on the front panel and rear panel specifications.



1.1 System package contents

Check your ASUS TS300-E3 package with the items on the following table. The package contents vary for the following configurations:

- PA4 (four hot-swap Serial ATA hard disk drives)
- PS4 (four hot-swap SCSI hard disk drives)

Item description	Configuration	
	PA4	PS4
ASUS TS300-E3 5U rackmount chassis with:		
• ASUS P5MT motherboard	●	
• ASUS P5MT-S motherboard		●
• 450 W single power supply	●	●
• SATA backplane board	●	
• SCSI backplane board		●
• Floppy disk drive	●	●
• 9 cm Blower	●	●
• 12 cm Chassis fan	●	●
• Hot-swap HDD trays (including HDD screws)	4	4
• Chassis roller wheels	4	4
• Front I/O board	●	●
• Dummy covers	●	●
Cables		
• AC power cable	●	●
• SATA signal cables	●	
• SCSI signal cables		●
• SMBus cable	●	●
System screws and cables	●	●
System keys (2 pcs.)	●	●
Bundled CDs		
• TS300-E3 support CD with ASWM*	●	●
• Computer Associates® eTrust™ anti-virus CD	●	●
Documentation		
• ASUS TS300-E3 user guide	●	●
• ASUS ASWM 2.0 user guide	●	●
Optional items		
• 52x IDE CD-ROM or 16X DVD-ROM drive	●	●
• ASUS TS300-E3 rackmount rail kit	●	●

*ASUS System Web-based Management

1.2 System specifications

The ASUS TS300-E3 is a barebone server system featuring the ASUS P5MT Series motherboard. The server supports an Intel® Pentium® 4/Pentium® D processor in the 775-land package, and includes the latest technologies through the chipsets embedded on the motherboard.

Chassis	Pedestal or rackmount 5U with removable front door bezel and chassis foot stand or roller-wheels.
Motherboard	ASUS P5MT (PA4 model) ASUS P5MT-S (PS4 model) ATX compatible form factor: 12 in x 9.6 in
Chipset	Northbridge: Intel® E7230 Memory Controller Hub (MCH) Southbridge: Intel® ICH7R I/O Bridge: Intel® 6702 PXH
Processor	Intel® Pentium® 4/Intel® Pentium® D processor in the 775-land package with Extended Memory 64-bit Technology (EM64T) Supports Dual Core technology
Front Side Bus	1066/800/533 MHz
Memory	Dual-channel memory architecture 4 x 240-pin DIMM sockets support ECC/non-ECC unbuffered 667/533 MHz DDR2 memory modules Supports 256 MB up to 8 GB of system memory
LAN	Dual Broadcom® BCM5721 Gigabit LAN controllers - PCI Express 1.0a specifications compliant
Storage	<u>For PA4 model only</u> Intel® ICH7R Southbridge supports: <ul style="list-style-type: none">- 4 x Serial ATA 3 Gb/s hard disk drives- RAID 0, RAID 1, RAID 0+1, and RAID 5 (with limited OS support) configuration- Intel® Matrix Storage Technology- LSI Logic Embedded SATA RAID controller (RAID 0, RAID 1, RAID 10) <u>For PS4 model only</u> Adaptec AIC-7901 SCSI controller supports: <ul style="list-style-type: none">- 1 x Ultra 320 SCSI channel with RAID 0, RAID 1, and RAID 10 configuration- Zero-Channel RAID (<i>optional</i>)

(continued on the next page)

1.2 System specifications

Expansion slots	1 x PCI 33 MHz/32-bit/5V (PCI 2.3) 1 x PCI-X 100 MHz/64-bit slot (PCI-X 1.0) 1 x PCI-X 100 MHz/64-bit slot (supports ZCR, PCI-X 1.0)* <i>(colored green on PS4 model)</i> 1 x PCI Express™ x16 slot (x8 Link)** 1 x Mini-PCI socket for the ASUS Server Management Board
Drive bays	1 x 3.25-inch FDD bay 3 x 5.25-inch drive bays
Front panel	2 x USB 2.0 ports
Rear panel	1 x Serial port 1 x Parallel port 1 x PS/2 keyboard port 1 x PS/2 mouse port 2 x LAN (RJ-45) ports 2 x USB 2.0 ports 1 x VGA port
Management	ASUS Server Web-based Management (ASWM) 2.0 ASUS Server Monitoring Agent (ASMA)
Hardware monitors	Voltage, temperature, CPU and memory utilization, storage capacity, and fan speed monitoring Automatic Server Restart (ASR) feature
Power supply	450 W single power supply <i>(with 24-pin and 4-pin power plugs)</i>



- * Only PS4 model supports Zero Channel RAID (ZCR).
- ** If you install a PCI Express VGA card, the link speed downgrades to x1 due to chipset limitation. This limitation applies only to VGA cards.

1.3 Front panel features

The TS300-E3 chassis displays a stylish front bezel with lock. The bezel covers the system components on the front panel and serves as security. Open the bezel to access the front panel components.

The drive bays, power and reset buttons, LED indicators, CD-ROM drive, floppy drive, and USB 2.0 ports are located on the front panel. For future installation of 5.25-inch devices, two drive bays are available.



1.4 Rear panel features

The rear panel includes a slot for the motherboard rear I/O ports, expansion slots, a chassis lock and intrusion switch, a vent for the system fan, and power supply module.

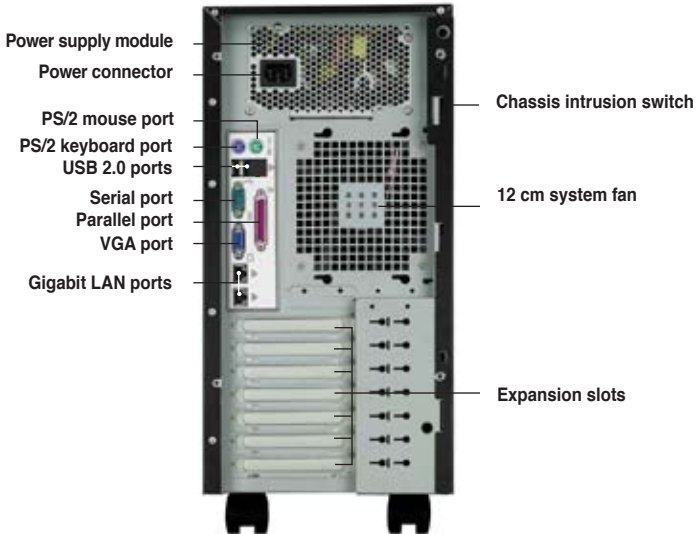

1.5 Internal features

The barebone server system includes the basic components as shown. The photo below shows the TS300-E3 with the hard disk drive blower installed. The HDD blower circulates cool air within the system.

PA4 (4 hot-swap SATA configuration)

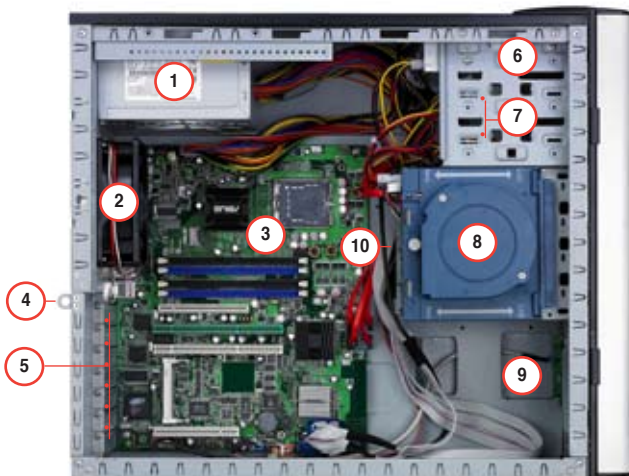

1. Power supply unit
2. Chassis fan
3. ASUS P5MT motherboard
4. Chassis intrusion switch
5. Expansion card locks
6. Optical drive
7. 2 x 5.25-inch drive bays
8. HDD blower (HDD drive cage inside)
9. Front I/O board
10. SATA backplane

PS4 (4 hot-swap SCSI configuration)

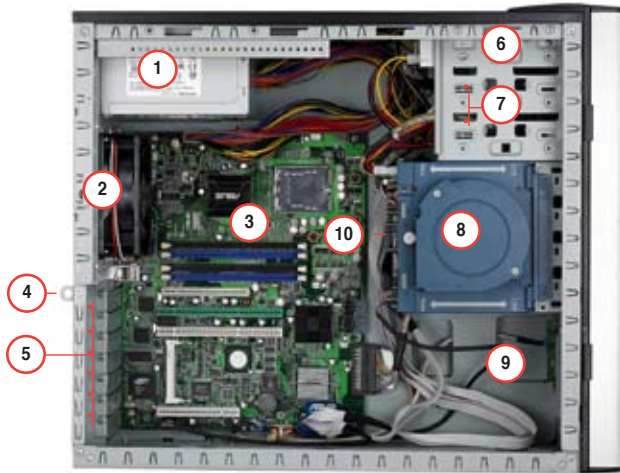

1. Power supply unit
2. Chassis fan
3. ASUS P5MT-S motherboard
4. Chassis intrusion switch
5. Expansion card locks
6. Optical drive
7. 2 x 5.25-inch drive bays
8. HDD blower (HDD drive cage inside)
9. Front I/O board
10. SCSI backplane

1.6 LED information

The barebone system comes with five LED indicators. Refer to the following table for the LED status description.

System and HDD LED

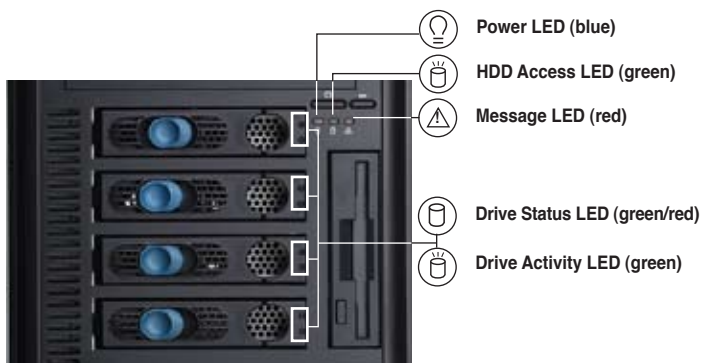

LED	Icon	Display status	Description
System			
Power LED		ON	System power ON
		Blinking	System is in suspend mode
HDD Access LED		OFF	No activity
		Blinking	Read/write data into the HDD
Message LED		OFF	System is normal; no incoming event
		Blinking	ASMS indicates a HW monitor event
Hard disk drives			
Drive Status LED		Green	Bridge board connected to backplane Installed HDD is in good condition
		Red	HDD failure
		Green/Red - Blinking	HDD rebuilding using the RAID card SAF-TE* function
Drive Activity LED		Blinking	Read/write data into the HDD

*SCSI Access Fault-Tolerant Enclosure (on PS4 model only)



The Power, HDD Access, and Message LEDs are visible even if the system front bezel is closed.

Chapter 2

This chapter lists the hardware setup procedures that you have to perform when installing or removing system components.



2.1 Chassis cover

The chassis features a “screwless design” that allows convenient assembly and disassembly. You can simply push or slide mechanical bolts and locks to remove the cover.

2.1.1 Removing the side cover

1. Remove the two screws that secure the cover to the chassis.

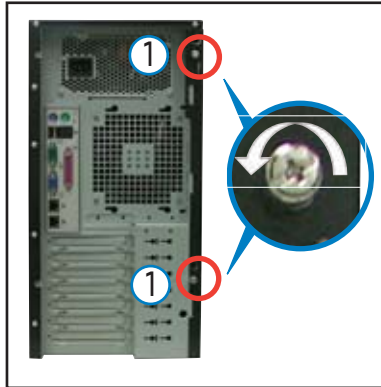

2. Slide the side cover for about half an inch toward the rear until it is disengaged from the chassis.
3. Carefully lift the cover and set it aside.



Viewing the internal structure

Without the side cover, the internal structure and installed components of the barebone server vary depending on the model you purchased. Refer to section “1.5 Internal features” for the different model configurations.

Perform the procedures in the succeeding sections to install the CPU, system memory, disk drives, and expansion cards; replace fans and power supply; and connect the system cables.



You may need to remove some of the installed components to access the DIMM sockets and internal connectors. Refer to section "2.10 Removable components" for instructions.

2.1.2 Reinstalling the side cover

To reinstall the side cover:

1. Match and insert the upper hooks and lower sliding edge of the cover to the corresponding chassis holes and edge.
2. Slide the cover toward the front until it snaps in place.



3. Drive in the two screws you removed earlier to secure the side cover.

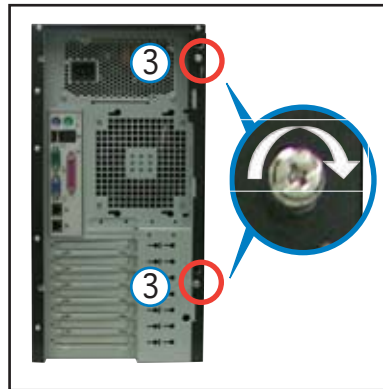

2.2 Motherboard overview

The barebone server comes with the P5MT (PA4 model) or P5MT-S (PS4 model) motherboard already installed. The motherboard is secured to the chassis by nine (9) screws as indicated by the circles in the illustration below.



Refer to “Chapter 4 Motherboard information” for detailed information on the motherboard.

Place this side towards
the rear of the chassis

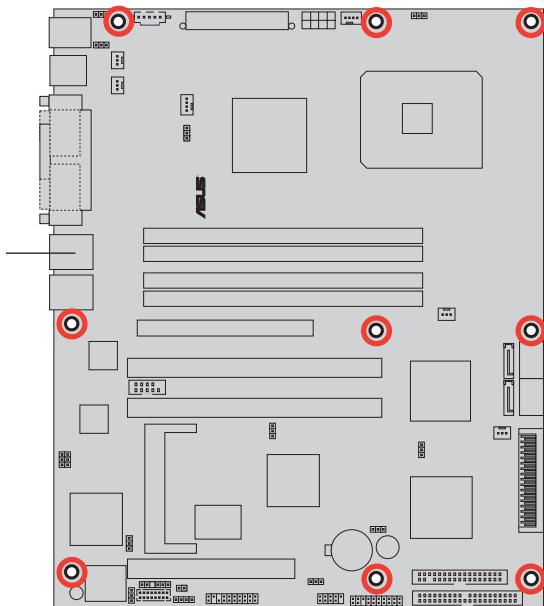

Make sure to unplug the power cord before installing or removing any motherboard component or connection. Failure to do so can cause you physical injury and damage motherboard components.

2.3 Central Processing Unit (CPU)

The motherboard comes with a surface mount LGA775 socket designed for the Intel® Pentium® 4 processor in the 775-land package

2.3.1 Installing the CPU

To install a CPU:

1. Locate the CPU socket on the motherboard.

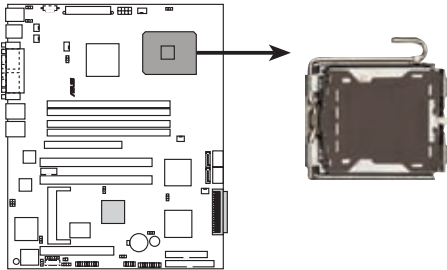

P5MT Series CPU Socket 775



Before installing the CPU, make sure that the socket box is facing towards you and the load lever is on your left.

2. Press the load lever with your thumb (A), then move it to the left (B) until it is released from the retention tab.

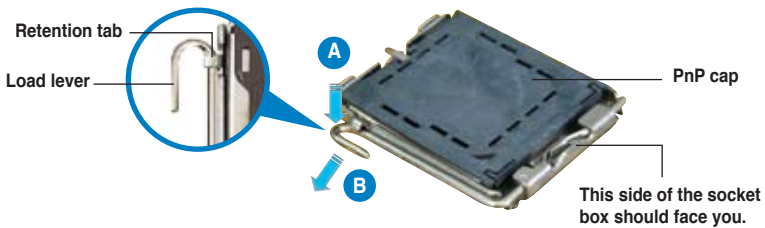

To prevent damage to the socket pins, do not remove the PnP cap unless you are installing a CPU.

3. Lift the load lever in the direction of the arrow to a 135° angle.

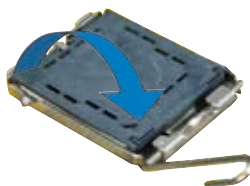

4. Lift the load plate with your thumb and forefinger to a 100° angle (A), then push the PnP cap from the load plate window to remove (B).

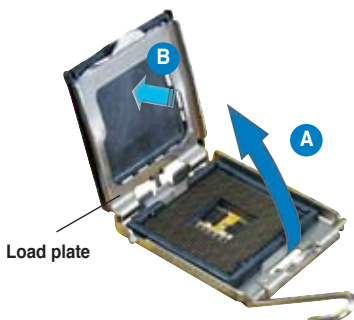

5. Position the CPU over the socket, making sure that the gold triangle is on the bottom-left corner of the socket. The socket alignment key should fit into the CPU notch.

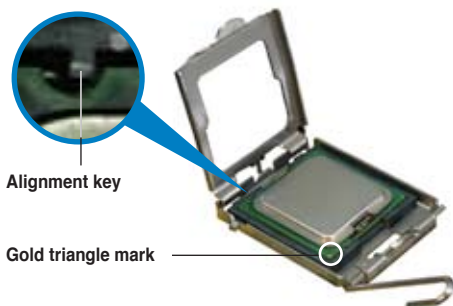



The CPU fits in only one correct orientation. DO NOT force the CPU into the socket to prevent bending the connectors on the socket and damaging the CPU!

6. Close the load plate (A), then push the load lever (B) until it snaps into the retention tab.



The motherboard supports Intel® Pentium® 4 LGA775 processors with the Intel® Enhanced Memory 64 Technology (EM64T), Enhanced Intel SpeedStep® Technology (EIST), and Hyper-Threading Technology. Refer to the Appendix for more information on these CPU features.

2.3.2 Installing the CPU heatsink and airduct assembly

The TS300-E3 comes with a proprietary CPU heatsink and airduct, which come in separate boxes when you receive the package. You have to assemble the CPU heatsink and airduct before installing to the motherboard.

To assemble the CPU heatsink and airduct:

1. Align the airduct pegs to the fan and heatsink holes.



2. Push down the airduct into the holes to secure the assembly.



To install the CPU heatsink and airduct assembly:

1. Locate the four screw holes on the motherboard.



2. Position the CPU heatsink and airduct assembly on top of the installed CPU, making sure that the heatsink screws match the screw holes on the motherboard.
3. Drive the four screws into the holes in a diagonal sequence to secure the heatsink and airduct assembly to the motherboard.

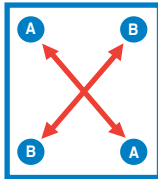
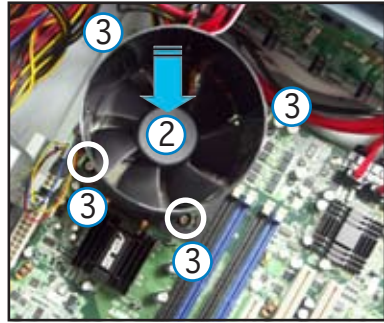

4. Connect the CPU fan cable to the connector on the motherboard labeled CPU_FAN1.

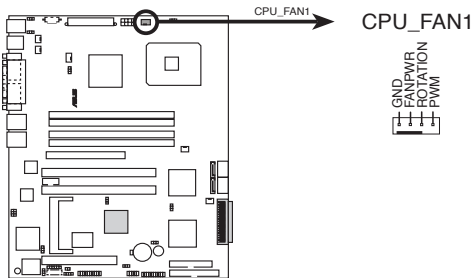

P5MT Series CPU fan connector



Do not forget to connect the CPU fan connector! Hardware monitoring errors can occur if you fail to plug the connector.

2.4 System memory

2.4.1 Overview

The motherboard comes with four Double Data Rate II (DDR2) Dual Inline Memory Modules (DIMM) sockets to support 240-pin DDR modules.

The figure illustrates the location of the DDR DIMM sockets:

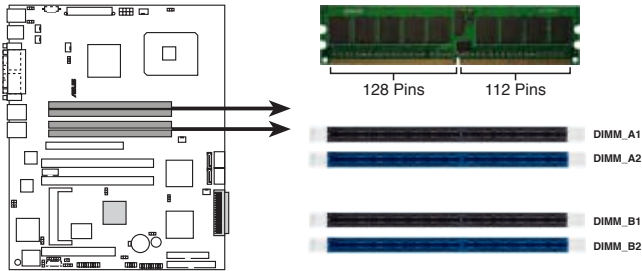

P5MT Series 240-pin DDR2 DIMM sockets

2.4.2 Memory configurations

You may install 256 MB, 512 MB, 1 GB, and 2 GB unbuffered ECC or non-ECC DDR2-533/667 DIMMs into the DIMM sockets.



- Always install DIMMs with the same CAS latency. For optimum compatibility, it is recommended that you obtain memory modules from the same vendor. Refer to the DDR2 Qualified Vendors List at the ASUS web site.
- When installing one or two DIMMs, install the DIMM(s) to the blue slots (DIMM_A2/DIMM_B2).
- Three DDR DIMMs installed into any three memory sockets will function in single-channel mode.

2.4.3 Installing a DIMM



Unplug the power supply before adding or removing DIMMs or other system components. Failure to do so can cause severe damage to both the motherboard and the components.

To install a DIMM:

1. Unlock a DIMM socket by pressing the retaining clips outward.
2. Align a DIMM on the socket such that the notch on the DIMM matches the break on the socket.
3. Firmly insert the DIMM into the socket until the retaining clips snap back in place and the DIMM is properly seated.

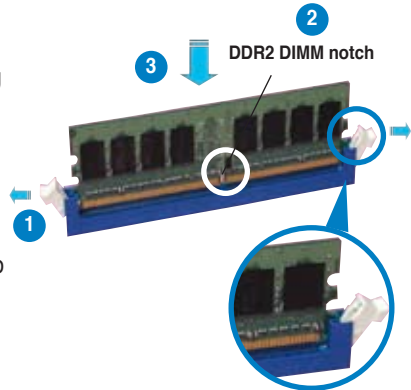

Unlocked retaining clip



- A DDR2 DIMM is keyed with a notch so that it fits in only one direction. Do not force a DIMM into a socket to avoid damaging the DIMM.
- The DDR2 DIMM sockets do not support DDR DIMMs. DO not install DDR DIMMs to the DDR2 DIMM sockets.

2.4.4 Removing a DIMM

To remove a DIMM:

1. Simultaneously press the retaining clips outward to unlock the DIMM.



Support the DIMM lightly with your fingers when pressing the retaining clips. The DIMM might get damaged when it flips out with extra force.

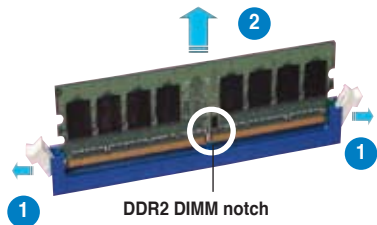

2. Remove the DIMM from the socket.

2.5 Front panel assembly

2.5.1 Removing the front panel assembly



Before you can install a 5.25-inch drive, you should first remove the front panel assembly (front bezel and front panel cover). The front panel assembly is attached to the chassis through three hooked tabs on the left side and four hinge-like tabs on the right side.

To remove the front panel assembly:

1. Locate the four hooked tabs on the chassis side rail.
2. Press each lock tab to release the front panel from the chassis.
3. Pull and swing the left edge of the front panel outward.

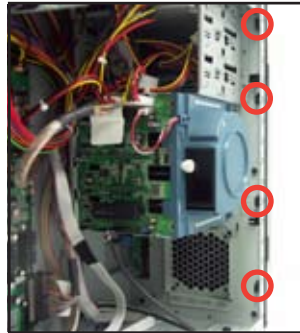

4. Unhook the hinge-like tabs from the holes on the right side of the front panel to completely detach the front panel assembly from the chassis.



Do not use too much force when removing the front panel assembly.

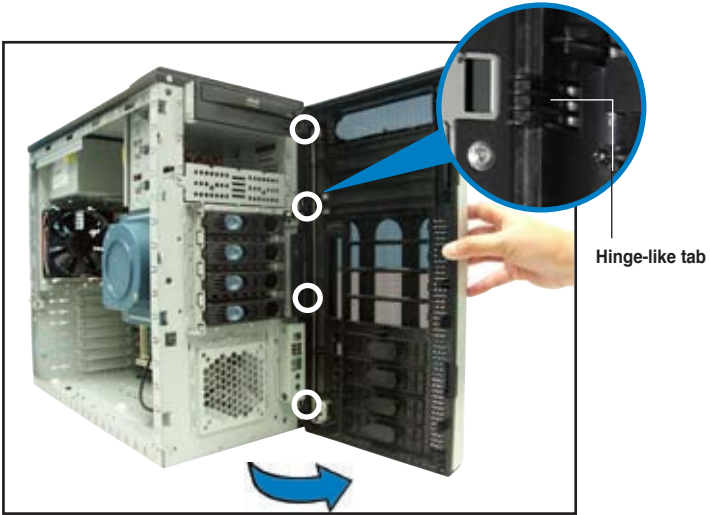

2.5.2 Reinstalling the front panel assembly

To reinstall the front panel assembly (front bezel and front panel cover):

1. Insert the four hinge-like tabs to the holes on the right edge of the chassis.
2. Swing the front panel to the left and fit the four (4) hooked tabs to the left side of the chassis until the tabs snap back in place.

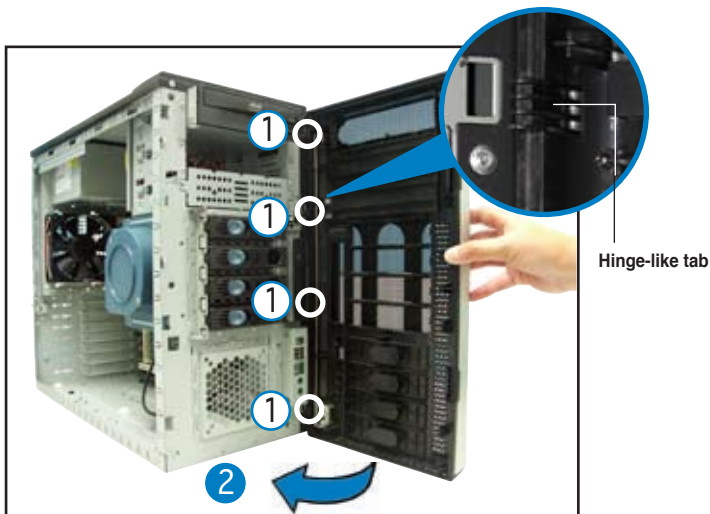

2.6 5.25-inch drives



If you have previously used and powered up the system, and that it may be connected to an AC power source, make sure to unplug the power cable before installing or removing any system components. Failure to do so may cause damage to the motherboard and other system components!

Three 5.25-inch drive bays are located on the upper front part of the chassis. A CD-ROM drive that comes standard with the system package occupies the uppermost bay (labeled 1). The two lower bays (labeled 2 and 3) are available for additional 5.25-inch devices.



To install a 5.25-inch drive:

1. Use a Phillips (cross) screwdriver to remove the screws that secure the metal cover of the bay where you want to install the drive.

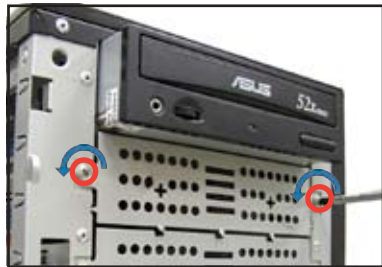

2. Insert the optical drive into the 5.25-inch drive bay.



3. Make sure that the drive and bay align as shown. When in place, the drive protrudes about an inch from the front panel.



4. Secure the drive with a screw.



5. Connect the IDE cable to the IDE connector on the back of the drive.
6. Connect a 4-pin plug from the power supply to the power connector on the back of the drive.

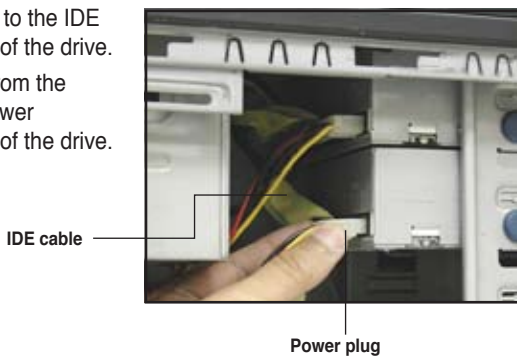

7. On the front panel assembly, detach the plastic bay cover opposite the 5.25-inch drive that you installed by pressing the two hooked tabs on each side of the bay cover.

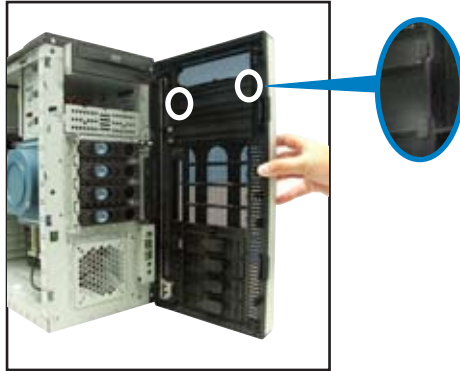

8. Reinstall the front panel assembly when done. Refer to section “2.5.2 Reinstalling the front panel assembly” for instructions.

2.7 Hard disk drives

2.7.1 Installing a hot-swap SATA/SCSI HDD

Follow the instructions in this section to install a hot-swap SATA (PA4 model) or SCSI (PS4 model) hard disk drive (HDD).

1. Open the front bezel to access the hot-swap drive trays.
2. Release a drive tray by pushing the spring lock to the right, then pulling the tray lever outward. The drive tray ejects slightly after you pull out the lever.



3. Firmly hold the tray lever and pull the drive tray out of the bay.

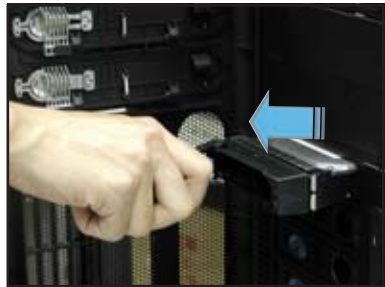

4. An empty drive tray requires a metal bracket for support. Use a Phillips (cross) screwdriver to remove the bracket when you are ready to install a hard disk in the drive tray.



5. Place a SATA or an SCA SCSI hard disk to the drive tray, and secure it with four screws.



6. Carefully insert drive tray and push it all the way to the depth of the bay until just a small fraction of the tray edge protrudes.

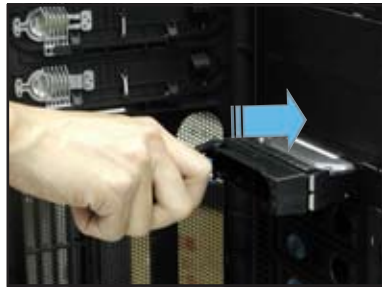

7. Push the tray lever until it clicks, and secures the drive tray in place. The drive tray is correctly placed when its front edge aligns with the bay edge.



2.7.2 Installing an HDD dummy cover

The HDD dummy covers come pre-installed on the front panel bezel. In case you removed the covers, follow these steps to re-install them.

To install an HDD dummy cover:

1. From the inside of the front panel assembly, insert the flat end of a dummy cover into the slot as shown. The end with the hook tab should be close to the front panel LEDs.



Flat end

2. Press the dummy cover into the slot opening until the hook tab clicks in place.

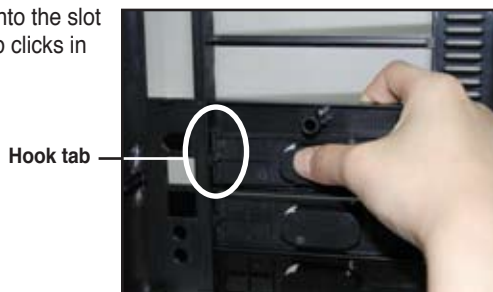

3. When installed, the dummy cover appears as shown.



2.8 Expansion cards

Refer to this section when installing expansion cards.



Make sure to unplug the power cord before installing or removing expansion cards. Failure to do so may cause physical injury, and damage to the card and motherboard components!

2.8.1 Installing an expansion card

To install an expansion card:

1. Lay the chassis on its side.
2. Locate the metal bracket opposite the slot you want to use.

Remove the screw that secures the metal bracket to the chassis. Set aside the metal bracket for future use.

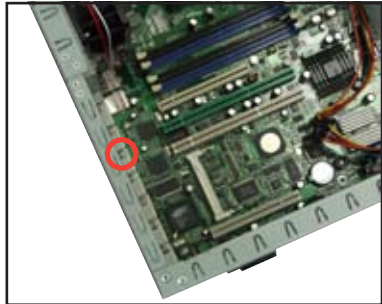

3. Align the card golden fingers to the slot and its metal bracket to the slot opening on the chassis.
4. Press the card firmly until it is properly seated on the slot.



5. Secure the card to the chassis with the bracket screw you removed earlier.

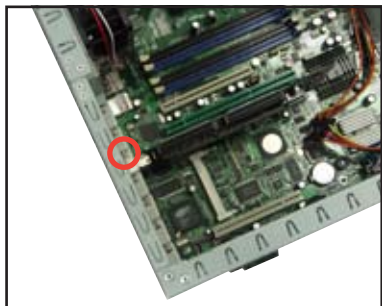

2.8.2 Removing an expansion card

To remove an expansion card:

1. Remove the screw that secures the card to the chassis.

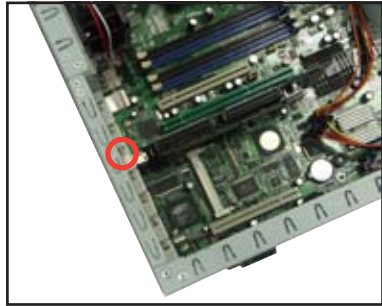

2. Carefully remove the card from the slot.

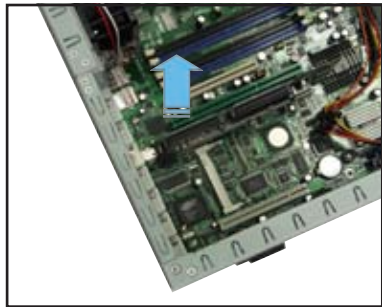

3. Reinstall the metal bracket and secure it to the chassis with the screw that you removed earlier.

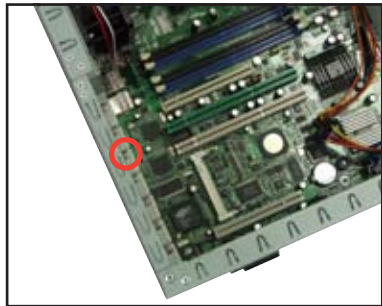

2.9 Cable connections



- The bundled system cables are pre-connected before shipment. You do not need to disconnect these cables unless you will remove pre-installed components to install additional devices.
- Refer to Chapter 4 for detailed information on the connectors.

2.9.1 Motherboard connections

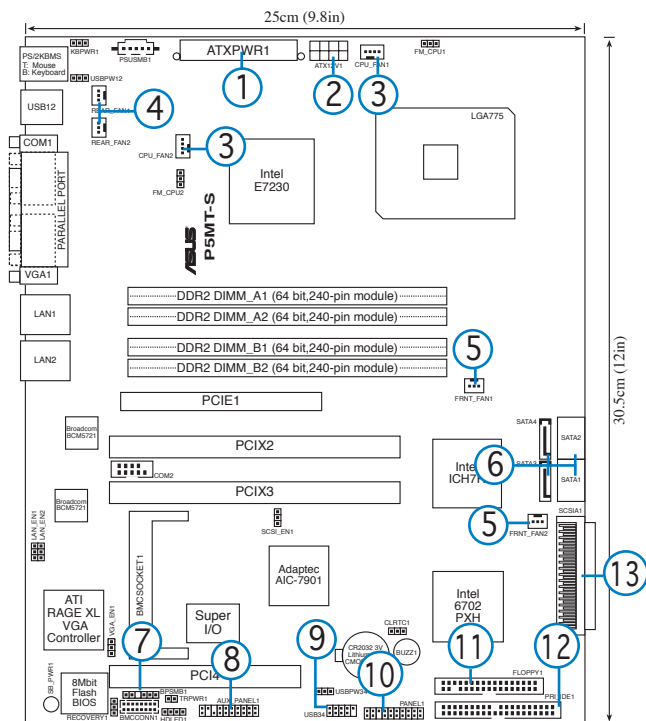

Standard cables connected to the motherboard

- | | |
|--------------------------|--|
| 1. 24-pin ATX power | 7. SMBus connector |
| 2. 4-pin 12V power | 8. Auxiliary panel cable |
| 3. CPU fan 1/2 | 9. Front USB cable |
| 4. Rear fan 1/2 | 10. Front panel cable |
| 5. Front fan 1/2 | 11. Floppy disk drive |
| 6. Serial ATA connectors | 12. Primary IDE cable |
| | 13. SCSI connector
(for PS4 Model only) |

2.9.2 SATA backplane connections (in PA4 model only)

A SATA backplane comes pre-installed in the TS300-E3 PA4 model. The SATA backplane has four 15-pin SATA connectors to support Serial ATA hard disk drives. The backplane design incorporates a hot swap feature to allow easy connection or removal of SATA hard disks. The LED on the backplane connect to the front panel LED to indicate HDD status. See section “1.6 LED information” for details.

Front side

The front side of the SATA backplane faces the front panel when installed. This side includes four SATA connectors for the hot swap drive trays.

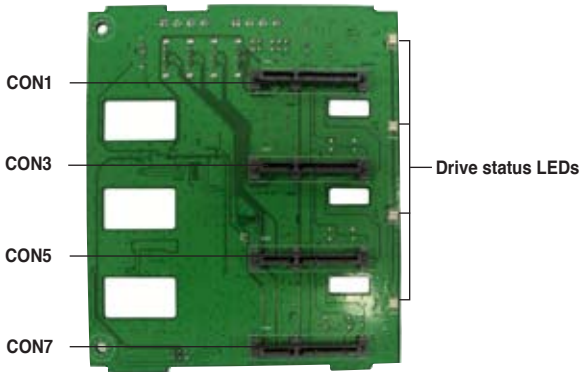

Each SATA connector is labeled (CON1, CON3, CON5, CON7) so you can easily determine their counterpart connectors at the back side of the backplane. Refer to the table for reference.

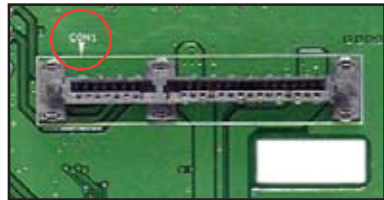

HDD device	Front side connector	Back side connector
HDD 1	CON1	CON2
HDD 2	CON3	CON4
HDD 3	CON5	CON6
HDD 4	CON7	CON8

Back side

The back side of SATA backplane faces the rear panel when installed. This side includes the power connectors, SATA interfaces for the motherboard Serial ATA connectors or the SATA/RAID card, an HDD fan connector, and SMBus connectors.

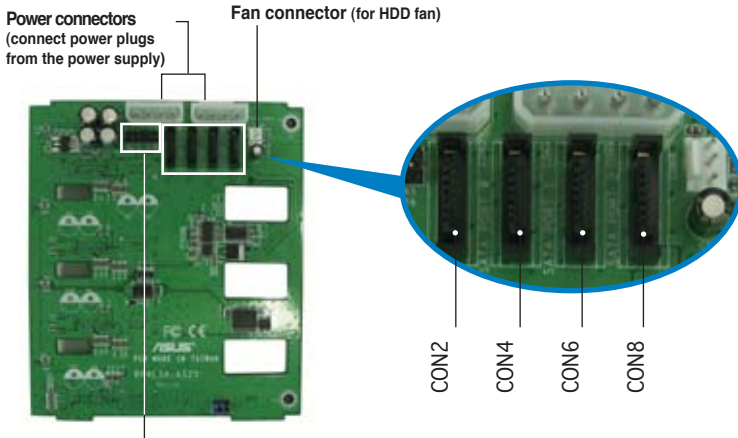

Upper 6-1 pins: SMBus connector
(connects the SMB cable from the BPSMB1 connector on the motherboard)

The back side SATA connectors are attached to the motherboard SATA connectors via the supplied SATA cables. Refer to the illustration below for the location of the SATA connectors. Refer to the table on the right for the default SATA cable connections.

Backplane ID	Connected to (on motherboard)	Controlled by
CON2	SATA1	Intel® ICH7R
CON4	SATA2	Intel® ICH7R
CON6	SATA3	Intel® ICH7R
CON8	SATA4	Intel® ICH7R

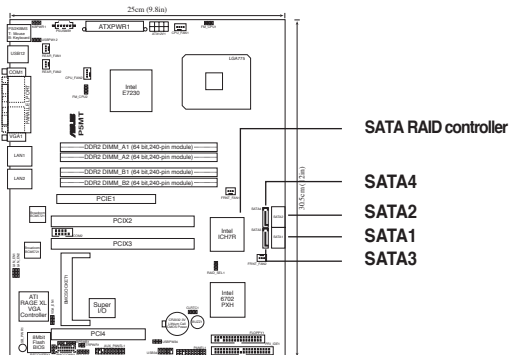

SATA backplane jumper settings and HDD ID assignments

The 6-pin jumper J3 allows you to define your desired SATA configuration. The picture below shows the location of jumper J3 with pins 1-3 and 2-4 shorted.

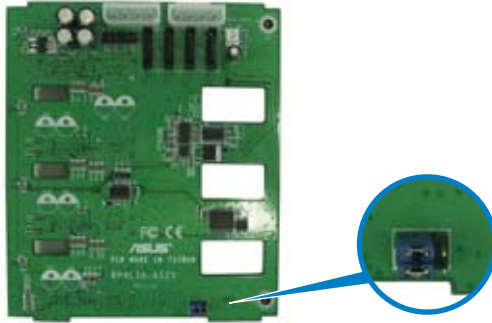

Refer to the table for the jumper settings and the appropriate ID# for each SATA HDD bay.

J3 setting <i>(1-3 shorted, 2-4 shorted)</i>		
Device	SATA ID#	
Drive Bay 1	ID0	
Drive Bay 2	ID1	
Drive Bay 3	ID2	
Drive Bay 4	ID3	

2.9.3 SCSI backplane connections (in PS4 model only)

A SCSI backplane comes pre-installed in the TS300-E3 PS4 model. The SCSI backplane has four 68-pin SCSI connectors to support SCA SCSI hard disks. The backplane design incorporates a hot swap feature to allow easy connection or removal of SCSI hard disks. The LEDs on the backplane connect to the front panel LEDs to indicate HDD access, HDD failure, thermal failure, or fan failure. See section “1.6 LED information.”

Front side

The front side of the SCSI backplane faces the front panel when installed. This side includes four SCSI connectors for the hot swap drive trays.

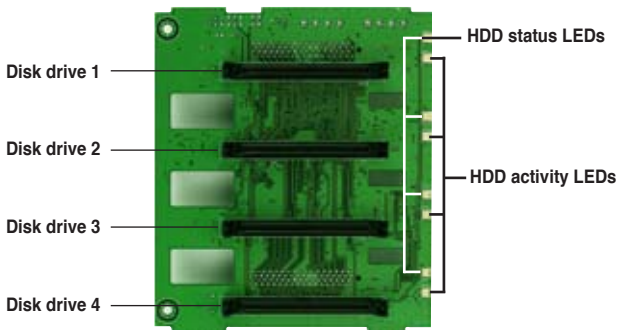

Back side

The back side of SCSI backplane faces the rear panel when installed. This side includes the power connectors, SCSI interfaces for the motherboard SCSI connector or the SCSI/RAID card and terminator, an HDD fan connector, and SMBus connectors.



- the upper SCSI interface of the backplane connects to the motherboard SCSI connector or the SCSI/RAID card
- a SCSI multi-mode terminator (LVD/SE) is connected to the lower SCSI interface of the backplane

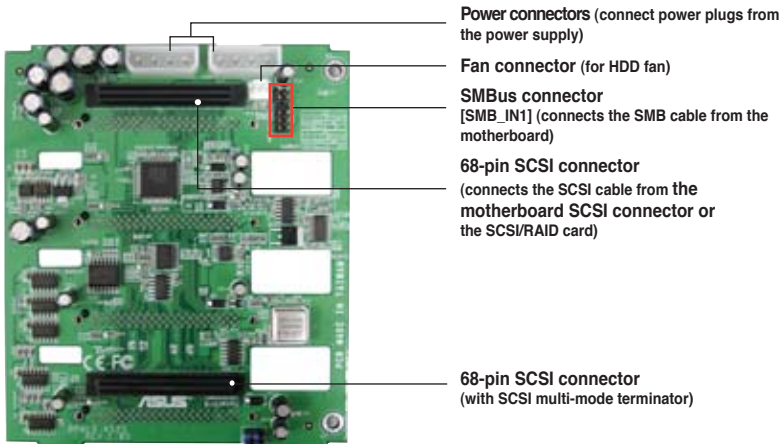

SCSI backplane jumper settings and HDD ID assignments

The 6-pin jumper J1 on each of the SCSI backplanes allows you to define your desired SCSI configuration.

The picture below shows the location of jumper J1 with pins 1-3 and 2-4 shorted.

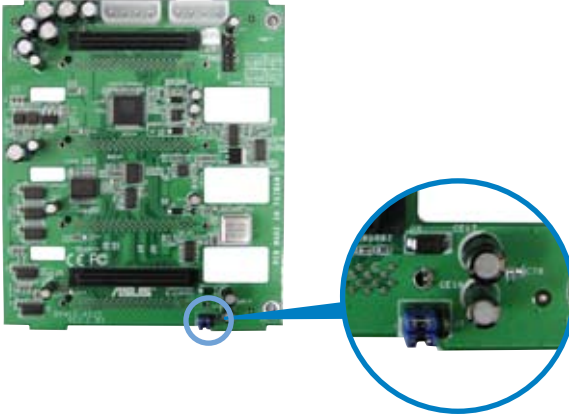

Refer to the following tables for the jumper settings and the appropriate ID# for each SCSI HDD bay.

J1 setting (1-3 shorted, 2-4 shorted)	
Device	SCSI ID#
Drive Bay 1	ID0
Drive Bay 2	ID1
Drive Bay 3	ID2
Drive Bay 4	ID3
GEM SAF-TE	ID15 (SCSI channel-0)

2.10 Removable components

You may need to remove previously installed system components when installing or removing system devices, or when you need to replace defective components. This section tells how to remove the following components:

1. Chassis fan
2. HDD blowers
3. SATA/SCSI backplanes
4. Floppy disk drive module
5. Front I/O board
6. Chassis footpads and roller wheels
7. Power supply unit

2.10.1 Chassis fan

To remove the chassis fan:

1. Unplug the chassis fan cable from the REAR_FAN1 connector on the motherboard.

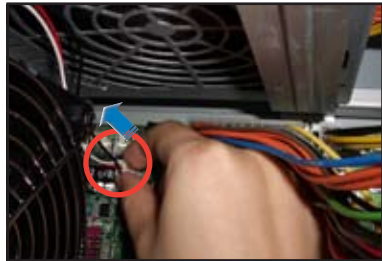

2. Locate the four screws that secure the fan to the chassis.
3. Remove the four screws while carefully supporting the chassis fan with your free hand to prevent it from falling off.
Set the screws aside.

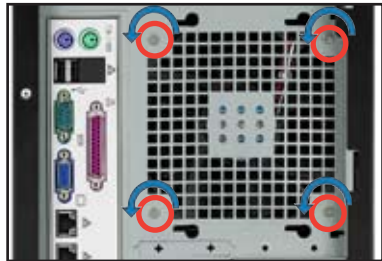

4. Carefully remove the chassis fan.



5. Remove the four screws that secure the metal shroud to the fan. Set the screws aside.

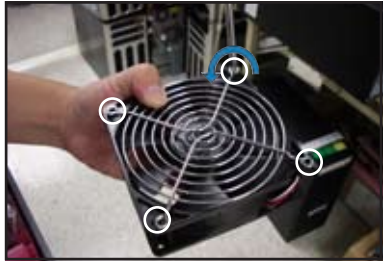

To reinstall the chassis fan:

1. Drive in the four screws you removed earlier into the fan screw holes to secure the metal shroud to the fan.

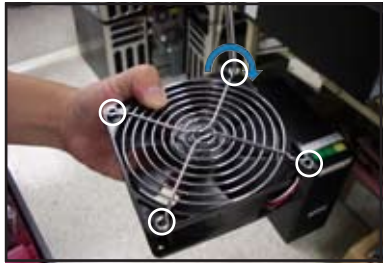

2. Align the chassis fan holes to the screw holes on the chassis.



3. Drive in the four screws you removed earlier to secure the fan to the chassis.

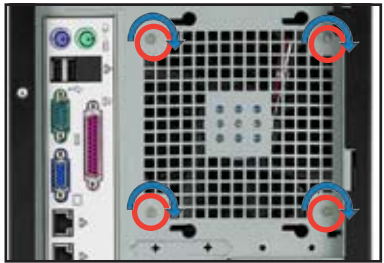

4. Plug the chassis fan cable to the connector on the motherboard.

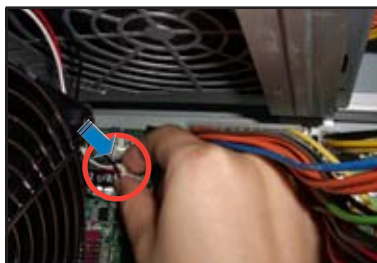

2.10.2 HDD blower

To remove the HDD blower:

1. Remove the side cover. Refer to section 2.10.1 instructions.
2. Disconnect the 3-pin fan cable from the

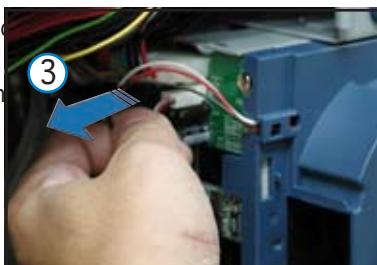

3. Loosen the thumb screw that secures the HDD blower case to the chassis.



4. Firmly grip the blower case as shown, then slide it out of the chassis in the direction of the arrow until the tabs are released from the holes of the HDD cage.



5. Remove the two screws on the blower case using a Phillips screwdriver. Set the screws aside.



6. Remove the blower from the case.



To reinstall the HDD blower:

1. Replace the blower into the case.

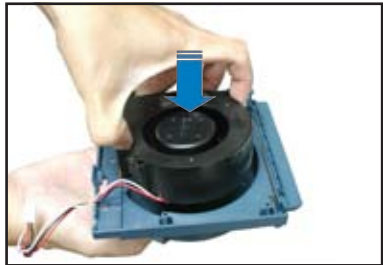

2. Secure the blower to the case with the two screws you removed earlier.



- Slide in the blower case as shown, making sure the tabs fit into the holes on the HDD cage.



- Drive in the thumb screw to secure the HDD blower case.



- Connect the 3-pin fan cable to the fan connector on the backplane.

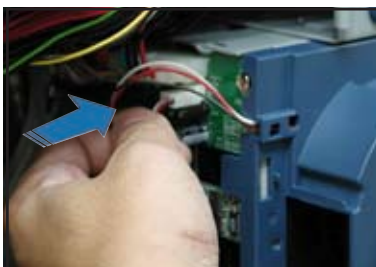

2.10.3 SATA/SCSI backplane

To remove the SATA/SCSI backplane:

1. Remove the HDD blower case. Refer to section “2.10.2 HDD blowers” for instructions.
2. Disconnect all cables from the SATA/SCSI backplane.



When disconnecting a cable, hold and firmly pull the cable plug. DO NOT pull the cable itself. Doing so may damage the cable!



3. From the inner edge, push the backplane outward so that the outer edge protrudes slightly from the slot.
4. From the outer edge, firmly hold the backplane and carefully slide it out.

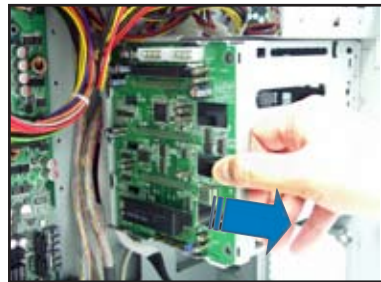

To reinstall a SATA/SCSI backplane:

1. Position the backplane into its slot with the component side facing the rear panel, and the power connectors on top.
2. Align the backplane with the rail-like dents on the slot to ensure that it fits securely.



Rail-like dents

3. Slide the backplane into the slot until it fits. If correctly installed, the outer edge of the backplane aligns with the corner of the drive cage.
4. Connect the appropriate cables to the backplane. Refer to sections “2.9.2 SATA backplane connections” and “2.9.3 SCSI backplane connections” for details.

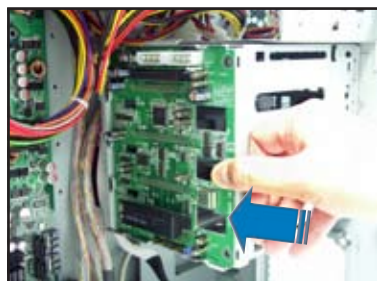

2.10.4 Floppy disk drive



You need to remove the front panel assembly before you can remove the floppy disk drive. Refer to section “2.5.1 Removing the front panel assembly” for instructions.

To remove the floppy disk drive:

1. Remove the screw that secures the drive to the chassis.



2. Carefully pull out the drive from the chassis until you see the cables connected to the drive.



3. Disconnect the floppy disk cable and power cable from the drive to completely release the drive.



To install a floppy disk drive:

1. Position the floppy drive vertically with the eject button on the left side (close to the HDDs).
2. Connect the drive signal cable and power cable.

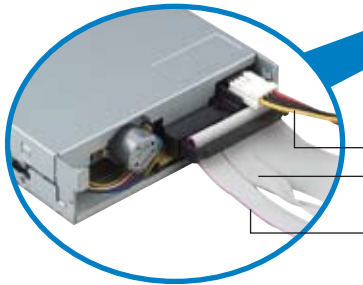

- Floppy drive power cable
- Floppy drive signal cable
- Red stripe to match Pin 1 on the connector

3. Carefully push the drive into the bay until the drive cage fits the front edge of the bay.



4. Secure the drive cage with a screw.



2.10.5 Front I/O board



You need to remove the front panel assembly before you can remove the front I/O board. Refer to section "2.5.1 Removing the front panel assembly" for instructions.

To remove the front I/O board:

1. Remove the screw that secures the front I/O board bracket to the front panel.



2. Carefully pull out the bracket until you see the cables connected to the I/O board.
3. Disconnect all the cables from the I/O board.



4. Remove the screw that secures the I/O board to the bracket.

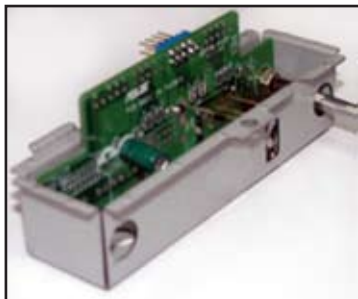

To install the front I/O board:

1. Place the I/O board in the bracket, component side up. Secure the front I/O board to the bracket with a screw.

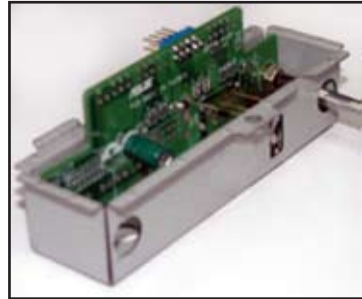

2. Position the I/O board into the bay with the component side to the left (close to the HDDs). Connect the I/O cables to the connectors on the back of the I/O board.

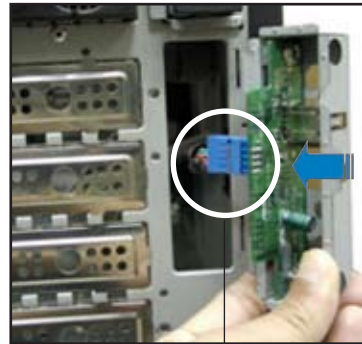

USB 2.0 connector

3. Insert the I/O board into the bay until the bracket fits the front edge of the bay.
4. Secure the I/O board bracket with a screw.



2.10.6 Chassis footpads and roller wheels

The barebone server system is shipped with four footpads attached to the bottom of the chassis for stability. You need to remove these footpads if:

- if you want to replace the footpads with the bundled roller wheels
- you wish to install the system to a rack

(Refer to “Chapter 3 Installation options” of this user guide, and to the “Rackmount Kit” user guide for instructions)

To remove the footpads:

1. Lay the system chassis on its side.
2. Use a flat screwdriver to flip out the top layer of a footpad.

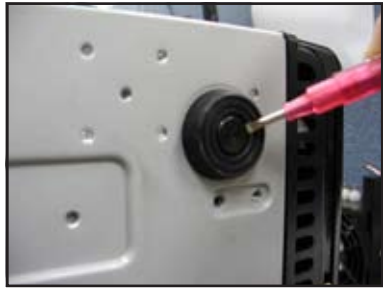

3. Remove the footpad by rotating it counterclockwise.



4. Repeat steps 2 and 3 to remove the other three footpads.

For convenient transport, install the roller wheels the came with the system package. Each wheel has a brake lock to stabilize the chassis in place.

To install the chassis wheels:

1. Lay the chassis in its side.
2. Locate the designated screw holes for each of the four wheel sets. Take note of the numbers alongside each hole when placing screws.

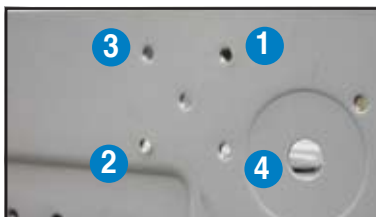

3. Secure each wheel to the bottom of the chassis using four screws.
4. Repeat steps 2 and 3 to install the other three wheels.



Remove the chassis roller wheels if you wish to mount the system to a rack.

To remove the chassis wheels:

1. Lay the system chassis on its side.
2. Use a Phillips screwdriver to remove the screws that secure the wheels to the bottom of the chassis.
3. Repeat step 2 to remove the other three roller wheels.



2.10.7 Power supply unit

Refer to this section when removing or installing a power supply unit to the barebone system.



You **MUST** disconnect all power cable plugs from the motherboard and other installed devices before removing the power supply unit.

The picture below shows the motherboard and device connectors where the power plugs are connected. Refer to the Appendix at the end of this document for the power supply specifications.

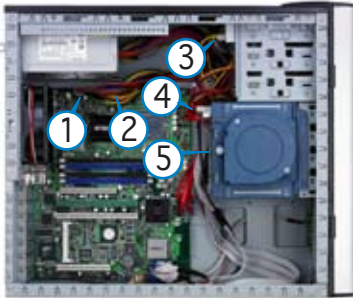

Model PA4

1. 24-pin ATX (*motherboard power connector*)
2. 4-pin +12V (*motherboard power connector, hidden behind the cables*)
3. 4-pin plug (*optical drive*)
4. 2 x 4-pin plugs (*SATA backplane*)
5. 4-pin plug (*floppy disk drive, hidden behind the backplane*)

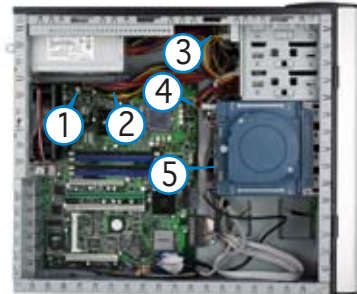

Model PS4

1. 24-pin ATX (*motherboard power connector*)
2. 4-pin +12V (*motherboard power connector, hidden behind the cables*)
3. 4-pin plug (*optical drive*)
4. 2 x 4-pin plugs (*SCSI backplane*)
5. 4-pin plug (*floppy disk drive, hidden behind the backplane*)



Make sure to unplug ALL power cables from the system devices before removing the power supply unit.

To remove the power supply unit (PSU):

1. Remove the chassis cover. Refer to section “2.1.1 Removing the side cover.”
2. Remove the front panel assembly. Refer to section “2.5.1 Removing the front panel assembly.”
3. Lay the chassis on a flat, stable surface.
4. Locate the four screws on the rear panel. Remove the screws and set them aside.

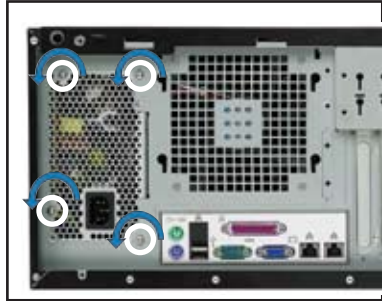

5. Locate and remove the screws that secure the PSU bracket to the chassis.

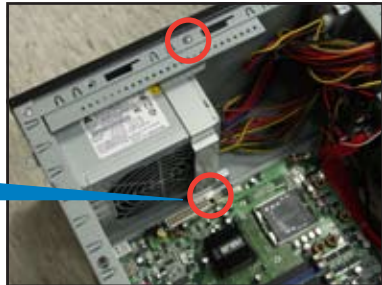

6. Slide the bracket in the direction of the arrow and remove it from the chassis.



7. Carefully slide the PSU in the direction of the arrow until it disengages from the chassis.



To reinstall the power supply unit:

1. Carefully slide the PSU in the direction of the arrow.



2. Secure the PSU to the chassis with the four screws you removed earlier.

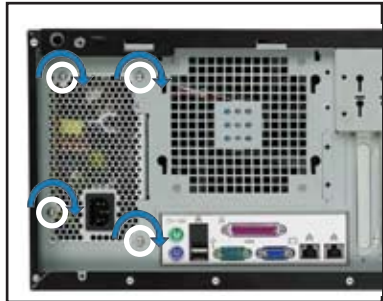

3. Slide in the PSU bracket.



4. Align the screw holes.



5. Secure the bracket with screws you removed earlier.

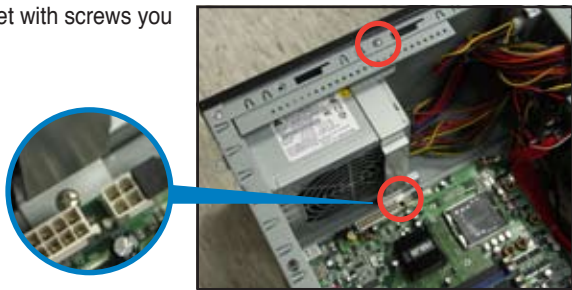

Chapter 3

This chapter describes how to install optional components into the barebone server.





The items required for the optional configurations described in this chapter are not included in the standard barebone system package. These items are purchased separately.

Preparing the system for rack mounting

Removing the footpads or roller wheels

Refer to section “2.10.6 Chassis footpads and roller wheels” for instructions on removing the footpads or roller wheels.

Removing the top cover

To remove the top cover:

1. Remove the chassis cover. Refer to section “2.1.1 Removing the side cover.”
2. Remove the front panel assembly. Refer to section “2.5.1 Removing the front panel assembly.”
3. Carefully slide out the protruding portion of the top cover as shown.



4. Locate two round mylars on top cover.
5. Carefully remove each mylar using a sharp, flat object such as the edge of a cutter.



Attaching the rack rails

Refer to the installation guide that came with the Rackmount Rail Kit for instructions on how to attach the rails and on the barebone server system and the corresponding rails on the industrial rack.



We recommend that you allot at least 1U space above the server system to ensure optimal thermal performance.

Chapter 4

This chapter gives information about the motherboard that comes with the server. This chapter includes the motherboard layout, jumper settings, and connector locations.



4.1 Motherboard layouts

P5MT model

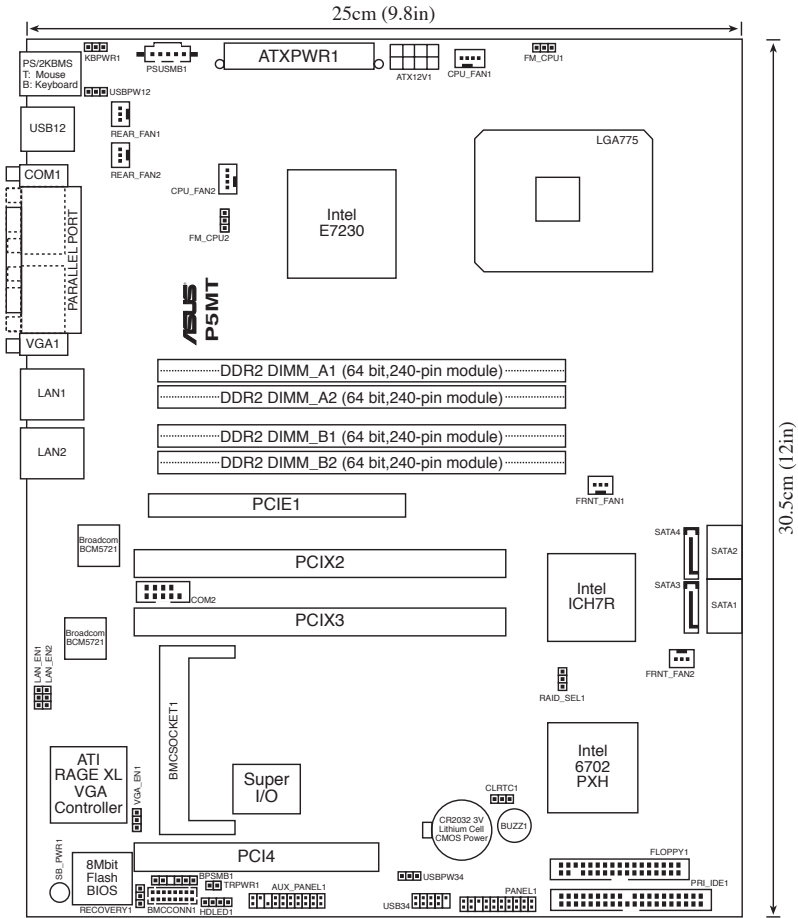

Layout contents

Jumpers		Page
1.	Clear RTC RAM (CLRRTC1)	4-5
2.	CPU fan pin selection (3-pin FM_CPU1, FM_CPU2)	4-6
3.	USB device wake-up (3-pin USBPW12, USBPW34)	4-6
4.	Keyboard power (3-pin KBPWR1)	4-7
5.	VGA controller setting (3-pin VGA_EN1)	4-7
6.	Gigabit LAN controller setting (3-pin LAN_EN1; LAN_EN2)	4-8
7.	RAID controller selection (3-pin RAID_SEL1) (P5MT model only)	4-8
8.	SCSI controller setting (3-pin SCSI_EN1) (P5MT-S model only)	4-9
9.	Force BIOS recovery setting (3-pin RECOVERY1)	4-9

Internal connectors		Page
1.	Floppy disk drive connector (34-1 pin FLOPPY1)	4-10
2.	Primary IDE connectors (40-1 pin PRI_IDE1)	4-10
3.	Serial ATA connectors (7-pin SATA1, SATA2, SATA3, SATA4)	4-11
4.	Hard disk activity LED connector (4-pin HDLED1)	4-12
5.	USB connector (10-1 pin USB34)	4-12
6.	Ultra320 SCSI connectors (one 68-pin SCSI A1) (P5MT-S model only)	4-13
7.	Serial port connector (10-1 pin COM2)	4-14
8.	BMC connector (16-pin BMCCONN1)	4-14
9.	Ambient thermal sensor (2-pin TRPWR1)	4-14
10.	CPU and system fan connectors (3-pin CPU_FAN1/2, REAR_FAN1/2, FRNT_FAN1/2)	4-15
11.	Backplane SMBus connector (6-1 pin BPSMB1)	4-15
12.	Power supply SMBus connector (5-pin PSUSMB1)	4-16
13.	ATX power connectors (24-pin ATXPWR1, 8-pin ATX12V2)	4-16
14.	System panel connector (20-pin PANEL1)	4-17
15.	Auxiliary panel connector (20-pin AUX_PANEL1)	4-18

4.2 Jumpers



The grayed out components in the illustrations may not be present in certain models.

1. Clear RTC RAM (CLRRTC1)

This jumper allows you to clear the Real Time Clock (RTC) RAM in CMOS. You can clear the CMOS memory of date, time, and system setup parameters by erasing the CMOS RTC RAM data. The onboard button cell battery powers the RAM data in CMOS, which include system setup information such as system passwords.

To erase the RTC RAM:

1. Turn OFF the computer and unplug the power cord.
2. Remove the onboard battery.
3. Move the jumper cap from pins 1-2 (default) to pins 2-3. Keep the cap on pins 2-3 for about 5~10 seconds, then move the cap back to pins 1-2.
4. Re-install the battery.
5. Plug the power cord and turn ON the computer.
6. Hold down the key during the boot process and enter BIOS setup to re-enter data.



Except when clearing the RTC RAM, never remove the cap on CLRRTC jumper default position. Removing the cap will cause system boot failure!

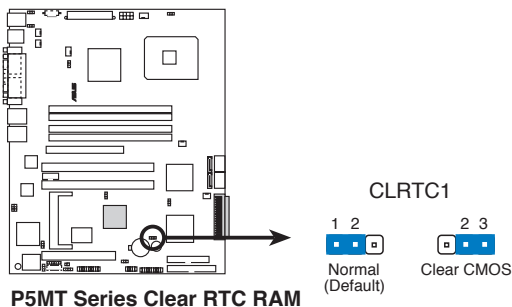

2. CPU fan pin selection (3-pin FM_CPU1, FM_CPU2)

These jumpers allow you to connect either a 3-pin or a 4-pin fan cable plug to the CPU fan connectors (CPU_FAN1, CPU_FAN2). Set these jumpers to pins 1-2 if you are using a 3-pin fan cable plug, or to pins 2-3 if you are using a 4-pin plug.

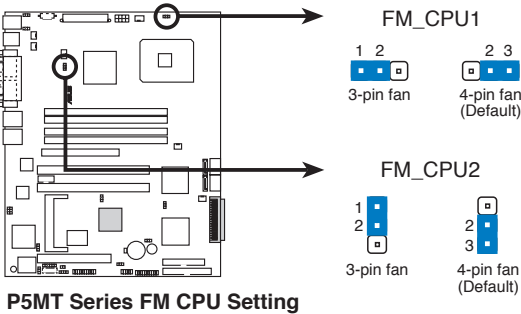

3. USB device wake-up (3-pin USBPW12, USBPW34)

Set these jumpers to +5V to wake up the computer from S1 sleep mode (CPU stopped, DRAM refreshed, system running in low power mode) using the connected USB devices. Set to +5VSB to wake up from S4 sleep mode (no power to CPU, DRAM in slow refresh, power supply in reduced power mode).

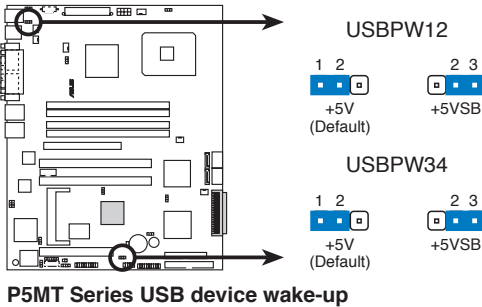

- The USB device wake-up feature requires a power supply that can provide 500mA on the +5VSB lead for each USB port; otherwise, the system would not power up.
- If you are using Windows 2000, you need to install Service Pack 4 to wake up the system from S4 sleep mode.
- The total current consumed must NOT exceed the power supply capability (+5VSB) whether under normal condition or in sleep mode.

4. Keyboard/Mouse power (3-pin KBPWR1)

This jumper allows you to enable or disable the keyboard/mouse wake-up feature. Set this jumper to pins 2-3 (+5VSB) to wake up the computer when you press any key on the keyboard (the default is the Space Bar) or click the mouse. This feature requires an ATX power supply that can supply at least 1A on the +5VSB lead, and a corresponding setting in the BIOS.

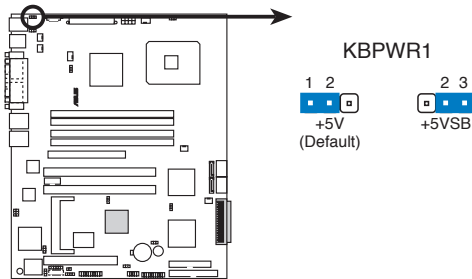

P5MT Series Keyboard power setting

5. VGA controller setting (3-pin VGA_EN1)

These jumpers allow you to enable or disable the onboard ATI® RAGE-XL PCI VGA controller. Set to pins 1-2 to activate the VGA feature.

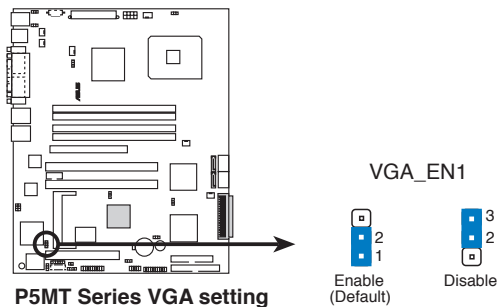

P5MT Series VGA setting

6. Gigabit LAN controller setting (3-pin LAN_EN1, LAN_EN2)

These jumpers allow you to enable or disable the onboard Broadcom® BCM5721 Gigabit LAN1 or LAN2 controller. Set to pins 1-2 to activate the Gigabit LAN controller.

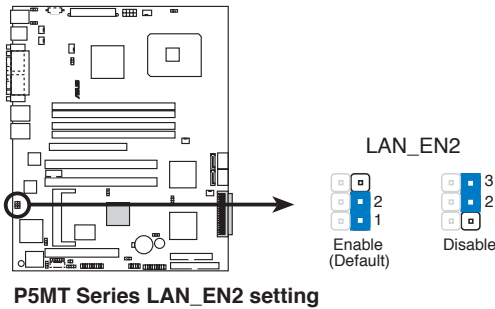
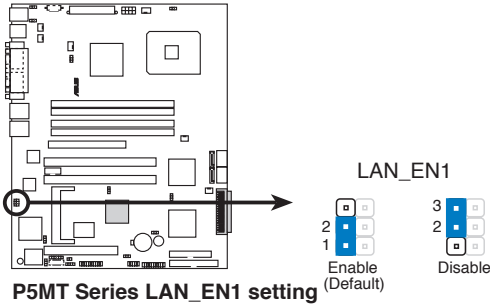

7. RAID controller selection (3-pin RAID_SEL1) [P5MT model only]

This jumper allows you to select the RAID configuration utility to use when you create disk arrays. Place the jumper caps over pins 1-2 if you want to use the LSI Logic Embedded SATA RAID Setup Utility (default); otherwise, place the jumper caps to pins 2-3 to use the Intel® Matrix Storage Manager.

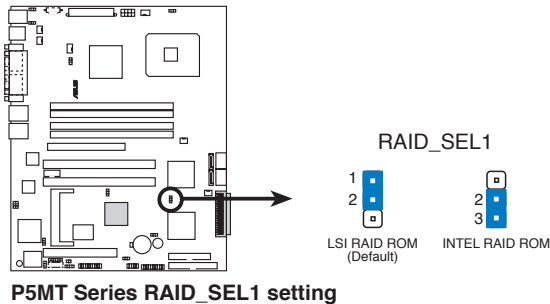

8. SCSI controller setting (3-pin SCSI_EN1) [P5MT-S model only]

This jumper allows you to enable or disable the onboard Adaptec AIC-7901 PCI-X SCSI controller. Set to pins 1-2 to activate the SCSI feature, and support RAID configurations.

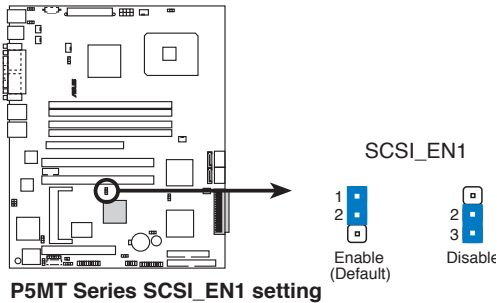

9. Force BIOS recovery setting (3-pin RECOVERY1)

This jumper allows you to quickly update or recover the BIOS settings when it becomes corrupted.

To update the BIOS:

1. Prepare a floppy disk that contains the latest BIOS for the motherboard (xxxx-xxx.ROM) and the AFUDOS.EXE utility.
2. Set the jumper to pins 2-3.
3. Insert the floppy disk then turn on the system to update the BIOS.
4. Shut down the system.
5. Set the jumper back to pins 1-2.
6. Turn on the system.

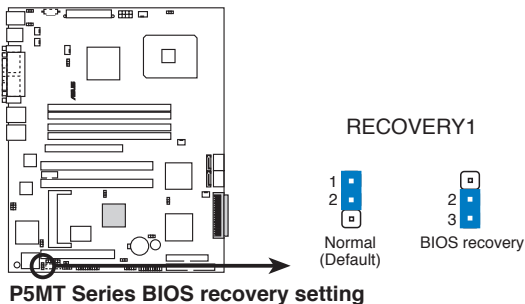

4.3 Internal connectors

1. Floppy disk drive connector (34-1 pin FLOPPY1)

This connector is for the provided floppy disk drive (FDD) signal cable. Insert one end of the cable to this connector, then connect the other end to the signal connector at the back of the floppy disk drive.



Pin 5 on the connector is removed to prevent incorrect cable connection when using a FDD cable with a covered Pin 5.

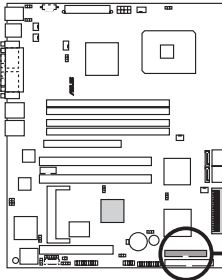

P5MT Series Floppy disk drive connector



NOTE: Orient the red markings on the floppy ribbon cable to PIN 1.

2. Primary IDE connector (40-1 pin PRI_IDE1)

This connector is for an Ultra ATA100/66/33 signal cable. The Ultra ATA 100/66/33 signal cable has three connectors: a blue connector for the primary IDE connector on the motherboard, a black connector for an Ultra ATA 100/66/33 IDE slave device (optical drive/hard disk drive), and a gray connector for an Ultra ATA 100/66/33 IDE master device (hard disk drive). If you install two hard disk drives, you must configure the second drive as a slave device by setting its jumper accordingly. Refer to the hard disk documentation for the jumper settings.



- Pin 20 on the IDE connector is removed to match the covered hole on the Ultra ATA cable connector. This prevents incorrect insertion when you connect the IDE cable.
- Use the 80-conductor IDE cable for Ultra ATA 100/66/33 IDE devices.

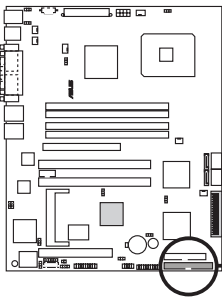

P5MT Series IDE connector



NOTE: Orient the red markings (usually zigzag) on the IDE ribbon cable to PIN 1.

3. Serial ATA connectors (7-pin SATA1, SATA2, SATA3, SATA4)

These connectors are for the Serial ATA signal cables for Serial ATA hard disk drives.

For P5MT model only: If you installed Serial ATA hard disk drives, you can create a RAID 0, RAID 1, RAID 0+1, and software RAID 5 configuration using the Intel® Matrix Storage Technology or RAID 0, RAID 1 and RAID 0+1 configuration using the LSI MegaRAID® utility embedded on the Intel® ICH7R Southbridge.



These connectors are set IDE mode by default. In IDE mode, you can connect Serial ATA boot/data hard disk drives to these connectors. If you intend to create a Serial ATA RAID set using these connectors, set the Configure SATA as item in the BIOS to [RAID]. See section "4.3.4 IDE Configuration" for details.

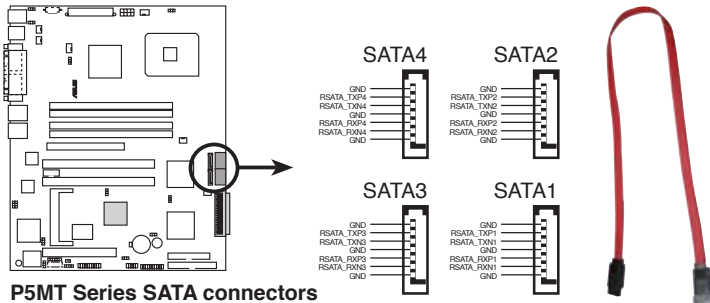

P5MT Series SATA connectors



Important notes on Serial ATA

- You must install Windows® 2000 Service Pack 4 or Windows® 2003 before using Serial ATA hard disk drives. The Serial ATA RAID feature (RAID 0/RAID 1) is available only if you are using Windows® 2000/2003.
- Use only two Serial ATA RAID connectors for each RAID 0 or RAID 1 set.
- When using the connectors in IDE mode, connect the primary (boot) hard disk drive to the SATA1 or SATA2 connector. Refer to the table below for the recommended SATA hard disk drive connections.

Serial ATA hard disk drive connection

Connector	Setting	Use
SATA1/SATA2	Master	Boot disk
SATA3/SATA4	Slave	Data disk

4. Hard disk activity LED connector (4-pin HDLED1)

This connector supplies power to the hard disk activity LED. The read or write activities of any device connected to the SCSI connectors or the SATA connectors cause this LED to light up.

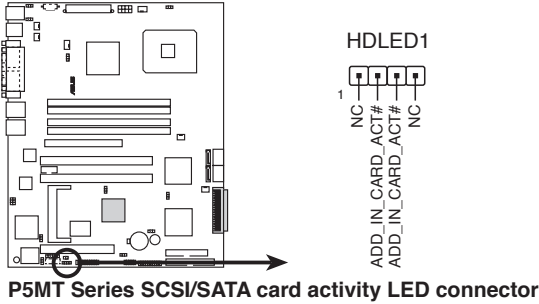

5. USB connector (10-1 pin USB34)

This connector is for USB 2.0 ports. Connect the USB module cable to this connector, then install the module to a slot opening at the back of the system chassis. This USB connector complies with USB 2.0 specification that supports up to 480 Mbps connection speed.

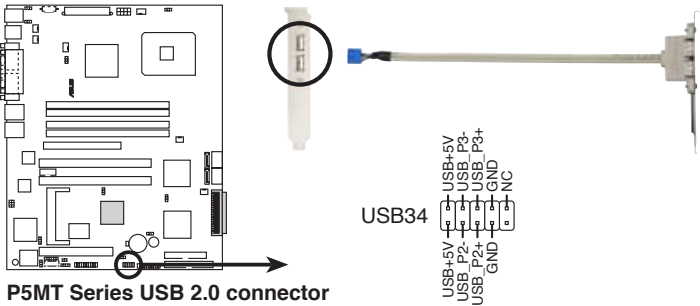

The USB port module is purchased separately.

6. Ultra320 SCSI connectors (one 68-pin SCSI A1)

[P5MT-S model only]

This motherboard comes with the Adaptec AIC-7901 PCI-X SCSI U320 controller that supports one 68-Pin Ultra320 SCSI connector. The SCSI channel can support a maximum of 15 SCSI devices as specified by Ultra320 standards.

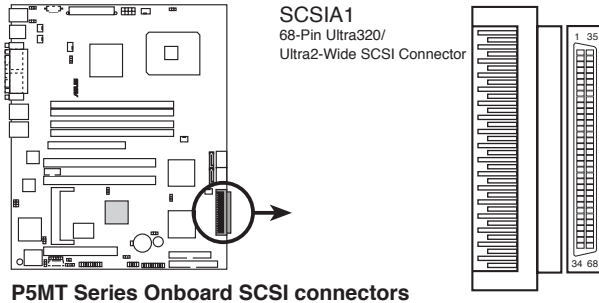

SCSI connection notes

This motherboard has a 68-Pin Ultra320 SCSI connector.

The onboard SCSI chipset incorporates an advanced multimode I/O cell that supports both single-ended (SE), Ultra2, Ultra160, and Ultra320 devices. With Ultra320 devices, the SCSI bus platform performs at full Ultra320 speeds (up to 320MB/s) and extended cabling 12m (or 25m in a point-to-point configuration). When an SE device is attached, the bus defaults to an SE speed and 1.5m cable length.



Connect SCSI devices as specified. A SCSI channel should have only one type of SCSI standard (e.g. Ultra320, Ultra160, Ultra2, Ultra-Wide). Mixing SCSI devices on a single channel decreases performance of the slower device.

7. Serial port connector (10-1 pin COM2)

This connector is for a serial (COM) port. Connect the serial port module cable to this connector, then install the module to a slot opening at the back of the system chassis. The serial port module is purchased separately.

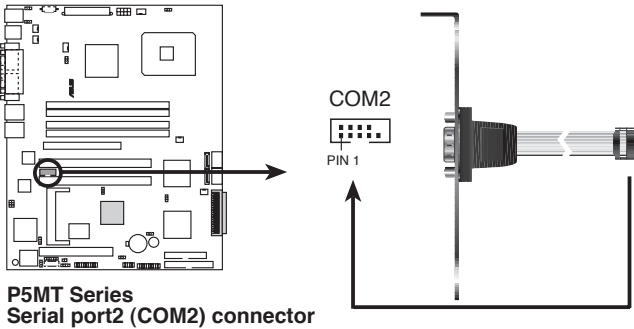

**P5MT Series
Serial port2 (COM2) connector**

8. BMC connector (16-pin BMCCONN1)

This connector is for the ASUS server management card, if available.

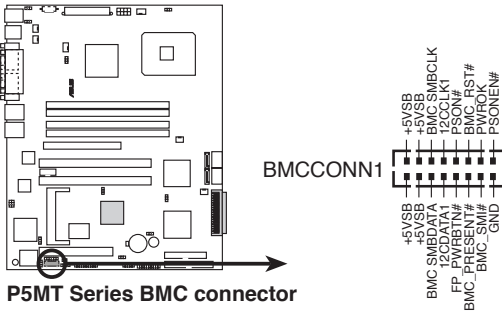

P5MT Series BMC connector

9. Ambient thermal sensor (2-pin TRPWR1)

If you want additional thermal monitoring, connect the thermal sensor cable with thermistor (of 1°K or at 25°C, B=3435) to this connector.

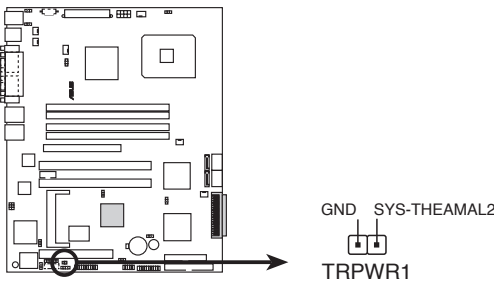

P5MT Series TRPWR connector

10. CPU and system fan connectors (3-pin CPU_FAN1/2, REAR_FAN1/2, FRNT_FAN1/2)

The fan connectors support cooling fans of 350 mA ~ 740 mA (8.88 W max.) or a total of 2.1 A ~ 4.44 A (53.28 W max.) at +12V. Connect the fan cables to the fan connectors on the motherboard, making sure that the black wire of each cable matches the ground pin of the connector.



Do not forget to connect the fan cables to the fan connectors. Insufficient air flow inside the system may damage the motherboard components. These are not jumpers! Do not place jumper caps on the fan connectors!

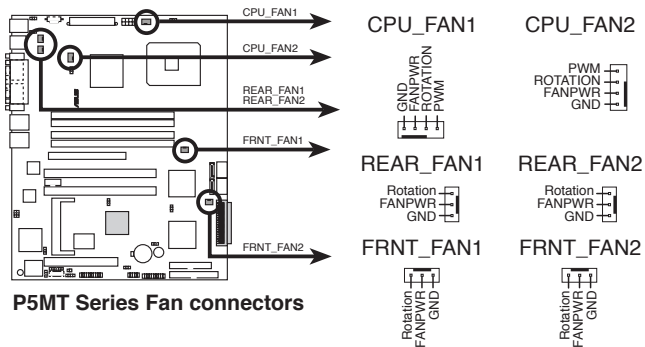

11. Backplane SMBus connector (6-1 pin BPSMB1)

This connector allows you to connect SMBus (System Management Bus) devices. Devices communicate with an SMBus host and/or other SMBus devices using the SMBus interface.

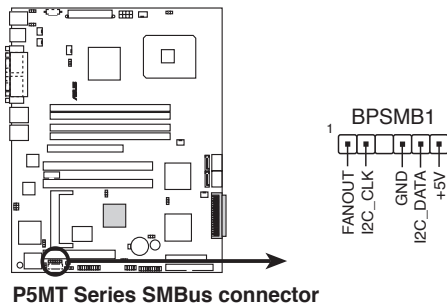

12. Power supply SMBus connector (5-pin PSUSMB1)

This connector is for the power supply SMB cable, if your power supply supports the SMBus function.

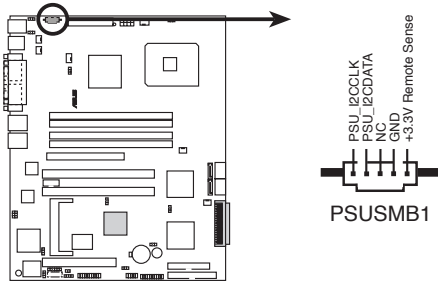

P5MT Series Power supply SMBus connector

13. SSI power connectors (24-pin ATXPWR1, 8-pin ATX12V2)

These connectors are for SSI power supply plugs. The power supply plugs are designed to fit these connectors in only one orientation. Find the proper orientation and push down firmly until the connectors completely fit.



- Use of an SSI 12 V Specification 2.0-compliant power supply unit (PSU) that provides a minimum power of 450 W is recommended for a fully-configured system.
- By default, four ATX12V2 connector pins are covered to prevent incorrect insertion of a 4-pin ATX +12V power plug. Remove this cover when using a PSU with an 8-pin ATX +12V power plug.
- Do not forget to connect the 4-pin or 8-pin ATX +12 V power plug; otherwise, the system will not boot up.
- Use of a PSU with a higher power output is recommended when configuring a system with more power consuming devices. The system may become unstable or may not boot up if the power is inadequate.
- You must install a PSU with a higher power rating if you intend to install additional devices.

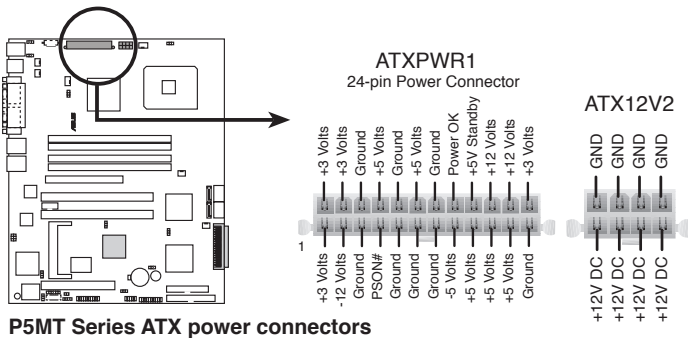

P5MT Series ATX power connectors

14. System panel connector (20-pin PANEL1)

This connector supports several chassis-mounted functions.

- **System power LED (Green 3-pin PLED)**

This 3-pin connector is for the system power LED. Connect the chassis power LED cable to this connector. The system power LED lights up when you turn on the system power, and blinks when the system is in sleep mode.

- **Hard disk drive activity LED (Red 2-pin IDE_LED)**

This 2-pin connector is for the HDD Activity LED. Connect the HDD Activity LED cable to this connector. The IDE LED lights up or flashes when data is read from or written to the HDD.

- **System warning speaker (Orange 4-pin SPEAKER)**

This 4-pin connector is for the chassis-mounted system warning speaker. The speaker allows you to hear system beeps and warnings.

- **ATX power button/soft-off button (Light Green 2-pin PWRSW)**

This connector is for the system power button. Pressing the power button turns the system on or puts the system in sleep or soft-off mode depending on the BIOS settings. Pressing the power switch for more than four seconds while the system is ON turns the system OFF.

- **Reset button (Blue 2-pin RESET)**

This 2-pin connector is for the chassis-mounted reset button for system reboot without turning off the system power.

- **Message LED (Brown 2-pin MLED)**

This connector is for the message LED cable that connects to the front panel message LED. The message LED indicates the booting status. The LED blinks when the system is in the boot process until the operating system is loaded.

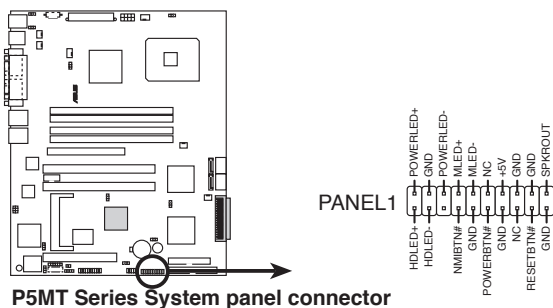

The system panel connector is color-coded for easy connection.

15. Auxiliary panel connector (20-pin AUX_PANEL1)

This connector is for additional front panel features including front panel SMB, locator LED and switch, chassis intrusion, and LAN LEDs.

- **Front panel SMB (6-1 pin FPSMB)**
These leads connect the front panel SMBus cable.
- **LAN activity LED (2-pin LAN1_LED, LAN2_LED)**
These leads are for Gigabit LAN activity LEDs on the front panel.
- **Chassis intrusion (2-pin CHASSIS)**
These leads are for the intrusion detection feature for chassis with intrusion sensor or microswitch. When you remove any chassis component, the sensor triggers and sends a high-level signal to these leads to record a chassis intrusion event.
- **Locator LED (6-pin LOCATOR)**
These leads are for the locator switch and LED on the front panel.

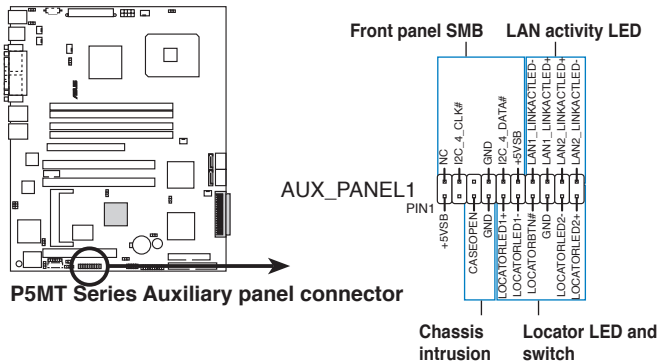

Chapter 5

This chapter tells how to change system settings through the BIOS Setup menus and describes the BIOS parameters.



5.1 Managing and updating your BIOS

The following utilities allow you to manage and update the motherboard Basic Input/Output System (BIOS) setup.

1. **ASUS AFUDOS** (Updates the BIOS in DOS mode using a bootable floppy disk.)
2. **ASUS CrashFree BIOS 2** (Updates the BIOS using a bootable floppy disk or the motherboard support CD when the BIOS file fails or gets corrupted.)
3. **ASUS Update** (Updates the BIOS in Windows® environment.)

Refer to the corresponding sections for details on these utilities.



Save a copy of the original motherboard BIOS file to a bootable floppy disk in case you need to restore the BIOS in the future. Copy the original motherboard BIOS using the ASUS Update or AFUDOS utilities.

5.1.1 Creating a bootable floppy disk

1. Do either one of the following to create a bootable floppy disk.

DOS environment

- a. Insert a 1.44MB floppy disk into the drive.
- b. At the DOS prompt, type `format A: /S` then press <Enter>.

Windows® XP environment

- a. Insert a 1.44 MB floppy disk to the floppy disk drive.
 - b. Click Start from the Windows® desktop, then select My Computer.
 - c. Select the 3 1/2 Floppy Drive icon.
 - d. Click File from the menu, then select Format. A Format 3 1/2 Floppy Disk window appears.
 - e. Windows® XP users: Select Create an MS-DOS startup disk from the format options field, then click Start.
2. Copy the original or the latest motherboard BIOS file to the bootable floppy disk.

5.1.2 AFUDOS utility

The AFUDOS utility allows you to update the BIOS file in DOS environment using a bootable floppy disk with the updated BIOS file. This utility also allows you to copy the current BIOS file that you can use as backup when the BIOS fails or gets corrupted during the updating process.

Copying the current BIOS

To copy the current BIOS file using the AFUDOS utility:



- Make sure that the floppy disk is not write-protected and has at least 1024 KB free space to save the file.
- The succeeding BIOS screens are for reference only. The actual BIOS screen displays may not be the same as shown.

1. Copy the AFUDOS utility (afudos.exe) from the motherboard support CD to the bootable floppy disk you created earlier.
2. Boot the system in DOS mode, then at the prompt type:

```
afudos /o[filename]
```

where the [filename] is any user-assigned filename not more than eight alphanumeric characters for the main filename and three alphanumeric characters for the extension name.

```
A:\>afudos /oOLDBIOS1.rom
```

Main filename Extension name

3. Press <Enter>. The utility copies the current BIOS file to the floppy disk.

```
A:\>afudos /oOLDBIOS1.rom
AMI Firmware Update Utility - Version 1.19(ASUS V2.07(03.11.24BB))
Copyright (C) 2002 American Megatrends, Inc. All rights reserved.
Reading flash ..... done
Write to file..... ok
A:\>
```

The utility returns to the DOS prompt after copying the current BIOS file.

Updating the BIOS file

To update the BIOS file using the AFUDOS utility:

1. Visit the ASUS website (www.asus.com) and download the latest BIOS file for the motherboard. Save the BIOS file to a bootable floppy disk.



Write the BIOS filename on a piece of paper. You need to type the exact BIOS filename at the DOS prompt.

2. Copy the AFUDOS utility (afudos.exe) from the motherboard support CD to the bootable floppy disk you created earlier.
3. Boot the system in DOS mode, then at the prompt type:

```
afudos /i[filename]
```

where [filename] is the latest or the original BIOS file on the bootable floppy disk.

```
A:\>afudos /iP5MT.rom
```



Use the appropriate BIOS file depending on your motherboard model (e.g. **P5MT.ROM** or **P5MTS.ROM**)

4. The utility verifies the file and starts updating the BIOS.

```
A:\>afudos /iP5MT.ROM
AMI Firmware Update Utility - Version 1.19(ASUS V2.07(03.11.24BB))
Copyright (C) 2002 American Megatrends, Inc. All rights reserved.

WARNING!! Do not turn off power during flash BIOS
Reading file ..... done
Reading flash ..... done

Advance Check .....
Erasing flash ..... done
Writing flash ..... 0x0008CC00 (9%)
```



Do not shut down or reset the system while updating the BIOS to prevent system boot failure!

5. The utility returns to the DOS prompt after the BIOS update process is completed. Reboot the system from the hard disk drive.

```
A:\>afudos /iP5MT.ROM
AMI Firmware Update Utility - Version 1.19(ASUS V2.07(03.11.24BB))
Copyright (C) 2002 American Megatrends, Inc. All rights reserved.

WARNING!! Do not turn off power during flash BIOS
Reading file ..... done
Reading flash ..... done

Advance Check .....
Erasing flash ..... done
Writing flash ..... done
Verifying flash .... done

Please restart your computer

A:\>
```

5.1.3 ASUS CrashFree BIOS 2 utility

The ASUS CrashFree BIOS 2 is an auto recovery tool that allows you to restore the BIOS file when it fails or gets corrupted during the updating process. You can update a corrupted BIOS file using the motherboard support CD or the floppy disk that contains the updated BIOS file.



- Prepare the motherboard support CD or the floppy disk containing the updated motherboard BIOS before using this utility.
- Make sure that you rename the original or updated BIOS file in the floppy disk according to the exact name of your motherboard, e.g. **P5MT.ROM** or **P5MTS.ROM**.

Recovering the BIOS from a floppy disk

To recover the BIOS from a floppy disk:

1. Turn on the system.
2. Insert the floppy disk with the original or updated BIOS file to the floppy disk drive.
3. The utility displays the following message and automatically checks the floppy disk for the original or updated BIOS file.

```
Bad BIOS checksum. Starting BIOS recovery...
Checking for floppy...
```

When found, the utility reads the BIOS file and starts flashing the corrupted BIOS file.

```
Bad BIOS checksum. Starting BIOS recovery...
Checking for floppy...
Floppy found!
Reading file "P5MT.ROM". Completed.
Start flashing...
```



DO NOT shut down or reset the system while updating the BIOS! Doing so can cause system boot failure!

4. Restart the system after the utility completes the updating process.

Recovering the BIOS from the support CD

To recover the BIOS from the support CD:

1. Remove any floppy disk from the floppy disk drive, then turn on the system.
2. Insert the support CD to the optical drive.
3. The utility displays the following message and automatically checks the floppy disk for the original or updated BIOS file.

```
Bad BIOS checksum. Starting BIOS recovery...
Checking for floppy...
```

When no floppy disk is found, the utility automatically checks the optical drive for the original or updated BIOS file. The utility then updates the corrupted BIOS file.

```
Bad BIOS checksum. Starting BIOS recovery...
Checking for floppy...
Floppy not found!
Checking for CD-ROM...
CD-ROM found!
Reading file "P5MT.ROM". Completed.
Start flashing...
```



DO NOT shut down or reset the system while updating the BIOS! Doing so can cause system boot failure!

4. Restart the system after the utility completes the updating process.



The recovered BIOS may not be the latest BIOS version for this motherboard. Visit the ASUS website (www.asus.com) to download the latest BIOS file.

5.1.4 ASUS Update utility

The ASUS Update is a utility that allows you to manage, save, and update the motherboard BIOS in Windows® environment. The ASUS Update utility allows you to:

- Save the current BIOS file
- Download the latest BIOS file from the Internet
- Update the BIOS from an updated BIOS file
- Update the BIOS directly from the Internet, and
- View the BIOS version information.

This utility is available in the support CD that comes with the motherboard package.



ASUS Update requires an Internet connection either through a network or an Internet Service Provider (ISP).

Installing ASUS Update

To install ASUS Update:

1. Place the support CD in the optical drive. The Drivers menu appears.
2. Click the Utilities tab, then click **Install ASUS Update VX.XX.XX**.
3. The ASUS Update utility is copied to your system.



Quit all Microsoft® Windows® applications before you update the BIOS using this utility.

Updating the BIOS through the Internet

To update the BIOS through the Internet:

1. Launch the ASUS Update utility from the Windows® desktop by clicking **Start > Programs > ASUS > ASUSUpdate > ASUSUpdate**. The ASUS Update main window appears.

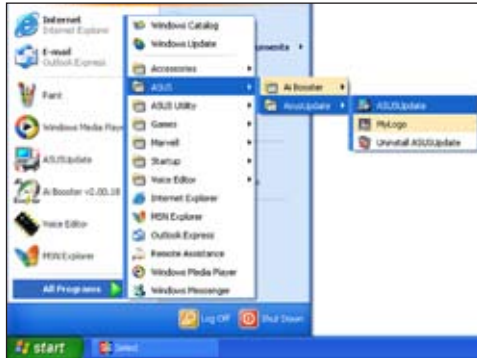

2. Select **Update BIOS** from the Internet option from the drop-down menu, then click **Next**.
3. Select the ASUS FTP site nearest you to avoid network traffic, or click Auto Select. Click **Next**.



- From the FTP site, select the BIOS version that you wish to download. Click **Next**.
- Follow the screen instructions to complete the update process.



The ASUS Update utility is capable of updating itself through the Internet. Always update the utility to avail all its features.



Updating the BIOS through a BIOS file

To update the BIOS through a BIOS file:

- Launch the ASUS Update utility from the Windows® desktop by clicking **Start > Programs > ASUS > ASUSUpdate > ASUSUpdate**. The ASUS Update main window appears.
- Select **Update BIOS** from a file option from the drop-down menu, then click **Next**.



- Locate the BIOS file from the **Open** window, then click **Save**.
- Follow the screen instructions to complete the update process.

5.2 BIOS setup program

This motherboard supports a programmable firmware chip that you can update using the provided utility described in section “5.1 Managing and updating your BIOS.”

Use the BIOS Setup program when you are installing a motherboard, reconfiguring your system, or prompted to “Run Setup”. This section explains how to configure your system using this utility.

Even if you are not prompted to use the Setup program, you can change the configuration of your computer in the future. For example, you can enable the security password feature or change the power management settings. This requires you to reconfigure your system using the BIOS Setup program so that the computer can recognize these changes and record them in the CMOS RAM of the firmware hub.

The firmware hub on the motherboard stores the Setup utility. When you start up the computer, the system provides you with the opportunity to run this program. Press during the Power-On-Self-Test (POST) to enter the Setup utility; otherwise, POST continues with its test routines.

If you wish to enter Setup after POST, restart the system by pressing <Ctrl+Alt+Delete>, or by pressing the reset button on the system chassis. You can also restart by turning the system off and then back on. Do this last option only if the first two failed.

The Setup program is designed to make it as easy to use as possible. Being a menu-driven program, it lets you scroll through the various sub-menus and make your selections from the available options using the navigation keys.



-
- The default BIOS settings for this motherboard apply for most conditions to ensure optimum performance. If the system becomes unstable after changing any BIOS settings, load the default settings to ensure system compatibility and stability. Select the **Load Setup Defaults** item under the Exit Menu. See section “5.8 Exit Menu.”
 - The BIOS setup screens shown in this section are for reference purposes only, and may not exactly match what you see on your screen.
 - Visit the ASUS website (www.asus.com) to download the latest BIOS file for this motherboard.
-

5.2.1 BIOS menu screen

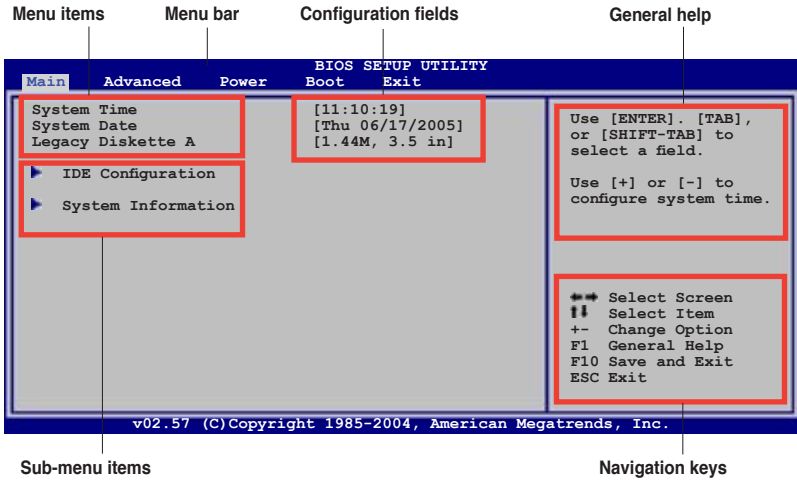

5.2.2 Menu bar

The menu bar on top of the screen has the following main items:

- Main For changing the basic system configuration
- Advanced For changing the advanced system settings
- Power For changing the advanced power management (APM) configuration
- Boot For changing the system boot configuration
- Exit For selecting the exit options and loading default settings

To select an item on the menu bar, press the right or left arrow key on the keyboard until the desired item is highlighted.

5.2.3 Navigation keys

At the bottom right corner of a menu screen are the navigation keys for that particular menu. Use the navigation keys to select items in the menu and change the settings.



Some of the navigation keys differ from one screen to another.

5.2.4 Menu items

The highlighted item on the menu bar displays the specific items for that menu. For example, selecting Main shows the Main menu items.

The other items (Advanced, Power, Boot, and Exit) on the menu bar have their respective menu items.

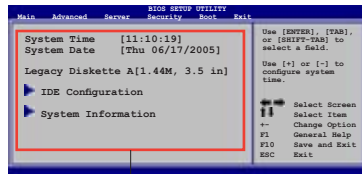

Main menu items

5.2.5 Sub-menu items

A solid triangle before each item on any menu screen means that the item has a sub-menu. To display the sub-menu, select the item and press <Enter>.

5.2.6 Configuration fields

These fields show the values for the menu items. If an item is user-configurable, you can change the value of the field opposite the item. You cannot select an item that is not user-configurable.

A configurable field is enclosed in brackets, and is highlighted when selected. To change the value of a field, select it then press <Enter> to display a list of options. Refer to “5.2.7 Pop-up window.”

5.2.7 Pop-up window

Select a menu item then press <Enter> to display a pop-up window with the configuration options for that item.

5.2.8 Scroll bar

A scroll bar appears on the right side of a menu screen when there are items that do not fit on the screen. Press the Up/Down arrow keys or <Page Up> /<Page Down> keys to display the other items on the screen.

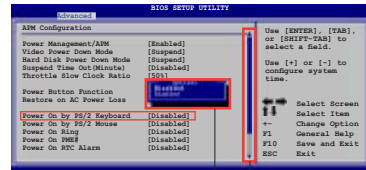

Pop-up window

Scroll bar

5.2.9 General help

At the top right corner of the menu screen is a brief description of the selected item.

5.3 Main menu

When you enter the BIOS Setup program, the **Main** menu screen appears, giving you an overview of the basic system information.



Refer to section "5.2.1 BIOS menu screen" for information on the menu screen items and how to navigate through them.

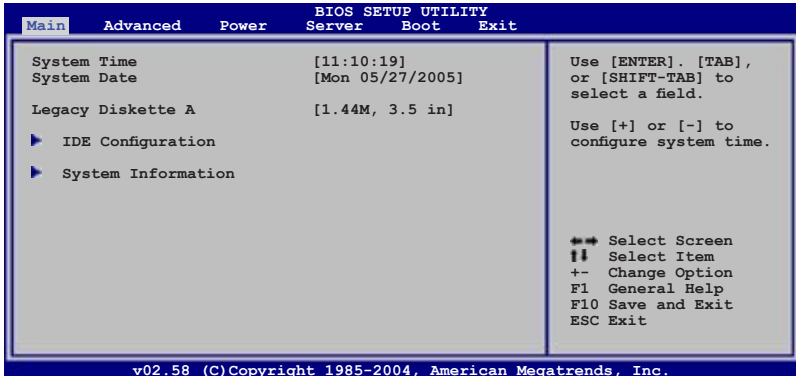

5.3.1 System Time [xx:xx:xx]

Allows you to set the system time.

5.3.2 System Date [Day xx/xx/xxxx]

Allows you to set the system date.

5.3.3 Legacy Diskette A [1.44M, 3.5 in.]

Sets the type of floppy drive installed. Configuration options: [Disabled]
[360K, 5.25 in.] [1.2M, 5.25 in.] [720K, 3.5 in.] [1.44M, 3.5 in.] [2.88M, 3.5 in.]

5.3.4 IDE Configuration

The items in this menu allow you to set or change the configurations for the IDE devices installed in the system. Select an item then press <Enter> if you wish to configure the item.

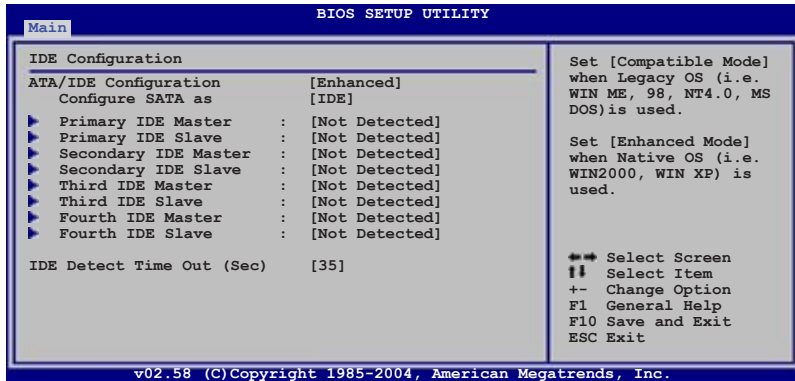

ATA/IDE Configuration [Enhanced]

Allows selection of the IDE operation mode depending on the installed operating system (OS). Set to [Enhanced] if you are using native OS, e.g. Windows® 2000/XP. Set to [Compatible] if you are using legacy OS, e.g. Windows ME/98/NT, MS-DOS. Configuration options: [Disabled] [Compatible] [Enhanced]



The items **Configure SATA as** and **Third, Fourth IDE Master/Slave** options appear only when you set the **ATA/IDE Configuration** to [Enhanced].

Configure SATA As [IDE]

Sets the configuration for the Serial ATA connectors supported by the Southbridge chip.

If you want to use the Serial ATA hard disk drives as Parallel ATA physical storage devices, set this item to [IDE].

Set this item to [RAID], if you want to create a RAID 0, RAID 1, RAID 0+1, or software RAID 5 configurations using the Intel® Matrix Storage Manager or if you want to create a RAID 0, RAID 1, RAID 0+1 configurations using the LSI Logic Embedded SATA RAID Setup Utility.

The AHCI allows the onboard storage driver to enable advanced Serial ATA features that enhance storage performance on random workloads by allowing the drive to internally optimize the order of commands.

If you want the Serial ATA hard disk drives to use the Advanced Host Controller Interface (AHCI), set this item to [AHCI]. For details on AHCI, go to:

www.intel.com/support/chipsets/imst/sb/CS-012304.htm

www.intel.com/support/chipsets/imst/sb/CS-012305.htm

The SATA controller is set to Native mode when this item is set to [RAID] or [AHCI].



The item **Legacy IDE Channels** appears only when you set the **ATA/IDE Configuration** to [Compatible].

Legacy IDE Channels [SATA Pri, PATA Sec]

Allows you to set Serial ATA, Parallel ATA, or both, to native mode.

Configuration options: [SATA Only] [PATA Pri, SATA Sec]

[SATA Pri, PATA Sec] [PATA Only]

IDE Detect Time Out (Sec) [35]

Selects the time our value (in seconds) for detecting ATA/ATAPI devices.

Configuration options: [0] [5] [10] [15] [20] [25] [30] [35]

5.3.5 Primary, Secondary, Third, Fourth IDE Master/Slave

The BIOS automatically detects the connected IDE devices. There is a separate sub-menu for each IDE device. Select a device item, then press <Enter> to display the IDE device information.

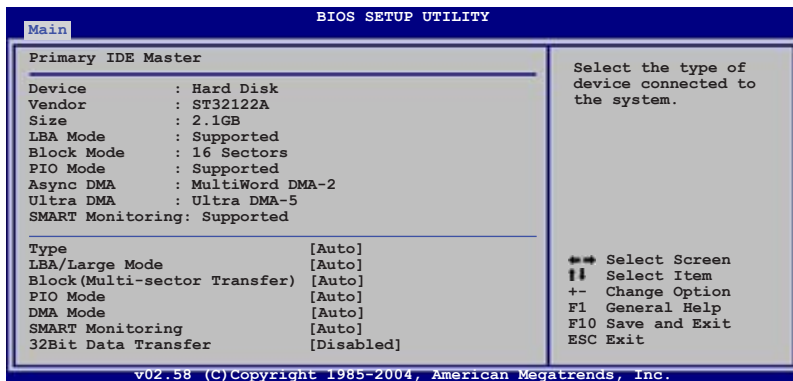

The BIOS automatically detects the values opposite the dimmed items (Device, Vendor, Size, LBA Mode, Block Mode, PIO Mode, Async DMA, Ultra DMA, and SMART monitoring). These values are not user-configurable. These items show N/A if no IDE device is installed in the system.

Type [Auto]

Selects the type of IDE drive. Setting to [Auto] allows automatic selection of the appropriate IDE device type. Select [CDROM] if you are specifically configuring a CD-ROM drive. Select [ARMD] (ATAPI Removable Media Device) if your device is either a ZIP, LS-120, or MO drive. Configuration options: [Not Installed] [Auto] [CDROM] [ARMD]

LBA/Large Mode [Auto]

Enables or disables the LBA mode. Setting to [Auto] enables the LBA mode if the device supports this mode, and if the device was not previously formatted with LBA mode disabled. Configuration options: [Disabled] [Auto]

Block (Multi-sector Transfer) [Auto]

Enables or disables data multi-sectors transfers. When set to [Auto], the data transfer from and to the device occurs multiple sectors at a time if the device supports multi-sector transfer feature. When set to [Disabled], the data transfer from and to the device occurs one sector at a time. Configuration options: [Disabled] [Auto]

PIO Mode [Auto]

Selects the PIO mode.
Configuration options: [Auto] [0] [1] [2] [3] [4]

DMA Mode [Auto]

Selects the DMA mode. Configuration options: [Auto] [SWDMA0] [SWDMA1] [SWDMA2] [MWDMA0] [MWDMA1] [MWDMA2] [UDMA0] [UDMA1] [UDMA2]

SMART Monitoring [Auto]

Sets the Smart Monitoring, Analysis, and Reporting Technology.
Configuration options: [Auto] [Disabled] [Enabled]

32Bit Data Transfer [Disabled]

Enables or disables 32-bit data transfer.
Configuration options: [Disabled] [Enabled]

5.3.6 System Information

This menu gives you an overview of the general system specifications. The BIOS automatically detects the items in this menu.

```
BIOS SETUP UTILITY
Main
AMIBIOS
Version      : 08.00.11
Build Date   : 12/01/05

Processor
Type         : Genuine Intel(R) CPU 3.20GHz
Speed        : 3200 MHz
Count        : 1

System Memory
Total        : 1024MB

*** Select Screen
!! Select Item
+- Change Option
F1 General Help
F10 Save and Exit
ESC Exit

v02.58 (C)Copyright 1985-2004, American Megatrends, Inc.
```

AMI BIOS

Displays the auto-detected BIOS information.

Processor

Displays the auto-detected CPU specification.

System Memory

Displays the auto-detected total system memory.

5.4 Advanced menu

The Advanced menu items allow you to change the settings for the CPU and other system devices.



Take caution when changing the settings of the Advanced menu items. Incorrect field values can cause the system to malfunction.

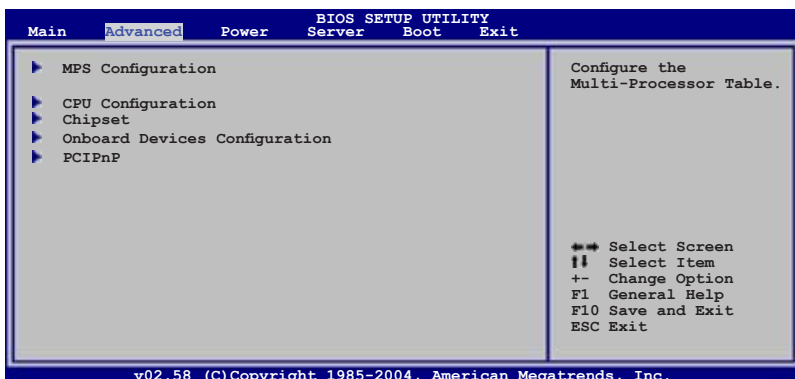

5.4.1 MPS Configuration

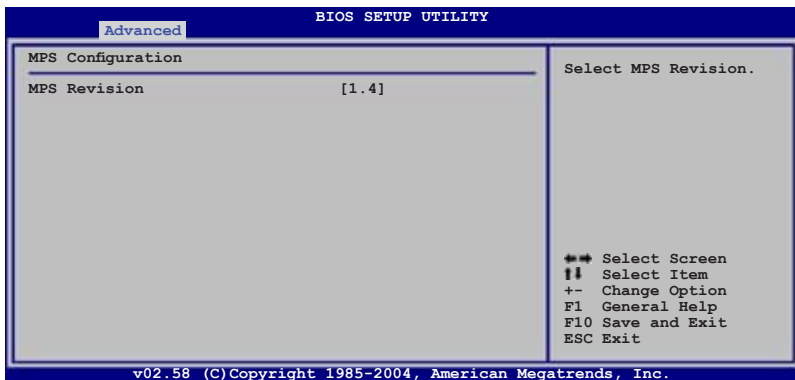

MPS Revision [1.4]

Allows you to select the multi-processor system version.

Configuration options: [1.1] [1.4]

5.4.2 CPU Configuration

The items in this menu show the CPU-related information that the BIOS automatically detects.

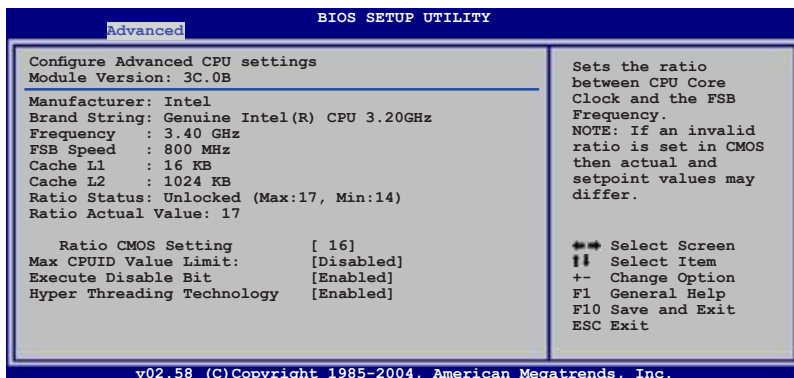

Ratio CMOS Setting [16]

Sets the ratio between the CPU Core Clock and the Front Side Bus frequency. The default value of this item is auto-detected by the BIOS. Use the <+> or <-> keys to adjust the values. Configuration options: [8]...[28]



You can only adjust the **Ratio CMOS Setting** if you installed an unlocked CPU. Refer to the CPU documentation for details.

Max CPUID Value Limit [Disabled]

Setting this item to [Enabled] allows legacy operating systems to boot even without support for CPUs with extended CPUID functions. Configuration options: [Disabled] [Enabled]

Execute Disable Bit [Enabled]

When this item is set to [Disabled], the BIOS forces the XD feature flag to always return to (0). Configuration options: [Disabled] [Enabled]



The Hyper-Threading Technology item appears only when you installed an Intel® Pentium® 4 CPU that supports the Hyper-Threading Technology. Hyper-Threading is not supported when you installed a dual-core CPU.

Hyper-Threading Technology [Enabled]

Allows you to enable or disable the processor Hyper-Threading Technology. Configuration options: [Disabled] [Enabled]



The following items appear only when you installed an Intel® Pentium® 4 dual-core CPU.

C1E Support [Disabled]

When set to [Enabled], BIOS automatically checks the CPU capability to enable C1E support. In C1E mode, the CPU has lower power consumption when idle. Configuration options: [Enabled] [Disabled]

Single Logical Processor Mode [Disabled]

Allows you to enable or disable the single logical processor mode for dual-core CPUs. Configuration options: [Disabled] [Enabled]

Intel(R) SpeedStep Technology [Automatic]

Allows you to use the Enhanced Intel SpeedStep® Technology. When set to [Automatic], you can adjust the system power settings in the operating system to use the EIST feature.

Set this item to [Disabled] if you do not want to use the EIST.

Configuration options: [Automatic] [Disabled]



The motherboard comes with a BIOS file that supports EIST.

5.4.3 Chipset Configuration

The Chipset Configuration menu allows you to change the advanced chipset settings. Select an item then press <Enter> to display the sub-menu.

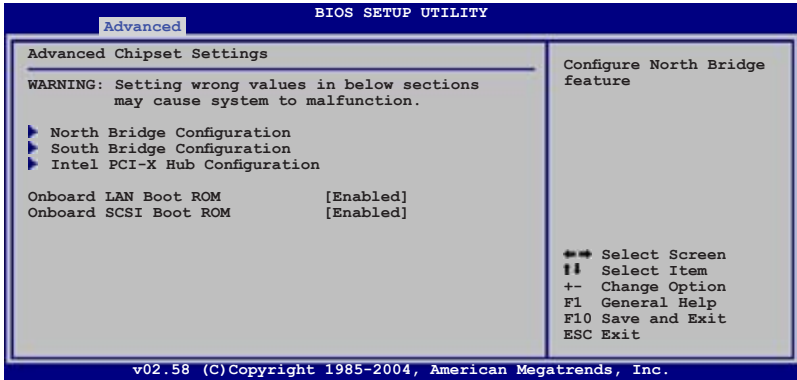

Onboard LAN Boot ROM [Enabled]

Allows you to enable or disable the option ROM in the onboard LAN controller.
Configuration options: [Disabled] [Enabled]

Onboard SCSI Boot ROM [Enabled]

Allows you to enable or disable the option ROM in the onboard SCSI controller.
Configuration options: [Disabled] [Enabled]

NorthBridge Configuration

The NorthBridge Configuration menu allows you to change the Northbridge related settings.

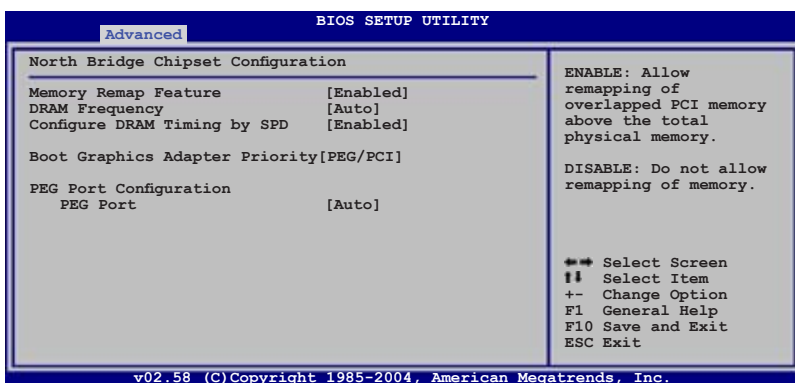

Memory Remap Feature [Enabled]

Allows you to remap the overlap PCI memory over the total physical memory.
Configuration options: [Disabled] [Enabled]

DRAM Frequency [Auto]

Allows you to set the DDR operating frequency.
Configuration options: [Auto] [533 MHz] [667 MHz]

Configure DRAM Timing by SPD [Enabled]

When this item is enabled, the DRAM timing parameters are set according to the DRAM SPD (Serial Presence Detect). When disabled, you can manually set the DRAM timing parameters through the DRAM sub-items. The following sub-items appear when this item is disabled. Configuration options: [Disabled] [Enabled]

DRAM CAS# Latency [5]

Controls the latency between the SDRAM read command and the time the data actually becomes available. Configuration options: [5] [4] [3]

DRAM RAS# to CAS# Delay [6 DRAM Clocks]

Controls the latency between the DDR SDRAM active command and the read/write command. Configuration options: [2 DRAM Clocks] [3 DRAM Clocks] [4 DRAM Clocks] [5 DRAM Clocks] [6 DRAM Clocks]

DRAM RAS# Precharge [6 DRAM Clocks]

Controls the idle clocks after issuing a precharge command to the DDR SDRAM. Configuration options: [2 DRAM Clocks] [3 DRAM Clocks] [4 DRAM Clocks] [5 DRAM Clocks] [6 DRAM Clocks]

DRAM RAS# Activate to Precharge Delay [15 DRAM Clocks]

Configuration options: [4 DRAM Clocks] [5 DRAM Clocks] ~ [15 DRAM Clocks]

Boot Graphic Adapter Priority [PEG/PCI]

Allows selection of the graphics controller to use as primary boot device.

Configuration options: [PEG/PCI] [PCI/PEG]

PEG Port Configuration

PEG Port [Auto]

Allows you to set or disable the PCI Express Graphic port.

Configuration options: [Auto] [Disabled]

SouthBridge Configuration

The SouthBridge Configuration menu allows you to change the Southbridge related settings.

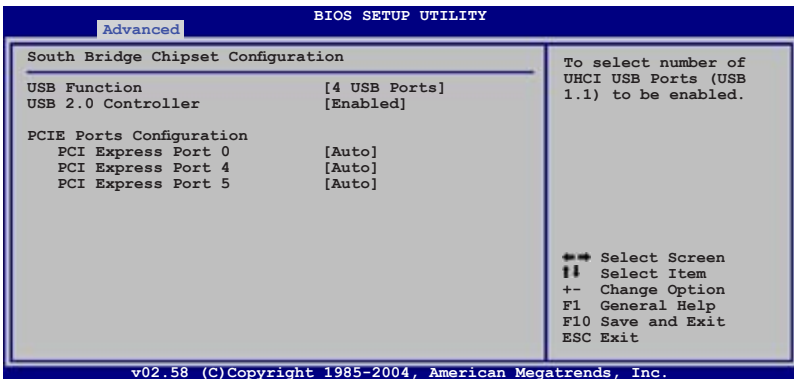

USB Function [4 USB Ports]

Allows you to enable a specific number of USB ports, or disable the USB function.

Configuration options: [Disabled] [2 USB Ports] [4 USB Ports]

USB 2.0 Controller [Enabled]

Allows you to enable or disable the USB 2.0 controller.

Configuration options: [Enabled] [Disabled]

PCI Express Port Configuration

PCI Express Port 0 [Auto]

Allows you to set or disable the PCI Express Port 0.
Configuration options: [Auto] [Disabled]

PCI Express Port 4 [Auto]

Allows you to set or disable the PCI Express Port 4.
Configuration options: [Auto] [Disabled]

PCI Express Port 5 [Auto]

Allows you to set or disable the PCI Express Port 5.
Configuration options: [Auto] [Disabled]

Intel PCI-X Hub Configuration

The Intel PCI-X Hub Configuration menu allows you to change the Intel PCI Express controller related settings.

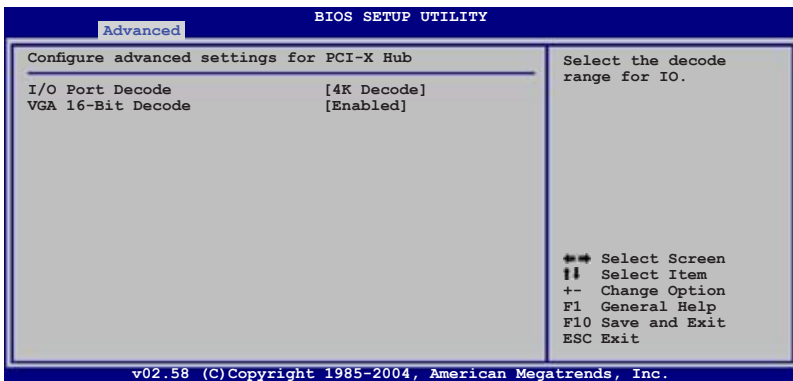

I/O Port Decode [4K Decode]

Allows you to set the decode range for the I/O controller.
Configuration options: [4K Decode] [1K Decode]

VGA 16-Bit Decode [Enabled]

Allows you to enable or disable the decode for the VGA controller.
Configuration options: [Disabled] [Enabled]

5.4.4 Onboard Devices Configuration

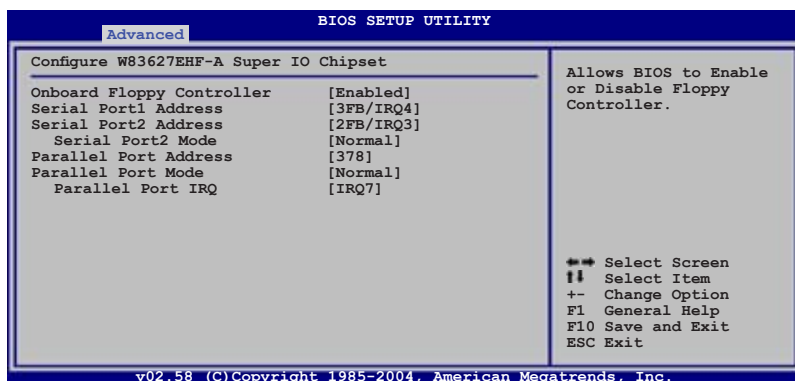

Onboard Floppy Controller [Enabled]

Allows you to enable the onboard floppy disk drive controller.

Configuration options: [Disabled] [Enabled]

Serial Port1 Address [3F8/IRQ4]

Allows you to select the Serial Port1 base address.

Configuration options: [Disabled] [3F8/IRQ4] [3E8/IRQ4] [2E8/IRQ3]

Serial Port2 Address [2F8/IRQ3]

Allows you to select the Serial Port2 base address.

Configuration options: [Disabled] [2F8/IRQ3] [3E8/IRQ4] [2E8/IRQ3]

Serial Port2 Mode [Normal]

Allows you to select the Serial Port2 mode.

Configuration options: [Normal] [IrDA] [ASK IR]

Parallel Port Address [378]

Allows you to select the Parallel Port base addresses.

Configuration options: [Disabled] [378] [278] [3BC]

Parallel Port Mode [Normal]

Allows you to select the Parallel Port mode.

Configuration options: [Normal] [Bi-directional] [ECP] [EPP] [ECP & EPP]

Parallel Port IRQ [IRQ7]

Configuration options: [IRQ5] [IRQ7]

5.4.5 PCI PnP

The PCI PnP menu items allow you to change the advanced settings for PCI/PnP devices. The menu includes setting IRQ and DMA channel resources for either PCI/PnP or legacy ISA devices, and setting the memory size block for legacy ISA devices.



Take caution when changing the settings of the PCI PnP menu items. Incorrect field values can cause the system to malfunction.

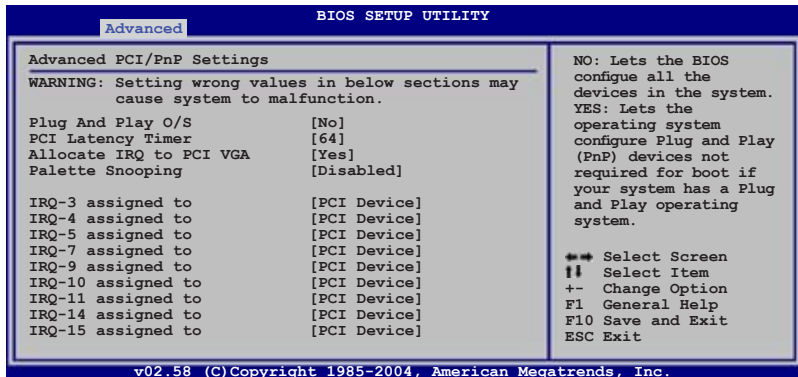

Plug And Play O/S [No]

When set to [No], BIOS configures all the devices in the system. When set to [Yes] and if you install a Plug and Play operating system, the operating system configures the Plug and Play devices not required for boot. Configuration options: [No] [Yes]

PCI Latency Timer [64]

Allows you to select the value in units of PCI clocks for the PCI device latency timer register. Configuration options: [32] [64] [96] [128] [160] [192] [224] [248]

Allocate IRQ to PCI VGA [Yes]

When set to [Yes], BIOS assigns an IRQ to PCI VGA card if the card requests for an IRQ. When set to [No], BIOS does not assign an IRQ to the PCI VGA card even if requested. Configuration options: [No] [Yes]

Palette Snooping [Disabled]

When set to [Enabled], the palette snooping feature informs the PCI devices that an ISA graphics device is installed in the system so that the latter can function correctly. Configuration options: [Disabled] [Enabled]

IRQ-xx assigned to [PCI Device]

When set to [PCI Device], the specific IRQ is free for use of PCI/PnP devices. When set to [Reserved], the IRQ is reserved for legacy ISA devices. Configuration options: [PCI Device] [Reserved]

5.5 Power Configuration

The Power Configuration menu items allow you to change the settings for the ACPI and Advanced Power Management (APM) features. Select an item then press <Enter> to display the configuration options.

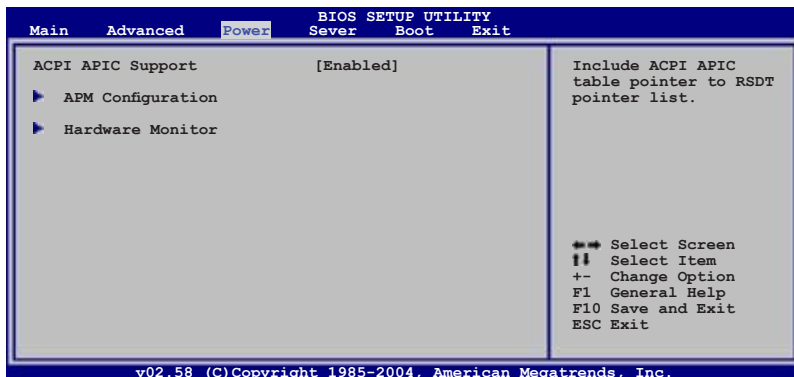

5.5.1 ACPI APIC Support [Enabled]

Allows you to enable or disable the Advanced Configuration and Power Interface (ACPI) support in the Advanced Programmable Interrupt Controller (APIC). When set to Enabled, the ACPI APIC table pointer is included in the RSDT pointer list. Configuration options: [Disabled] [Enabled]

5.5.2 APM Configuration

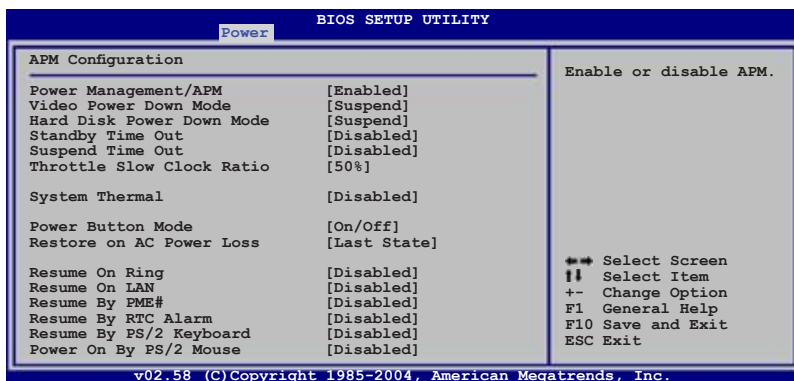

Power Management [Enabled]

Allows you to enable or disable the motherboard Advance Power Management (APM) feature. Configuration options: [Enabled] [Disabled]

Video Power Down Mode [Suspend]

Allows you to select the video power down mode

Configuration options: [Disabled] [Standby] [Suspend]

Hard Disk Power Down Mode [Suspend]

Allows you to select the hard disk power down mode

Configuration options: [Disabled] [Standby] [Suspend]

Standby Time Out [Disabled]

Allows you to select the specified time at which the system goes on standby mode.

Configuration options: [Disabled] [1 Min] [2 Min] [4 Min]

[8 Min] [10 Min] [20 Min] [30 Min] [40 Min] [50 Min] [60 Min]

Suspend Time Out [Disabled]

Allows you to select the specified time at which the system goes on suspend mode. Configuration options: [Disabled] [1 Min] [2 Min] [4 Min]

[8 Min] [10 Min] [20 Min] [30 Min] [40 Min] [50 Min] [60 Min]

Throttle Slow Clock Ratio [50%]

Allows you to select duty cycle in throttle mode.

Configuration options: [87.5%] [75.0%] [62.5%] [50.0%] [37.5%] [25.0%] [12.5%]

System Thermal [Disabled]

Allows you to enable or disable the system thermal control feature.

Configuration options: [Disabled] [Enabled]



The **Thermal Active Temperature** and **Thermal Slow Clock Ratio** items appear only when the **System Thermal** item is set to Enabled.

Thermal Active Temperature [60°C/140°F]

Allows you to specify the system thermal control activating temperature.

Configuration options: [40°C/104°F] [45°C/113°F] [50°C/122°F] [55°C/131°F]

[60°C/140°F] [65°C/149°F] [70°C/158°F] [75°C/167°F]

Thermal Slow Clock Ratio [50%]

Allows you to select the duty cycle in the throttle when a thermal override condition occurs. Configuration options: [87.5%] [75.0%] [62.5%] [50%] [37.5%] [25%]

[12.5%]

Power Button Function [On/Off]

Allows the system to go into On/Off mode or suspend mode when the power button is pressed. Configuration options: [On/Off] [Suspend]

Restore on AC Power Loss [Last State]

When set to Power Off, the system goes into off state after an AC power loss. When set to Power On, the system goes on after an AC power loss. When set to Last State, the system goes into either off or on state, whatever the system state was before the AC power loss.

Configuration options: [Power Off] [Power On] [Last State]

Resume On Ring [Disabled]

When set to [Enabled], the system enables the RI to generate a wake event while the computer is in Soft-off mode. Configuration options: [Disabled] [Enabled]

Resume On LAN [Disabled]

When set to [Enabled], the system enables the LAN to generate a wake event while the computer is in Soft-off mode. Configuration options: [Disabled] [Enabled]

Resume By PME# [Disabled]

When set to [Enabled], the system enables the PME to generate a wake event while the computer is in Soft-off mode.

Configuration options: [Disabled] [Enabled]

Resume By RTC Alarm [Disabled]

Allows you to enable or disable RTC to generate a wake event. When this item is set to [Enabled], the items RTC Alarm Date, RTC Alarm Hour, RTC Alarm Minute, and RTC Alarm Second appear with set values.

Configuration options: [Disabled] [Enabled]



The following items appear only when the **Power On RTC Alarm** item is set to Enabled.

RTC Alarm Date [Days] [15]

To set the alarm date, highlight this item and press the <+> or <-> key to make the selection. Configuration options: [Everyday] [1] [2] [3]...[31]

System Time [12:30:30]

To set the alarm time, highlight this item and press the <+> or <-> key to make the selection.

Resume By PS/2 Keyboard [Disabled]

Allows you to use specific keys on the keyboard to turn on the system. This feature requires an ATX power supply that provides at least 1A on the +5VSB lead. Configuration options: [Disabled] [Enabled]

Power On By PS/2 Mouse [Disabled]

When set to [Enabled], this parameter allows you to use the PS/2 mouse to turn on the system. This feature requires an ATX power supply that provides at least 1A on the +5VSB lead. Configuration options: [Disabled] [Enabled]

5.5.3 Hardware Monitor

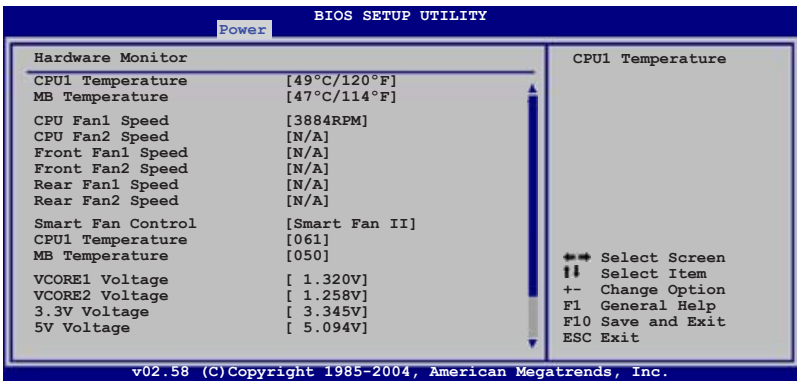

Use the down arrow key to display additional items.

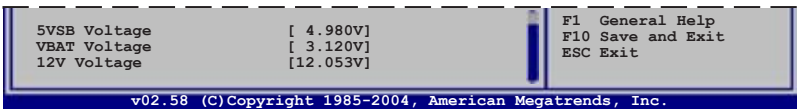

CPU1 Temperature [xxx°C/xxx°F]

MB Temperature [xxx°C/xxx°F]

The onboard hardware monitor automatically detects and displays the motherboard and CPU temperatures. Select [Disabled] if you do not wish to display the detected temperatures.

CPU Fan1/2 Speed [xxxxRPM] or [N/A]
Front Fan1/2 Speed [xxxxRPM] or [N/A]
Rear Fan1/2 Speed [xxxxRPM] or [N/A]

The onboard hardware monitor automatically detects and displays the CPU, front, and rear fan speed in rotations per minute (RPM). If the fan is not connected to the motherboard, the field shows N/A.

Smart Fan Control [Smart Fan II]

Allows you to enable or disable the ASUS Smart Fan feature that smartly adjusts the fan speeds for more efficient system operation. Configuration options:
[Disabled] [Smart Fan] [Smart Fan II]



The **CPU1 Temperature** and **MB Temperature** items appear when you set the **Smart Fan Control** item to [Smart Fan] or [Smart Fan II].

CPU1 Temperature [XXX]
MB Temperature [XXX]

Displays the detected CPU and system threshold temperature when the Smart Fan Control is enabled.

VCORE1 Voltage, VCORE2 Voltage, 3.3V Voltage, 5V Voltage, 5VSB Voltage, VBAT Voltage, 12V Voltage

The onboard hardware monitor automatically detects the voltage outputs through the onboard voltage regulators.

5.6 Server menu

The Server menu items allow you to customize the server features.

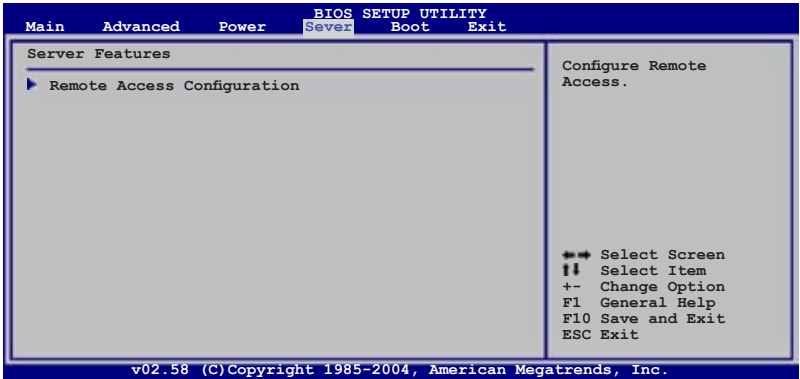

Remote Access Configuration

The items in this menu allow you to configure the Remote Access features. Select an item then press <Enter> to display the configuration options.

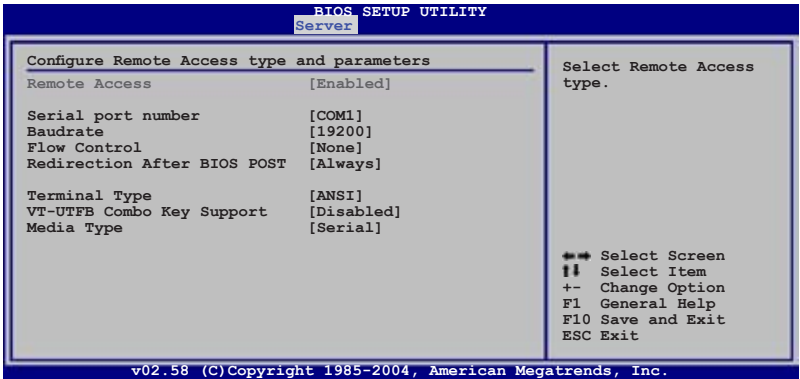

Remote Access [Enabled]

Enables or disables the remote access feature.

Configuration options: [Disabled] [Enabled]



The following items appear only when the **Remote Access** item is set to [Enabled].

Serial port number [COM1]

Allows you to select serial port for console redirection.

Configuration options: [COM1] [COM2]

Baudrate [19200]

Sets the Serial port settings.

Configuration options: [115200] [57600] [38400] [19200] [9600]

Flow Control [None]

Allows you to select the flow control for console redirection.

Configuration options: [None] [Hardware] [Software]

Redirection After BIOS POST [Always]

Sets the redirection mode after the BIOS Power-On Self-Test (POST). Some operating systems may not work when this item is set to Always.

Configuration options: [Disabled] [Boot Loader] [Always]

Terminal Type [ANSI]

Allows you to select the target terminal type.

Configuration options: [ANSI] [VT100] [VT-UTF8]

VT-UTF8 Combo Key Support [Disabled]

Enables or disables the VT-UTF8 combo key support for ANSI or VT100 terminals.

Configuration options: [Disabled] [Enabled]

Media Type [Serial]

Selects the media for console redirection. Configuration options: [Serial]

[LAN] [Serial + LAN]

5.7 Boot menu

The Boot menu items allow you to change the system boot options. Select an item then press <Enter> to display the sub-menu.

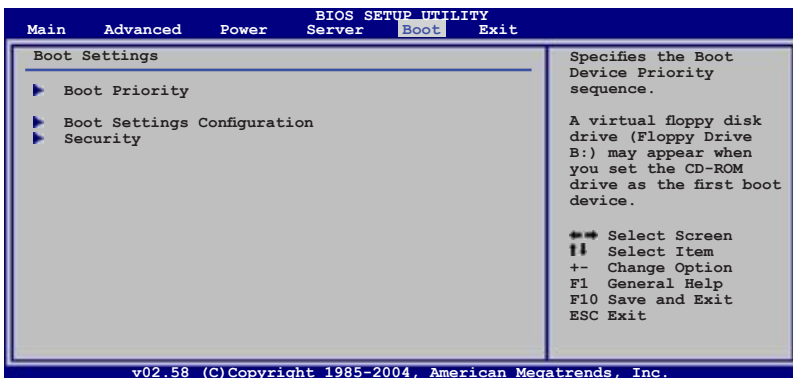

5.7.1 Boot Device Priority

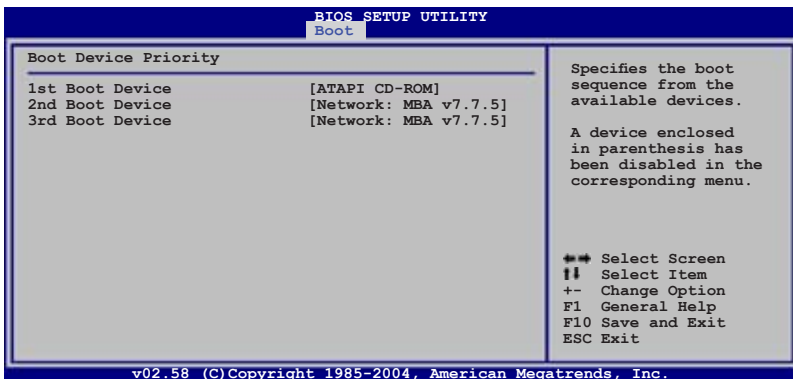

1st Boot Device [ATAPI CD-ROM]

2nd Boot Device [Network: MBA v7.7.5]

3rd Boot Device [Network: MBA v7.7.5]

These items specify the boot device priority sequence from the available devices. Configuration options: [1st FLOPPY Drive] [Network: MBA v7.7.5 Slot 0400] [Network: MBA v7.7.5 Slot 0300] [Disabled]

5.7.2 Boot Settings Configuration

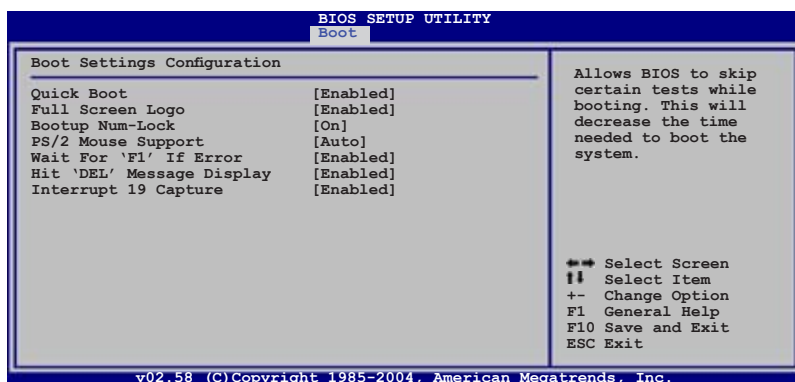

Quick Boot [Enabled]

Enabling this item allows the BIOS to skip some power on self tests (POST) while booting to decrease the time needed to boot the system. When set to [Disabled], BIOS performs all the POST items.

Configuration options: [Disabled] [Enabled]

Full Screen Logo [Enabled]

Allows you to enable or disable the full screen logo display feature. Configuration options: [Disabled] [Enabled]



Set this item to [Enabled] to use the ASUS MyLogo2™ feature.

Bootup Num-Lock [On]

Allows you to select the power-on state for the NumLock.

Configuration options: [Off] [On]

PS/2 Mouse Support [Auto]

Allows you to enable or disable support for PS/2 mouse.

Configuration options: [Disabled] [Enabled] [Auto]

Wait for 'F1' If Error [Enabled]

When set to Enabled, the system waits for the F1 key to be pressed when error occurs. Configuration options: [Disabled] [Enabled]

Hit 'DEL' Message Display [Enabled]

When set to Enabled, the system displays the message "Press DEL to run Setup" during POST. Configuration options: [Disabled] [Enabled]

Interrupt 19 Capture [Enabled]

When set to [Enabled], this function allows the option ROMs to trap Interrupt 19.

Configuration options: [Disabled] [Enabled]

5.7.3 Security

The Security menu items allow you to change the system security settings. Select an item then press <Enter> to display the configuration options.

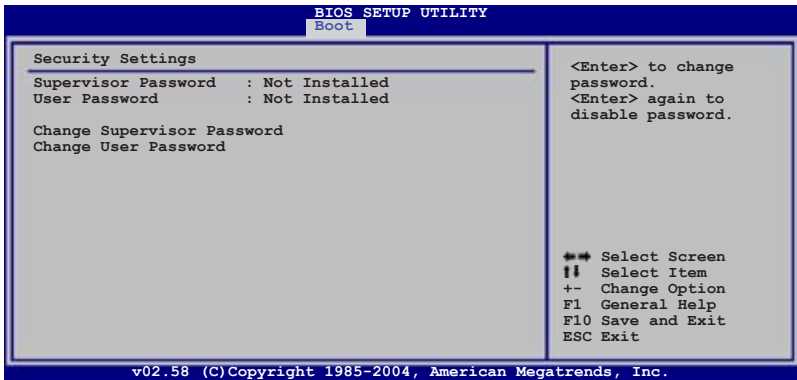

Change Supervisor Password

Select this item to set or change the supervisor password. The Supervisor Password item on top of the screen shows the default **Not Installed**. After you set a password, this item shows **Installed**.

To set a Supervisor Password:

1. Select the **Change Supervisor Password** item, then press <Enter>.
2. From the password box, type a password composed of at least six letters and/or numbers, then press <Enter>.
3. Confirm the password when prompted.

The message "Password Installed" appears after you successfully set your password.

To change the supervisor password, follow the same steps as in setting a user password.

To clear the supervisor password, select the **Change Supervisor Password** then press <Enter>. The message "Password Uninstalled" appears.



If you forget your BIOS password, you can clear it by erasing the CMOS Real Time Clock (RTC) RAM. See section "4.2 Jumpers" for information on how to erase the RTC RAM.

After you have set a supervisor password, the other items appear to allow you to change other security settings.

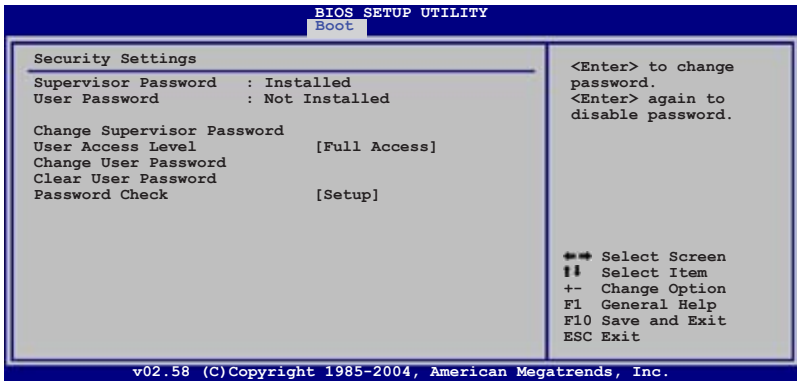

User Access Level [Full Access]

This item allows you to select the access restriction to the Setup items. Configuration options: [No Access] [View Only] [Limited] [Full Access]

No Access prevents user access to the Setup utility.

View Only allows access but does not allow change to any field.

Limited allows changes only to selected fields, such as Date and Time.

Full Access allows viewing and changing all the fields in the Setup utility.

Change User Password

Select this item to set or change the user password. The User Password item on top of the screen shows the default **Not Installed**. After you set a password, this item shows **Installed**.

To set a User Password:

1. Select the **Change User Password** item and press <Enter>.
2. On the password box that appears, type a password composed of at least six letters and/or numbers, then press <Enter>.
3. Confirm the password when prompted.

The message “Password Installed” appears after you set your password successfully.

To change the user password, follow the same steps as in setting a user password.

Clear User Password

Select this item to clear the user password.

Password Check [Setup]

When set to [Setup], BIOS checks for user password when accessing the Setup utility. When set to [Always], BIOS checks for user password both when accessing Setup and booting the system.

Configuration options: [Setup] [Always]

5.8 Exit menu

The Exit menu items allow you to load the optimal or failsafe default values for the BIOS items, and save or discard your changes to the BIOS items.

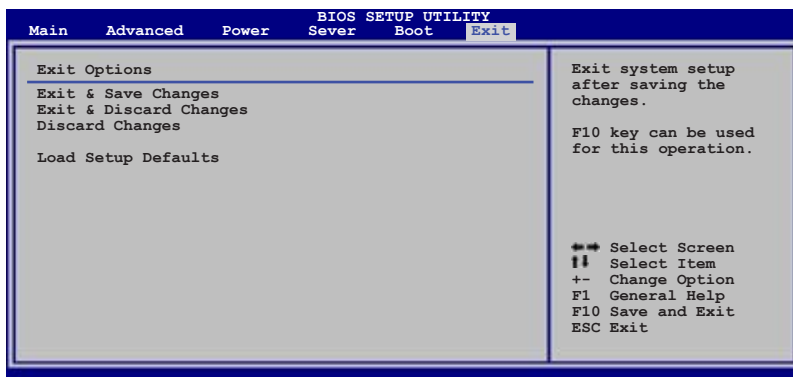

If you made changes to any of the settings in the menus, pressing <Esc> does not immediately exit this menu. A confirmation window appears and prompts you to either save your changes or cancel the command. Select one of the options from this menu to exit.

Exit & Save Changes

Select this option then press <Enter>, or simply press <F10>, to save your changes to CMOS before exiting the Setup utility.

When a confirmation window appears, select [OK] then press <Enter> to save your changes and exit Setup. If you wish to cancel the command, select [Cancel] then press <Enter> to return to the Exit menu.

Exit & Discard Changes

Select this option then press <Enter> to exit the Setup utility without saving your changes.

When a confirmation window appears, select [OK] then press <Enter> to discard your changes and exit Setup. If you wish to cancel the command, select [Cancel] then press <Enter> to return to the Exit menu.

Discard Changes

Select this option then press <Enter> to discard the changes that you made, and restore the previously saved settings.

When a confirmation window appears, select [OK] then press <Enter> to discard the changes, and load the previously saved settings. If you wish to cancel the command, select [Cancel] then press <Enter> to return to the Exit menu.

Load Setup Defaults

Select this option then press <Enter> to load the optimized settings for each of the Setup menu items.

When a confirmation window appears, select [OK] then press <Enter> to load the default settings. If you wish to cancel the command, select [Cancel] then press <Enter> to return to the Exit menu.

Chapter 6

This chapter provides information on how to configure your hard disk drives as RAID sets.



6.1 Setting up RAID

The motherboard comes with the following RAID solutions:

P5MT model

- **LSI Logic Embedded SATA RAID** technology embedded in the Intel® ICH7R Southbridge supports up to two SATA hard disk drives and RAID 0, RAID 1, and RAID 10 configurations.

P5MT-S model

- **Adaptec AIC-7901 PCI-X SCSI controller** supports SCSI hard disk drives and RAID 0, RAID 1, and RAID 0+1 configurations.

6.1.1 RAID definitions

RAID 0 (*Data striping*) optimizes two identical hard disk drives to read and write data in parallel, interleaved stacks. Two hard disks perform the same work as a single drive but at a sustained data transfer rate, double that of a single disk alone, thus improving data access and storage. Use of two new identical hard disk drives is required for this setup.

RAID 1 (*Data mirroring*) copies and maintains an identical image of data from one drive to a second drive. If one drive fails, the disk array management software directs all applications to the surviving drive as it contains a complete copy of the data in the other drive. This RAID configuration provides data protection and increases fault tolerance to the entire system. Use two new drives or use an existing drive and a new drive for this setup. The new drive must be of the same size or larger than the existing drive.

RAID 0+1 is *data striping and data mirroring* combined without parity (redundancy data) having to be calculated and written. With the RAID 0+1 configuration you get all the benefits of both RAID 0 and RAID 1 configurations. Use four new hard disk drives or use an existing drive and three new drives for this setup.

JBOD (*Spanning*) stands for **Just a Bunch of Disks** and refers to hard disk drives that are not yet configured as a RAID set. This configuration stores the same data redundantly on multiple disks that appear as a single disk on the operating system. Spanning does not deliver any advantage over using separate disks independently and does not provide fault tolerance or other RAID performance benefits.



If you want to boot the system from a hard disk drive included in a created RAID set, copy first the RAID driver from the support CD to a floppy disk before you install an operating system to the selected hard disk drive. Refer to Chapter 6 for details.

6.1.2 Installing hard disk drives

The motherboard supports Serial ATA (both models) and SCSI hard disk drives (P5MT-S model only) for RAID set configuration. For optimal performance, install identical drives of the same model and capacity when creating a disk array.

To install the SATA hard disks for RAID configuration:

1. Install the SATA hard disks into the drive bays following the instructions in the system user guide.
2. Connect a SATA signal cable to the signal connector at the back of each drive and to the SATA connector on the motherboard.
3. Connect a SATA power cable to the power connector on each drive.

To install the SCSI hard disks for RAID configuration:

1. Install the SCSI hard disks into the drive bays following the instructions in the system user guide.
2. Connect the SCSI interface cable connectors at the back of the SCSI drives.
3. Connect the other end of the SCSI interface cable to the SCSI connector on the motherboard.

6.1.3 Setting the RAID item in BIOS

You must set the RAID item in the BIOS Setup before you can create a RAID set from SATA hard disk drives attached to the SATA connectors supported by the Intel® ICH7R Southbridge chip. To do this:

1. Enter the BIOS Setup during POST.
2. Go to the **Main Menu**, select **IDE Configuration**, then press <Enter>.
3. Set the **ATA/IDE Configuration** item to [Enhanced Mode], then press <Enter>.
4. Set the Configure **SATA As** item to [RAID].
5. Save your changes, then exit the BIOS Setup.



Refer to Chapter 5 for details on entering and navigating through the BIOS Setup.

6.1.4 RAID configuration utilities

Depending on the RAID connectors that you use, you can create a RAID set using the utilities embedded in each RAID controller. For example, for **P5MT model**, use the LSI Logic Embedded SATA RAID Setup Utility if you installed SATA hard disk drives on the SATA connectors supported by the Intel® ICH7R Southbridge.

For **P5MT-S** model, use the Adaptec SCSISelect™ Utility if you installed SCSI hard disk drives to the SCSI connector(s) supported by the Adaptec AIC-7901 PCI-X SCSI controller. Refer to the succeeding sections for details on how to use each RAID configuration utility.

6.2 LSI Logic Embedded SATA RAID Setup Utility

The LSI Logic Embedded SATA RAID Setup Utility allows you to create RAID 0, RAID 1, or RAID 10 set(s) from SATA hard disk drives connected to the SATA connectors supported by the motherboard ICH7R Southbridge chip.

To enter the LSI Logic Embedded SATA RAID Setup Utility:

1. Turn on the system after installing all the SATA hard disk drives.
2. During POST, the LSI Logic Embedded SATA RAID Setup Utility automatically detects the installed SATA hard disk drives and displays any existing RAID set(s). Press <Ctrl> + <M> to enter the utility.

```
LSI Logic Embedded SATA RAID BIOS Version 5.4.05091647R
(c)2004 Copyright LSI Logic Corporation. All Rights Reserved.

LSI Logic Embedded SATA RAID Found at PCI Bus No. 00 Dev No. 1F
Scanning for Part 0 ... Responding: HD57225124L S000 117800MB UDMA 5
Scanning for Part 1 ... Responding: HD57225124L S000 117800MB UDMA 5

01 Logical drive(s) Configured.
Array# Mode Stripe Size No.Of Stripes DriveSize Status
00 Reliability 64KB(128 Sectors) 02 114376MB Online

Press Ctrl-M to run LSI Logic Embedded SATA RAID Setup Utility.
```



The LSI Logic Embedded SATA RAID auto configures to RAID 1 when the SATA to RAID Mode is enabled.

3. The utility main window appears. Use the arrow keys to select an option from the Management Menu, then press <Enter>. Refer to the Management Menu descriptions on the next page.

At the bottom of the screen is the legend box. The keys on the legend box allow you to navigate through the setup menu options or execute commands. The keys on the legend box vary according to the menu level.

```
-----
-- Management Menu --
-- Configure
-- Initialize
-- Objects
-- Rebuild
-- Check Consistency
-----

-----
-- Configure Logical Drives)
-----

Use Cursor Keys To Navigate Between Items And Press Enter To Select An Option
```

Menu	Description
Configure	Allows you to create RAID 0 or RAID 1 set using the Easy Configuration or the New Configuration command. This menu also allows you to view, add, or clear RAID configurations or select the boot drive
Initialize	Allows you to initialize the logical drives of a created RAID set
Objects	Allows you to initialize logical drives or change the logical drive parameters
Rebuild	Allows you to rebuild failed drives
Check Consistency	Allows you to check the data consistency of the logical drives of a created RAID set

6.2.1 Creating a RAID 0 or RAID 1 set

The LSI Logic Embedded SATA RAID Setup Utility allows you to create a RAID 0 or RAID 1 set using two types of configurations: Easy and New.

In **Easy Configuration**, the logical drive parameters are set automatically including the size and stripe size (RAID 1 only).

In **New Configuration**, you manually set the logical drive parameters and assign the set size and stripe size (RAID 1 only).

Using Easy Configuration

To create a RAID set using the **Easy Configuration** option:

1. From the utility main menu, highlight **Configure**, then press <Enter>.
2. Use the arrow keys to select **Easy Configuration**, then press <Enter>.

```

-- Configuration Menu --
Easy Configuration
Management New Configuration
Configure View/Add Configuration
Initialize Clear Configuration
Objects Select Boot Drive
Rebuild
Check Consistency

```

Defines Physical Arrays. An Arrow Will Automatically Become A Logical Drive
Use Cursor Keys To Navigate Between Items And Press Enter To Select An Option

3. The **ARRAY SELECTION MENU** displays the available drives connected to the SATA ports. Select the drives you want to include in the RAID set, then press <SpaceBar>. When selected, the drive indicator changes from **READY** to **ONLIN A[X]-[Y]**, where X is the array number, and Y is the drive number.

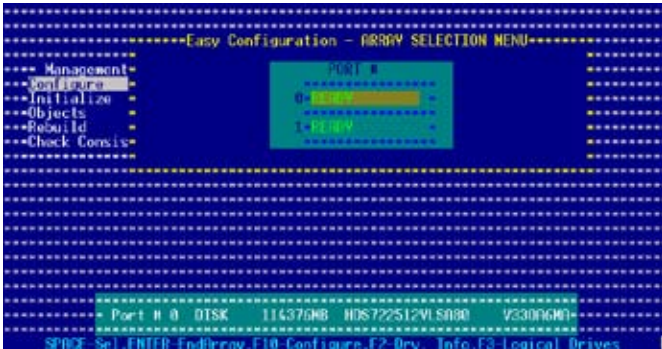

The information of the selected hard disk drive displays at the bottom of the screen.

4. Select all the drives required for the RAID set, then press <Enter>. The configurable array appears on screen.

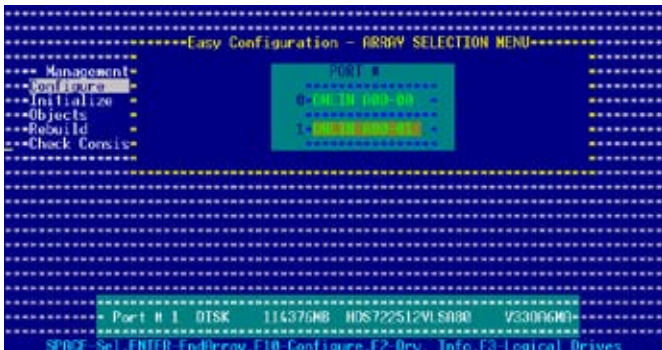

5. Press <F10>, select the configurable array, then press <SpaceBar>.

```
----- Easy Configuration - ARRAY SELECTION MENU -----
----- Select Configurable Array(s) -----
Management
Configure
Initialize
Objects
Rebuild
Check Consis
-----
Cursor Keys: SPACE (to) Select F2-ChildInfo F3-Set:Info F10-Configure ESC-Quit
```

The logical drive information appears including a Logical Drive menu that allows you to change the logical drive parameters.

```
----- Logical Drive(s) Configured -----
LD RAID Size #Stripes StripeSz Status
-----
0 1 114376MB 2 64 KB ONLINE
Management
Configure
Initialize
Objects
Rebuild
Check Cons
-----
----- Logical Drive 0 -----
RAID =
Size = 114376MB
Stripe Size
Recall
SPIN = NO
-----
Choose RAID Level for This Logical Drive
Use Cursor Keys To Navigate Between Rows And Press Enter To Select An Option
```

6. Select **RAID** from the **Logical Drive** menu, then press <Enter>.
7. Select the RAID level from the menu, then press <Enter>.



You need at least two identical hard disk drives when creating a RAID 1 set.

```

***** Logical Drive(s) Configured *****
***** LD  RAID  Size  #Stripes  StripeSz  Status *****
***** 0    1    114376MB  2        64 KB    ONLINE *****
***** Manage *****
***** Configure *****
***** Initialize *****
***** Objects *****
***** Rebuild *****
***** Check Cons *****

***** Logical Drive 0 ***** RAID Level *****
***** RAID = 1 ***** RAID 0 *****
***** Size = 114376MB ***** RAID 1 *****
***** Stripe Size *****
***** Accept *****
***** SPIN = ND *****

***** Choose RAID level for this logical drive *****

Use Cursor Keys To Navigate Between Items And Press Enter To Select An Option

```

8. When creating a RAID 1 set, select **Stripe Size** from the **Logical Drive** menu, then press <Enter>.
- When creating a RAID 0 set, proceed to step 10.
9. Key-in the stripe size, then press <Enter>.

```

***** Logical Drive(s) Configured *****
***** LD  RAID  Size  #Stripes  StripeSz  Status *****
***** 0    1    114376MB  2        64 KB    ONLINE *****
***** Manage *****
***** Configure *****
***** Initialize *****
***** Objects *****
***** Rebuild *****
***** Check C *****
***** Enter Stripe Size In KB (4, 8, 16, 32, 64, 128)? 64 *****

***** Logical Drive 0 *****
***** RAID = 1 *****
***** Size = 114376MB *****
***** Stripe Size *****
***** Accept *****
***** SPIN = ND *****

***** Enter Stripe Size In KB (4, 8, 16, 32, 64, 128)? *****

Use Cursor Keys To Navigate Between Items And Press Enter To Select An Option

```



For server systems, we recommend that you use a lower array block size. For multimedia computer systems used mainly for audio and video editing, we recommend a higher array block size for optimum performance.

- When finished setting the selected logical drive configuration, select Accept from the menu, then press <Enter>.

```

***** Logical Drive(s) Configured *****
----- LD      RRID      Size      #Stripes  StripeSz  Status -----
*****
Management= 0          1          114375MB  2          64 KB     ONLINE
Configuration=
Initialize=
Objects = LD
Rebuild =
Check Con=

----- Logical Drive 0 -----
RRID = 1
Size = 114375MB
Stripe Size =
Stripes =
SPBM = NO

-----
Accept This Logical Drive Configuration And Go To Next Logical Drive
-----
Use Cursor Keys To Navigate Between Items And Press Enter To Select An Option

```

- When finished setting the selected logical drive configuration, select Accept from the menu, then press <Enter>.
- Follow steps 5 to 10 to configure additional logical drives.
- When prompted, save the configuration, then press <Esc> to return to the Management Menu.

```

----- Configuration Menu ----- Save Configuration ?
----- Save Configuration ----- Yes
----- No -----
Management= New Configuration
Configuration= View/Add Configuration
***** Logical Drive(s) Configured *****
Objects = LD      RRID      Size      #Stripes  StripeSz  Status
Rebuild = 0          1          114375MB  2          64 KB     ONLINE
Check Con=

-----
Select VFS Dr NO
-----
Use Cursor Keys To Navigate Between Items And Press Enter To Select An Option

```

- Select all the drives required for the RAID 10 set, then press <Enter>. The configurable array appears on screen.

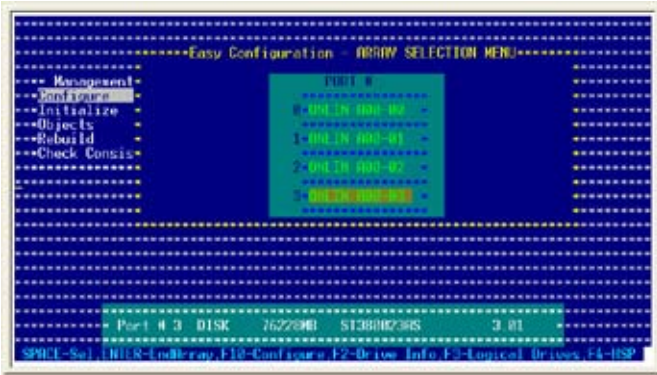

- Press <F10>, select the configurable array, then press <SpaceBar>.

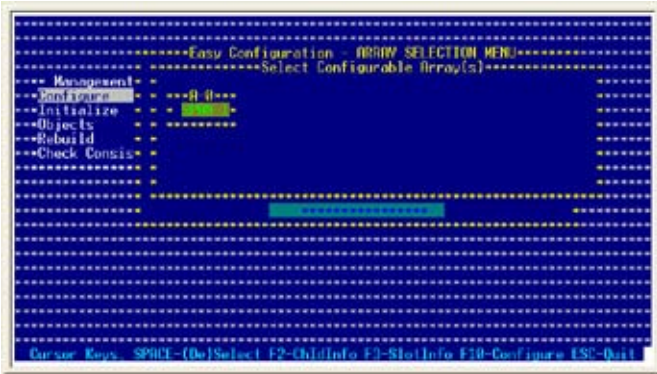

The logical drive information appears including a Logical Drive menu that allows you to change the logical drive parameters.

6. Select **RAID** from the Logical Drive menu, then press <Enter>.
7. Select **RAID 10** from the menu, then press <Enter>.



You need at least four identical hard disk drives when creating a RAID 10 set.

```

..... Logical Drive(s) Configured .....
----- LD RAID Size #Stripes StripeSz Status -----
----- 0 0 304912MB 4 64 KB ONLINE -----
-- Message --
-- Initialize --
-- Objects --
-- Rebuild --
-- Check Cons --
-----
-- Logical Drive 0 --
-- RAID = 0 -- RAID Level --
-- Size = 304912MB -- RAID 10 --
-- Stripe Size --
-- Accept --
-- SPIN = NO --
-----
-- Choose RAID Level for this Logical Drive --
-- Use Cursor Keys to Navigate Between Items and Press Enter to Select an Option --

```

8. Select **Stripe Size** from the Logical Drive menu, then press <Enter>.
9. Key-in the stripe size, then press <Enter>.

```

..... Logical Drive(s) Configured .....
----- LD RAID Size #Stripes StripeSz Status -----
----- 0 0 304912MB 4 64 KB ONLINE -----
-- Message --
-- Initialize --
-- Objects --
-- Rebuild --
-- Check Cons --
-----
-- Logical Drive 0 --
-- RAID = 10 --
-- Size = 152456MB --
-- Stripe Size --
-- Accept --
-- SPIN = YES --
-----
-- Enter Stripe Size In KB (8,16,32,64,128)? :64 --
-----
-- Enter Stripe Size In KB (8,16,32,64,128)? --
-- Use Cursor Keys to Navigate Between Items and Press Enter to Select an Option --

```



For server systems, we recommend that you use a lower array block size. For multimedia computer systems used mainly for audio and video editing, we recommend a higher array block size for optimum performance.

10. When finished setting the selected logical drive configuration, select **Accept** from the menu, then press <Enter>.

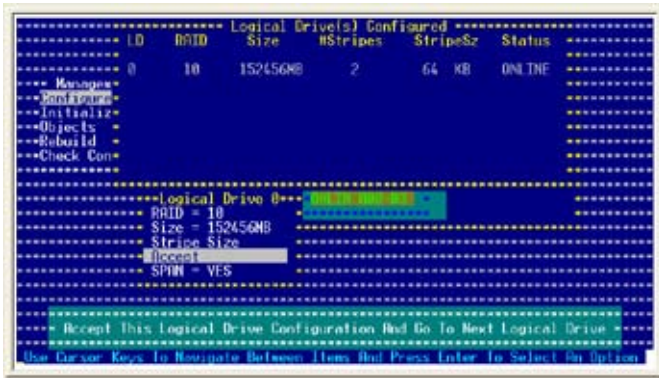

11. When prompted, save the configuration, then press <Esc> to return to the Management Menu.

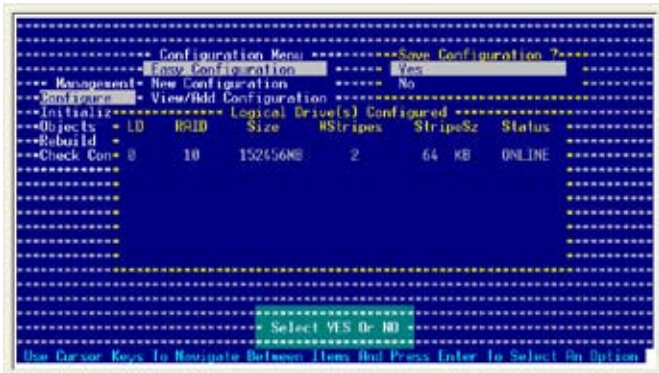

6.2.3 Adding or viewing a RAID configuration

You can add a new RAID configuration or view an existing configuration using the **View/Add Configuration** command.

Adding a new RAID configuration

To add a new RAID configuration:

1. From the Management Menu, highlight **Configure**, then press <Enter>.
2. Use the arrow keys to select **View/Add Configuration**, then press <Enter>.



3. The **ARRAY SELECTION MENU** displays the available drives connected to the SATA ports. Select the drive(s) you want to include in the RAID set, then press <SpaceBar>. When selected, the drive indicator changes from **READY** to **ONLIN A[X]-[Y]**, where X is the array number, and Y is the drive number.



The information of the selected hard disk drive displays at the bottom of the screen.

- Select all the drives required for the RAID set, then press <Enter>. The configurable array appears on screen.



- Press <F10>, select the configurable array, then press <SpaceBar>.

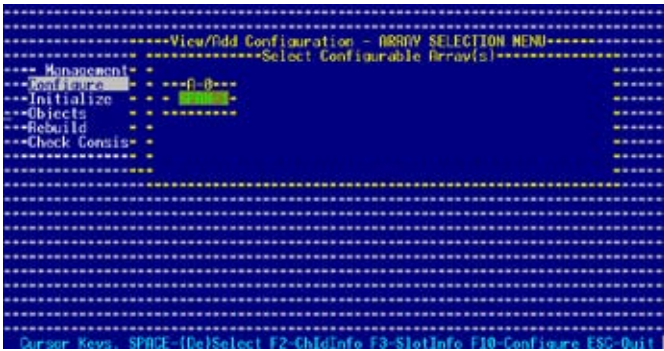

The logical drive information appears including a Logical Drive menu that allows you to change the logical drive parameters.



6.2.4 Initializing the logical drives

After creating the RAID set(s), you must initialize the logical drives. You may initialize the logical drives of a RAID set(s) using the Initialize or Objects command on the Management Menu.

Using the Initialize command

To initialize the logical drive using the **Initialize** command:

1. From the Management Menu, highlight **Initialize**, then press <Enter>.



2. The screen displays the available RAID set(s) and prompts you to select the logical drive to initialize. Use the arrow keys to select the logical drive from the **Logical Drive** selection, then press <Enter>.

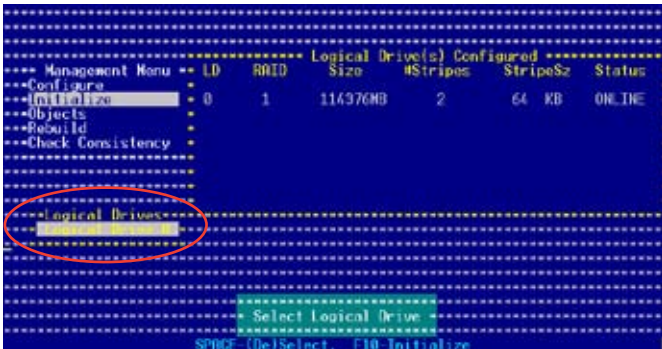

- When prompted, press the <SpaceBar> to select **Yes** from the **Initialize?** dialog box, then press <Enter>. You may also press <F10> to initialize the drive without confirmation.

```
----- Logical Drive(s) Configured -----
Management Menu == LD RAID Size #Stripes StripeSz Status
Configure
Initialize 0 1 114370MB 2 64 KB ON.LINE
Objects
Rebuild
Check Consistency
-----
--Initialize?--
- Yes -
- No -
-----
Logical Drives
-----
Initialize Will Destroy Data On Selected Logical Drive(s)
SPACE (to>Select, F10 Initialize
```



Initializing a logical drive(s) erases all data on the drive.

- A progress bar appears on screen. If desired, press <Esc> to abort initialization.

```
----- Logical Drive(s) Configured -----
Management Menu == LD RAID Size #Stripes StripeSz Status
Configure
Initialize Logical Drives In Progress-----ON.LINE
Objects
Rebuild Array Initialization Under Progress. Press ESC to ABORT
Check C
-----
- 16 % Completed
-----
Logical
-----
SPACE (to>Select, F10 Initialize
```

- When initialization is completed, press <Esc>.

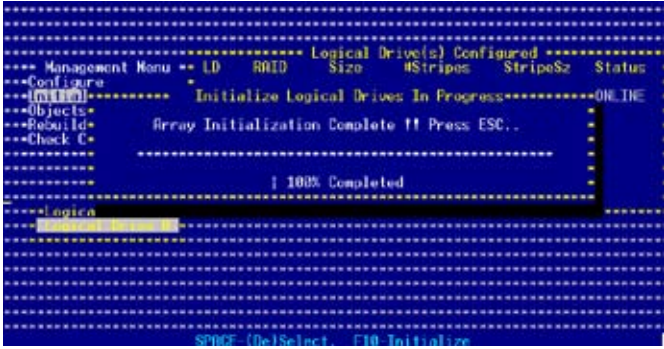

Using the Objects command

To initialize the logical drives using the **Objects** command:

- From the Management Menu, highlight **Objects**, then press <Enter>.

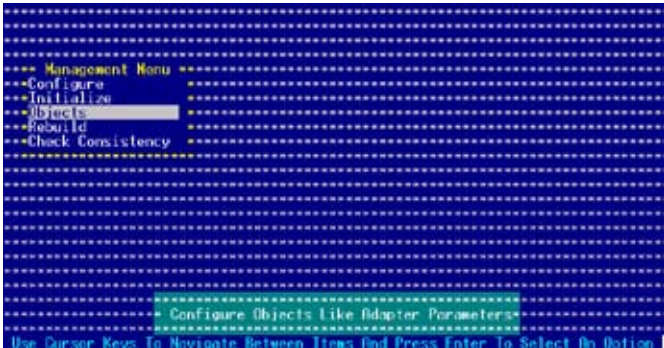

2. Select **Logical Drive** from the **Objects** sub-menu, then press <Enter>.

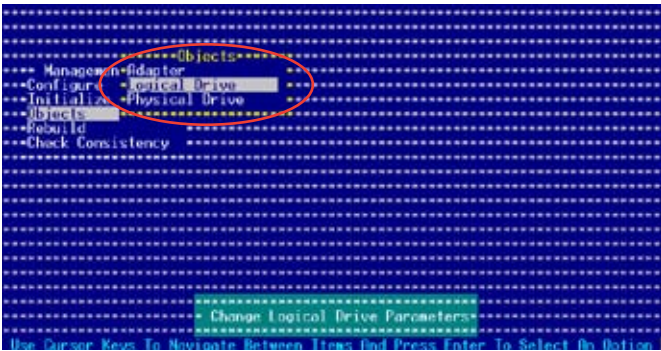

3. Select the logical drive to initialize from the **Logical Drives** sub-menu, then press <Enter>.

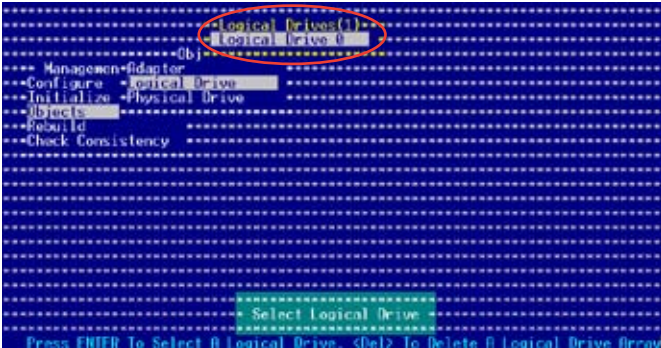

4. Select **Initialize** from the pop-up menu, then press <Enter> to start initialization.

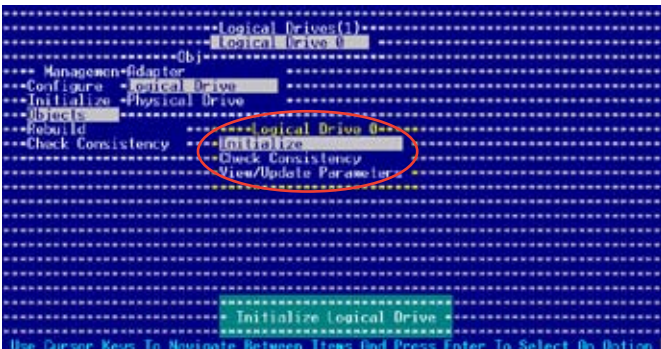

6.2.5 Rebuilding failed drives

You can manually rebuild failed hard disk drives using the **Rebuild** command in the Management Menu.

To rebuild a failed hard disk drive:

1. From the Management Menu, highlight **Rebuild**, then press <Enter>.



2. The **PHYSICAL DRIVES SELECTION MENU** displays the available drives connected to the SATA ports. Select the drive you want to rebuild, then press <SpaceBar>.



- After selecting the drive to rebuild, press <F10>. The indicator for the selected drive now shows **RBLD**.

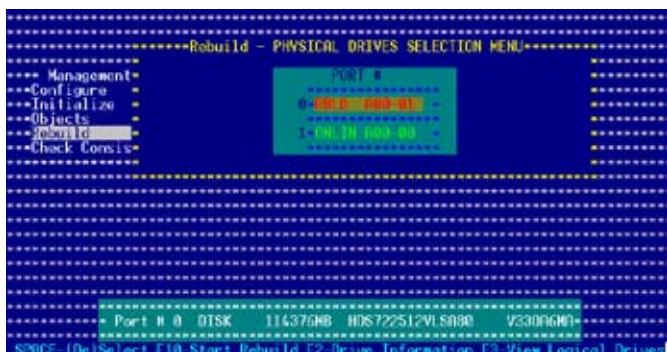

- When prompted, press <Y> to to rebuild the drive.

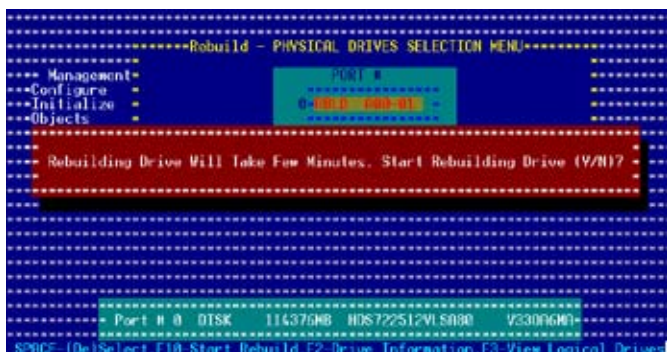

- When rebuild is complete, press any key to continue.

6.2.6 Checking the drives for data consistency

You can check and verify the accuracy of data redundancy in the selected logical drive. The utility can automatically detect and/or detect and correct any differences in data redundancy depending on the selected option in the **Objects > Adapter** menu.



The Check Consistency command is available only for logical drives included in a RAID 1 set.

Using the Check Consistency

To check data consistency using the Check Consistency command:

1. From the Management Menu, select Check Consistency, then press <Enter>.

```
----- Management Menu -----
*Configure
*Initialize
*Objects
*Rebuild
*Check Consistency
-----

----- Check Consistency Of logical Drive(s) -----
Use Cursor Keys To Navigate Between Items And Press Enter To Select An Option
```

2. The screen displays the available RAID set(s) and prompts you to select the logical drive to check. Use the arrow keys to select the logical drive from the **Logical Drive** selection, then press <Enter>.

```
----- Management Menu -----
*Configure
*Initialize
*Objects
*Rebuild
*Check Consistency
-----

----- Logical Drive(s) Configured -----
----- Logical Drives -----
----- Select Logical Drive -----
SPACE (to) Select, F10 Check Consistency
```

LD	RAID	Size	#Stripes	StripeSz	Status
0	1	114376MB	2	64 KB	ONLINE

- When prompted, press the <SpaceBar> to select **Yes** from the **Consistency Check** dialog box, then press <Enter>. You may also press <F10> to check the drive consistency.

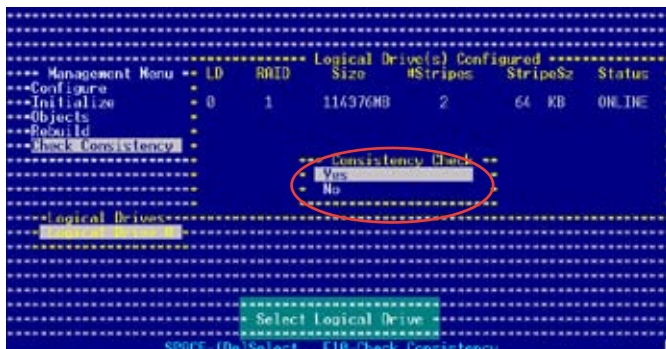

A progress bar appears on screen.

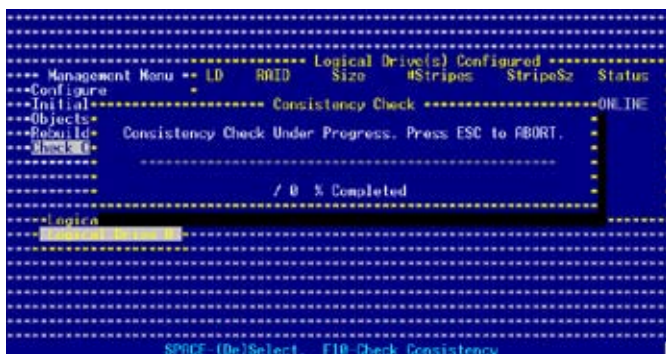

- While checking the disk consistency, press <Esc> to display the following options.
 - Stop** - Stops the consistency check. The utility stores the percentage of disk checked, When you restart checking, it continues from the last percentage completed rather than from zero percent.
 - Continue** - Continues the consistency check.
 - Abort** - Aborts the consistency check. When you restart checking, it continues from zero percent.
- When checking is complete, press any key to continue.

Using the Objects command

To check data consistency using the **Objects** command:

1. From the Management Menu, select **Objects**, then select **Logical Drive** from the menu.
2. Use the arrow keys to select the logical drive you want to check, then press <Enter>.
3. Select **Check Consistency** from the pop-up menu, then press <Enter>.
4. When prompted, press <Y> to check the drive.
5. When checking is complete, press any key to continue.

6.2.7 Deleting a RAID configuration

To delete a RAID configuration:

1. From the Management Menu, select **Configure > Clear Configuration**, then press <Enter>.



2. When prompted, press the <SpaceBar> to select **Yes** from the **Clear Configuration?** dialog box, then press <Enter>.

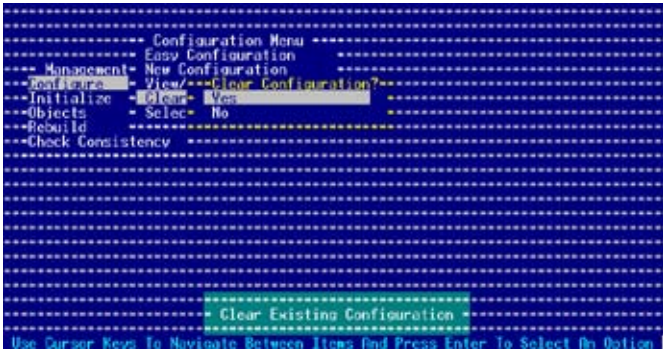

The utility clears the current array.

3. Press any key to continue.

6.2.8 Selecting the boot drive from a RAID set

You must have created a new RAID configuration before you can select the boot drive from a RAID set. Refer to the **Creating a RAID set: Using New Configuration** section for details.

To select the boot drive from a RAID set:

1. From the Management Menu, select **Configure > Select Boot Drive**, then press <Enter>.

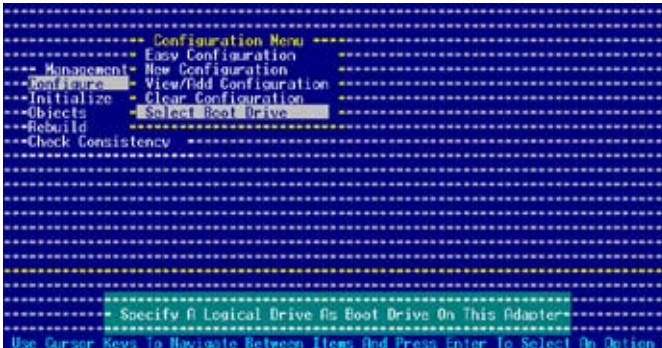

2. When prompted, press the <SpaceBar> to select the bootable logical drive from the list, then press <Enter>.

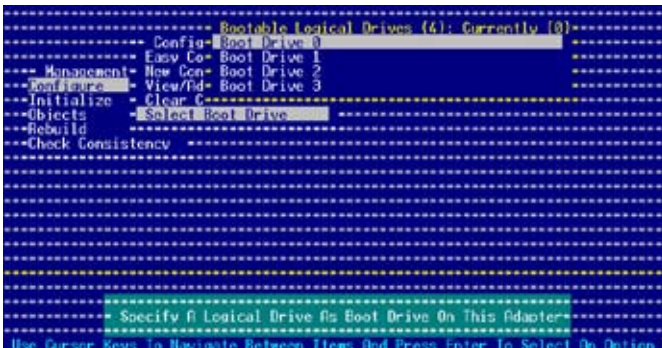

3. The logical drive is selected as boot drive. Press any key to continue.

6.2.9 Enabling the WriteCache

You may enable the RAID controller's **WriteCache** option to improve the data transmission performance.



When you enable WriteCache, you may lose data when a power interruption occurs while transmitting or exchanging data among the drives.

To enable WriteCache:

1. From the Management Menu, select **Objects > Adapter**, then press <Enter> to display the adapter properties.
2. Select **WriteCache**, then press <Enter> to turn the option **On** (enabled).



3. When finished, press any key to continue.

6.3 Global Array Manager

You may also create a RAID set(s) in Windows® operating environment using the Global Array Manager (GAM) application. The GAM application is available from the motherboard support CD.



Refer to the GAM user guide in the motherboard support CD for details.

6.4 Adaptec SCSISelect(TM) Utility! (P5MT-S model only)

The Adaptec SCSISelect(TM) Utility allows you to create RAID 0, 1, and 0+1 set(s) from SCSI hard disk drives connected to the SCSI connector supported by the Adaptec embedded SCSI controller.

To enter the Adaptec SCSISelect(TM) Utility:

1. Turn on the system after installing all the SCSI hard disk drives.
2. During POST, the Adaptec SCSI BIOS automatically detects the installed SCSI hard disk drives and displays any existing RAID set(s). Press <Ctrl><A> to enter the utility.

```
Adaptec SCSI BIOS v4.30
Copyright 2003 Adaptec, Inc. All Rights Reserved.
*** Press <Ctrl><A> for SCSISelect(TM) Utility! ***
Slot Ch ID LUN Vendor Product Size Bus Status
-----
00 A 0 0 SEAGATE ST310432LC 19GB 16
00 A 1 0 SEAGATE ST310432LC 19GB 16
00 A 2 0 SEAGATE ST310432LC 19GB 16
00 A 11 0 SDA GEN310 8
00 B 15 0
```

3. The utility auto-detects the available SCSI channels. Select the SCSI channel, then press <Enter>.

```
-----
AIC-7902 A at slot 00 09:02:00
AIC-7902 B at slot 00 09:02:01
-----
<Arrows> move cursor, <Enter> to select option, <Esc> to exit (**default)
```

6.4.1 Configuring the SCSI controller

You need to configure the SCSI controller before creating a RAID set. After selecting the SCSI channel to use, the utility prompts you to select from the available options. Use the arrow keys to select **Configure/View SCSI Controller Settings**, then press <Enter>.



6.4.2 Enabling the HostRAID controller

To enable the Adaptec HostRAID controller:

1. Use the arrow keys to select the **HostRAID** item in the Configuration section.
2. Press <Enter> to set the item to **Enabled**.

```
----- AIC-7902 A at slot 00, 09:02:00 -----
-- Configuration
-- SCSI Bus Interface Definitions
-- SCSI Controller ID ..... 7
-- SCSI Controller Part#: ..... Enabled
-- SCSI Controller Termination ..... Enabled
-- Additional Options
-- Boot Device Configuration ..... Press <Enter>
-- SCSI Device Configuration ..... Press <Enter>
-- Advanced Configuration ..... Press <Enter>
-- HostRAID ..... Enabled
--
-- <F6> - Reset to SCSI Controller Defaults
--
-- BIOS Information
--
-- Interrupt (IRQ) Channel ..... 11
-- I/O Port Addresses ..... D000h, C800h
--
-- (Arrows) move cursor, <Enter> to select option, <Esc> to exit (**default)
```

3. Press <Esc> to exit.
4. When the utility prompts you to save the changes, select **Yes**, then press <Enter>.

```
** Save Changes Made? **
*       Yes       *
*       No       *
*****
```

The screen returns to the options menu.

```
----- AIC-7902 A at slot 00, 09:02:00 -----
--
-- Would you like to configure the SCSI controller, configure
-- the HostRAID settings, or run the SCSI Disk Utilities?
-- Select the option and press <Enter>.
--
-- Options
-- Configure/View SCSI Controller Settings
-- Configure/View HostRAID Settings
-- SCSI Disk Utilities
--
-- (Arrows) move cursor, <Enter> to select option, <Esc> to exit (**default)
```

6.4.3 Creating a RAID 0 set (Stripe)

To create a RAID 0 set for Performance:

1. After enabling the HostRAID, the utility returns to the initial menu. Use the arrow keys to select **Configure/View HostRAID Settings**, then press <Enter>.



2. The utility displays the installed SCSI hard disk drives status and menu options. When available, the HDD status shows **Free**. Press <C>.

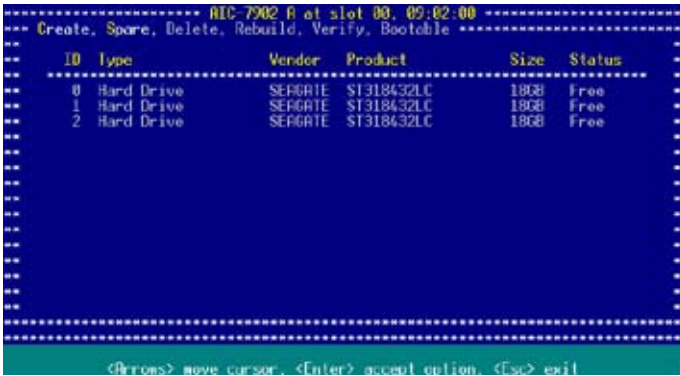

The utility does not display an installed SCSI HDD(s) with an existing RAID configuration or is part of an existing RAID set. Use the SCSI Disk Utilities to reformat the HDD(s), or use the previous RAID card to clear the RAID configuration on the HDD(s).

3. Select **RAID-0 (High Performance, No Fault Tolerance)** from the **Select RAID Type** menu, then press <Enter>.

```
----- AIC-7902 B at slot 00, 09:02:00 -----
Create RAID
-----
ID Vendor Product Size
-----
0 SEAGATE ST318432LC 18GB
1 SEAGATE ST318432LC 18GB
2 SEAGATE ST318432LC 18GB

----- Select RAID Type -----
RAID-0 (High Performance, No Fault Tolerance)
RAID-1 (Fault Tolerance)
RAID-10 (Fault Tolerance, High Performance)
-----

***** Striping Requirements *****
***** Min 2 drives, Max 4 drives *****
-----

<Arrows> move cursor, <Enter> accept option, <Esc> exit
```



Refer to the **Striping Requirements** note at the bottom of the screen to determine the number of hard disk drives required for the selected RAID type.

4. Use the arrow keys to select a RAID set member, then press <SpaceBa> to mark. An **X** mark appears after the selected HDD.
5. Follow the step 4 to select the other members of the RAID set, then press <Enter> when finished.

```
----- AIC-7902 B at slot 00, 09:02:00 -----
RAID 0: Select RAID members
-----
ID Vendor Product Size
-----
0 SEAGATE ST318432LC 18GB X
1 SEAGATE ST318432LC 18GB X
2 SEAGATE ST318432LC 18GB X
-----

<Space> select drives
<Arrows> move cursor, <Enter> accept option, <Esc> exit
```

6. Select the stripe size from the menu, then press <Enter>.

```
*** Select stripe size ***
* 16-KB *
* 32-KB *
* 64-KB *
*****
```



For server systems, we recommend that you use a lower array block size. For multimedia computer systems used mainly for audio and video editing, we recommend a higher array block size for optimum performance.

7. When prompted, use the keyboard to assign a name for the RAID 0 set, then press <Enter>.

```
***** Assign RAID Name *****
* Enter 1 to 15 alphabetic or numeric *
* characters. Press <Enter> when finished. *
*                                     *
* RAID0 *
*                                     *
*****
```

8. If you want to make the array bootable, select **Yes** from the menu, then press <Enter>.

```
*****
* Do you want to make *
* this array as bootable? *
*                       *
*   Yes *
*   No  *
*                       *
*****
```

9. When prompted to create the RAID 0 set, select **Yes**, then press <Enter>.

```
*** Create Array? ***
* Yes *
* No  *
*****
```



The utility erases all data from the selected hard disk drives. Make sure to backup all important data before creating a RAID set.

A **Build Complete** message appears to indicate that you have successfully created the RAID 0 set.

```
*****
* Build Completed. *
*****
```

10. The screen displays the information on the created RAID set. Press <Esc> to exit the utility.

```
----- RAID-7902 A at slot 00, 09:02:00 -----
Create, Spare, Delete, Rebuild, Verify, Bootable
-----
ID  Type          Vendor  Product      Size  Status
B  0  Striped (R0)    HPPIEC  ICHSR        55GB  Optimal
-----
(Arrows) move cursor, (Enter) accept option, (Esc) exit
```

6.4.4 Creating a RAID 1 set (Mirror)

To create a RAID 1 set for Fault Tolerance:

1. Follow steps 1 to 2 of the **Creating a RAID 0** set section.
2. Select **RAID-1 (Fault Tolerance)** from the Select RAID Type menu, then press <Enter>.

```
----- RAID-7902 A at slot 00, 09:02:00 -----
Create RAID
-----
ID  Vendor  Product      Size
0  SEAGATE ST318432LC  186B
1  SEAGATE ST318432LC  186B
2  SEAGATE ST318432LC  186B
-----
Select RAID Type
RAID 0 (High Performance, No Fault Tolerance)
RAID 1 (Fault Tolerance)
RAID 10 (Fault Tolerance, High Performance)
-----
***** Mirroring Requirements *****
***** Min 2 drives, Max 2 drives *****
-----
(Arrows) move cursor, (Enter) accept option, (Esc) exit
```



Refer to the **Mirroring Requirements** note at the bottom of the screen to determine the number of hard disk drives required for the selected RAID type.

3. Use the arrow keys to select a RAID set member, then press <SpaceBar> to mark. An **X** mark appears after the selected HDD.
4. Follow step 3 to select the other members of the RAID set, then press <Enter> when finished.

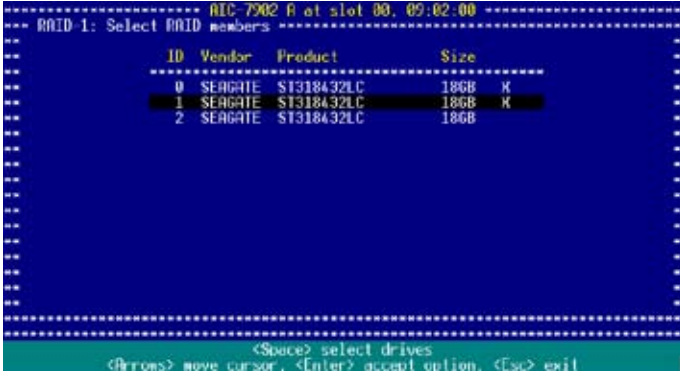

5. Select **Create new RAID-1** from the RAID-1 Build Option menu, then press <Enter>. Refer to the options description below.



- **Create a New RAID-1** - The default option. Select this option when creating a new RAID 1 set.
- **Copy from (0) to (1)** - Select this option when you want to copy the source drive contents to a target drive, provided that the source is equal to or smaller than the target drive.
- **Copy from (1) to (0)** - Select this option when you want to copy the source drive contents to a target drive, provided that the source is larger than the target drive.

6.4.5 Creating a RAID 10 set (Stripe+Mirror)

To create a RAID 10 set for Fault Tolerance and Performance:

1. After enabling the HostRAID, the utility returns to the initial menu. Use the arrow keys to select **Configure/View HostRAID Settings**, then press <Enter>.



2. The utility displays the SCSI hard disk drives installed in your computer and the menu options. Press <C>.

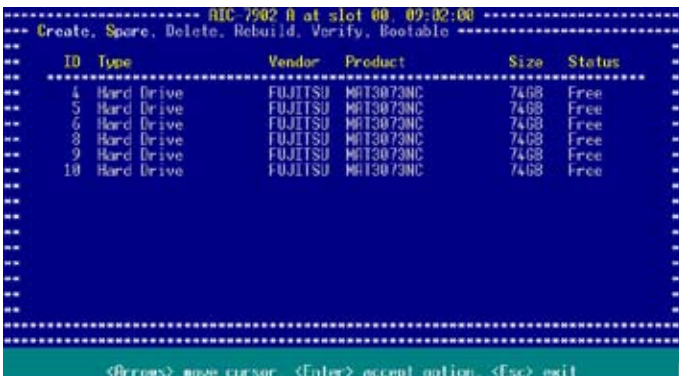

3. Select **RAID-10 (Fault Tolerance, High Performance)** from the **Select RAID Type** menu, then press <Enter>.

```

----- RAID 7902 A at slot 00, 09:02:00 -----
Create RAID
-----
ID Vendor Product Size
-----
4 FUJITSU MAT3073NC 74GB
5 FUJITSU MAT3073NC 74GB
6 FUJITSU MAT3073NC 74GB
8 FUJITSU MAT3073NC 74GB
9 FUJITSU MAT3073NC 74GB
-----
Select RAID Type
-----
RAID-0 (High Performance, No Fault Tolerance)
RAID-1 (Fault Tolerance)
RAID-10 (Fault Tolerance, High Performance)
-----
Striping/Mirroring Requirements
-----
Min 4 drives, Max 4 drives.
-----
<Arrows> move cursor, <Enter> accept option, <Esc> exit

```



Refer to the **Striping/Mirroring Requirements** note at the bottom of the screen to determine the number of hard disk drives required for the selected RAID type.

4. Use the arrow keys to select a RAID set member, then press <SpaceBar> to mark. An **X** mark appears after the selected HDD.
5. Follow the step 4 to select the other members of the RAID set, then press <Enter> when finished.

```

----- RAID 7902 A at slot 00, 09:02:00 -----
RAID 10: Select RAID members
-----
ID Vendor Product Size
-----
4 FUJITSU MAT3073NC 74GB X
5 FUJITSU MAT3073NC 74GB X
6 FUJITSU MAT3073NC 74GB X
8 FUJITSU MAT3073NC 74GB X
9 FUJITSU MAT3073NC 74GB
10 FUJITSU MAT3073NC 74GB
-----
<Space> select drives
-----
<Arrows> move cursor, <Enter> accept option, <Esc> exit

```

6. Select the stripe size from the menu, then press <Enter>.

```
*** Select stripe size ***
*          16-KB          *
*          32-KB          *
*          64-KB          *
*****
```



For server systems, we recommend that you use a lower array block size. For multimedia computer systems used mainly for audio and video editing, we recommend a higher array block size for optimum performance.

7. When prompted, use the keyboard to assign a name for the RAID 10 set, then press <Enter>.

```
***** Assign RAID Name *****
- Enter 1 to 15 alphabetic or numeric
- characters. Press <Enter> when finished.
-
- 7902
-
*****
```

8. If you want to make the array bootable, select **Yes** from the menu, then press <Enter>.

```
*****
* Do you want to make
* this array as bootable?
*
*          Yes          *
*          No           *
*****
```

9. When prompted to create the RAID 10 set, select <Yes>, then press <Enter>.

```
*** Create Array? ***
*          Yes          *
*          No           *
*****
```



The utility erases all data from the selected hard disk drives. Make sure to backup all important data before creating a RAID set.

A **Build Complete** message appears to indicate that you have successfully created the RAID 10 set.

```
*****
*          Build Completed.          *
*****
```



6.4.6 Adding a spare drive to a RAID 10 set

To add a spare drive to a RAID 10 set:

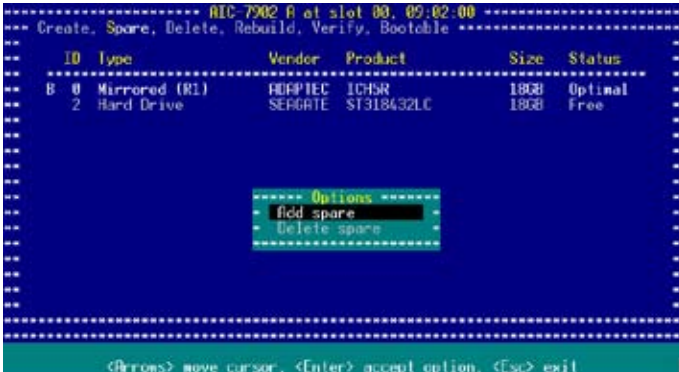
1. Press <S> from the **Configure/View Host RAID Settings** menu.
2. Select **Add Spare** from the Options menu, then press <Enter>.

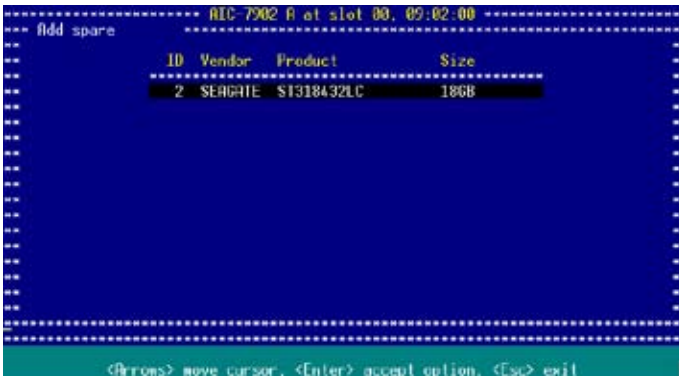

3. Use the arrow keys to select the spare drive from the list, then press <Enter>.



4. When a confirmation dialogue box appears, select **Yes**, then press <Enter>.



- The screen displays the information on the added spare drive. Press <Esc> to exit the utility.

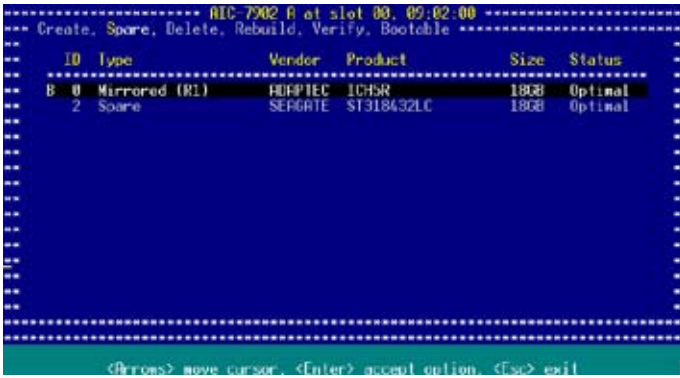

6.4.7 Deleting a RAID 10 set spare drive

To delete a RAID 10 set spare drive:

- From the utility main menu, press <S>, select **Delete Spare** from the Options menu, then press <Enter>.

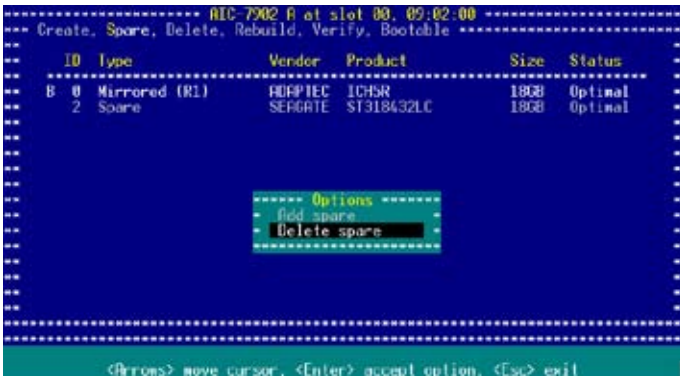

2. The screen displays the available spare drive(s). Use the arrow keys to select the spare drive you want to delete, then press <Enter>.

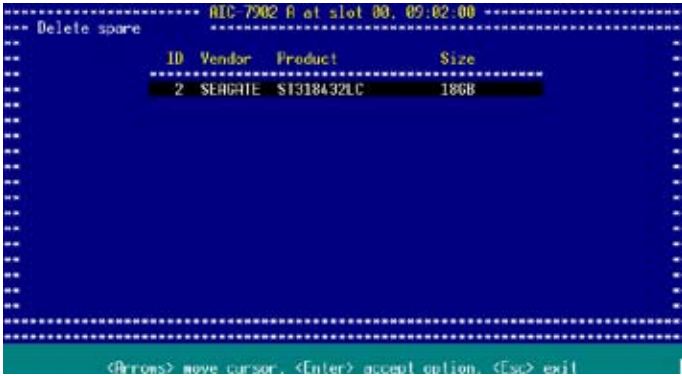

3. When a confirmation dialogue box appears, select **Yes**, then press <Enter> to delete the spare drive.
4. Press <ESC> to exit the utility.



6.4.9 Rebuilding a RAID set



The rebuild option is available only for RAID 1 and RAID 10 sets.

To rebuild a RAID set:

1. From the main menu, select the RAID set you want to rebuild, then press <Enter>.

```
----- RAID-7502 B at slot 00, 09:02:00 -----
* Create, Spare, Delete, Rebuild, Verify, Bootable *
-----
ID  Type          Vendor- Product          Size  Status
-----
 4  Stripe/Mirror (R10) ADAPTEC  7502             147GB Optimal
 9  Hard Drive     FUJITSU  MAT3073NC        74GB  Free
10  Hard Drive     FUJITSU  MAT3073NC        74GB  Free
-----
<Arrow> move cursor, <Enter> accept option, <Esc> exit
```

2. Press <R>.



While rebuilding the array, you can press <Esc> to stop. A pop-up menu appears for confirmation. Select **Yes** to stop rebuilding and return to the main menu.

A **Build/Rebuild Completed** message appears on screen to indicate that you have successfully rebuilt the array.

3. Press any key to return to the main menu.

6.4.10 Verifying a RAID set hard disk drive

To verify a RAID set hard disk drive:

1. Select **SCSI Disk Utilities** from the main menu options, then press <Enter>.



2. The screen displays the RAID set drives. Use the arrow keys to select the hard disk drive you want to verify, then press <Enter>.

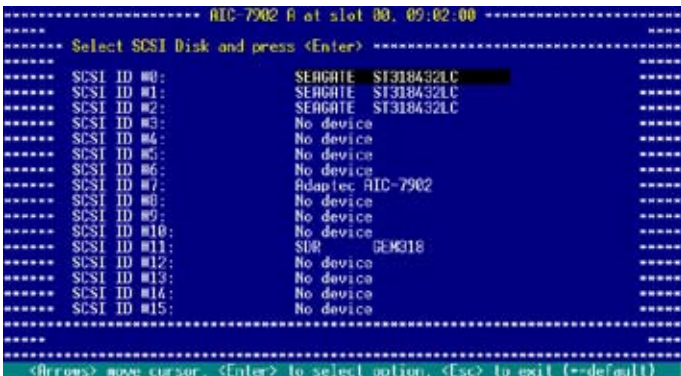

3. Select **Verify Disk Media** from the menu, then press <Enter>.

```
----- HLC-7902 H at slot 00, 09:02:00 -----
Select SCSI Disk and press <Enter>
-----
SCSI ID # 0: SEAGATE ST318432LC
Firmware: 0022
Capacity: 18GB

-----
- Format Disk
- Verify Disk Media
-----

SCSI ID #14: No device
SCSI ID #15: No device

-----
<Arrows> move cursor, <Enter> to select option, <Esc> to exit (=default)
```



You can also use the **SCSI Disk Utilities** to format the hard disk drive.

4. After verifying the hard disk drive, press <Esc> to exit the utility.

6.4.11 Making a RAID set bootable

To make a RAID set bootable:

1. Select **SCSI Disk Utilities** from the main menu options, then press <Enter>.

```
----- HLC-7902 H at slot 00, 09:02:00 -----
Would you like to configure the SCSI controller, configure
the HostRAID settings, or run the SCSI Disk Utilities?
Select the option and press <Enter>.
-----
Options
-----
Configure/View SCSI Controller Settings
Configure/View HostRAID Settings
SCSI Disk Utilities
-----

-----
<Arrows> move cursor, <Enter> to select option, <Esc> to exit (=default)
```

- Select the RAID set you want to make bootable, then press <Enter>.

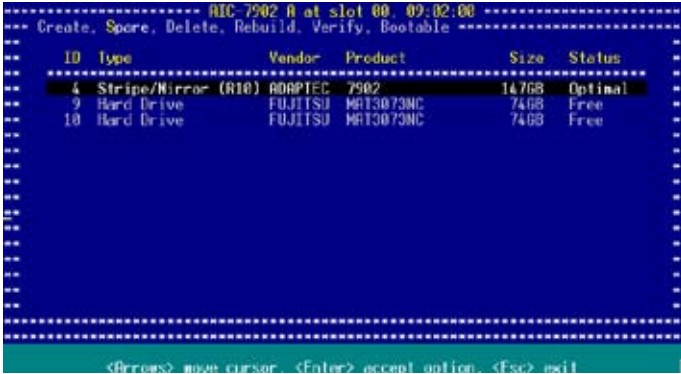

- Press when the RAID set information displays on screen.

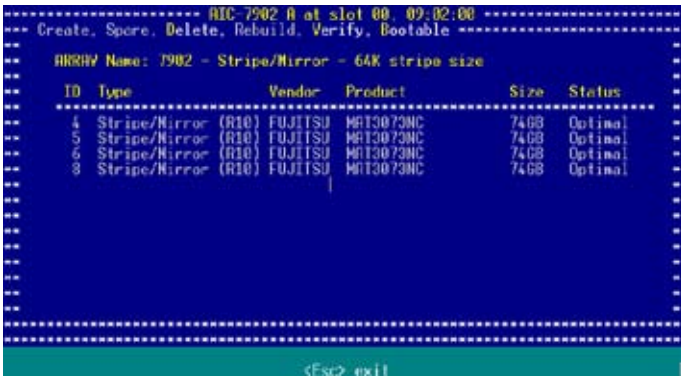

- When prompted, select **Mark bootable**, then press <Enter>.



The letter “B” appears before a bootable RAID set for easy identification.



Chapter 7

This chapter provides information on RAID configurations, RAID driver installation, and LAN driver installation for this motherboard.



ASUS TS300-E3/PA4 & PS4

Download from [Www.Somanuals.com](http://www.somanuals.com). All Manuals Search And Download.

Driver installation

7.1 RAID driver installation

After creating the RAID sets for your server system, you are now ready to install an operating system to the independent hard disk drive or bootable array. This part provides instructions on how to install the RAID controller drivers during OS installation.

7.1.1 Creating a RAID driver disk



You may have to use another system to create the RAID driver disk from the system/motherboard support CD or from the Internet.

A floppy disk with the RAID driver is required when installing Windows® 2000/XP or Red Hat® Enterprise ver. 3.0/SuSE operating system on a hard disk drive that is included in a RAID set. You can create a RAID driver disk in DOS (using the Makedisk application in the support CD).

To create a RAID driver disk in DOS environment:

1. Place the motherboard support CD in the optical drive.
2. Restart the computer, then enter the BIOS Setup.
3. Select the optical drive as the first boot priority to boot from the support CD. Save your changes, then exit the BIOS Setup.
4. Restart the computer.
5. Press any key when prompted to boot from CD.

```
Loading FreeDOS FAT KERNEL GO!  
Press any key to boot from CDROM...
```

The Makedisk menu appears.

```
b) Create ICH7R LSI MegaRAID IDE Driver for RHEL4 64 bit Driver Disk  
c) Create ICH7R LSI MegaRAID IDE Driver for RHEL4 32 bit Driver Disk  
d) Create ICH7R LSI MegaRAID IDE Driver for SLES9 SP1 Driver Disk  
e) Create ICH7R LSI MegaRAID IDE Driver for SLES9 SP1 64 bit Driver Disk  
f) Create ICH7R LSI MegaRAID IDE Driver for SUSE93 Driver Disk  
g) Create ICH7R LSI MegaRAID IDE Driver for Win 32/64 bit Driver Disk  
h) Create ICH7R Intel Matrix Storage for Win32 driver disk  
i) Create ICH7R Intel Matrix Storage for Win64 driver disk  
j) Create LSI Logic Fusion-MPT MiniPort for Win2K 32 bit driver  
k) Create LSI Logic Fusion-MPT MiniPort for Win2K 32/64 bit driver  
l) Create LSI Logic Fusion-MPT MiniPort for RHEL3.0AS driver  
m) Broadcom Firmware Update  
Please choose a number:
```

6. Place a blank, high-density floppy disk to the floppy disk drive, then select the type of RAID driver disk you want to create by typing the number before the option
7. Press <Enter>.
8. Follow screen instructions to create the driver disk.



For systems with Red Hat® Enterprise versions that are not listed in the Makedisk menu, explore the support CD and copy the RAID driver disk from the following path: `\Drivers\Chipset\CHLS\Driver\Linux`.

7.1.2 Installing the RAID controller driver

Windows® 2000/2003 Server OS

During Windows® 2000/2003 Server OS installation

To install the RAID controller driver when installing Windows® 2000/2003 Server OS:

1. Boot the computer using the Windows® 2000/2003 Server installation CD. The **Windows® 2000/2003 Setup** starts.



2. Press <F6> when the message "Press F6 if you need to install a third party SCSI or RAID driver..." appears at the bottom of the screen.
3. When prompted, press <S> to specify an additional device.



4. Insert the RAID driver disk you created earlier to the floppy disk drive, then press <Enter>.

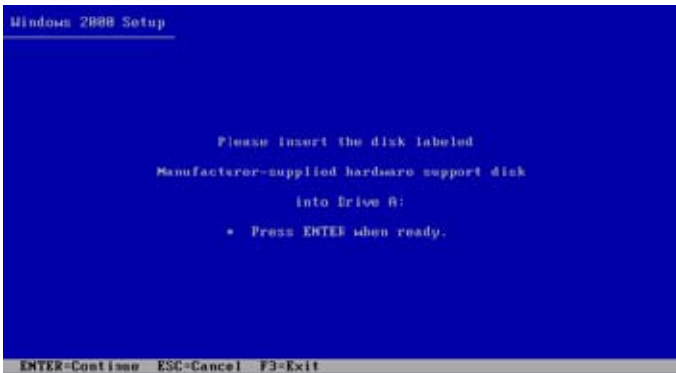

5. Select the RAID controller driver from the list, then press <Enter>.

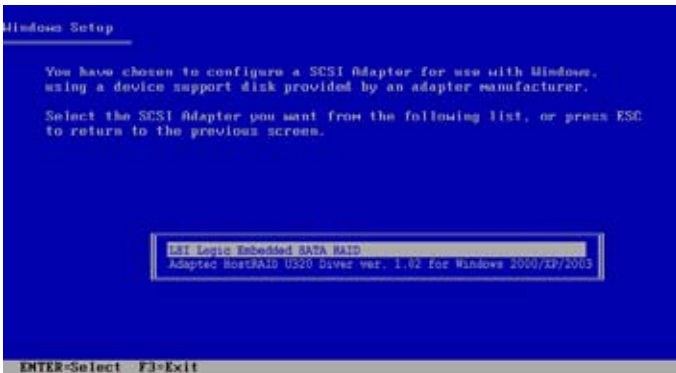

- For Intel® ICH7R LSI Logic Embedded SATA RAID driver, select **LSI Logic Embedded SATA RAID**.
 - For Adaptec® AIC-7901X SCSI RAID driver, select **Adaptec HostRAID U320 Diver ver. 1.02 for Windows 2000/XP/2003**.
6. The Windows® 2000/2003 Setup loads the RAID controller drivers from the RAID driver disk. When prompted, press <Enter> to continue installation.
 7. Setup then proceeds with the OS installation. Follow screen instructions to continue.

To an existing Windows® 2000/2003 Server OS

To install the RAID controller driver on an existing Windows® 2000/2003 Server OS:

1. Restart the computer, then log in with **Administrator** privileges.
2. Windows® automatically detects the RAID controller and displays a **New Hardware Found** window. Click **Cancel**.
3. Right-click the **My Computer** icon on the Windows® desktop , then select **Properties** from the menu.
4. Click the **Hardware** tab, then click the **Device Manager** button to display the list of devices installed in the system.

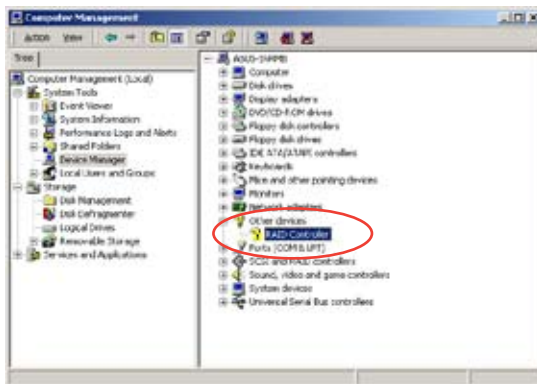

5. Right-click the **RAID controller** item, then select **Properties**.
6. Click the **Driver** tab, then click the **Update Driver** button.
7. The **Upgrade Device Driver Wizard** window appears. Click **Next**.
8. Insert the RAID driver disk you created earlier to the floppy disk drive.
9. Select the option "**Search for a suitable driver for my device (recommended)**", then click **Next**.
10. The wizard searches the RAID controller drivers. When found, click **Next** to install the drivers.
11. Click **Finish** after the driver installation is done.



To verify the RAID controller driver installation:

1. Right-click the **My Computer** icon on the Windows® desktop , then select Properties from the menu.
2. Click the **Hardware** tab, then click the **Device Manager** button.
3. Click the “+” sign before the item SCSI and RAID controllers.

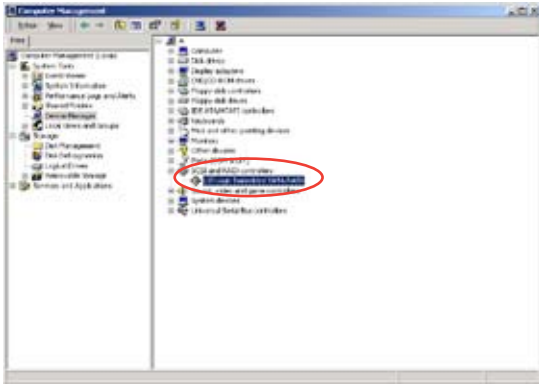

- For P5MT model, the **LSI Logic Embedded SATA RAID** item should appear.
 - For P5MT-S model, the **Adaptec HostRAID U320 Diver ver. 1.02 for Windows 2000/XP/2003** item should appear.
4. Right-click the **RAID controller driver** item, then select Properties from the menu.
 5. Click the **Driver** tab, then click the **Driver Details** button to display the RAID controller drivers.
 6. Click **OK** when finished.

Red Hat® Enterprise ver. 3.0

To install the Intel® ICH7R LSI Logic Embedded SATA RAID controller driver when installing Red Hat® Enterprise ver. 3.0 OS:

1. Boot the system from the Red Hat® Installation CD.



2. At the `boot:`, type `linux dd`, then press <Enter>.

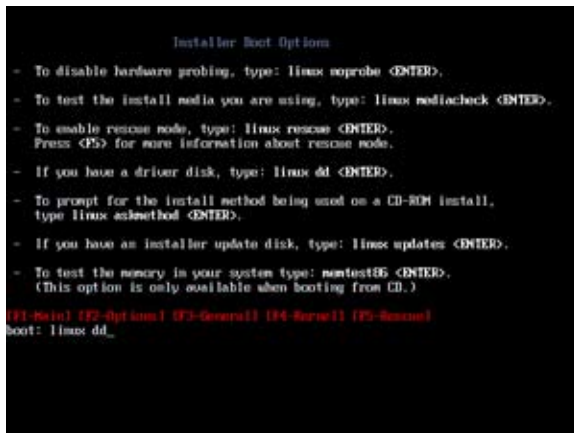

3. Select **Yes** using the <Tab> key when asked if you have the driver disk. Press <Enter>

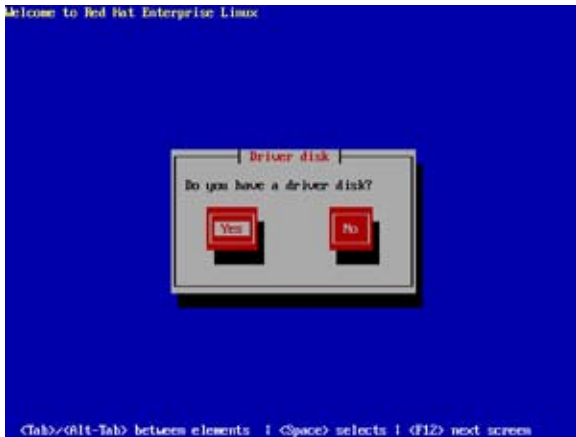

4. Select **fd0** using the <Tab> key when asked to select the driver disk source. Press <Tab> to move the cursor to **OK**, then press <Enter>.



- When prompted, insert the Red Hat® Enterprise ver. 3.0 RAID driver disk to the floppy disk drive, select **OK**, then press <Enter>.



The drivers for the RAID controller are installed to the system.

- When asked if you will load additional RAID controller drivers:
 - For P5MT model, select **No**, then press <Enter>
 - For P5MT-S model, select **Yes**, then install the additional RAID controller drivers (for Adaptec AIC-7901 PCI-X SCSI controller).

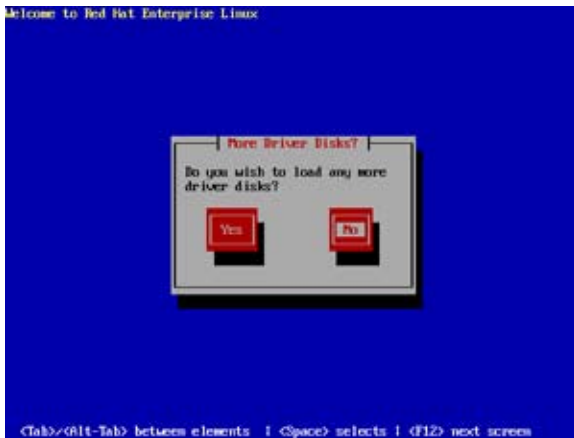

- Follow screen instructions to continue the OS installation.

SuSE Linux

To install the RAID controller driver when installing SuSE Linux OS:

1. Boot the system from the SuSE Installation CD.
2. Select **Installation** from the Boot Options menu, then press <Enter>.

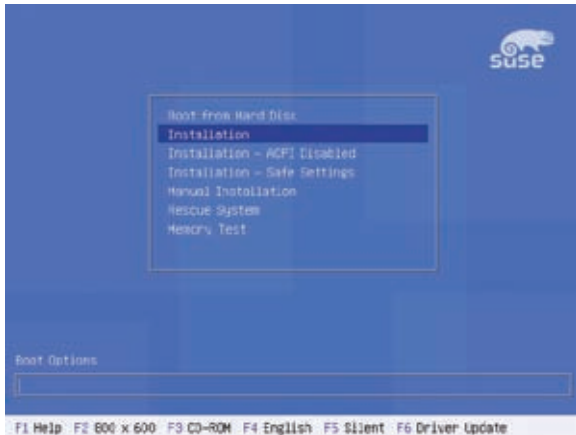

3. A message instructs you to prepare the RAID driver disk. Press <F6>.

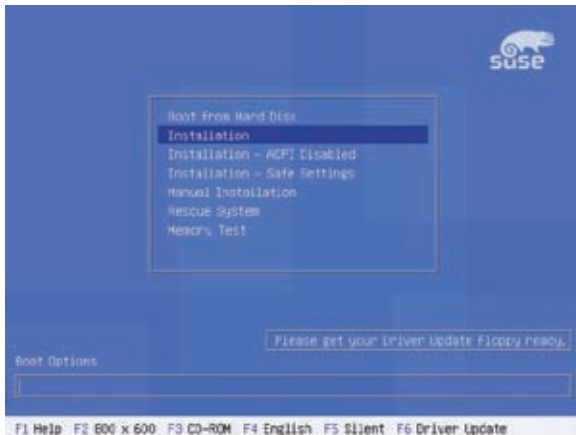

- When prompted, insert the RAID driver disk to the floppy disk drive, then press <Enter>.

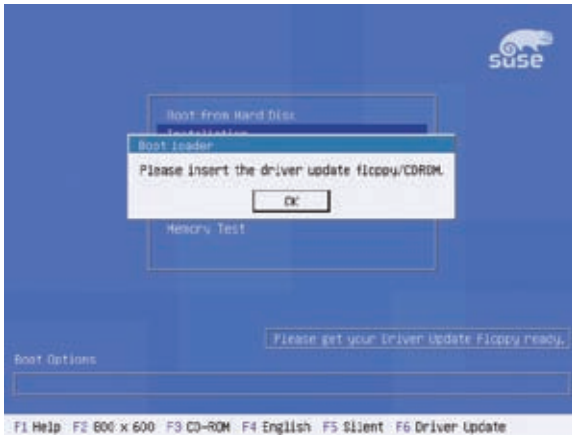

- When prompted, select the floppy disk drive (fd0) as the driver update medium, select **OK**, then press <Enter>.

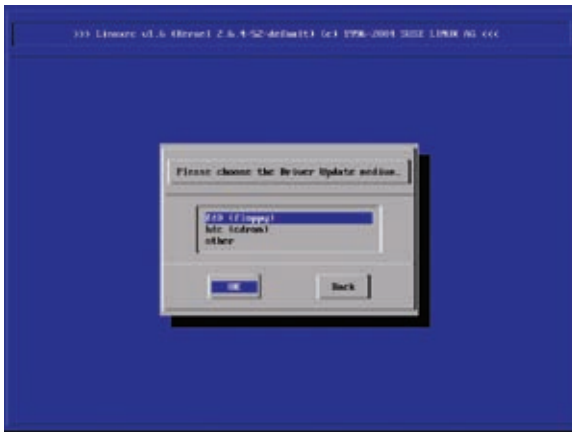

The drivers for the RAID controller are installed to the system.

7.2 LAN driver installation

This section provides instructions on how to install the Broadcom® Gigabit LAN controller drivers.

7.2.1 Windows® 2000/2003 Server

To install the Broadcom® Gigabit LAN controller driver on a Windows® 2000/2003 Server OS:

1. Restart the computer, then log on with Administrator privileges.
2. Insert the motherboard/system support CD to the optical drive. The CD automatically displays the Drivers menu if Autorun is enabled in your computer.



- Windows® automatically detects the LAN controllers and displays a **New Hardware Found** window. Click **Cancel** to close this window.
- If **Autorun** is NOT enabled in your computer, browse the contents of the support CD to locate the file **ASSETUP.EXE** from the BIN folder. Double-click the **ASSETUP.EXE** to run the CD.

3. Click the **Broadcom Lan Driver** option to begin installation.



4. Click **Next** when the InstallShield Wizard window appears. Follow screen instructions to continue installation.

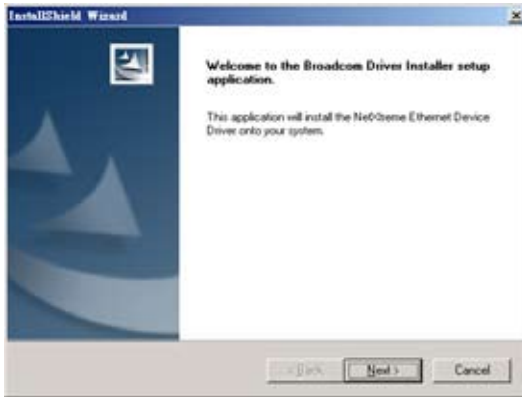

7.2.2 Red Hat® Enterprise ver. 3.0

Follow these instructions when installing the Broadcom® Gigabit LAN controller base driver for the Red Hat® Enterprise ver. 3.0 operating system.

Building the driver from the TAR file



Install first the Kernel Development tools before building the driver from the TAR file.

To build the driver from the TAR file:

1. Create a directory and extract the TAR files:
`tar xvzf bcm5700-<version>.tar.gz`
2. Build the driver `bcm5700.o` as a loadable module for the running kernel:
`cd bcm5700-<version>/src`
`make`
3. Test the driver by loading it:
`insmod bcm5700.o`
4. Install the driver and main page:
`make install`
5. Refer to Red Hat distribution documentation to configure the network protocol and address.

7.3 VGA driver installation

This section provides instructions on how to install the ATI® RAGE XL Video Graphics Adapter (VGA) driver.

7.3.1 Windows® 2000 Server

You need to manually install the ATI® RAGE XL VGA driver on a Windows® 2000 Server operating system.

To install the ATI® RAGE XL VGA driver:

1. Restart the computer, then log on with **Administrator** privileges.
2. Insert the motherboard/system support CD to the optical drive. The support CD automatically displays the **Drivers** menu if Autorun is enabled in your computer.



Windows® automatically detects the LAN controller and displays a **New Hardware Found** window. Click **Cancel** to close this window.

3. Click the item **ATI Rage XL Display Driver** from the **Drivers** menu.



4. The ATI Windows 2000 Driver window appears. Click **Next**. Follow screen instructions to complete installation.



7.3.2 Windows® 2003 Server

The Windows® 2003 Server operating system automatically recognizes the ATI® RAGE XL VGA driver during system installation. There is no need to install an additional driver(s) to support the onboard VGA.

7.3.3 Red Hat® Enterprise ver. 3.0

The Red Hat® Enterprise ver. 3.0 operating system automatically recognizes the ATI® RAGE XL VGA driver during system installation. There is no need to install an additional driver(s) to support the onboard VGA.

7.4 Management applications and utilities installation

The support CD that came with the motherboard package contains the drivers, management applications, and utilities that you can install to avail all motherboard features.



The contents of the support CD are subject to change at any time without notice. Visit the ASUS website (www.asus.com) for updates.

7.4.1 Running the support CD

Place the support CD to the optical drive. The CD automatically displays the **Drivers** menu if Autorun is enabled in your computer.



If **Autorun** is NOT enabled in your computer, browse the contents of the support CD to locate the file **ASSETUP.EXE** from the BIN folder. Double-click the **ASSETUP.EXE** to run the CD.

7.4.2 Drivers menu

The **Drivers** menu shows the available device drivers if the system detects installed devices. Install the necessary drivers to activate the devices.



The screen display and driver options vary under different operating system versions.



7.4.3 Management Software menu

The **Management Software** menu displays the available network and server monitoring applications. Click on an item to install.



7.4.4 Utilities menu

The **Utilities** menu displays the software applications and utilities that the motherboard supports. Click on an item to install.



7.4.5 Contact information

Click the **Contact** tab to display the ASUS contact information. You can also find this information on the inside front cover of this user guide.

Appendix

This section provides information about the power supply unit and a troubleshooting guide for solving common problems when using the barebone server.



A.1 450 W single power supply

A.1.1 General description

The 450 W SSI-type single power supply with universal AC input includes PFC and ATX-compliant output cables and connectors. The power supply has 13 plugs labeled P1 to P13. Take note of the devices to which you should connect the plugs.

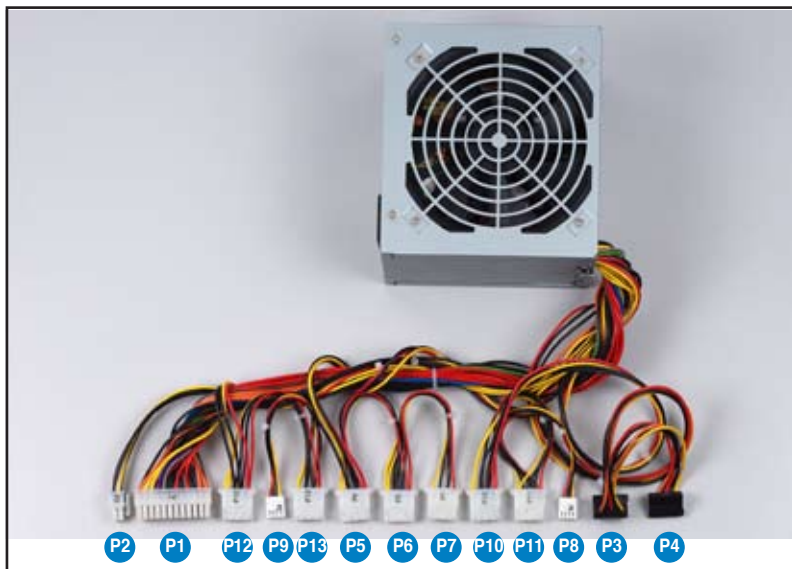

P2	Motherboard 4-pin +12V power connector
P1	Motherboard 24-pin ATX power connector
P12	Peripheral device (available); connect this to the SCSI/SATA backplane
P9	Floppy disk drive
P13	Peripheral device (available)
P5	Peripheral device (available)
P6	Peripheral device (available)
P7	Peripheral device (available); connect this to the SCSI/SATA backplane
P10	Peripheral device (available); optical drive
P11	Peripheral device (available)
P8	Peripheral device (available)
P3	Serial ATA device
P4	Serial ATA device

A.1.2 Specifications

Input Characteristics

Input Voltage Range

Normal Range 110 to 127 V ~ 10 A

Auto Range 200 to 240 V ~ 5 A

Input Frequency Range 50 Hz to 60 Hz

DC Output characteristics

Output Voltage	Max (A)
+3.33V	24
+5V	24
+12V	43
-12V	0.5
-5V	0.5
+5VSB	2.0

A.2 Simple fixes



Some problems that you may encounter are not due to defects on the system or the components. These problems only requires simple troubleshooting actions that you can perform by yourself.

Problem	Action
The power LED on the server or on the monitor do not light up	<ol style="list-style-type: none">1. Check if the power cable is properly connected to the power connector in the system rear panel.2. Make sure that the power cables are connected to a grounded power outlet.3. Press the power button to make sure that the system is turned on.
The keyboard does not work	Check if the keyboard cable is properly connected to the PS/2 keyboard port.
The mouse does not work	Check if the mouse cable is properly connected to the mouse port.
The system does not perform power-on self tests (POST) after it was turned on	<ol style="list-style-type: none">1. Check the memory modules and make sure you installed the DIMMs the system supports.2. Make sure that the DIMMs are properly installed on the sockets.

Problem	Action
The system continuously beeps after it was turned on.	<ol style="list-style-type: none"> <li data-bbox="545 231 907 331">1. Check the memory modules and make sure you installed supported DIMMs. <li data-bbox="545 335 907 467">2. Make sure that the DIMMs are properly installed on the sockets.
The message “Non-system disk or disk error” appears	<ol style="list-style-type: none"> <li data-bbox="545 470 907 539">1. Check if a bootable HDD is active. <li data-bbox="545 542 907 671">2. Check if the HDDs are properly installed.
Network connection not available	<ol style="list-style-type: none"> <li data-bbox="545 675 907 783">1. Make sure that the network cable is connected to the LAN port on the rear panel. <li data-bbox="545 786 907 874">2. Make sure that you have installed the LAN drivers from the support CD.

Free Manuals Download Website

<http://myh66.com>

<http://usermanuals.us>

<http://www.somanuals.com>

<http://www.4manuals.cc>

<http://www.manual-lib.com>

<http://www.404manual.com>

<http://www.luxmanual.com>

<http://aubethermostatmanual.com>

Golf course search by state

<http://golfingnear.com>

Email search by domain

<http://emailbydomain.com>

Auto manuals search

<http://auto.somanuals.com>

TV manuals search

<http://tv.somanuals.com>