



NetCamera NV IP Security Night Vision Camera A02-IPCAM3



MANUAL
A02-IPCAM3_ME01

Where solutions begin

ISO 9001:2000 Certified Company



ITALIANO

Questo prodotto è coperto da garanzia Atlantis Land **Fast-Swap** della durata di 3 anni. Per maggiori dettagli in merito o per accedere alla documentazione completa in Italiano fare riferimento al sito www.atlantis-land.com.

ENGLISH

This product is covered by Atlantis Land 3 years **Fast-Swap** warranty. For more detailed informations please refer to the web site www.atlantis-land.com. For more detailed instructions on configuring and using this device, please refer to the online manual.

FRANCAIS

Ce produit est couvert par une garantie Atlantis Land **Fast-Swap** de 3 ans. Pour des informations plus détaillées, référez-vous svp au site Web www.atlantis-land.com.

DEUTSCH

Dieses Produkt ist durch die Atlantis Land 3 Jahre **Fast-Swap** Garantie gedeckt. Für weitere Informationen, beziehen Sie sich bitte auf Web Site www.atlantis-land.com.

ESPAÑOL

Este producto esta cubierto por Atlantis Land con una garantía **Fast-Swap** de 3 años. Para mayor información diríjase a nuestro sitio Web www.atlantis-land.com.



The award of the information is facultative, but its lack will prevent ATLANTIS LAND® from starting the Guarantee process requested.



Register your product!

www.atlantis-land.com

Registration on the web site **www.atlantis-land.com** within 15 days from the purchase of the product dismiss the customer from showing a valid proof of purchase (Sale Receipt or Invoice) in case of the request of intervention. For further information we invite you to look at our web site at the section WARRANTY.

Copyright

The Atlantis Land logo is a registered trademark of Atlantis Land S.p.A. All other names mentioned may be trademarks or registered trademarks of their respective owners. Subject to change without notice. No liability for technical errors and/or omissions.



INDEX

- Chapter 1 9
 - 1.1 An Overview of NetCamera NV 9
 - 1.2 System Requirements..... 9
 - 1.3 Package Contents..... 10
- Chapter 2 11
 - 2.1 Cautions for NetCamera NV 11
 - 2.2 The Front LEDs..... 12
 - 2.3 The Rear Ports..... 14
 - 2.4 Assembling the Stand and Connecting to a Network..... 16
- Chapter 3 18
 - 3.1 Before Configuration 18
 - 3.1.1 Windows 95/98/ME 19
 - 3.1.2 Windows NT4.0..... 19
 - 3.1.3 Windows 2000..... 19
 - 3.1.4 Windows XP 20
 - 3.2 Default Settings..... 20
 - 3.3 Browser configuration 21
- Chapter 4 24
 - 4.1 Basic Settings 27
 - 4.1.1 System 27
 - Configuration..... 28
 - Firmware 30
 - Others 32
 - 4.1.2 Network 33
 - Ethernet..... 34
 - PPPoE..... 35
 - DDNS 37
 - 4.1.3 User..... 38
 - 4.1.4 Video 39
 - 4.1.5 Monitor 41
 - 4.2 Advanced 42



- 4.2.1 FTP 42
- 4.2.2 Mail..... 44
- 4.2.3 GPIO 46
- 4.2.4 TCP Message 47
- 4.2.5 Breach Manager..... 48
- Chapter 5 50
- 5.1 Support 50
- APPENDIX A: Frequently Asked Questions 51
 - A.1 Using LEDs to Diagnose Problems 51
 - A.1.1 LED Power..... 51
 - A.1.2 LED LAN 51
 - A.2 WEB..... 52
 - A.3 Login 52
 - A.4 General Questions..... 53
- APPENDIX B: Trouble Shooting 55
- APPENDIX C: Adjusting the Camera Focus 59
- APPENDIX D: GPIO 60
- APPENDIX E: Glossary of Terms 66
- APPENDIX F: Technical Features 76

A02-IPCAM3_ME01(V1.0 December 2006)



Copyright Statement

No part of this publication may be reproduced, stored in a retrieval system, or transmitted in any form or by any means, whether electronic, mechanical, photocopying, recording or otherwise without the prior writing of the publisher. Windows™ 98SE/2000/ME/XP are trademarks of Microsoft® Corp. Pentium is trademark of Intel. All copyright reserved.

The Atlantis Land logo is a registered trademark of Atlantis Land SpA. All other names mentioned may be trademarks or registered trademarks of their respective owners. Subject to change without notice. No liability for technical errors and/or omissions.

Wireless LAN, Health and Authorization for use

Radio frequency electromagnetic energy is emitted from Wireless LAN devices. The energy levels of these emissions however are far much less than the electromagnetic energy emissions from wireless devices like for example mobile phones. Wireless LAN devices are safe for use frequency safety standards and recommendations. The use of Wireless LAN devices may be restricted in some situations or environments for example:

- On board of airplanes, or
- In an explosive environment, or
- In case the interference risk to other devices or services is perceived or identified as harmful

In case the policy regarding the use of Wireless LAN devices in specific organizations or environments (e.g. airports, hospitals, chemical/oil/gas industrial plants, private buildings etc.) is not clear, please ask for authorization to use these devices prior to operating the equipment.

Regulatory Information/disclaimers

Installation and use of this Wireless LAN device must be in strict accordance with the instructions included in the user documentation provided with the product. Any changes or modifications made to this device that are not expressly approved by the manufacturer may void the user's authority to operate the equipment. The Manufacturer is not responsible for any radio or television interference caused by unauthorized modification of this device, of the substitution or attachment. Manufacturer and its authorized resellers or distributors will assume no liability for any damage or violation of government regulations arising from failing to comply with these guidelines.



CE Mark Warning

This is a Class B product. In a domestic environment, this product may cause radio interference, in which case the user may be required to take adequate measures.

CE in which Countries where the product may be used freely:

Germany, UK, Italy, Spain, Belgium, Netherlands, Portugal, Greece, Ireland, Denmark, Luxembourg, Austria, Finland, Sweden, Norway and Iceland.

France: except the channel 10 through 13, law prohibits the use of other channels.

CE/EMC Restriction of Liability

The product described in this handbook was designed, produced and approved according to the EMC-regulations and is certified to be within EMC limitations.

If the product is used in an uncertified PC, the manufacturer undertakes no warranty in respect to the EMC limits. The described product in this handbook was constructed, produced and certified so that the measured values are within EMC limitations. In practice and under special circumstances, it may be possible, that the product may be outside of the given limits if it is used in a PC that is not produced under EMC certification. It is also possible in certain cases and under special circumstances, which the given EMC peak values will become out of tolerance. In these cases, the user himself is responsible for compliance with the EMC limits.



Chapter 1

Introduction

This manual is think for an advanced utilization of NetCamera NV; for this reason, you can find explanation of any functions supported by product. For fast configuration, please referee to Quick Start Guide.

1.1 An Overview of NetCamera NV

NetCamera NV is the ideal solution for sending videos, remote video surveillance and for the transmission of images in real-time over your Intranet or the Internet.

NetCamera NV is equipped with a powerful CPU and integrates the robust Linux operating system enabling to integrate, among its many features, automatic movement detection via hardware in MJPEG format with VGA resolution and constant rates of 15 fps; recording not only the video but also the sound.

Its back panel contains 3 pairs of connectors (2 input and 1 output) allowing the camera to communicate with different elements of a building, such as electric doors and light switches or security related devices such as alarms.

Furthermore, thanks its 8 integrated Infrared sensors, the NetCamera NV's automatic Day/Night functionality will change to Infrared mode as it becomes dark, providing a video quality on par with its daylight settings.

Its ability to see in the dark as well as the integrated motion detection functionality, turn this camera into the ideal device for remote video surveillance night and day; even when there is no light.

Using the web browser of any PC or notebook connected to the Internet (or Intranet), the NetCamera NV provides the user with a highly intuitive interface to manage and control it remotely, making it the ideal tool for remote monitoring and video surveillance.

1.2 System Requirements

Before installing the device, your PC should meet the following:



- Local Area Network: 10Base-T Ethernet or 100Base TX Fast Ethernet
- CPU: Intel Celeron 1.5GHz or above (Intel Pentium 4 is preferred)
- Memory Size: 128 MB (256 MB recommended)
- VGA card resolution: 800x600 or above
- Internet Explorer 5.0 or above (ActiveX)

1.3 Package Contents

Unpack the package and check all the items carefully. If any item contained is damaged or missing, please contact your local dealer as soon as possible. Also, keep the box and packing materials in case you need to ship the unit in the future. The package should contain the following items:

- One IP Security Wireless Night Vision Camera
- One Quick Installation Guide
- One Installation CD Rom with Manuals and Utility
- One Metal Clip (wall mounting).
- One DC Power Adapter
- One RJ-45 Ethernet Cable

If any of the above items are missing, please contact your reseller.

Chapter 2

Using NetCamera NV

2.1 Cautions for NetCamera NV

Read this section to learn how to set up your IP camera and use its basic functions.



Do not place the NetCamera NV under high humidity and high temperature. It can damage the device.

Do not use the same power source for NetCamera NV with other equipment.

Do not open or repair the case yourself.

If the NetCamera NV is too hot, turn off the power immediately and have a qualified serviceman repair it.



Ensure the camera is fixed securely otherwise it may fall and cause injury.

The camera is not waterproof and should not be mounted outside or in a position where it could become wet.

Place the NetCamera NV on a stable surface.

Only use the power adapter that comes with the package.

Do NOT upgrade firmware on any Atlantis Land product over a wireless connection. Failure of the device may result. Use only hard-wired network connections.

2.2 The Front LEDs

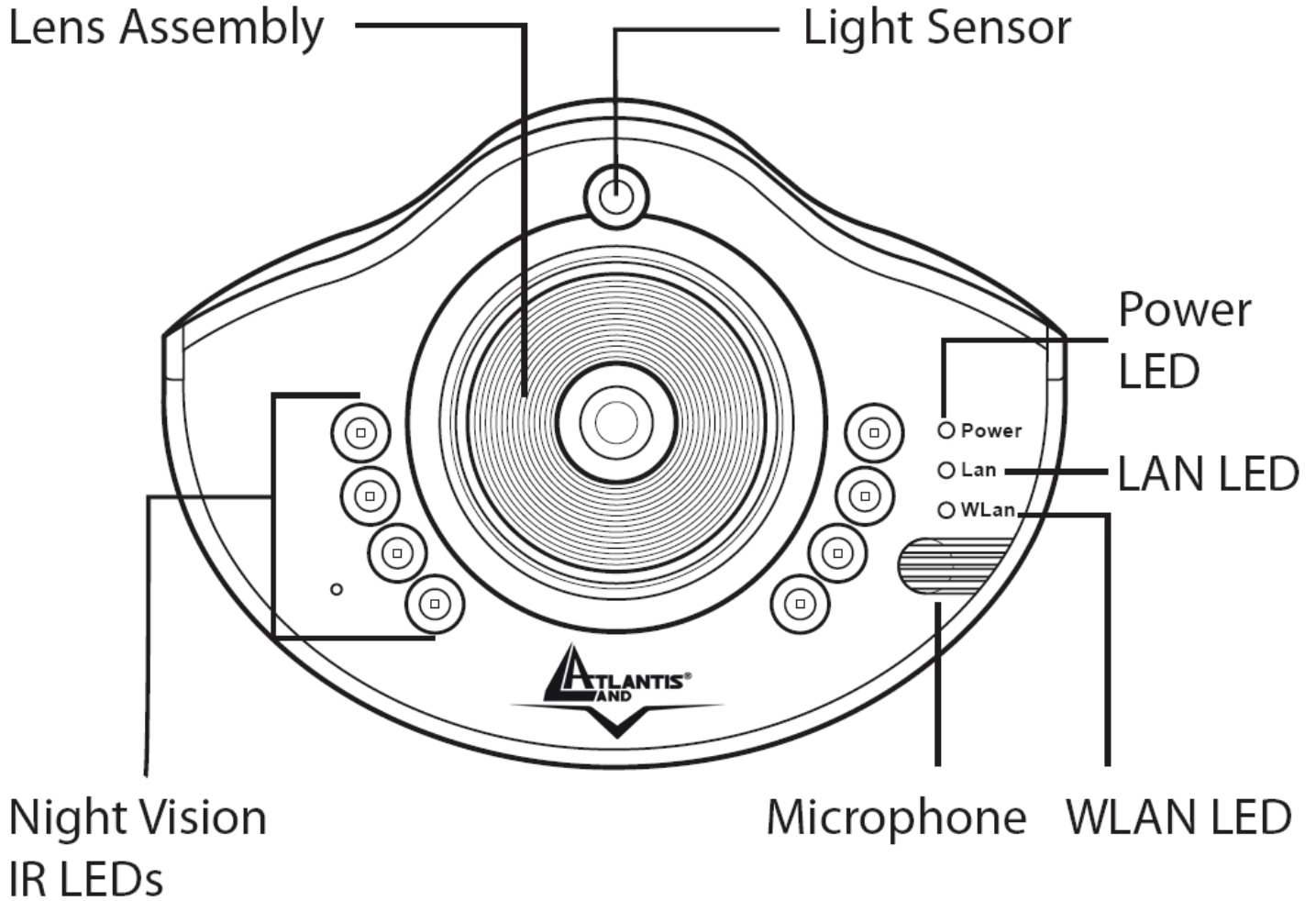

| LED | Meaning |
|-------|---|
| Power | Lights when power ON |
| Lan | Network activity indicator Flashes when sending/receiving data |



| | |
|---------------------|---|
| Night Vision | Furthermore, thanks its 8 integrated Infrared sensors, the NetCamera NV's automatic Day/Night functionality will change to Infrared mode as it becomes dark |
| Light Sensor | Light Sensor (Don't cover this Led) |
| Microphone | Microphone for environmental sound recording |

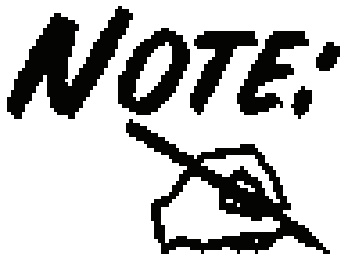

Use of audio or video equipment for recording the image or voice of a person without their knowledge and consent is prohibited in certain states or jurisdictions. Nothing herein represents a warranty or representation that the Atlantis product provided herein is suitable for the end-user's intended use under the applicable laws of his or her state. Atlantis disclaims any liability whatsoever for any end-user use of the Atlantis product, which fails to comply with applicable state, local, or federal laws.

2.3 The Rear Ports

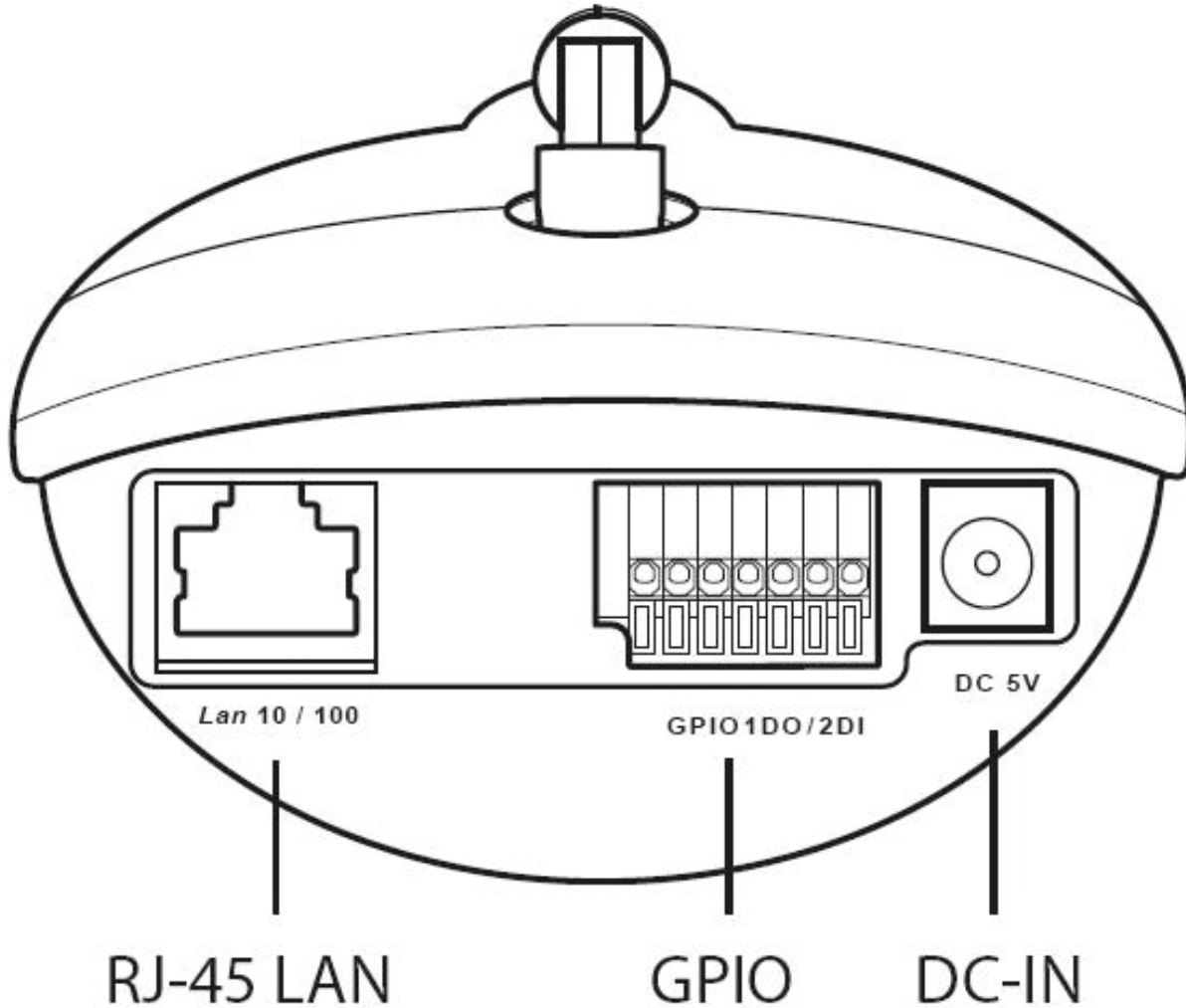

| Port | Meaning |
|------------------------|--|
| Network Cable | Ethernet port with 10/100Mbps Fast Ethernet connections, connect this port to switch/hub |
| GPIO Connectors | Its back panel contains 3 pairs of connectors (2 x DI input and 1 x DO output) |



| | |
|--------------|--|
| DC-IN | Connect the Power Adapter DC plug to the AP's power jack |
|--------------|--|

Please check the attached picture in order to obtain more info about GPIO port.

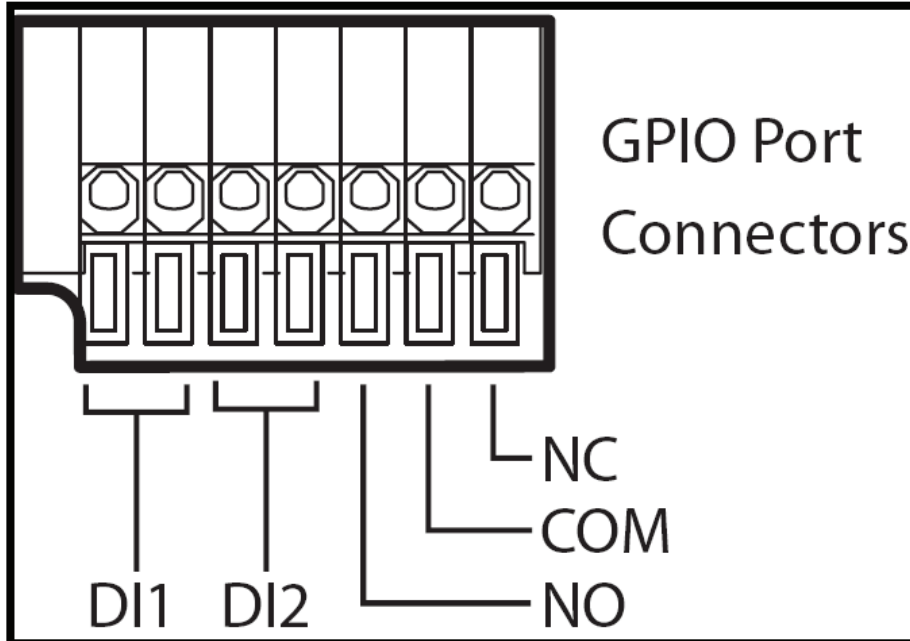

2.4 Assembling the Stand and Connecting to a Network

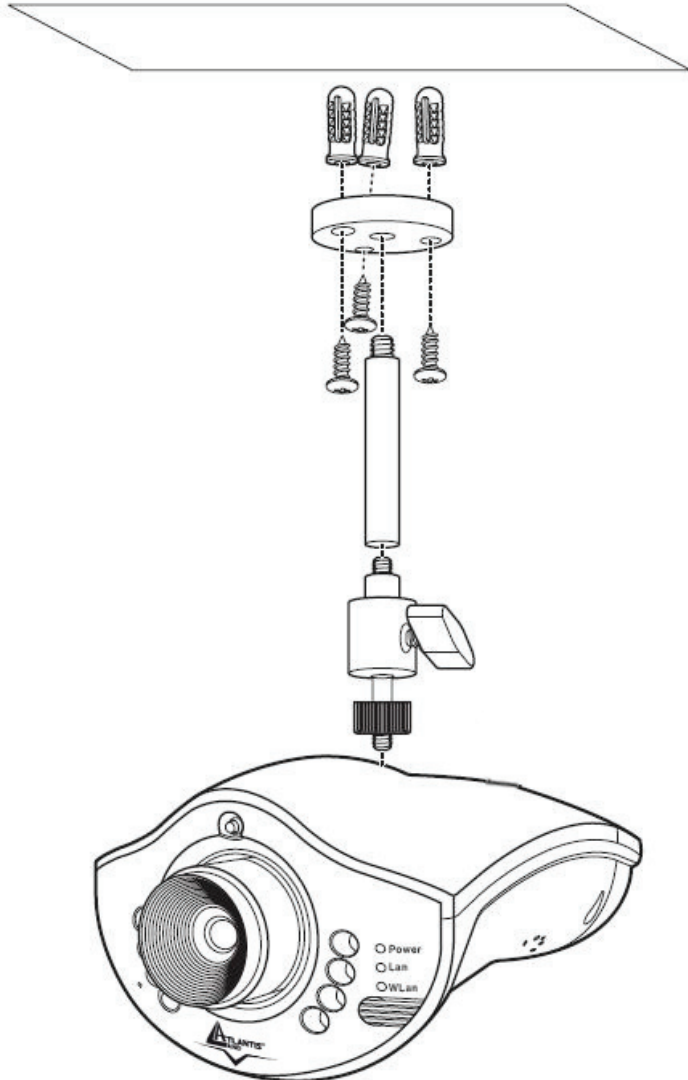

NOTE:

Ensure the camera is fixed securely otherwise it may fall and cause injury.

The camera is not waterproof and should not be mounted outside or in a position where it could become wet.

Connect the power adapter to the DC-IN socket on the camera as shown then check Power Led.

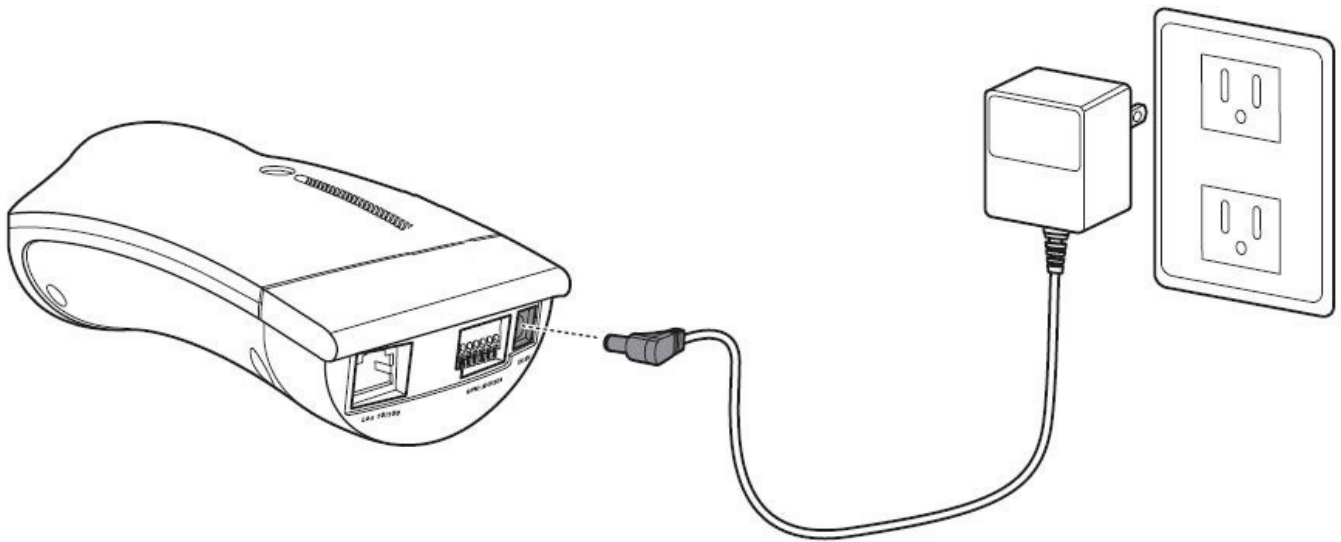

The IP camera can be connected to an Ethernet network using the RJ-45 port as shown. Connect the camera to an Ethernet hub or switch using a standard cable. You can also connect the camera directly to a computer using the supplied cable.

NOTE:

Use only the power adapter with the camera. Using another adapter, not recommended by the manufacturer, may damage the camera and invalidate the warranty.



Chapter 3

Configuration

The NetCamera NV can be configured with your Web browser. The web browser is included as a standard application in the following operation systems, UNIX, Linux, Mac OS, Windows 95/98/NT/2000/Me, and etc. The product provides a very easy and user-friendly interface for configuration.

3.1 Before Configuration

This section describes the configuration required by LAN-attached PCs that communicate with the NetCamera NV, either to configure the device or for network access. These PCs must have an Ethernet interface installed properly, be connected to the Router either directly or through an external repeater hub, and have a fixed IP address that must be in the same subnet of the NetCamera NV. The default IP address of the NetCamera NV is 192.168.1.1 and subnet mask is 255.255.255.0.

Please follow the steps below for PC's network environment installation. First of all, please check your PC's network components. The TCP/IP protocol stack and Ethernet network adapter must be installed. If not, please refer to MS Windows related manuals.

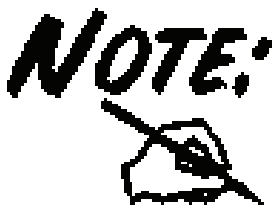

Any TCP/IP capable workstation can be used to communicate with or through the NetCamera NV. To configure other types of workstations, please consult the manufacturer's documentation.



3.1.1 Windows 95/98/ME

1. Go to **Start / Settings / Control Panel**. In the Control Panel, double-click on **Network** and choose the **Configuration** tab.
2. Select **TCP / IP -> NE2000 Compatible**, or the name of any Network Interface Card (NIC) in your PC.
3. Click **Properties**.
4. Select the **IP Address** tab. In this page, click the **Specify an IP address** radio button (EG **IP=192.168.1.2** and subnet Mask=255.255.255.0).

3.1.2 Windows NT4.0

1. Go to **Start / Settings / Control Panel**. In the Control Panel, double-click on **Network** and choose the **Protocols** tab.
2. Select **TCP/IP Protocol** and click **Properties**.
3. Select the **IP Address** tab. In this page, click the **Specify an IP address** radio button (EG **IP=192.168.1.2** and subnet Mask=255.255.255.0).

3.1.3 Windows 2000

1. Go to **Start / Settings / Control Panel**. In the Control Panel, double-click on **Network and Dial-up Connections**.
2. Double-click **LAN Area Connection**.
3. In the **LAN Area Connection Status** window, click **Properties**.
4. Select **Internet Protocol (TCP/IP)** and click **Properties**.
5. Select **Use the Following IP Address** (EG **IP=192.168.1.2** and subnet Mask=255.255.255.0).
6. Click **“OK”** to finish the configuration.



3.1.4 Windows XP

1. Go to **Start / Control Panel** (in Classic View). In the Control Panel, double-click on **Network Connections**.
2. Double-click **Local Area Connection**
3. In the LAN Area Connection Status window, click **Properties**.
4. Select **Internet Protocol (TCP/IP)** and click **Properties**.
5. Select the **Use the following IP address** radio buttons (**EG IP=192.168.1.2** and subnet Mask=255.255.255.0).
6. Click **“OK”** to finish the configuration.

3.2 Default Settings

Before you configure this NetCamera NV, you need to know the following default settings:

- **Password: admin**
- **Username: atlantis**
- **Indirizzo IP: 192.168.1.1**
- **Subnet Mask(255.255.255.0)**

3.3 Browser configuration

Open the web browser, enter the local port IP address of this NetCamera NV, which default at **192.168.1.1**, and click “Go” to get the login page.

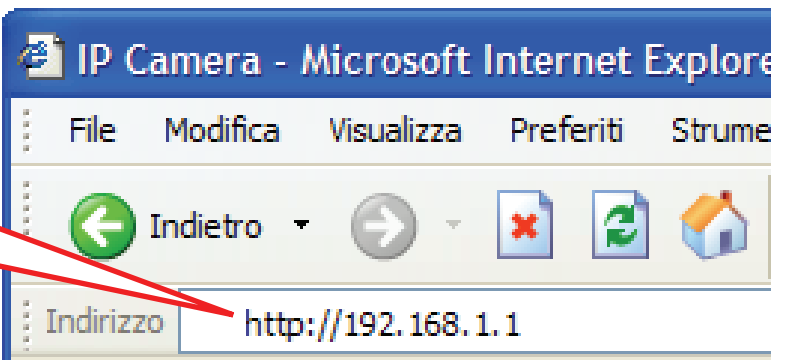

Enter the default IP Address in the Address bar



Enter the default username and password

At the configuration homepage, the left navigation pane where bookmarks are provided links you directly to the desired setup page, including:



NOTE!

Please refer to the appendix on how to install ActiveX.

- At the top click **This site might require the following ActiveX Control: 'ATL3.0:VCView'** from 'Atlantis Land SpA '. Click here to install....
- Click **Install ActiveX Control....**
- In the *Security Warning* window click **Install**.
- The live video will now be streamed.

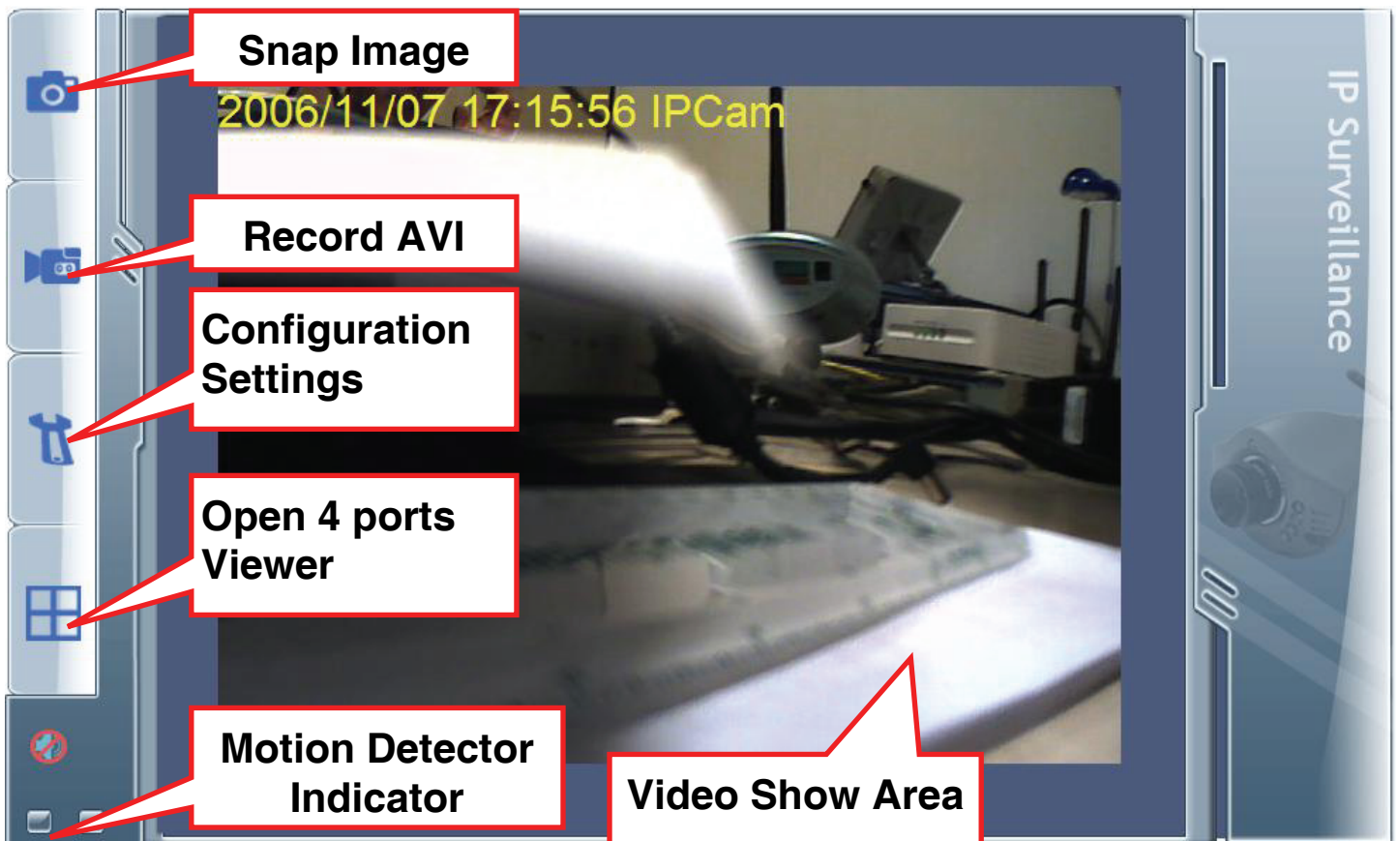

Use the menu bar on the left side of the screen to perform actions and enter the sub-menus:

- **Snap Image:** Click to save the current image.
- **Record AVI:** Click to record an AVI video clip.
- **Configuration Settings:** Click to enter the settings sub-menus.
- **Open 4 ports View:** Click to view the output of up to four other IP cameras on the network.



For more detailed instructions on configuring and using the NetCamera NV, please refer to the online manual.



The computer's IP address must correspond with the camera's IP address in the same segment for the two devices to communicate (E.G. IP=192.168.1.2 and Subnet Mask=255.255.255.0).

Chapter 4

Advanced Configuration

Read this chapter to learn how to operate the IP camera and take advantage of the advanced features such as alerting, and ftp transfers.

Open the web browser, enter the local port IP address of this NetCamera NV, which default at **http://192.168.1.1**, and click “Go” to get the login page.

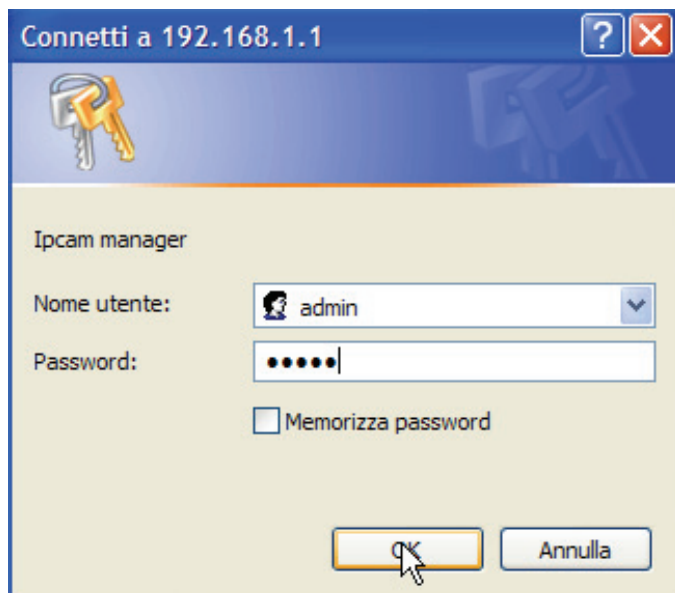

Enter your User Name and password. The default are **admin / atlantis**.



Please refer to the appendix on how to install ActiveX.

- At the top click **This site might require the following ActiveX Control: 'ATL3.0:VCView'** from 'Atlantis Land SpA'. **Click here to install....**
- Click **Install ActiveX Control....**
- In the *Security Warning* window click **Install**.
- The live video will now be streamed.



To access the settings menus, do the following:



Click the button on the menu sidebar. A login prompt appears:



The computer's IP address must correspond with the camera's IP address in the same segment for the two devices to communicate.

If you are denied to enter the Web Configuration Utility, the following warning message will appear on the screen. Please try to enter the correct username and password again, or contact your network administrator.



There are 3 sub menus in the menu sidebar: Home, Basic Setting and Advanced Setting.

The screenshot shows the web interface for the NetCamera NV. On the left is a sidebar menu with icons for Home, Basic, and Advanced. The main content area is titled 'System' and contains a list of sub-menus: System, Network, User, Video, and Video Player. The 'Basic Settings' page is displayed, showing the camera name 'IPCam-5C24' and a 'Save' button. Below this, network settings are listed: LAN IP Address (192.168.1.186), LAN Netmask Address (255.255.255.0), LAN Gateway Address (192.168.1.6), and DHCP State (Disabled). A 'Wireless Status' section shows the connection is 'DOWN', with channel 1, 0% signal level, and a TX rate of 54Mbps.

| Home Page | |
|-------------|--|
| Camera Name | IPCam-5C24 <input type="button" value="Save"/> |

| Basic Settings | |
|---------------------|---------------|
| LAN IP Address | 192.168.1.186 |
| LAN Netmask Address | 255.255.255.0 |
| LAN Gateway Address | 192.168.1.6 |
| DHCP State | Disabled |

| Advanced Settings | |
|-------------------|--------|
| Wireless Status | |
| Connection | DOWN |
| Channel | 1 |
| Signal Level | 0% |
| TX Rate | 54Mbps |



4.1 Basic Settings

Read this section to learn about all the settings and options under the Basic Setting sub menu. There are five main screens, accessed via the tabs at the top of the screen:

- System
- Network
- User
- Video
- Monitor

4.1.1 System

The System submenu allows you to configure all system-related settings. There are four main screens, accessed via the tabs at the top of the screen:

- Configuration
- Firmware
- Other



Configuration

Click the **Configuration** tab to access the configuration status screen:

Here is displayed all system information, including firmware version and device name, and is where you can configure date and time options.

Configuration | **Firmware** | **Others**

Server Info

Information

Firmware Version: C61200-WX-2.00.00.60630-ZZ

Date & Time

Configuration

Sync with Time Server 12/14/2006 11:32:54

Time Zone: (GMT+01:00)Amsterdam,Berlin, Bern, Rome, Stockholm, Vienna ▾

NTP Server: 192.5.41.40 ▾

Other Server: 0.0.0.0

Day Light Saving: Enable

Sync with PC time 12/14/2006 11:32:50

Choose to either Sync with Time Server or Sync with PC Time.

Check the radio button for the setting you wish to use. If you select **Sync with Time Server**, choose your time zone, enter NTP server details, along with another server if necessary. You can also enable daylight saving time by checking the Daylight Saving Time checkbox.

If you select **Sync with PC Time**, the current time displayed by your PC is shown.

Click the **Submit** button to confirm your settings.



If You meet problems, please follow these instructions:

NTP Server=pool.ntp.org or 128.138.140.44

NTP Server=192.5.41.40

Click the **Submit** button to save your settings and to update the system date and time.



Firmware

Click the **Firmware** tab to access the firmware upgrade screen:
Here you can upgrade the system firmware version.

Configuration | **Firmware** | **Others**

Firmware Upgrade

Notice & Recommendation

Updating the firmware only if you have problems and you are sure that the new firmware will solve your problems.

Caution! Careless updating or interruption during the process may cause the device malfunction! Further more, for too many unpredictable conditions may occur in Internet, it is strongly recommended to do this process in Intranet.

P.S. Please **reboot** the device before you start to upgrade the firmware.

The whole process may take a few minutes depending on the network condition. Please be patient to wait

Firmware:

Click the **Sfoggia(Browse)** button and locate the folder where the firmware update is stored. Click the **Upgrade** button to upgrade the firmware.



Do NOT upgrade firmware on any Atlantis Land product over a wireless connection. Failure of the device may result. Use only hard-wired network connections.

After upgrading you must reset the router to factory default settings, then manually re-enter your settings.



Please pay attention. In case electrical shutdown, during this procedure, this product could be not usable.

When uploading software to theNetCamera NV, it is important not to interrupt the Web browser by closing the window or loading a new page. If the browser is interrupted, it may corrupt the software.



Others

Here you can reset and restore original camera settings.

[Configuration](#) | [Firmware](#) | [Others](#)

Others

Restore Factory Default

This allows you to restore factory default settings. Please make sure if you really want to do it.

[Restore Factory Default](#)

Remote Reboot

This allows you to reboot the device remotely.

[Remote Reboot](#)

Click the **Restore to Factory Default** button to reset all parameters to original factory settings.

Click the **Remote Reboot** button to restart the camera.



4.1.2 Network

The **Network** submenu allows you to configure all system-related settings. There are 3 main screens, accessed via the tabs at the top of the screen:

- Ethenet
- PPPoE
- Dynamic DNS



Ethernet

Click the **Ethernet** tab to access the ethernet settings screen:

| | | |
|---------------------------------------|--|----------------------------|
| Ethernet | PPPoE | DDNS |
| <h3>IP Setting</h3> | | |
| Ethernet | | |
| IP Assignment | <input checked="" type="radio"/> Static | <input type="radio"/> DHCP |
| IP Address | <input type="text" value="192.168.1.1"/> | |
| Subnet Mask | <input type="text" value="255.255.255.0"/> | |
| Default Gateway | <input type="text" value="192.168.1.6"/> | |
| MAC Address | <input type="text" value="00:14:29:00:3B:D5"/> | |
| DNS & HTTP Port | | |
| DNS 1 | <input type="text" value="0.0.0.0"/> | |
| DNS 2 | <input type="text" value="0.0.0.0"/> | |
| Port | <input type="text" value="80"/> | |
| <input type="button" value="Submit"/> | | |

Here you can configure all settings related to your Ethernet and DNS & HTTP port setup.

Under **IP Setting** and **DNS Configuration**, either enter the settings manually or select the **DHCP** button to obtain the addresses via DHCP.

Click the **Submit** button to save your settings.

HTTP Port: This is the port number the router's embedded web server (for web-based configuration) will use. The default value is the standard HTTP port, 80. Users may specify an alternative if, for example, they are running a web server on a PC within their LAN.

For Example: User A changes HTTP port number to 8081. The NetCamera NV will only allow User A access typing: <http://192.168.1.1:8081> in their web browser.



PPPoE

Click the **PPPoE** tab to access the PPPoE settings screen:

| | | |
|---------------------------------------|--------------------------------------|-------------|
| Ethernet | PPPoE | DDNS |
| <h2>PPPoE</h2> | | |
| Configuration | | |
| PPPoE: | <input type="checkbox"/> Enable | |
| User Name: | <input type="text"/> | |
| Password: | <input type="password"/> | |
| MTU (1360 ~ 1492): | <input type="text" value="1492"/> | |
| <input type="button" value="Submit"/> | | |
| Status | | |
| IP Address: | <input type="text" value="0.0.0.0"/> | |
| Subnet Mask: | <input type="text" value="0.0.0.0"/> | |
| Default Gateway: | <input type="text" value="0.0.0.0"/> | |
| Primary DNS Server: | <input type="text" value="0.0.0.0"/> | |
| Secondary DNS Server: | <input type="text" value="0.0.0.0"/> | |

Here you can configure all PPPoE connection settings. If you connect to your network via PPPoE, check the **Enable PPPoE** checkbox and enter your User Name, password and MTU. Click the **Submit** button to save all changes. The system will begin to connect via PPPoE. Status details are displayed under Status.



Dynamic DNS client can works correctly only if PPPoE is activated.





DDNS

Click the **DDNS** tab to access the DDNS settings screen:

Here you can configure all DDNS connection settings.

Go to www.dyndns.org to register a domain name and obtain a username and password. Enter this domain name, username, and password in the DDNS settings screen.

Dynamic DNS

Configuration

Dynamic DNS Enable

Choose Server **DynDNS** (http://www.dyndns.com)

DNS Domain

User Name

Password:

Status

Submit

Click the **Submit** button to save your settings.



When the IP address of the camera changes, it will update its new address to DDNS automatically and the camera can be contacted using a domain name instead of an IP address. DNS status is displayed under **Status**.



Dynamic DNS client can works correctly only if PPPoE is activated.



4.1.3 User

The User submenu enables you to set up users and administrators for the system.

The screenshot shows three sections of the user management interface:

- User Authorization:** Contains a checkbox labeled "Enable User Check" which is currently unchecked. To its right is a "Submit" button.
- Add/Modify User:** Contains a dropdown menu for "User Group" with "User" selected. Below it are three text input fields for "User Name:", "Password:", and "Confirm Password:". A "Submit" button is located at the bottom of this section.
- Delete User:** Contains a dropdown menu for "Admin Group" with "admin" selected and a "Submit" button. Below it is another dropdown menu for "User Group" and a second "Submit" button.

Under **User Authorization**, check **Enable User Check** if you wish to run a login process every time you access the system. Click the **Submit** button to confirm this setting.

Under **Add/ Modify User**, enter a new username and password in the required fields to create new user names. Assign each user to either the admin or user groups. Click the **submit** button to confirm the new setting.

Under **Delete User**, select a username from either an admin or user group you want to delete. Click the **Submit** button to delete the user.

4.1.4 Video

The Video submenu enables you to configure all video settings:

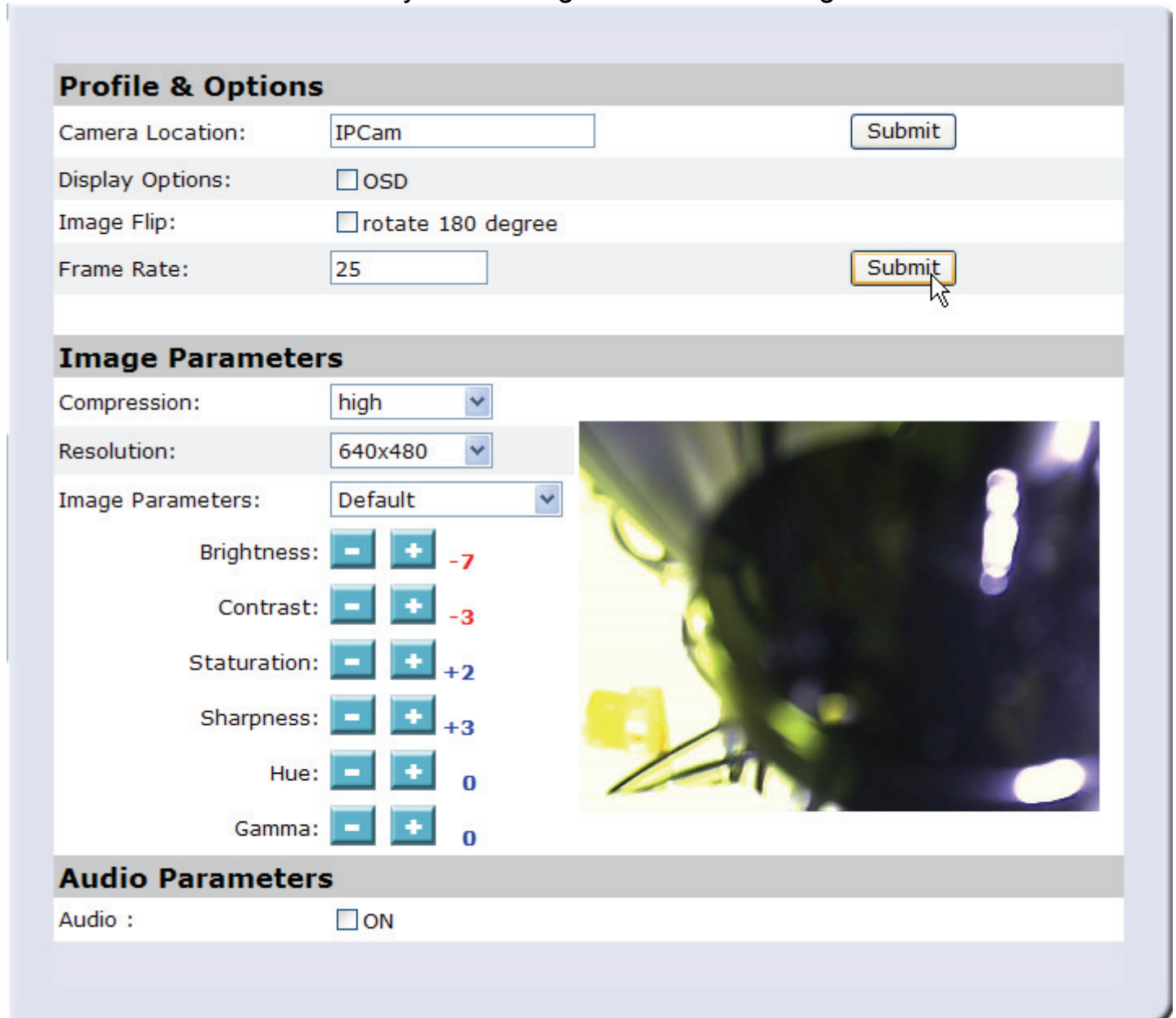

The screenshot displays the configuration interface for the NetCamera NV, divided into three main sections: Profile & Options, Image Parameters, and Audio Parameters.

- Profile & Options:** This section contains four rows of settings. The first row has 'Camera Location' set to 'IPCam' with a 'Submit' button. The second row has 'Display Options' with an unchecked checkbox for 'OSD'. The third row has 'Image Flip' with an unchecked checkbox for 'rotate 180 degree'. The fourth row has 'Frame Rate' set to '25' with a 'Submit' button.
- Image Parameters:** This section includes a preview window on the right showing a close-up of a green insect. To the left of the preview are several controls: 'Compression' set to 'high', 'Resolution' set to '640x480', and 'Image Parameters' set to 'Default'. Below these are sliders for 'Brightness' (-7), 'Contrast' (-3), 'Saturation' (+2), 'Sharpness' (+3), 'Hue' (0), and 'Gamma' (0).
- Audio Parameters:** This section is at the bottom and contains a single setting: 'Audio' with an unchecked checkbox for 'ON'.

Under **Profile & Options**, you can alter various options:

- **Camera Location:** Enter the camera location. Click the **Submit** button to confirm this setting.
- **Display Options:** Check the checkbox to show the date, time, and camera location on the display screen.
- **Image Flip:** Check to rotate the display image 180 degrees.



- **Frame Rate:** Enter the required frame rate. Click the **Submit** button to confirm this setting.

Under **Image Parameters**, you can alter image output options.

Select the image compression rate, and resolution you require from the dropdown boxes.

Make any adjustments for brightness, contrast, saturation, sharpness, hue and gamma of the image using the + or - buttons.

Under **Audio Parameters**, check the checkbox to turn audio on or off.



4.1.5 Monitor

The 4-port monitor setting screen appears:

| 4-Port Monitor Setting | | | | |
|---------------------------------------|--|----------------------|---------------------------------|---------------------------------|
| Configuration | | | | |
| Camera1 IP: | <input type="text" value="192.168.1.184"/> | : | <input type="text" value="80"/> | <input type="checkbox"/> Enable |
| <input type="button" value="Submit"/> | Login/Password: | <input type="text"/> | <input type="text"/> | |
| Camera2 IP: | <input type="text" value="0.0.0.0"/> | : | <input type="text" value="80"/> | <input type="checkbox"/> Enable |
| <input type="button" value="Submit"/> | Login/Password: | <input type="text"/> | <input type="text"/> | |
| Camera3 IP: | <input type="text" value="0.0.0.0"/> | : | <input type="text" value="80"/> | <input type="checkbox"/> Enable |
| <input type="button" value="Submit"/> | Login/Password: | <input type="text"/> | <input type="text"/> | |
| Camera4 IP: | <input type="text" value="0.0.0.0"/> | : | <input type="text" value="80"/> | <input type="checkbox"/> Enable |
| <input type="button" value="Submit"/> | Login/Password: | <input type="text"/> | <input type="text"/> | |

Enter the IP address, port, login and password of each camera you wish to view and check the **Enable** checkbox.

Click the **Submit** button to confirm your settings.

Click the **Home** tab on the menu sidebar to return to the main screen, then click the **4-Port Viewer** to switch to 4-port viewing mode.

4.2 Advanced

The camera will function fine after the **Basic** configuration, however, you may wish to explore more advanced options. This section explains each parameter and setting procedures for advanced configuration of the camera. Move your mouse onto the **Advanced** button, and it will automatically pop up a submenu bar as below.

4.2.1 FTP

The **FTP** submenu enables you to configure all FTP (File Transfer Protocol) settings:

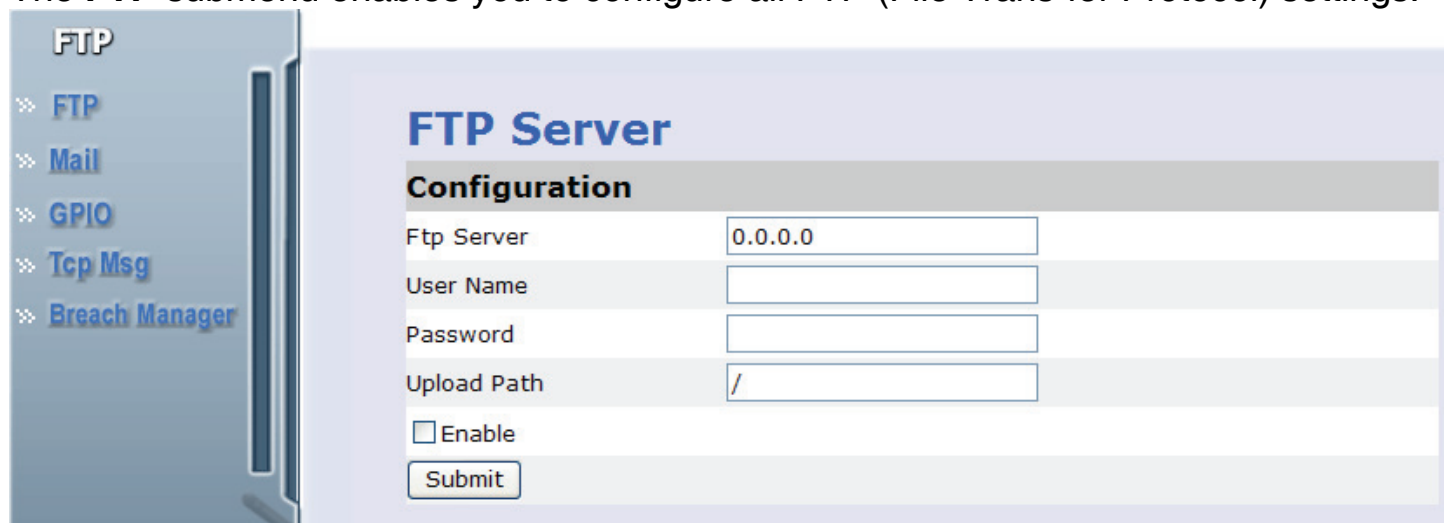

The screenshot shows a web interface for configuring the FTP server. On the left is a vertical menu with the following items: FTP, FTP, Mail, GPIO, Tcp Msg, and Breach Manager. The main content area is titled "FTP Server Configuration" and contains the following fields:

| FTP Server Configuration | |
|---------------------------------------|--------------------------------------|
| Ftp Server | <input type="text" value="0.0.0.0"/> |
| User Name | <input type="text"/> |
| Password | <input type="text"/> |
| Upload Path | <input type="text" value="/"/> |
| <input type="checkbox"/> Enable | |
| <input type="button" value="Submit"/> | |

When FTP alerting is enabled, the camera sends a still image to the ftp server every time the alert is triggered (see "**Breach Manager**" for details on how to activate this option).

Enter your FTP address, along with username, password and folder to which the images will be uploaded.

Click the **Submit** button to save all changes.



Breach Manager

Configuration

Breach ID

Duration sec (Max to 60 sec)

Trigger

Camera Location

Action

FTP MAIL

DO DO Last sec

MSG

Enable

Status

Motion FTP.. Enable



All upload files on FTP are in .jpg format.



4.2.2 Mail

The **Mail** submenu enables you to configure all mail server set-tings:

Mail Server Configuration

| | |
|---------------|--------------------------------------|
| Mail Server | <input type="text" value="0.0.0.0"/> |
| User Name | <input type="text"/> |
| Password | <input type="text"/> |
| Mail Sender | <input type="text"/> |
| Mail Receiver | <input type="text"/> |
| Mail Subject | <input type="text"/> |

Enable

When mail alerting is enabled, the camera sends a still image to a specified email address every time the alert is triggered (see “**Breach Manager**” for details on how to activate this option).

Enter your mail server address, mail sender address, and mail receiver address (username and password for authentication).

Click the **Submit** button to save all changes.

Breach Manager Configuration

| | | | |
|-----------------|---|---|--|
| Breach ID | <input type="text" value="0"/> | Duration | <input type="text" value="3"/> sec (Max to 60 sec) |
| Trigger | <input type="text" value="Motion"/> | | |
| Camera Location | <input type="text" value="IPCam"/> | | |
| Action | <input type="checkbox"/> FTP | <input checked="" type="checkbox"/> MAIL | |
| | <input type="checkbox"/> DO <input type="text" value="None"/> <input type="text" value="ON"/> | <input type="checkbox"/> DO Last <input type="text" value="0"/> sec | |
| | <input type="checkbox"/> MSG | | |

Enable

Status

| | | |
|--------|-------|--------|
| Motion | FTP.. | Enable |
|--------|-------|--------|



NetCamera NV

4.2.3 GPIO

The **GPIO** submenu enables you to configure all DI sensor and DO settings:

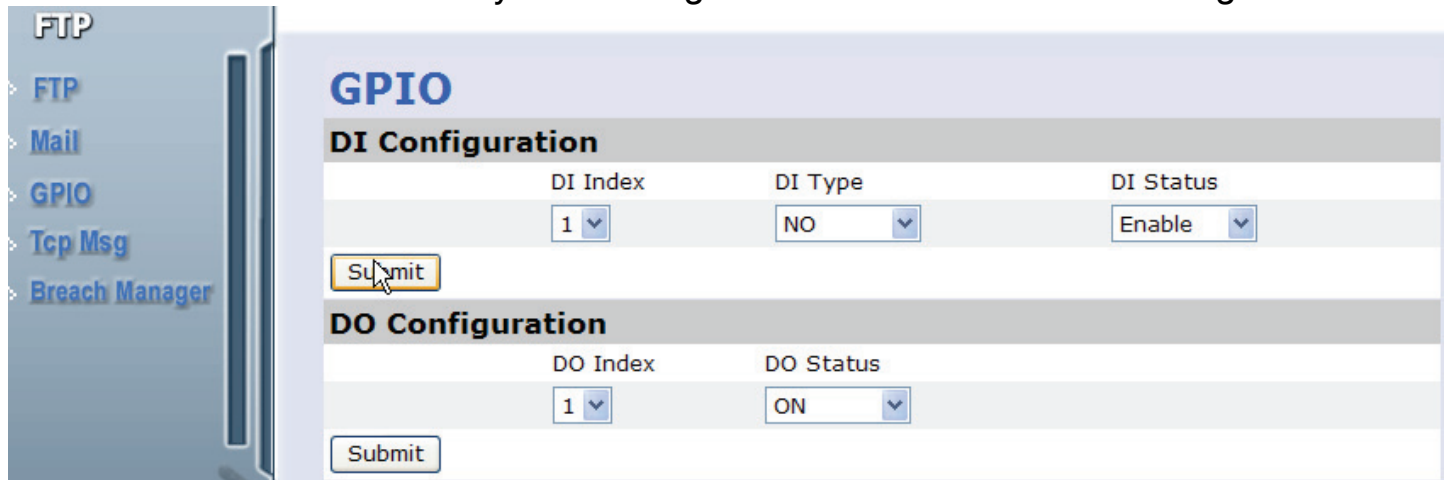

| DI Index | DI Type | DI Status |
|----------|---------|-----------|
| 1 | NO | Enable |

| DO Index | DO Status |
|----------|-----------|
| 1 | ON |

External DI sensors can be attached via the GPIO port at the rear of the camera. The external sensor can be normally open, or normally closed. A normally open sensor is like an open switch that closes when triggered. A normally closed sensor is like a closed switch that opens when triggered. This must be set correctly for an external sensor to function properly. You can connect up to two DI sensors to the camera.

An external DO alarm can also be attached to the camera via the GPIO port at the rear of the camera.

Under **DI Configuration**, select **Normal Open** or **Normal Close** for each DI1 and DI2. Click the **Submit** button to confirm all settings.

Under **DO Configuration**, select **Normal Open** or **Normal Close** for the DO alarm. Click the **Submit** button to confirm all settings.



4.2.4 TCP Message

The **Tcp Message** submenu enables you to configure all tcp message settings:

Tcp Msg

- ❖ FTP
- ❖ Mail
- ❖ GPIO
- ❖ **Tcp Msg**
- ❖ Breach Manager

TCP Message

Configuration

| | |
|---------------------------------|--------------------------------------|
| Server IP | <input type="text" value="0.0.0.0"/> |
| Port | <input type="text" value="50000"/> |
| Subject | <input type="text"/> |
| <input type="checkbox"/> Enable | |

Enter the Server IP address, port and message subject. Check the **Enable** checkbox and click the **Submit** button to confirm all settings.

4.2.5 Breach Manager

The **Breach Manager** submenu enables you to configure all breach alert and motion detection settings:

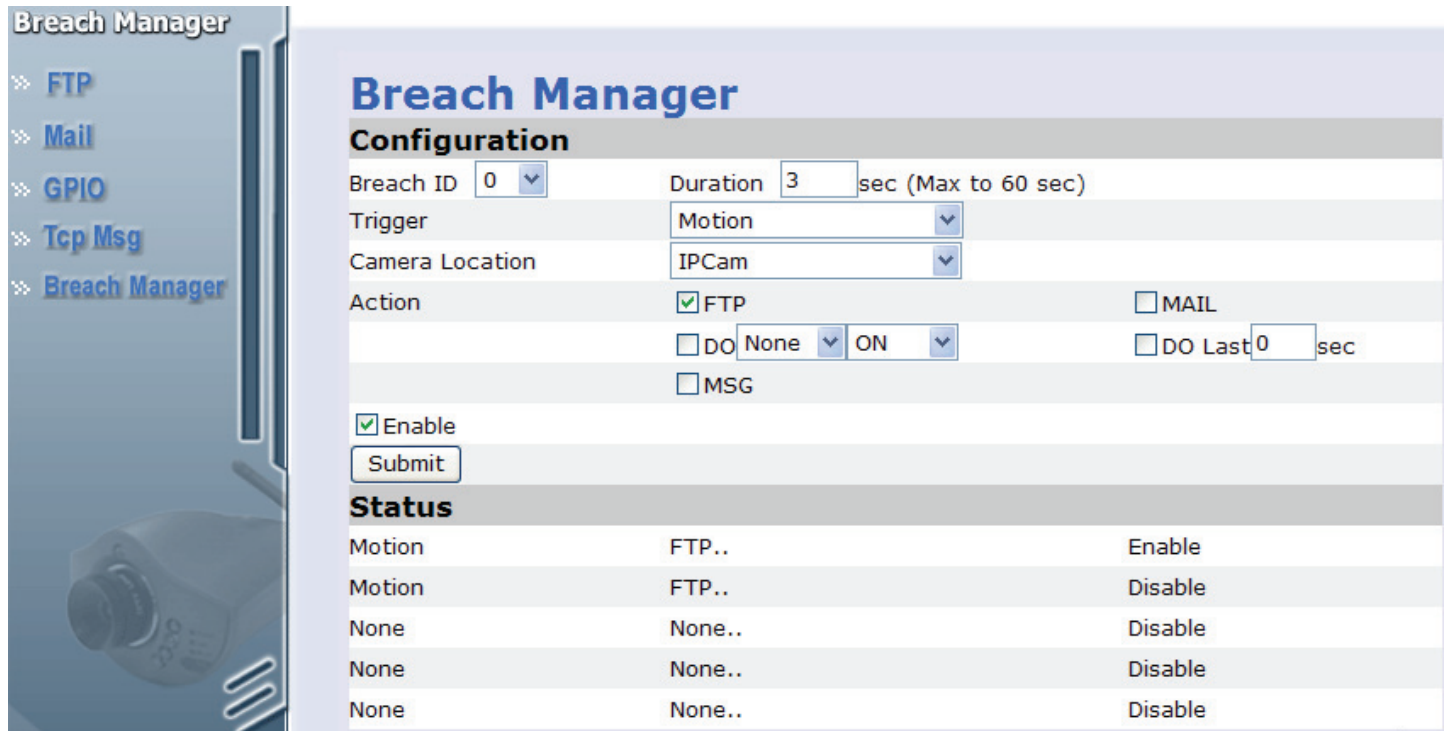

The screenshot shows the 'Breach Manager' configuration page. On the left is a sidebar with navigation links: FTP, Mail, GPIO, Tcp Msg, and Breach Manager (highlighted). The main content area is titled 'Breach Manager Configuration' and includes the following fields:

- Breach ID:** 0 (dropdown)
- Duration:** 3 sec (Max to 60 sec)
- Trigger:** Motion (dropdown)
- Camera Location:** IPCam (dropdown)
- Action:**
 - FTP
 - MAIL
 - DO: None (dropdown), ON (dropdown)
 - DO Last: 0 sec
 - MSG
- Enable
-

Below the configuration is a 'Status' table:

| Status | | |
|--------|--------|---------|
| Motion | FTP.. | Enable |
| Motion | FTP.. | Disable |
| None | None.. | Disable |
| None | None.. | Disable |
| None | None.. | Disable |

You can configure the system to capture images when either the motion sensors, DI1 or DI2 sensors are activated.

To set a breach alert, do the following:

- Select a breach ID from the dropdown menu and enter the duration of the alert. You can configure up to five separate alerts at any one time.
- Select the alert trigger (DI1, DI2, MOTION, None) device and camera location from the dropdown menus.
- Check the radio buttons to select whether to be alerted by ftp upload, email, tcp message or external DO alarm. If external DO alarm is selected, choose the alarm type from the dropdown menu, select ON to activate the alarm, and enter the alarm length time in the DO Last field.
- Check the **Enable** checkbox and click the **Submit** button to confirm all settings.



The **Status** window lists all configured alert details; the first column lists the alarm trigger type, the second lists the action type, and the third displays whether the alert is enabled or disabled.



Chapter 5

Support

5.1 Support

If you have any problems with the IP Night Vision Camera, please consult this manual. If you have any other questions you can contact the Atlantis Land company directly at the following address:

Atlantis Land SpA
Viale De Gasperi, 122
20017 Mazzo di Rho(MI)
Tel: +39. 02.93906085, +39. 02.93907634(help desk)
Fax: +39. 02.93906161

Email: info@atlantis-land.com or tecnici@atlantis-land.com
WWW: <http://www.atlantis-land.com>



APPENDIX A: Frequently Asked Questions

A.1 Using LEDs to Diagnose Problems

The LEDs are useful aides for finding possible problem causes.

A.1.1 LED Power

The PWR LED on the front panel does not light up.

| Steps | CORRECTIVE ACTION |
|-------|--|
| 1 | Make sure that the NetCamera NV's power adaptor is connected to the Access Point and plugged in to an appropriate power source. Use only the supplied power adaptor. |
| 2 | Check that the NetCamera NV and the power source are both turned on and the NetCamera NV is receiving sufficient power. |
| 3 | If the error persists, you may have a hardware problem. In this case, you should contact Atlantis Land SpA. |

A.1.2 LED LAN

The LAN LED on the front panel does not light up.

| Steps | CORRECTIVE ACTION |
|-------|--|
| 1 | Check the Ethernet cable connections between the NetCamera NV and the computer or hub. |
| 2 | Check for faulty Ethernet cables. |
| 3 | Make sure your computer's Ethernet card is working properly. |
| 4 | If these steps fail to correct the problem, contact Atlantis Land SpA for assistance. |



A.2 WEB

I cannot access the web configurator.

| Steps | CORRECTIVE ACTION |
|-------|---|
| 1 | Make sure you are using the correct IP address of the NetCamera NV. Check the IP address of the NetCamera NV (192.168.1.1). |

The web configurator does not display properly.

| Steps | CORRECTIVE ACTION |
|-------|---|
| 1 | Make sure you are using Internet Explorer 5.0 and later versions. |
| 2 | Make sure you are using Internet Explorer 5.0 and ActiveX is installed. |
| 3 | Delete the temporary web files and log in again. In Internet Explorer, click Tools, Internet Options and then click the Delete Files ... button. When a Delete Files window displays, select Delete all offline content and click OK. (Steps may vary depending on the version of your Internet browser.) |

A.3 Login

If you forget the password to log in

| Steps | CORRECTIVE ACTION |
|-------|---|
| 1 | The Reset function is to reset the setting back to factory default setting, once you press the "RESET" button within 10 seconds. |
| 2 | Before configuring this device , you need to know the following default settings: Password : admin IP Address : 192.168.1.1 Subnet Mask : 255.255.255.0 |



A.4 General Questions

| | |
|-----------------|---|
| Question | What is an IP Security Night Vision Camera? |
| Answer | The IP Security Night Vision Camera is a standalone system connecting directly to an Ethernet or Fast Ethernet network. It is different from the conventional PC Camera, the IP Security Night Vision Camera is an all-in-one system with built-in CPU and web-based solutions providing a low cost solution that can transmit high quality video images for monitoring. The IP Security Night Vision Camera can be managed remotely, accessed and controlled from any PC/Notebook over the Intranet or Internet via a web browser. |
| Question | What is the maximum number of users that can be allowed to access the IP Security Night Vision Camera simultaneously? |
| Answer | Maximum number of users that can log onto the IP Security Night Vision Camera at the same time is 20. Please keep in mind the overall performance of the transmission speed will slow down when many users are logged on. |
| Question | What algorithm is used to compress the digital image? |
| Answer | The camera utilizes the MJPEG image compression technology providing high quality images for users. |
| Question | Can the IP Security Night Vision Camera be used outdoors? |
| Answer | The IP Security Night Vision Camera is not weatherproof. It needs to be equipped with a weatherproof case to be used outdoors and it is not recommended. |



| | |
|-----------------|---|
| Question | What network cabling is required for the IP Security Night Vision Camera? |
| Answer | The IP Security Night Vision Camera uses Category 5 UTP cable allowing 10 Base-T and 100 Base-T networking. |

| | |
|-----------------|--|
| Question | Can the IP Security Night Vision Camera be setup as a PC-cam on the computer? |
| Answer | No, the IP Security Night Vision Camera is an IP Security Night Vision Camera used only on Ethernet and Fast Ethernet network. |

| | |
|-----------------|---|
| Question | Can the IP Security Night Vision Camera be connected on the network if it consists of only private IP addresses? |
| Answer | The IP Security Night Vision Camera can be connected to LAN with private IP addresses. |

| | |
|-----------------|---|
| Question | Can the IP Security Night Vision Camera be installed and work if a firewall exists on the network? |
| Answer | If a firewall exists on the network, port 80 is open for ordinary data communication. |



APPENDIX B: Trouble Shooting

This chapter covers potential problems and the corresponding remedies.

| | |
|-----------------|--|
| Question | I cannot access the IP Security Night Vision Camera from a web browser. |
| Answer | <p>The possible cause might be the IP Address for the IP Security Night Vision Camera is already being used by another device. To correct the possible problem, you need to first disconnect the IP Security Night Vision Camera from the network. Then run the PING utility.</p> <p>The PING command can determine whether a specific IP address is accessible by sending a packet to the specific address and waiting for a reply. It can also provide a very useful tool to confirm if the IP address conflicts with the camera over the network.</p> <p>Follow the step-by-step procedure below to utilize the PING command. However, you must disconnect the camera from the network first.</p> <p>Start a DOS window.</p> <p>Type ping 192.168.1.1, where 192.168.1.1 is the IP address of the camera.</p> <p>The succeeding replies as illustrated below will provide useful explanation to the cause of the problem with the camera IP address.</p> |

| | |
|-----------------|--|
| Question | I cannot access the IP Security Night Vision Camera from a web browser. |
| Answer | <p>Another possible reason is the IP Address is located on a different subnet. To fix the problem, run the PING utility. If the utility returns “no response” or similar, the finding is probably correct, then you should proceed as follows:-</p> <p>In Windows 95/98/2000 and Windows NT, double check the IP</p> |



Address of the IP Security Night Vision Camera is within the same subnet as your workstation.

Click “Start”, “Setting”, “Control Panel”, and the “Network” icon. Select TCP/IP from the “Network” dialog box and from the “TCP/IP Properties” dialog box click “Specify an IP address”. If the IP Security Night Vision Camera is situated on a different subnet than your workstation, you will not be able to set the IP address from this workstation. To verify make sure the first 3 sections of the IP address of the IP Security Night Vision Camera corresponds to the first 3 sections of the workstation. Therefore the IP address of the IP Security Night Vision Camera must be set from a workstation on the same subnet.

| | |
|-----------------|---|
| Question | I cannot access the IP Security Night Vision Camera from a web browser. |
| Answer | Other possible problems might be due to the network cable. Try replacing your network cable. Test the network interface of the product by connecting a local computer to the unit, utilizing a standard Crossover (hub to hub) Cable. If the problem is not solved the IP Security Night Vision Camera might be faulty. |

| | |
|-----------------|---|
| Question | Why does the Power LED not light up constantly? |
| Answer | The power supply used might be at fault. Confirm that you are using the provided power supply DC 5V for the IP Security Night Vision Camera and verify that the power supply is well connected. |



| Question | Why does the Link LED not light up properly? |
|----------|--|
| Answer | <ul style="list-style-type: none">• There might be a problem with the network cable. To confirm that the cables are working, PING the address of a know device on the network. If the cabling is OK and your network is reachable, you should receive a reply similar to the following (...bytes = 32 time = 2 ms).• The network device utilized by the IP Security Night Vision Camera is not functioning properly such as hubs or switches. Confirm the power for the devices are well connected and functioning. |

| Question | Why does the IP Security Night Vision Camera work locally but not externally? |
|----------|--|
| Answer | <ul style="list-style-type: none">• Might be caused from the firewall protection. Need to check the Internet firewall with your system administrator.• The default router setting might be a possible reason. Need to double check if the configuration of the default router settings is required. |

| Question | There is bad focus on the IP Security Night Vision Camera, what should be done? |
|----------|---|
| Answer | You need to adjust the IP Security Night Vision Camera focus manually as described in Adjust IP Security Night Vision Camera Focus. |



| | |
|-----------------|--|
| Question | There is poor image quality, how can I improve the image? |
| Answer | <ul style="list-style-type: none">• A probable cause might be the incorrect display properties configuration for your desktop. You need to open the Display Properties on your desktop and configure your display to show at least 65'000 colors for example at least 16-bit.• Applying only 16 or 256 colors on your computer will produce dithering artifacts in the image.• The configuration on the IP Security Night Vision Camera image display is incorrect. Through the Web Configuration Image section you need to adjust the image related parameter for improve images such as brightness, contrast, hue and light frequency. Please refer to the Web Configuration section for detail information. |

| | |
|-----------------|--|
| Question | There are no images available through the web browser? |
| Answer | The ActiveX might be disabled. If you are viewing the images from Internet Explorer make sure ActiveX has been enabled in the Internet Options menu. |

| | |
|-----------------|---|
| Question | Can I capture still images from the NetCamera NV? |
| Answer | Yes you are able to capture still images with the snapshot function directly into web server integrated into NetCamera NV. Please refer to section 3.3. |

APPENDIX C: Adjusting the Camera Focus

To help you get the best image quality, keep in mind that while adjusting the NetCamera NV (Adjust by turning clockwise or counter-clockwise) focus you can preview the image quality from your Web browser.

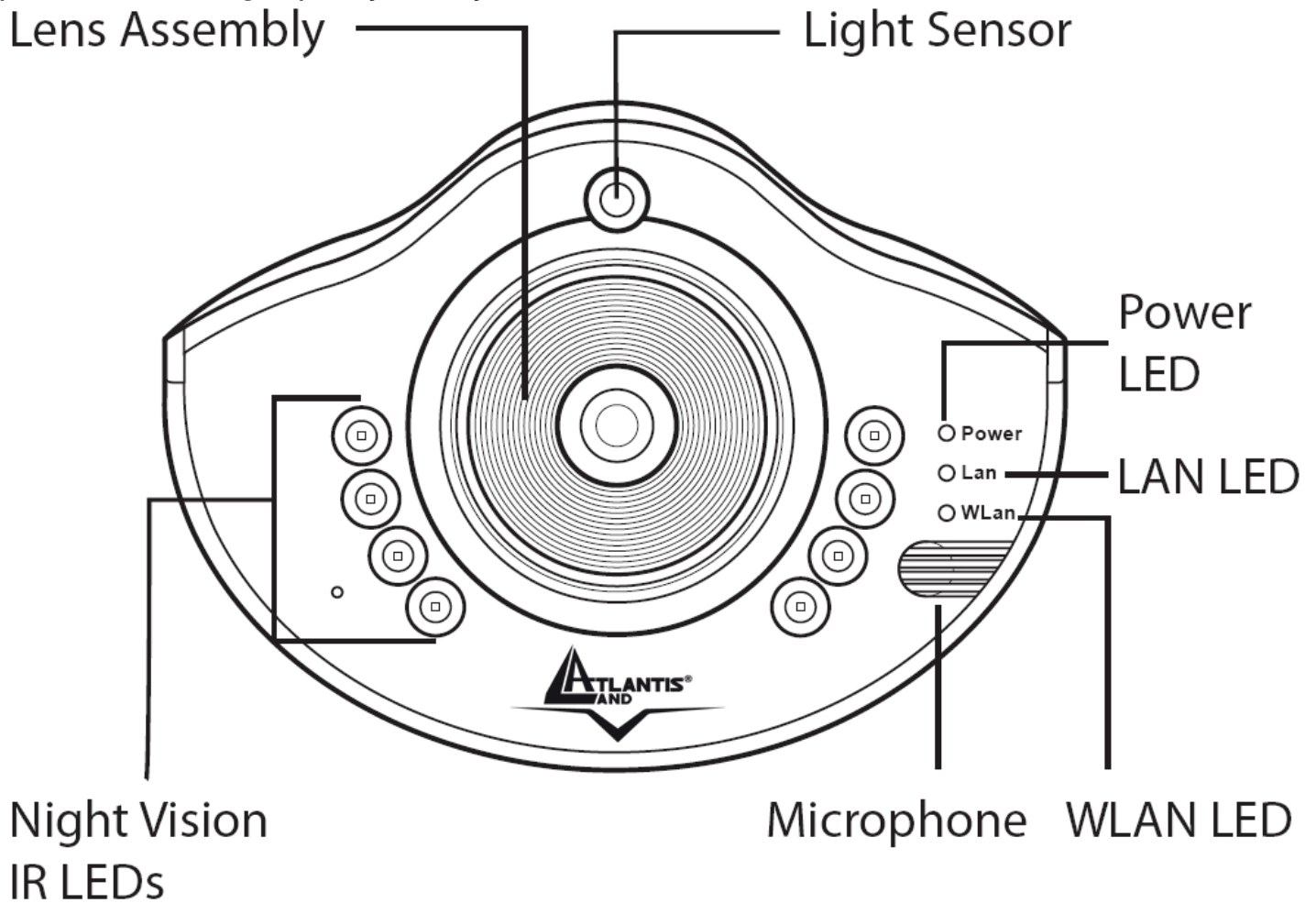

You can further adjust the image quality through the Web Configuration under Setup->Basic->Video. Please refer to section 4.1.4 for further details.



Direct exposure to sunlight may cause permanent damage to the device. Therefore do not expose the Internet Camera's lens directly to sunlight. The NetCamera NV is designed for indoor usage.

APPENDIX D: GPIO

Its back panel contains 3 pairs of connectors (2 input and 1 output) allowing the camera to communicate with different elements of a building, such as electric doors and light switches or security related devices such as alarms.

Most of its applications are security. Warnings to the one break into house/building.

Some people use it to setting fire alarms.

NetCamera NV supports 2 sensors in (DI) and 1 alarm out (DO).

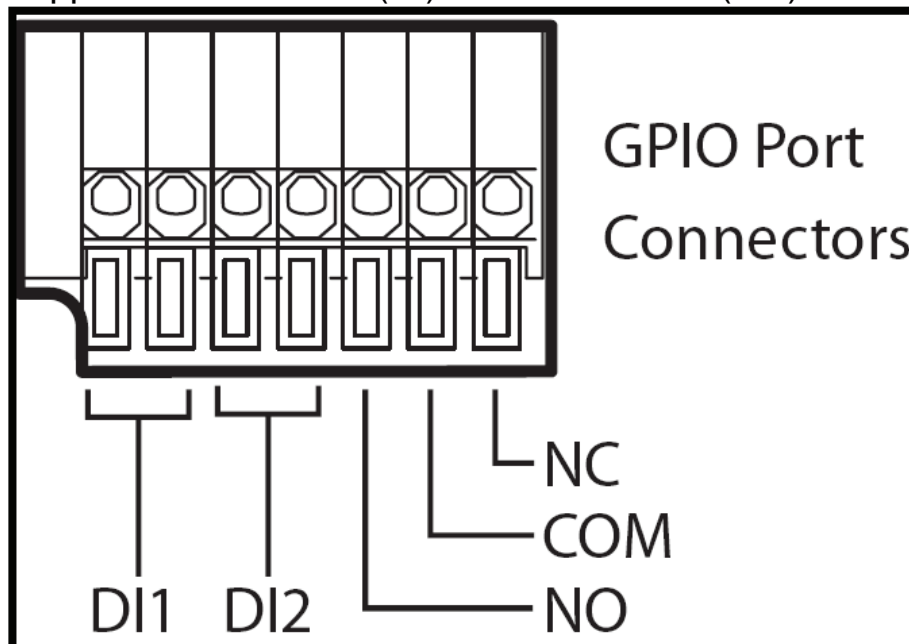





External DI sensors can be attached via the GPIO port at the rear of the camera. The external sensor can be normally open, or normally closed. A normally open sensor (NO/COM) is like an open switch that closes when triggered. A normally closed sensor (NC/COM) is like a closed switch that opens when triggered. This must be set correctly for an external sensor to function properly. You can connect up to two DI sensors to the camera.

An external DO alarm can also be attached to the camera via the GPIO port at the rear of the camera.

Under **DI Configuration**, select **Normal Open** or **Normal Close** for each DI1 and DI2. Click the **Submit** button to confirm all settings.

Under **DO Configuration**, select **Normal Open** or **Normal Close** for the DO alarm. Click the **Submit** button to confirm all settings.

| | |
|---|--|
| NO-normal opened | Triggered |
|  |  |
| NC-normal closed | Triggered |
|  |  |



A normally open sensor (NO/COM) is like an open switch that closes when triggered. In this case the Motion Detection switch on a spot.

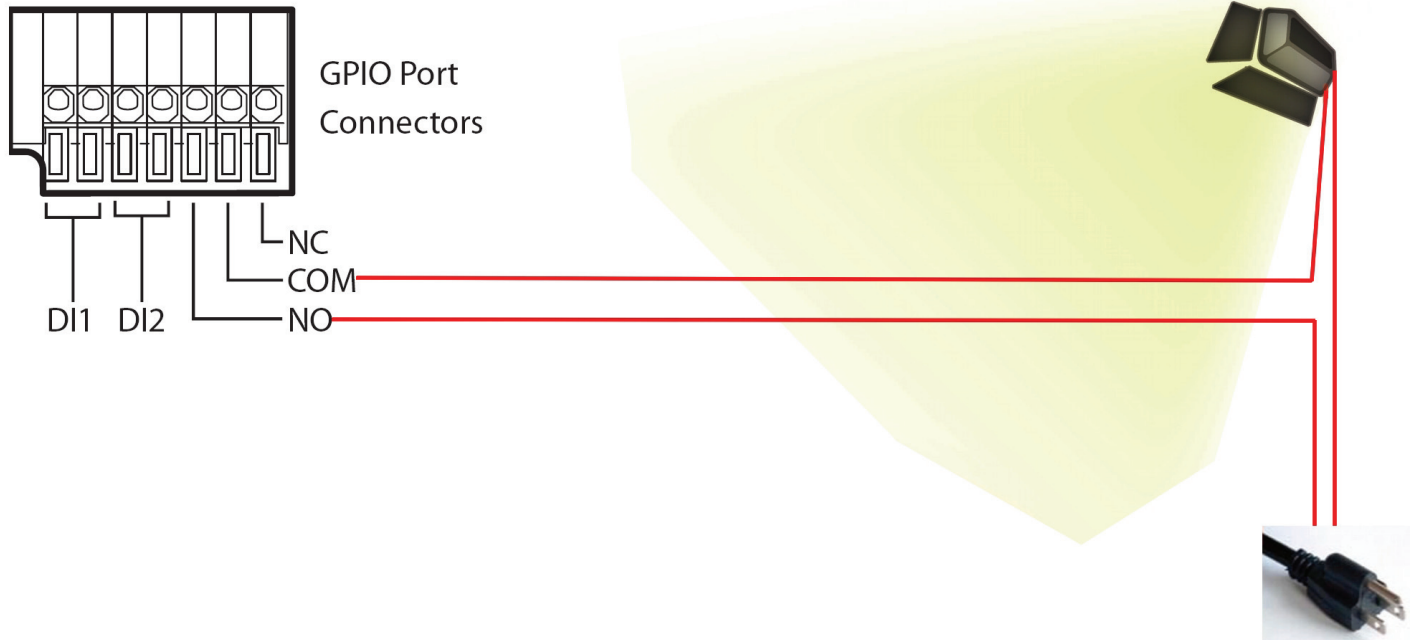

Please check the maximum Voltage/Ampere (DO):
Max 24VDC/1A
Max 125VAC /0.5A



For example, entrance guarding (DO)

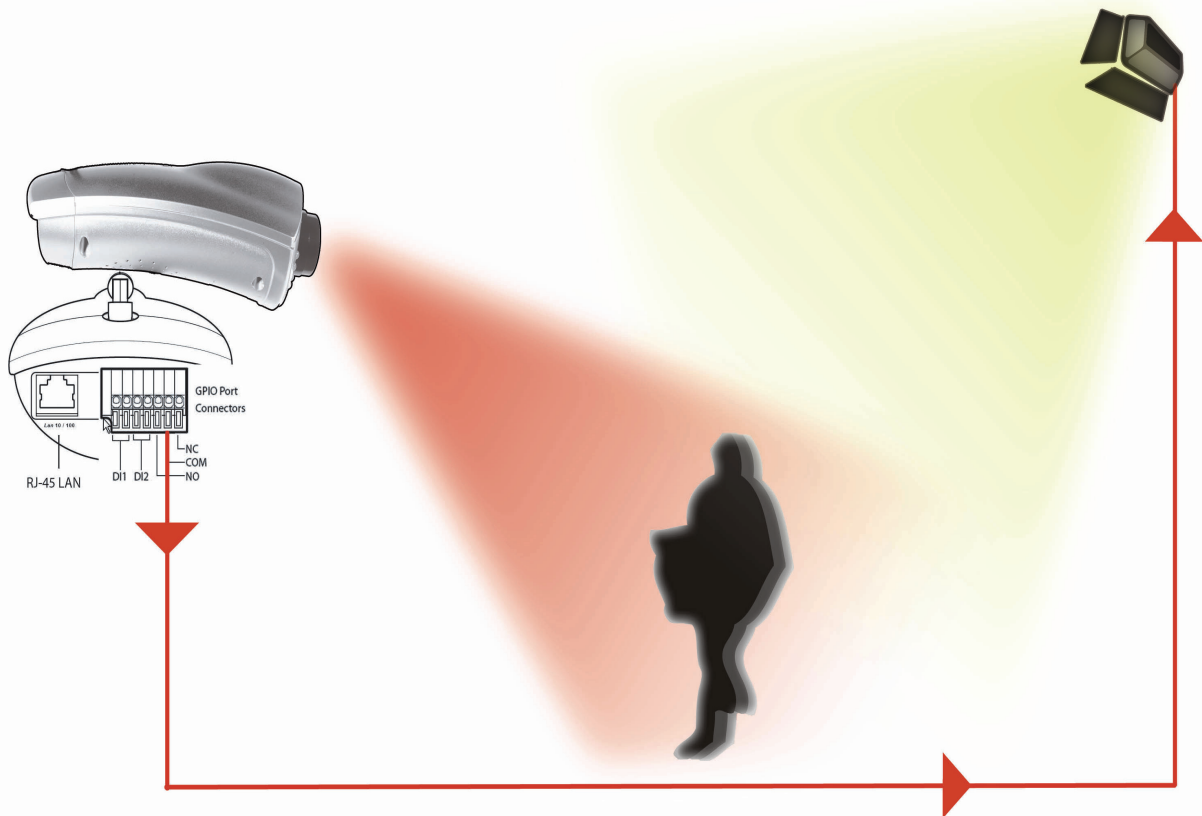



For example, entrance guarding (DO and DI)

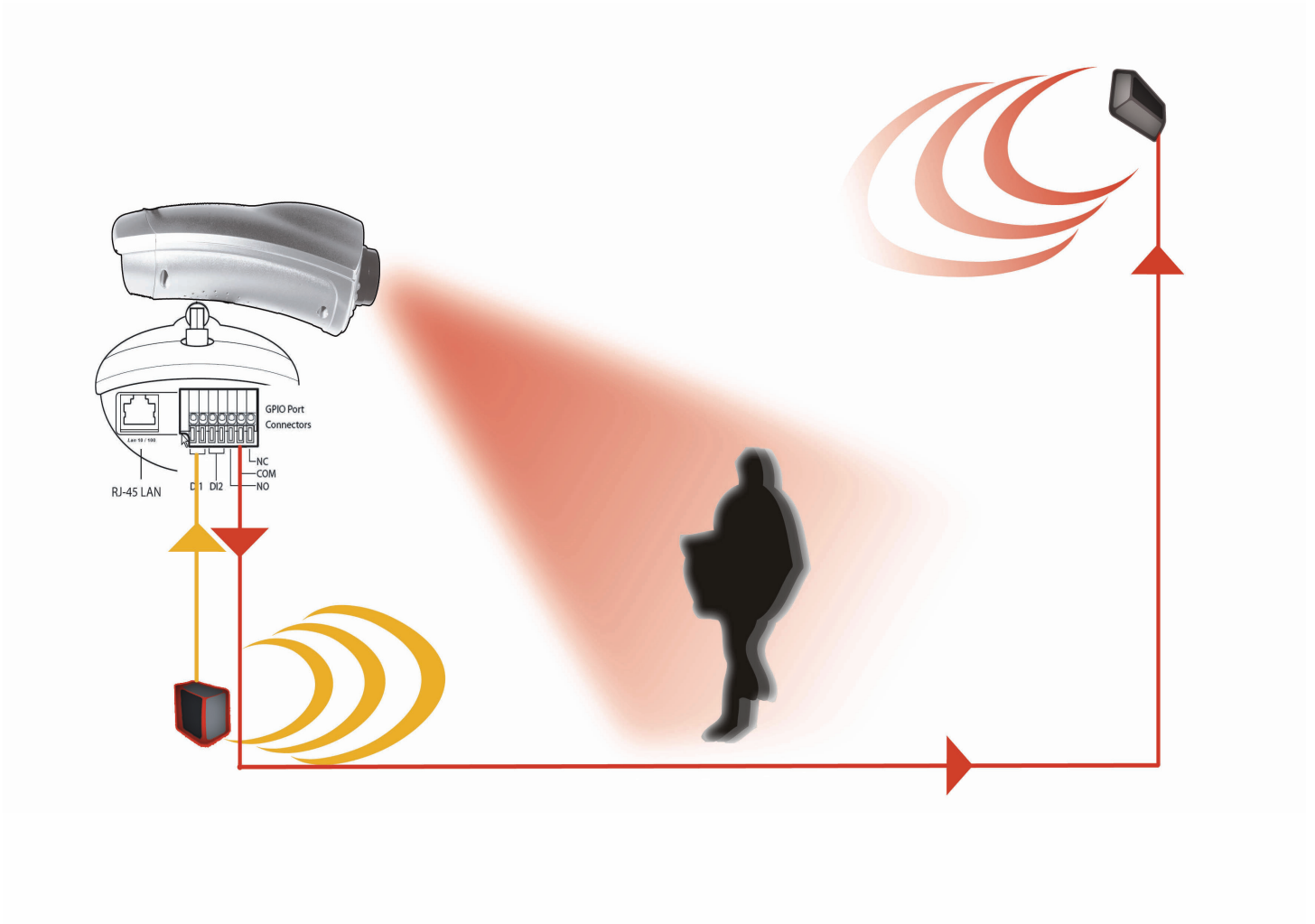



NetCamera NV



APPENDIX E: Glossary of Terms

NUMBERS

- 10BASE-T** 10BASE-T is Ethernet over UTP Category III,IV, or V unshielded twisted-pair media.
- 100BASE-TX** The two-pair twisted-media implementation of 100BASE-T is called *100BASE-TX*.
- 802.11g** An IEEE standard for wireless local area networks. It offers transmissions speeds at up to 54 Mbps in the 2.4-GHz band.

A

- Access point** It is the hardware interface between a wireless LAN and a wired LAN. The access point attaches to the wired LAN through an Ethernet connection.
- Applet** Applets are small Java programs that can be embedded in an HTML page. The rule at the moment is that an applet can only make an Internet connection to the computer from that the applet was sent.
- ASCII** American Standard Code For Information Interchange, it is the standard method for encoding characters as 8-bit sequences of binary numbers, allowing a maximum of 256 characters.
- ARP** Address Resolution Protocol. ARP is a protocol that resides at the TCP/IP Internet layer that delivers data on the same network by translating an IP address to a physical address.
- AVI** Audio Video Interleave, it is a Windows platform audio and video file format.



B

BOOTP

Bootstrap Protocol is an Internet protocol that can automatically configure a network device in a diskless workstation to give its own IP address.

C

Communication

Communication has four components: sender, receiver, message, and medium. In networks, devices and application tasks and processes communicate messages to each other over media. They represent the sender and receivers. The data they send is the message. The cabling or transmission method they use is the medium.

Connection

In networking, two devices establish a connection to communicate with each other.

D

DHCP

Dynamic Host Configuration Protocol was developed by Microsoft a protocol for assigning dynamic IP addresses to devices on a network. With dynamic addressing, a device can have a different IP address every time it connects to the network. In some systems, the device's IP address can even change while it is still connected. DHCP also supports a mix of static and dynamic IP addresses. This simplifies the task for network administrators because the software keeps track of IP addresses rather than requiring an administrator to manage the task. This means a new computer can be added to a network without the hassle of manually assigning it a unique IP address. DHCP allows the specification for the service provided by a router, gateway, or other network device that automatically assigns an IP address to any device that requests one



DNS

Domain Name System is an Internet service that translates domain names into IP addresses. Since domain names are alphabetic, they're easier to remember. The Internet however, is really based on IP addresses every time you use a domain name the DNS will translate the name into the corresponding IP address. For example, the domain name *www.network_camera.com* might translate to *192.167.222.8*.

E

Enterprise network An enterprise network consists of collections of networks connected to each other over a geographically dispersed area. The enterprise network serves the needs of a widely distributed company and operates the company's mission-critical applications.

Ethernet

The most popular LAN communication technology. There are a variety of types of Ethernet, including 10 Mbps (traditional Ethernet), 100 Mbps (Fast Ethernet), and 1,000 Mbps (Gigabit Ethernet). Most Ethernet networks use Category 5 cabling to carry information, in the form of electrical signals, between devices. Ethernet is an implementation of CSMA/CD that operates in a bus or star topology.

F

Fast Ethernet

Fast Ethernet, also called 100BASE-T, operates at 10 or 100Mbps per second over UTP, STP, or fiber-optic media.

Firewall

Firewall is considered the first line of defense in protecting private information. For better security, data can be encrypted. A system designed to prevent unauthorized access to or from a private network. Firewalls are frequently used to prevent unauthorized Internet users from accessing private networks connected to the Internet, especially Intranets all messages entering or leaving the



intranet pass through the firewall, which examines each message and blocks those that do not meet the specified security criteria.

G

Gateway

A gateway links computers that use different data formats together.

Group

Groups consist of several user machines that have similar characteristics such as being in the same department.

H

HEX

Short for hexadecimal refers to the base-16 number system, which consists of 16 unique symbols: the numbers 0 to 9 and the letters A to F. For example, the decimal number 15 is represented as F in the hexadecimal numbering system. The hexadecimal system is useful because it can represent every byte (8 bits) as two consecutive hexadecimal digits. It is easier for humans to read hexadecimal numbers than binary numbers.

I

IEEE

Institute of Electrical and Electronic Engineers.

Intranet

This is a private network, inside an organization or company, that uses the same software you will find on the public Internet. The only difference is that an Intranet is used for internal usage only.

Internet

The Internet is a globally linked system of computers that are logically connected based on the Internet Protocol (IP). The Internet provides different ways to access private and public information worldwide.

Internet address

To participate in Internet communications and on Internet Protocol-based networks, a node must have an Internet address



that identifies it to the other nodes. All Internet addresses are IP addresses

IP Internet Protocol is the standard that describes the layout of the basic unit of information on the Internet (the *packet*) and also details the numerical addressing format used to route the information. Your Internet service provider controls the IP address of any device it connects to the Internet. The IP addresses in your network must conform to IP addressing rules. In smaller LANs, most people will allow the DHCP function of a router or gateway to assign the IP addresses on internal networks.

IP address IP address is a 32-binary digit number that identifies each sender or receiver of information that is sent in packets across the Internet. For example 80.80.80.69 is an IP address, it is the closest thing the Internet has to telephone numbers. When you “call” that number, using any connection methods, you get connected to the computer that “owns” that IP address.

ISP Internet Service Provider, is a company that maintains a network that is linked to the Internet by way of a dedicated communication line. An ISP offers the use of its dedicated communication lines to companies or individuals who can't afford the high monthly cost for a direct connection.

J

JAVA Java is a programming language that is specially designed for writing programs that can be safely downloaded to your computer through the Internet without the fear of viruses. It is an object-oriented multi-thread programming best for creating applets and applications for the Internet, Intranet and other complex, distributed network.

L



LAN Local Area Network a computer network that spans a relatively small area sharing common resources. Most LANs are confined to a single building or group of buildings.

N

NAT Network Address Translator generally applied by a router, that makes many different IP addresses on an internal network appear to the Internet as a single address. For routing messages properly within your network, each device requires a unique IP address. But the addresses may not be valid outside your network. NAT solves the problem. When devices within your network request information from the Internet, the requests are forwarded to the Internet under the router's IP address. NAT distributes the responses to the proper IP addresses within your network.

Network A network consists of a collection of two or more devices, people, or components that communicate with each other over physical or virtual media. The most common types of network are:
LAN – (local area network): Computers are in close distance to one another. They are usually in the same office space, room, or building.
WAN – (wide area network): The computers are in different geographic locations and are connected by telephone lines or radio waves.

NWay Protocol A network protocol that can automatically negotiate the highest possible transmission speed between two devices.

P

PING Packet Internet Groper, a utility used to determine whether a



specific IP address is accessible. It functions by sending a packet to the specified address and waits for a reply. It is primarily used to troubleshoot Internet connections.

PPPoE

Point-to-Point Protocol over Ethernet. PPPoE is a specification for connecting the users on an Ethernet to the Internet through a common broadband medium, such as DSL or cable modem. All the users over the Ethernet share a common connection.

Protocol

Communication on the network is governed by sets of rules called protocols. Protocols provide the guidelines devices use to communicate with each other, and thus they have different functions. Some protocols are responsible for formatting and presenting and presenting data that will be transferred from file server memory to the file server's net work adapter Others are responsible for filtering information between networks and forwarding data to its destination. Still other protocols dictate how data is transferred across the medium, and how servers respond to workstation requests and vice versa. Common network protocols responsible for the presentation and formatting of data for a network operating system are the Internetwork Packet Exchange (IPX) protocol or the Internet Protocol (IP). Protocols that dictate the format of data for transferors the medium include token-passing and Carrier Sense Multiple Access with Collision Detection (CSMA/CD), implemented as token-ring, ARCNET, FDDI, or Ethernet. The Router Information Protocol (RIP), a part of the Transmission Control Protocol/Internet Protocol (TCP/IP) suite, forwards packets from one network to another using the same network protocol.

R

RARP

Reverse Address Resolution Protocol, a TCP/IP protocol that allows a physical address, such as an Ethernet address, to be translated into an IP address.

RJ-45

RJ-45 connector is used for Ethernet cable connections.



- Router** A router is the network software or hardware entity charged with routing packets between networks.
- S**
- Server** It is a simple computer that provides resources, such as files or other information.
- SMTP** The Simple Mail Transfer Protocol is used for Internet mail.
- SNMP** Simple Network Management Protocol. SNMP was designed to provide a common foundation for managing network devices.
- Station** In LANs, a station consists of a device that can communicate data on the network. In FDDI, a station includes both physical nodes and addressable logical devices. Workstations, single-attach stations, dual-attach stations, and concentrators are FDDI stations.
- Subnet mask** In TCP/IP, the bits used to create the subnet are called the subnet mask.
- T**
- (TCP/IP)** Transmission Control Protocol/Internet Protocol is a widely used transport protocol that connects diverse computers of various transmission methods. It was developed by the Department of Defense to connect different computer types and led to the development of the Internet.
- Transceiver** A transceiver joins two network segments together. Transceivers can also be used to join a segment that uses one medium to a segment that uses a different medium. On a 10BASE-5 network, the transceiver connects the network adapter or other network device to the medium. Transceivers also can be used on 10BASE-



2 or 10BASE-T networks to attach devices with AUI ports.

U

UDP The User Datagram Protocol is a connectionless protocol that resides above IP in the TCP/IP suite

ULP The upper-layer protocol refers to Application Layer protocols such as FTP,SNMP, and SMTP.

User Name The USERNAME is the unique name assigned to each person who has access to the LAN.

Utility It is a program that performs a specific task.

UTP Unshielded twisted-pair. UTP is a form of cable used by all access methods. It consists of several pairs of wires enclosed in an unshielded sheath.

W

WAN Wide-Area Network. A wide-area network consists of groups of interconnected computers that are separated by a wide distance and communicate with each other via common carrier telecommunication techniques.

Windows Windows is a graphical user interface for workstations that use DOS.

Workgroup A workgroup is a group of users who are physically located together and connected to the same LAN, or a group of users who are scattered throughout an organization but are logically connected by work and are connected to the same network group.



Workstations

Workstation refers to the intelligent computer on the user's desktop. This computer may be an Intel-based PC, a Macintosh, or a UNIX-based workstation. The workstation is any intelligent device a user works from.



APPENDIX F: Technical Features

TECHNICAL FEATURES

CMOS Sensor

Number of effective pixels: 307200 pixels (VGA)

Resolution: 640 x 480 pixel

Lens Type: C3 Mount Lens (removable)

Focal length: f=3.6mm

F-number: F2.0

Focus Extent: 20 cm - ∞

Image (Video Setting)

Image compression: MJPEG

Frame rate: 30fps@QQVGA, 25fps@QVGA, 15fps@VGA

Compression Rate selection: 2 levels

Video resolution: 160x112, 320x240, 640x480

Upside down and Mirror: Yes

Brightness/ Contrast /Saturation/Sharpness/HUE/Gamma control

Night Vision: 8 x IR LEDs (auto/manual)

Audio

MIC Input: Internal MIC (mono)

Audio Compression: PCM 64Kbit

Hardware Interface

LAN Connector: One RJ-45 port to connect to 10/100Mbps Ethernet, auto-sensed

LED Indicator: Power LED, LAN

Power Supply: DC 5V, switching type

GPIO: 2 x Sensor IN / 1 x Sensor OUT

Communication Support

Communication: 10/100Mbps Ethernet

Communication protocol: HTTP, TCP/IP, UDP, ARP, ICMP, DHCP, PPPoE, DDNS, DNS, FTP

System

CPU: MIPS/JPEG encode chip (VGA)



System Requirements

Local Area Network: 10Base-T Ethernet or 100Base TX Fast Ethernet
CPU: Intel Celeron 1.5GHz or above (Intel Pentium 4 is preferred)
Memory Size: 128 MB (256 MB recommended)
VGA card resolution: 800x600 or above
Internet Explorer 5.0 or above (ActiveX)

Advanced Features

Hardware motion detection and send e-mail (with snap shot) when motion detected
GPIO: Sensor IN, Alarm Out
Single Frame Image Snap shot (manual)
Record (AVI, manual)
FTP / PPPoE / Dynamic DNS Clients

Operating environment

Operating temperature: 5°C ~ 30°C
Storage temperature: -25°C ~ 50°C
Humidity: 20% ~ 80% non-condensing

Package Contents:

One IP Security Night Vision Camera
One Quick Installation Guide
One Installation CD Rom
One Metal Clip (wall mounting)
One DC Power Adapter
One RJ-45 Ethernet Cable

All rights registered

Microsoft and Windows are registered trademarks of Microsoft Corporation

All trade names and marks are registered trademarks of respective companies

Specifications are subjected to change without prior notice. No liability for technical errors and/or omissions

Performance and Throughput are influenced by many factors (interference, noise, environments)



NetCamera NV



Atlantis Land S.p.A.
Viale De Gasperi, 122
Mazzo di Rho – MI – Italy
info@atlantis-land.com
sales@atlantis-land.com

Where solutions begin

ISO 9001:2000 Certified Company

Free Manuals Download Website

<http://myh66.com>

<http://usermanuals.us>

<http://www.somanuals.com>

<http://www.4manuals.cc>

<http://www.manual-lib.com>

<http://www.404manual.com>

<http://www.luxmanual.com>

<http://aubethermostatmanual.com>

Golf course search by state

<http://golfingnear.com>

Email search by domain

<http://emailbydomain.com>

Auto manuals search

<http://auto.somanuals.com>

TV manuals search

<http://tv.somanuals.com>