



# **Universal Telephone Interface**

## **UTI1 Model**

Installation and Use Manual

© 2004 Bogen Communications, Inc.  
All rights reserved.  
Specifications subject to change without notice.  
54-2095-01A 0406

© 2004 Bogen Communications, Inc.

All Rights Reserved. Printed in Taiwan.

### Notice

Every effort was made to ensure that the information in this manual was complete and accurate at the time of printing. However, information is subject to change.

### FCC Statement (Part 15) - Radio Frequency Interference

The Universal Telephone Interface (UTI1) generates and uses radio frequency energy and if not installed and used in strict accordance with the manufacturer's instructions, may cause interference to radio and television reception. Testing is being conducted for compliance with the limits for a Class B device in accordance with the specifications in Part 15 of the FCC Rules and Canadian D.O.C. regulations. This testing is designed to provide reasonable protection against such interference. However, there is no guarantee that interference will not occur in a particular installation. If this equipment does cause interference to radio or television reception, which can be determined by turning the UTI1 unit off and on, the user is encouraged to try to correct the interference by one or more of the following measures:

- Reorient the radio or TV receiving antenna.
- Relocate the UTI1 unit with respect to the radio or TV receiver or vice versa.
- Plug the UTI1 unit into a different outlet so that it and the radio or TV receiver are on different branch circuits.

If necessary, the user should consult the dealer or an experienced radio/television technician for additional suggestions. The user may find the following booklet, "How To Identify and Resolve Radio-TV Interference Problems," helpful. This booklet was prepared by the Federal Communications Commission (FCC) and is available from the U.S. Government Printing Office, Washington, DC 20402. Stock order No. 004-000-00345-4.

### Federal Communications Commission (FCC) Statement (Part 68)

This equipment is component registered with the Federal Communications Commission (FCC) in accordance with Part 68 of its rules. In compliance with the rules, be advised of the following:

Registered equipment may not be used with Coin Telephone Lines. Equipment may be used with Party Lines in areas where state tariffs permit such connections and when equipment is adaptable for such service.

This equipment is registered as follows:  
Registration Number - CD2PA14BUT11  
Ringer Equivalence - 1.4B

If trouble is experienced, the equipment should be disconnected from the interface to determine if this equipment, or the telephone line, is the trouble source. If the equipment is determined to be malfunctioning, it should not be reconnected until repairs are effected.

Repairs to this equipment, other than routine repairs, can be made only by the manufacturer or its authorized agents.

If the equipment causes harm to the telephone network, the local telephone company may temporarily discontinue your service and, if possible, notify you in advance. If advance notice is not practical, you will be notified as soon as possible. You will be given the opportunity to correct the problem and informed of your right to file a complaint with the FCC.

The local telephone company may make changes in its facilities, operations, or procedures that could affect the proper functioning of your equipment. If they do, you will be given adequate notice in writing to allow you an opportunity to maintain uninterrupted telephone service.

### Important Safety Information

Always follow these basic safety precautions when installing and using the system:

1. Read and understand all instructions.
2. Follow all warnings and instructions marked on the product.
3. DO NOT block or cover the ventilation slots and openings. They prevent the product from overheating. DO NOT place the product in a separate enclosure or cabinet, unless proper ventilation is provided.
4. Never spill liquid on the product or drop objects into the ventilation slots and openings. Doing so may result in serious damage to the components.
5. Repair or service must be performed by a factory authorized repair facility.
6. The product is provided with a UL-CSA approved, 3-wire ground type plug. This is a safety feature. DO NOT defeat the safety purpose of the grounding type plug. DO NOT staple or otherwise attach the AC power supply cord to building surfaces.
7. DO NOT use the product near water or in a wet or damp place (such as a wet basement).
8. DO NOT use extension cords. The product must be installed within 6 feet of a grounded outlet receptacle.
9. DO NOT install telephone wiring during a lightning storm.
10. DO NOT install telephone jacks in a wet location unless the jack is specifically designed for wet locations.
11. Never touch uninsulated wires or terminals, unless the line has been disconnected at the paging or controller interface.
12. Use caution when installing or modifying paging or control lines.

# Contents

<b>UTI1 Feature Callouts .....</b>	<b>4</b>
<b>Introduction .....</b>	<b>5</b>
Voice Channel .....	5
Background Music .....	5
Signaling Tones .....	5
Other Features .....	5
Package Contents .....	5
<b>Installation .....</b>	<b>6</b>
Wall Mounting .....	6
<b>Telephone Interface Wiring Connections &amp; Setup .....</b>	<b>7-10</b>
Telephone System Connections.....	7
Trunk Disconnect .....	7
PBX Loop Start Trunk Port .....	7
PBX Ground Start Trunk Port .....	8
PBX Page Port Contact.....	8
PBX Page Port VOX .....	9
PBX Analog Station Port .....	9
Override Input.....	10
<b>Other Connections .....</b>	<b>11</b>
Night Ringer .....	11
Tone Trigger .....	11
Paging Output Connections .....	11
Background Music Input .....	11
Aux Contacts .....	11
<b>Controls .....</b>	<b>12</b>
Paging Level.....	12
Music Level .....	12
Music Mute Level.....	12
Tone Level.....	12
Limiter Threshold .....	12
<b>Tones.....</b>	<b>13</b>
Pre-Announce/Confirmation Tone .....	13
Tone Trigger .....	13
Override Tone .....	13
Setup Tone.....	13
<b>Reference .....</b>	<b>13</b>
How to Page.....	13
Priority Levels .....	13
<b>System Programming.....</b>	<b>14-15</b>
Default Timer .....	14
VOX Timer .....	14
DTMF Block .....	14
Setup Tone.....	14
Reset Default Values .....	14
AUX Relay Contact .....	15
<b>Feature Codes and Defaults.....</b>	<b>17</b>
<b>Specifications .....</b>	<b>18</b>
<b>Block Diagram.....</b>	<b>19</b>
<b>Limited Warranty .....</b>	<b>20</b>

# UTI1 Feature Callouts

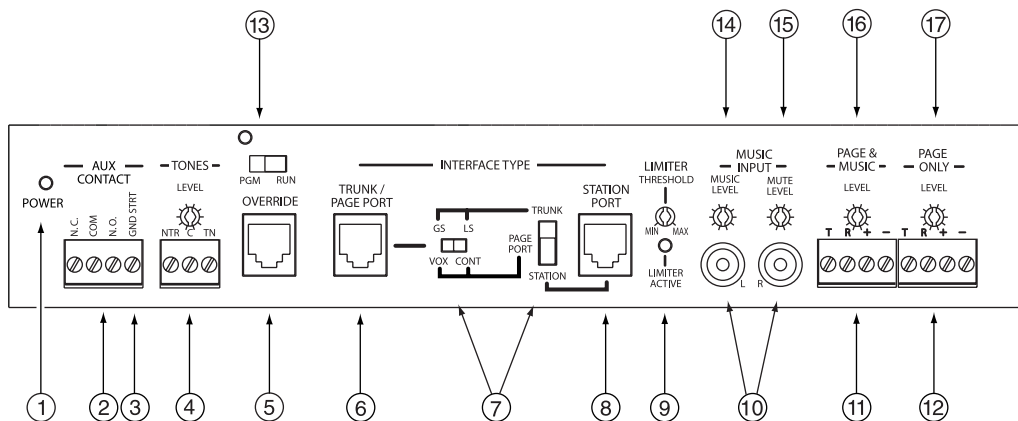

1. **Power Indicator** - Illuminates when AC power has been applied to the unit.
2. **AUX Contact Terminals** - Provide connections for normally open and normally closed contact closures. The contact closure can be programmed to activate during paging, night ring, tone, override, or any combination (refer to *System Programming*).
3. **Ground Start Terminal** - Connection for PBX ground. Used only when the ground start interface is selected.
4. **Tone Terminals / Tone Level Control** - Terminals provide connections to night ring and tone trigger inputs. Tone Level Control sets the level of all tones produced by the system.
5. **Override** - Secondary paging input with higher priority than TRUNK/PAGE PORT or STATION mode inputs. Connects to either loop start trunk or dry audio signal with contact closure.
6. **Trunk/Page Port** - Primary paging interface to telephone system when UTI1 is set to trunk or page port mode type interface.
7. **Interface Type Slide Switches** - Sets telephone interface type for the UTI1.
8. **Station Port** - Primary paging interface to telephone switch when UTI1 is set to station mode type interface.
9. **Limiter Threshold / Limiter Active LED** - Control and indicator for output limiter function.
10. **Music Input Jacks** - Stereo summing input for background music source.
11. **Page & Music Terminals** - Provides connections to the paging system (background music and voice paging) and the 24V DC power supply.
12. **Page Only Terminals** - Provides connections to the paging system (voice page only - no music) and the 24V DC power supply.
13. **Program/Run Switch & LED** - Used to switch unit to program mode. The LED will light when unit is in PROGRAM mode.
14. **Music Level Control** - Music Level sets background music level.
15. **Music Mute Control** - Music Mute sets music mute level during paging.
16. **Page & Music Level Control** - Page & Music Level controls the level of page & music output.
17. **Page Only Level Control** - Page Only Level controls the level of page only output.

# Introduction

---

The UT11 Paging System is a paging and signaling system. The system provides the following features and functions:

## Voice Channel

- Single-zone paging
- Telephone interfaces:
  - loop start trunk
  - ground start trunk
  - station access (analog ring-up)
  - page port contact closure activation
  - page port voice activation
- Override paging (using loop start trunk or page port contact closure activation)
- Two audio outputs (both with level controls):
  - paging and background music
  - paging only
- Each output can provide audio for 150 Bogen one-way amplified speakers, also compatible with 70V amp inputs
- Pre-Announce/Confirmation Tone
- Adjustable Automatic Level Control with threshold and active indicator

## Background Music

- High impedance transformer isolated BGM input with volume control
- Variable music mute

## Signaling Tones

- Night Ringer (contact closure activation)
- Tone Trigger (tone and duration selectable, closure-activated)

## Other Features

- C-form contact set with programmable activation events
- Non-volatile memory for setup data (no backup battery required)
- Setup Tone to assist in volume setting, etc.
- Pluggable terminal strips
- Microcontroller-based operation
- DTMF setting of operating parameters

## Package Contents

- (1) UT11
- (1) Installation and Use Manual

# Installation

---

## Wall Mounting

Mounting to a plywood backboard or studs:

1. Hold the unit level against the surface to which it will be mounted.
2. Mark where the mounting screws should be positioned.
3. Set the unit aside and install the screws leaving about  $\frac{1}{4}$ " of the screws sticking out of the surface.
4. Slip the unit over the screws and tighten them snugly.

# Telephone Interface Wiring Connections & Setup

---

## Telephone System Connections

The UT11 connects to virtually any telephone system: PBX station lines and CO lines, PBX loop start trunk ports, PBX ground start trunk ports, and page ports.

Interface installation consists of setting the slide switches and connecting with modular (RJ11) telephone plugs. Refer to the appropriate procedure in this section to connect the UT11 to the telephone system.

*Note: In all cases, make sure that power to the UT11 is disconnected before performing the installation.*

## Trunk Disconnect

The UT11 includes a trunk disconnect feature. The purpose of the trunk disconnect feature is to release the UT11 from the trunk port in the event a user does not hang up the phone properly after making a page. If the UT11 does not detect voice for the interface VOX time-out period, or if the interface default timer expires, the UT11 will attempt to release from the trunk. When using the trunk disconnect feature with a trunk interface, the PBX must have disconnect supervision available on the trunk port connected to the UT11. The trunk disconnect feature is enabled by default and can be disabled. (Refer to *System Programming*.) To set the VOX and default timers refer to *System Programming*.

## PBX Loop Start Trunk Port

In this configuration, the unit supplies a 24V talk battery and loop current detection. When the unit detects a loop resistance between Tip and Ring, it activates. When the loop opens, the page ends. The unit follows the status of the trunk port.

Before configuring the UT11 for a loop start trunk port, make sure that the power is disconnected and all other connections are completed. Move the slide switches on the UT11 to the positions shown below. Use a modular telephone cord to connect the module to the phone system.

The center two conductors are Tip and Ring (24V DC) and have a specific polarity as shown in the figure to the right. If the polarity that the trunk requires is opposite, you can use a reversing modular cord to make the connection or reverse the connection through a modular block. The trunk disconnect feature is available in this mode.

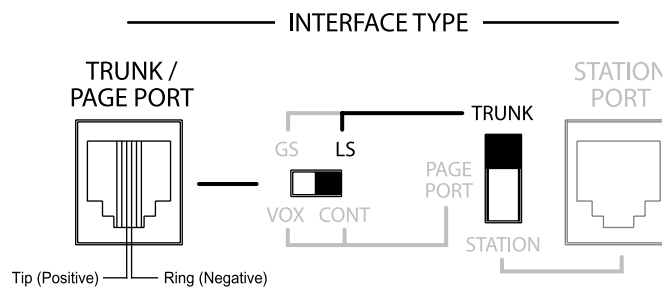





## PBX Page Port VOX

In this configuration, the unit activates when audio on the page input is detected. Loss of audio allows the VOX timer to expire and ends the page.

Make sure that the power is disconnected and all other connections are completed before proceeding. Move the slide switches on the UT11 to the positions shown below. Use a modular telephone cord to connect the module to the phone system. The center two conductors are used for dry audio and are not polarity sensitive. The Trunk disconnect feature is not available in this mode.

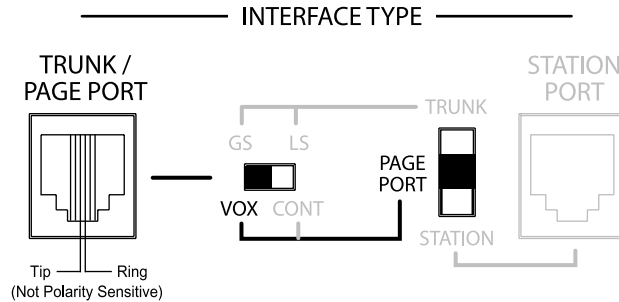

## PBX Analog Station Port

In this configuration, the unit answers after detecting ring. As soon as it answers, the default timer and VOX timer are started. The default timer determines the maximum length of any page. The VOX timer repeatedly resets as long as audio is detected on the line. If no audio is detected within the VOX time period, then the page will end. If audio continues to be detected, then the default timer will control page length. The unit will disconnect if a loss of loop current is detected.

Make sure that the power is off and all connections are completed before proceeding. Move the interface slide switch on the UT11 to STATION. The other interface slide switch is not used and can be in any position. Use a modular telephone cord (minimum 2-conductor) to connect the UT11 Station Port RJ11 to the phone system. The center two conductors are Tip and Ring and are not polarity sensitive (see below). Set Default and VOX timers (see *System Programming*). The timers can be independently inhibited.

*Note: The default timeout is factory set to 30 seconds, and the VOX timeout is set to 6 seconds. If both the default and VOX timers are inhibited, the only way to release the system from the station line is through the use of a Calling Party Control (CPC) pulse.*

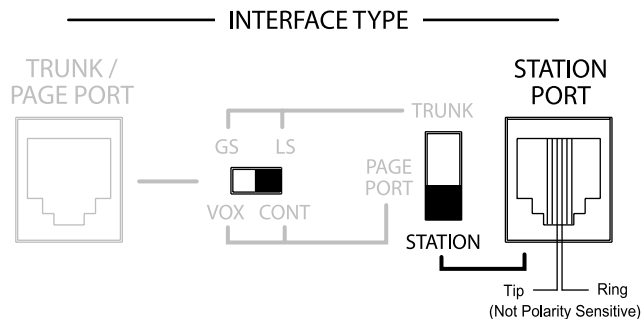

## Override Input

The Override is a non-programmable feature that lets the caller take priority over all paging functions and make a page to all speakers. The feature can be activated using a loop start trunk or dedicated telephone.

The center two conductors interface directly to a Loop Start Trunk or a dedicated phone. When the trunk becomes active, the UT11 goes into Override mode. A contact closure and dry audio source can also be used for the Override Input. The two conductors flanking the talk battery conductors provide a dry audio gateway into the system override. Override is activated by shorting the outermost conductors.

Maximum contact closure resistance is 1000 ohms. Open collector type outputs for controlling a page may also be used. The Override feature includes a quad beep pre-announce tone that can be enabled or inhibited. (The default is inhibited.)

Make sure that the power is disconnected and all other connections are completed before proceeding. Plug modular cord into OVERRIDE (RJ11) jack.

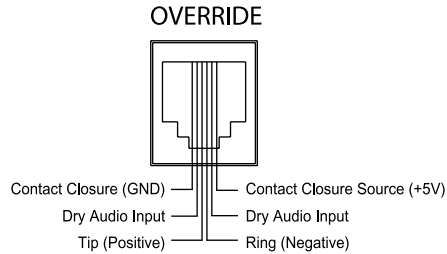

# Other Connections

## Night Ringer

The UT11 night ringer signaling feature is designed to alert personnel to incoming calls after normal business hours. The feature is activated by a contact closure from the PBX.

The night ringer normally sounds a simulated ring tone, but can be programmed to sound a chime tone.

To physically connect the night ringer wiring:

1. Make sure that the power is disconnected.
2. Wire the contact closure used for night ring to the NTR (+5V) and C terminals on the UT11. Maximum contact resistance for contact closure activation is 1000 ohms. Open collector type outputs for controlling a page may also be used.

*Note: The Night Ring feature has priority just above background music. There is a 5-second delay after the night ring stops before background music is restored (bridges inter-ring pause).*

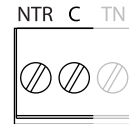

## Tone Trigger

The UT11 tone trigger input is typically used to signal shift changes using a contact closure pair from an external master clock or as a doorbell annunciator. The tone type is programmable. This is set in programming. Refer to *System Programming* section.

To physically connect the tone trigger wiring:

1. Make sure that the power is disconnected.
2. Wire the contact closure used for tone trigger to the TN (+5V) and C terminals on the UT11. Maximum contact resistance for contact closure activation is 1000 ohms. Open collector type outputs for controlling a page may also be used.

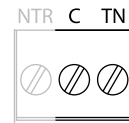

## Paging Output Connections

There are two paging outputs on the UT11. One output supplies both paging and background music, while the other supplies only paging. The paging outputs are intended to connect to amplified speakers, but are also compatible with amplifier inputs as well. The Tip (T) and Ring (R) connections are transformer-isolated audio outputs with an output impedance of 8 ohms. Connect these to the audio inputs of the amplified speakers for driving up to 150 speaker inputs. The + and - terminals provide 24V DC for powering the amplified speakers. The UT11 can supply a total of 1A @ 24V DC.

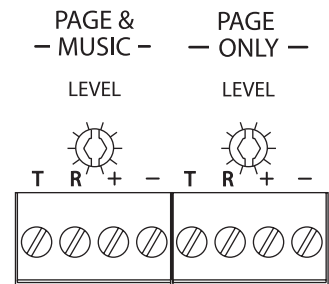

## Background Music Input

The UT11 system provides a high-impedance, transformer-isolated summed stereo background music input. Mono sources can be connected to either RCA.

## AUX Contacts

The UT11 system provides a dual form contact rated at 2A @ 30V DC and 0.6A @ 125V AC, which can be used to activate external equipment. The relay can be programmed to change state when specific events or combination of events (time tone, override, night ring, paging) occur. Refer to the *System Programming* section.

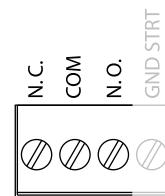

# Controls

---

## Paging Level

The UT11 has controls for adjusting the audio level of each output independently. These serve as master level controls that allow for overall system control. Setting the initial volume to half is a good starting point. If the speakers have their own level control, then the installer will have to determine the proper setting for each speaker depending on the application. Clockwise increases level, counterclockwise decreases level.



## Music Level

The UT11 has a background music input level control. Once the page level has been adjusted set the music level control to the desired background music level. Clockwise increases level, counterclockwise decreases level.

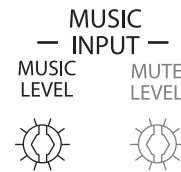

## Music Mute Level

The music mute level sets the level to which the background music is muted during paging. Once all paging levels and music levels have been set, make a page and adjust the mute level as desired. Clockwise increases mute level, counterclockwise decreases mute level. Fully clockwise fully mutes background music.

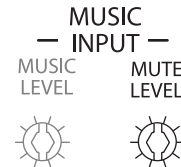

## Tone Level

The tone level control sets the level for all tones. Clockwise increases level, counterclockwise decreases level.

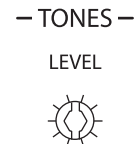

## Limiter Threshold

Because not everyone speaks at the same level, the UT11 includes a limiter threshold control that prevents loud voices from booming out of the paging system's speakers. The limiter restricts the input signal to a preset level regardless of the input level. To set the limiter, follow the directions below.

1. Turn off the limiter by rotating the control fully clockwise.
2. Hold the telephone handset in a normal position and speak in a normal voice distinctly into the mouthpiece. Adjust the limiter control until the limiter active LED starts to come on.

Volume can be adjusted without disturbing the limiter adjustment by using the Page & Music or Page Only level controls.

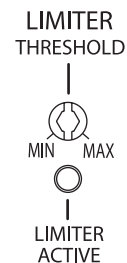

# Tones

---

## Pre-Announce/Confirmation Tone

This tone can be set to be heard at the speakers being paged or the calling telephone or both. It is either a chime or beep (default). The pre-announce/confirmation tone can also be inhibited. See *System Programming* to change or inhibit this tone.

## Tone Trigger

This tone is activated when the TN and C terminals are shorted together. This tone has the second highest priority after override. Several tone options are available.

**2 - 7 Second Tone Burst** - This is a tone burst that, once a momentary closure is detected at the tone trigger input, will sound for the set duration one time. The UTI1 will not respond to the tone trigger input while the tone is in progress. If the closure is still present at the tone trigger input upon completion of the tone, then the UTI1 will not sound the tone again until the closure is removed and applied again.

**Tone Follow Contact** - This is a tone burst that will sound continuously as long as a contact closure is present at the tone trigger input.

**Double Chime Tone** - This is a chime tone that will sound twice when a closure is detected at the tone trigger input. The UTI1 will not respond to the tone trigger input while the tone is in progress. If the closure is still present at the tone trigger input upon completion of the tone, the UTI1 will not sound the tone again until the closure is removed and applied again.

**Chime Tone Follow Contact** - This is a chime tone that will sound continuously as long as a contact closure is present at the tone trigger input.

**Slow Whoop Follow Contact** - This is a slow whoop tone that will sound continuously as long as a contact closure is present at the tone trigger input.

## Override Tone

This tone is produced when override is activated. It produces a quad beep pre-announce tone that can be enabled or inhibited. (The default is inhibited). See *System Programming* to enable the tone.

## Setup Tone

This tone can be activated only when the system is in Program mode (set with Run/Program switch). It is an interrupted tone which can be used by the installer to check speaker operation, set operational level of speakers. See *System Programming* to enable the tone.

*Note: The volume level of all of the above tones are controlled by the TONE VOLUME control. All tones play at the same level. Clockwise rotation of the control increases the level. Counterclockwise rotation of the control decreases the level.*

# Reference

---

## How To Page

1. Dial the paging access number for your telephone system.
2. Listen for the confirmation tone if enabled.
3. Make the page and hang up when finished.

## Priority Levels

The following is a list of the priority operation of the UTI1.

Highest	Override
	Tone Trigger
	Voice Page
	Night Ring
Lowest	Background Music



# System Programming

---

System programming lets you set certain UT11 options and tone features using the DTMF keys of a telephone. All programming is accomplished through the Override jack on the UT11.

To program the UT11 system, follow these instructions:

1. Place the PROGRAM/RUN switch to the PROGRAM position. The green LED will illuminate.
2. Access the UT11 override port (either use a single 2500-type telephone or Test Set).
3. You will hear 3 beep tones indicating access to the programming mode.
4. Dial the Feature Code and any required input data for the option you wish to program.
5. Press the [#] key to store the programming data. If you don't dial the [#], then the data is not stored. A double beep will sound to confirm the entry.

*Note: After you have entered a Feature Code (and any other data), you must press the [#] key to enter it into the system. If the system accepts the code (and data), you will hear a short double beep confirming that the data has been stored in the system. Continue with the next Feature Code immediately after the confirming double beep. If the information is not accepted, you will hear a busy tone. In this case, you should hang up, check the code and the data, then re-access the system and try again.*

6. Once you have finished all programming, you must first hang up the programming phone and then place the Program/Run switch in the Run position. The green LED will go out.

## Default Timer

If the UT11 is connected to a PBX station port, or a trunk port with the trunk disconnect feature enabled, you can set the maximum page duration (default timer). The factory setting for this timer is 30 seconds. To change the time, enter the Feature Code and the new 2-digit number corresponding to the time desired. The 2-digit number represents default time in multiples of 10 seconds. (Example: 03 = 30 seconds; 12 = 120 seconds.) If you wish to inhibit the default timer, enter "00" for the time data.

## VOX Timer

If the UT11 is connected to a station port, page port VOX, or trunk port with the trunk disconnect feature enabled, you can set the time duration for the VOX time out. The factory setting is 6 seconds. To change the time, enter the Feature Code "51" followed by a single digit from 1 to 9, corresponding to 1 to 9 seconds. To inhibit the timer, enter the Feature Code followed by "0".

## DTMF Block

DTMF Block can be enabled or disabled (Feature Codes 40 and 41). If enabled, DTMF Block suppresses DTMF tones issued to the UT11 so that only a small portion of the tone will be heard over the paging system. If external DTMF controlled devices are connected to the output T/R terminals of the UT11, the DTMF Block feature will have to be disabled in order for these devices to receive DTMF tones. In this configuration the DTMF tones will be heard over the paging system.

## Setup Tone

The setup tone is a beeping tone available to assist in the adjustment of speaker volume and testing the system. The setup tone is only available in the programming mode. To activate the setup tone, dial "00" and leave the phone off hook. To deactivate the setup tone, hang up the phone.

## Reset Default Values

A Feature Code is available to reset the UT11 system to the original factory default values. Wait for a confirmation tone before hanging up.

# Warning!

Erased data cannot be recovered.

## AUX Relay Contact

The UT11 allows the installer to program a number of different parameters to control the way in which the AUX relay contacts activate. The UT11 allows programming of which input events (Override, Tone Trigger, Page, and Night Ring) it will respond to, whether it will respond to the event only (Event Driven Mode) or to a combination of the event and its place in the priority structure (Priority Driven Mode), and if the contact will respond during the event (No Delay) or after the event ends (Delay).

### Event Enable/Disable

The UT11 monitors for 4 types of input events: Override, Tone Trigger, Page, and Night Ring. When one of these inputs is activated, the UT11 detects that as a particular event. Through programming, the installer can decide which of these 4 events the UT11 will allow to activate the AUX relay. Setting the event to Enable allows the AUX contact to respond to that event.

For example, if the application requires that the AUX relay contacts respond only when the night ring input is active, the installer would enable the night ring event and disable all other events (override, tone trigger and page).

It is possible to enable multiple events. In this case the events are "OR'd" together. For example, if the override and tone trigger events are both enabled, the AUX contacts will activate when the override input "OR" the tone trigger input "OR" both of them become active. If all 4 events were enabled, the contacts would activate any time the UT11 was doing anything but sitting idle (this is the factory default condition).

### Event Driven/Priority Driven Mode

There are applications where the AUX relay contacts should activate regardless of what else may be going on in the UT11 (Event-Driven Mode) and other times when it should activate so long as there is not another higher priority input active (Priority-Driven Mode).

For example, an application requires that a strobe flash for as long as the night ring line rings. This is accomplished by selecting the Event-Driven Mode and disabling all the events except night ring. In this configuration, the AUX relay contacts will activate whenever the night ring line becomes active. This action is independent of whatever else may be going on in the UT11. Therefore, even though a page may be occurring that suppresses the night ring audio tone, the AUX relay will still cause the strobe to flash.

Likewise, there may be applications where it is desirable to have a higher priority event deactivate the AUX relay operation even though a lower priority event is still on going. For example, suppose the strobe above was specified to flash only when the night ring audio is produced. This is accomplished by selecting the Priority-Driven Mode instead of the Event-Driven Mode. In this case any other higher priority event will deactivate the AUX relay for the duration of that event. The AUX relay will become active again if the lower priority event is still active when the higher priority event finishes.

### Delay/No Delay

It is sometimes desirable for the AUX relay to activate immediately after an event rather than during an event. By selecting the Delay programming option, the contacts activate immediately after the enabled events occur. The contacts will activate for 1 second and then deactivate.

For example, a specification requires that after a tone has been produced an audio message is to be played that is triggered by a momentary contact closure. To accomplish this, the tone trigger event is enabled and the Delay option is selected. In this configuration the AUX relay contacts trigger the message playback device at the end of the tone.

What about the Event- or Priority-Driven setting? Only the override input is a higher priority setting than the tone trigger and thus could interrupt the tone. Setting it to Event-Driven Mode will cause the audio message to trigger at the end of the tone duration, even if the override is suppressing the tone itself. However, setting it to Priority-Driven Mode may lead to multiple pulses being produced since the UT11 will consider the tone trigger completed when the override suppresses it and will produce the pulse. If the tone is still in progress when the override is removed, then a second pulse will be produced at the actual end of the tone duration.

**Example 1**

	Enabled/ Disabled	Code
<b>Event</b>		
Override	Enabled	61
Tone Trigger	Enabled	63
Page	Disabled	64
Night Ring	Disabled	66
<b>Mode</b>		
Event	Enabled	71
Priority	Disabled	-
<b>Delay</b>		
Delay	Enabled	68
No Delay	Disabled	-

**Example 2**

	Enabled/ Disabled	Code
<b>Event</b>		
Override	Disabled	60
Tone Trigger	Disabled	62
Page	Disabled	64
Night Ring	Enabled	67
<b>Mode</b>		
Event	Enabled	71
Priority	Disabled	-
<b>Delay</b>		
Delay	Enabled	-
No Delay	Disabled	69

**Example 3**

	Enabled/ Disabled	Code
<b>Event</b>		
Override	Disabled	60
Tone Trigger	Enabled	63
Page	Disabled	64
Night Ring	Disabled	66
<b>Mode</b>		
Event	Enabled	71
Priority	Disabled	-
<b>Delay</b>		
Delay	Enabled	68
No Delay	Disabled	-

**Example 1: Emergency Tone/Emergency Announcement Bypass**

The tone trigger and override inputs are used to provide emergency tones and live emergency announcements and when this happens any local attenuators are to be bypassed to ensure that emergency announcements can be heard.

The AUX relay contacts will signal the attenuators to go into the bypass mode. Program the UT11 with the override and tone trigger events enabled and all other events disabled. In this case the UT11 can be in Event-Driven or Priority-Driven Mode since the application only involves the two highest priority inputs. Nevertheless, set the operation for Priority-Driven with the No Delay option since the AUX relay contacts need to activate during the event. Now, when either the tone trigger OR override input becomes active, the AUX relay will signal the attenuators to bypass. During normal paging or night ring, the attenuators still control the audio level of their associated speakers.

**Example 2: Strobes Flash to Announce Night Ring**

Strobes throughout a facility are to flash whenever a night line rings to provide a visual alert of the ringing line. An audible alert is optional.

Program the UT11 with the night ring event enabled and all other events disabled. Select the Event-Driven Mode since the strobes are to flash when the night ring line is ringing independent of whatever other events are taking place with the UT11. No Delay should be selected so that the AUX relay contacts activate during the event. The strobes will flash for as long as the night line rings. If a page, tone trigger or override page occurs during this event, the night ring tone will stop, but the strobe will continue to flash. The strobes stop only when the night line stops ringing.

**Example 3: Message Playback Following Tone**

A message is to be played immediately after a chime tone is produced.

In this application the tone trigger input will be activated to cause the chime tone (one of the UT11's selectable tones). After the tone finishes the AUX relay contacts will trigger an audio playback device with a 1-second contact closure pulse. Program the UT11 with the tone trigger event enabled and all other events disabled. Select the Event-Driven Mode (see below about using Priority-Driven Mode in this case). Select the Delay option so that the contact will pulse immediately after the event finishes. Now, whenever the tone trigger is activated a message will play immediately after the tone stops. Typically the audio gets into the paging system through the override input.

**Priority-Driven Mode Issues**

Using the Priority-Driven Mode can cause some unexpected results. When the event selected to control the AUX relay is interrupted by a higher priority event that is not enabled, the UT11 will consider that the AUX relay event has finished even if it hasn't, and the relay will change states. If the Delay option is selected, then the UT11 will pulse the AUX relay contacts. If the AUX relay event is still active after the high priority event is completed, the AUX relay will again activate. This operation can lead to multiple changes in the relay state (when No Delay is selected) or multiple pulsations of the AUX relay (if the Delay option is selected). Care should be taken in using the Priority-Driven Mode, especially when low priority events are enabled.



# Feature Codes & Defaults

	Feature	Feature Code	Data	Default
<b>Pre-Announce / Confirmation Tone</b>	Handset & Outputs Destination	Handset only	01	01
		Handset only	02	
		Outputs only	03	
	Tone	Inhibit	04	05
		Beep	05	
		Chime	06	
<b>Override Tone</b>	Disable	08		08
	Enable	09		
<b>Trunk Disconnect</b>	Disable	14		15
	Enable	15		
<b>Tone Trigger</b>	Slow Whoop Follow Contact	20		23
	Tone Follow Contact	21		
	2 Sec Burst	22		
	3 Sec Burst	23		
	4 Sec Burst	24		
	5 Sec Burst	25		
	6 Sec Burst	26		
	7 Sec Burst	27		
	Double Chime	28		
	Double Chime Follow Contact	29		
<b>Night Ring</b>	Simulated Ring	31		31
	Chime	32		
<b>DTMF Block</b>	Disabled	40		41
	Enabled	41		
<b>Timers</b>	Default Timer	50	00 - 99	03
	VOX Timer	51	0 - 9	6
<b>Aux Relay Response</b>	Override Disabled	60		61
	Override Enabled	61		
	Tone Trigger Disabled	62		63
	Tone Trigger Enabled	63		
	Page Disabled	64		65
	Page Enabled	65		
	Night Ring Disabled	66		67
	Night Ring Enabled	67		
	Delay	68		69
	No Delay	69		
Priority-Driven	70	71		
Event-Driven	71			
<b>Setup Tone</b>	Turn On	00		
	Turn Off	Hang Up		
<b>Reset</b>	Reset Default	99		

## Notes to Feature Codes

Note 1 - The data digits represent time in 10's of seconds, i.e. "01" = 10 seconds. Entering "00" will disable the timer.

Note 2 - This single data digit indicates VOX delay time in seconds. Entering "0" will disable the timer.

# Specifications

---

Input Impedance:	600 ohms
Input Level:	-10 dBm nominal
VOX Sensitivity:	-30 dBm
Music Source Input Impedance:	8 to 600 ohms
Music Input Level:	-10 dBm
Output Impedance:	8 ohms
Output Level:	-10 dBm nominal
Contact Closure:	2A @ 30V DC 0.6A @ 125V AC
DC Output:	1A @ 24V DC
Voltage:	120V AC
Current:	0.5A
Temperature:	0 to 104° F
Humidity:	0 to 85% non-precipitating
Dimensions/Weight:	12 <sup>3</sup> / <sub>16</sub> " W x 5 <sup>1</sup> / <sub>4</sub> " H x 2 <sup>1</sup> / <sub>2</sub> " D
Weight:	5 lb.

# Block Diagram

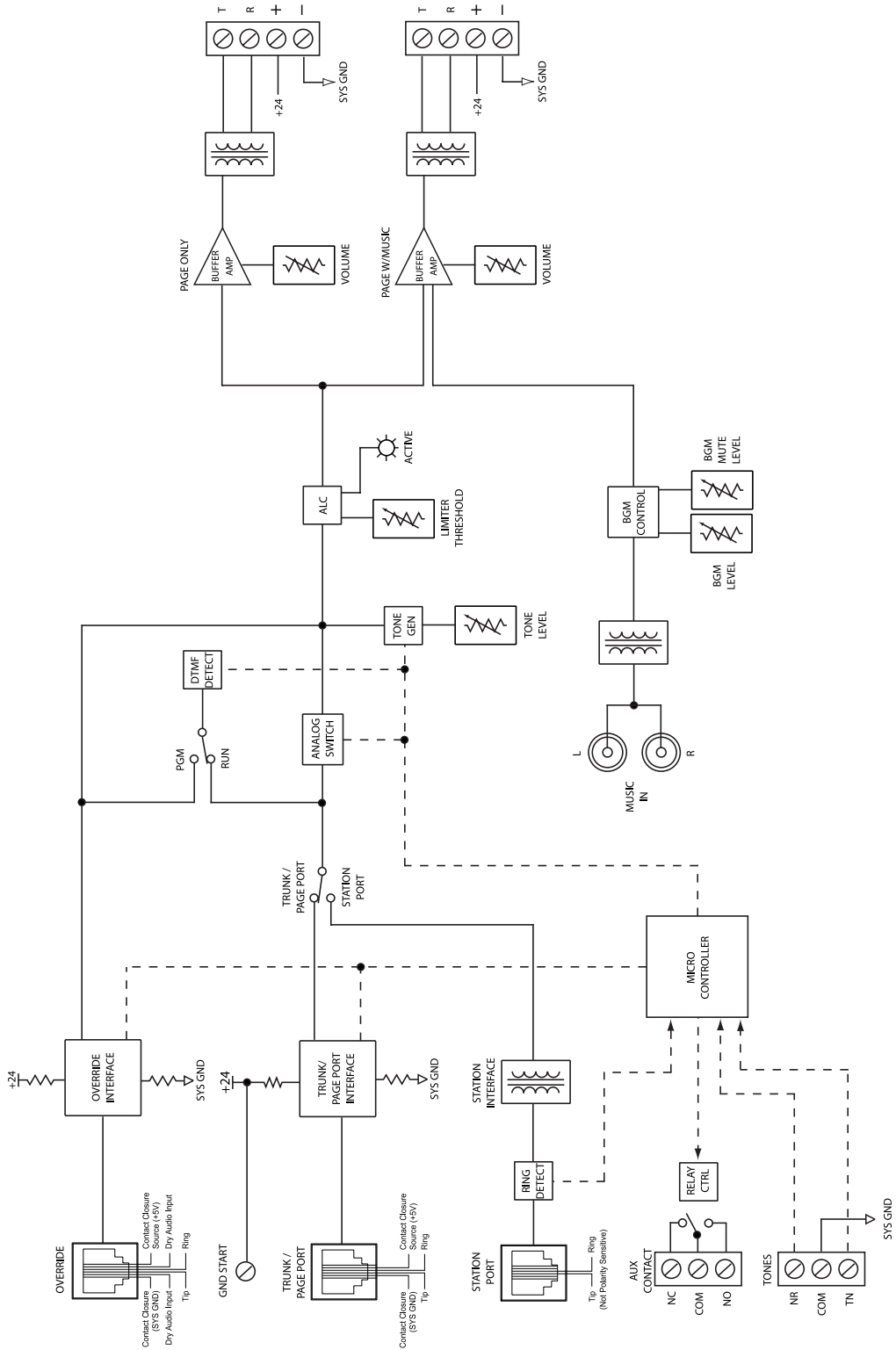

# Limited Warranty

---

The UT11 is warranted to be free from defects in material or workmanship for two (2) years from the date of sale to the original purchaser. Any part of the product covered by this warranty that, with normal installation and use, becomes defective will be repaired or replaced by Bogen, at our option, provided the product is shipped insured and prepaid to: Bogen Factory Service Department, 50 Spring Street, Ramsey, NJ 07446, USA. The product will be returned to you freight prepaid. This warranty does not extend to any of our products that have been subjected to abuse, misuse, improper storage, neglect, accident, improper installation or have been modified or repaired or altered in any manner whatsoever, or where the serial number or date code has been removed or defaced.

**THE FOREGOING LIMITED WARRANTY IS BOGEN'S SOLE AND EXCLUSIVE WARRANTY AND THE PURCHASER'S SOLE AND EXCLUSIVE REMEDY. BOGEN MAKES NO OTHER WARRANTIES OF ANY KIND, EITHER EXPRESS OR IMPLIED, AND ALL IMPLIED WARRANTIES OF MERCHANTABILITY OR FITNESS FOR A PARTICULAR PURPOSE ARE HEREBY DISCLAIMED AND EXCLUDED TO THE MAXIMUM EXTENT ALLOWABLE BY LAW.** Bogen's liability arising out of the manufacture, sale or supplying of products or their use or disposition, whether based upon warranty, contract, tort or otherwise, shall be limited to the price of the product. In no event shall Bogen be liable for special, incidental or consequential damages (including, but not limited to, loss of profits, loss of data or loss of use damages) arising out of the manufacture, sale or supplying of products, even if Bogen has been advised of the possibility of such damages or losses. Some States do not allow the exclusion or limitation of incidental or consequential damages, so the above limitation or exclusion may not apply to you. This warranty gives you specific legal rights, and you may also have other rights which vary from State to State.

Products that are out of warranty will also be repaired by the Bogen Factory Service Department -- same address as above or call 201-934-8500. The parts and labor involved in these repairs are warranted for 90 days when repaired by the Bogen Factory Service Department. All shipping charges in addition to parts and labor charges will be at the owner's expense. All returns require a Return Authorization number.

**BOGEN<sup>®</sup>**  
**COMMUNICATIONS, INC.**

50 Spring Street, Ramsey, NJ 07446, U.S.A.  
Tel. 201-934-8500, Fax: 201-934-9832, [www.bogen.com](http://www.bogen.com)

## Free Manuals Download Website

<http://myh66.com>

<http://usermanuals.us>

<http://www.somanuals.com>

<http://www.4manuals.cc>

<http://www.manual-lib.com>

<http://www.404manual.com>

<http://www.luxmanual.com>

<http://aubethermostatmanual.com>

Golf course search by state

<http://golfingnear.com>

Email search by domain

<http://emailbydomain.com>

Auto manuals search

<http://auto.somanuals.com>

TV manuals search

<http://tv.somanuals.com>