

Bolens®

Owner/Operator Manual

Snowthrowers

- **Safety**
- **Assembly**
- **Controls**
- **Operation**
- **Maintenance**

Models

824A
24", 8 HP

1026
26", 10 HP

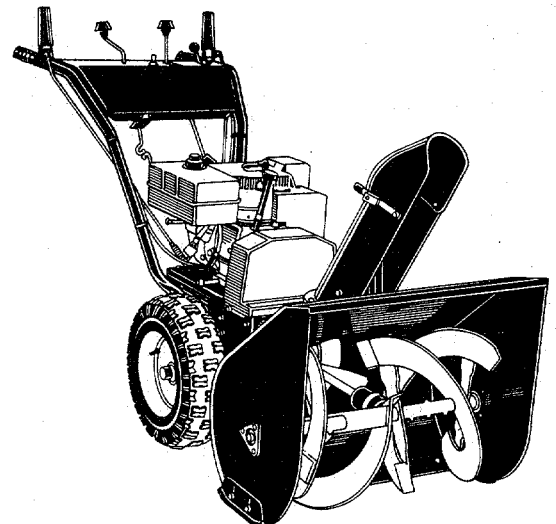

Thank you for purchasing this product. We believe you now own one of the finest snowthrowers available.

This is a safety, operation and general maintenance manual which does not attempt to cover major repairs.

All information in this manual is based on the latest product information available at the time of printing.

This manual is considered a permanent part of this unit and must stay with the unit if resold. A replacement manual can be obtained from the factory, free of charge.

Our equipment is carefully designed, engineered and manufactured for excellent performance if properly operated and maintained. Read this manual to learn

about your unit, its features and operation. Review this manual each season to refamiliarize yourself with using and caring for your snowthrower.

Our products have passed the rigid safety standards set by the Outdoor Power Equipment Institute and an independent testing laboratory.

The snowthrower's warranty statement is included on the back cover of this manual. Carefully read and understand the warranty, its requirements and limitations. Also, please complete and return the postpaid owner registration card included with this manual to register each unit and keep the owner informed with important product bulletins and safety literature.

Table of Contents

Service Information	3	SECTION 5	
Identification Numbers	3	Operation	11
SECTION 1		Pre-Start Checklist	11
Safety	4	Filling Fuel Tank	11
Training	4	Starting	12
Preparation	4	Testing Auger and Wheel Drive	12
Operation	4	Stopping	12
Maintenance and Storage	5	Changing Gears	12
Decals	5	Snowthrowing Tips	13
SECTION 2		Snowthrowing Patterns	14
Attachments & Kits	6	SECTION 6	
SECTION 3		Maintenance	15
Assembly	6	Checking and Adding Oil	15
SECTION 4		Changing Oil	15
Controls	9	Spark Plug	15
Auger Drive Control Lever	9	Lubrication	16
Wheel Drive Control Lever	9	Wheel Drive Belt Adjustment	16
Gear Shift Lever	9	Wheel Drive Belt Replacement	17
Discharge Chute Crank & Cap	9	Auger Drive Belt Adjustment	17
Engine Ignition Keyswitch	10	Auger Drive Belt Replacement	18
Throttle	10	Slip Differential Adjustment	18
Skid Shoes	10	Drive Disc Clearance Adjustment	18
Scraper Blade	10	Maintenance Chart	20
Engine Choke Knob	10	Storage	20
Pre-Start Primer Button	10	Troubleshooting	21
Engine Recoil Starter	10	Specifications	24
Fuel Shutoff Valve	10	Warranty	Outside Back Cover

Unit Service and Repair

To service your unit, contact a factory-authorized dealer. Provide the dealer with the unit's model/serial number and the part's description. Do not return parts directly to the factory.

Warranty Service

The warranty for this unit is printed on the back cover of this manual.

Left and Right Sides

Left and right sides are determined from the operator's position, facing the direction of forward travel.

Engine Service

For engine service, contact an authorized engine dealer. To locate an authorized engine dealer, refer to the "Yellow Pages" under "Engines—Gasoline" or "Gasoline — Engines". Provide the dealer with the engine model and serial numbers.

Identification Numbers

For prompt service, provide the authorized dealer with the identification numbers of your unit. Fill in the spaces below with the identification numbers for future reference.

Date of Purchase:

Unit Serial Number:

Engine Model/Serial Numbers:

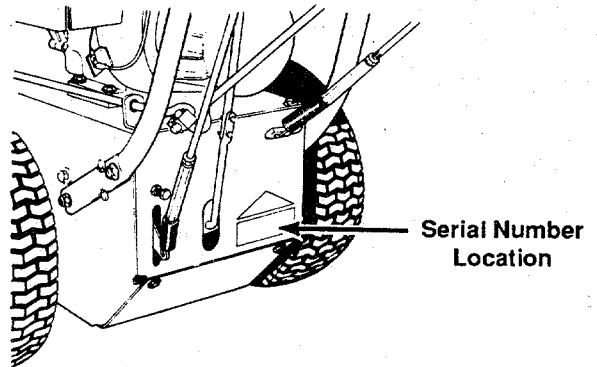

Warning to all operators in California and other applicable states



Under California law, and under the laws of several other states, it is not lawful to operate an internal combustion engine using hydrocarbon fuels on any forest covered, brush covered, or grass covered land, or on land covered with grain, hay, or other flammable agricultural crop, without an engine spark arrester in continuous effective working order.

The engine on this unit, like most outdoor power equipment, is an internal combustion engine that burns gasoline, a hydrocarbon fuel. Therefore, this unit must be equipped with a spark arrester muffler in continuous effective working order. Contact your authorized dealer for information about obtaining a spark arrester. The spark arrester must be attached to the engine exhaust system in such a manner that flames or heat from the system will not ignite flammable material. Failure of the owner/operator of this unit to comply with this regulation is a misdemeanor under California law, and may also be a violation of other state and/or federal regulations, laws, ordinances, or codes. Contact the local fire marshal or forest service for specific information about which regulations apply in your area.

Safety

Important!

Safe Operating Practices For This Snowthrower



The triangle with an exclamation mark inside is a safety alert symbol. The safety alert symbol is used in this manual and on the snowthrower's decals to alert you to potential hazards. Whenever you see this symbol, read and obey the safety message that follows it. Failure to obey the safety message could result in death, personal injury, property destruction or damage.

Preventing accidents is the responsibility of every equipment operator. The operator is responsible for hazards and/or accidents occurring to people or property. The following general safety precautions must be fully understood and adhered to when operating this snowthrower. Although these safety precautions are thorough, they can not be all-inclusive and do not take the place of common sense. Review these safety precautions frequently and never take chances. Be careful before, during and immediately after use of any powered equipment. Accidents can be prevented.

Training

1. Very carefully read this manual, the engine manual and all literature received with unit. Understand safe operation of unit. Thoroughly know all controls and how to stop unit and disengage controls quickly in event of emergency.
2. Never allow children or untrained or irresponsible adults to operate unit.
3. Keep area of operation clear of all people, particularly small children and pets.

Preparation

1. Thoroughly inspect snowthrowing area. Clear area of all objects (doormats, sleds, rocks, branches, wires, etc.).
2. Disengage all clutches before starting engine.
3. Wear adequate winter clothing and footwear that will improve traction on slippery surfaces.
4. Adjust the collector housing height to clear gravel or crushed rock surfaces.

5. Never make adjustments with unit running unless otherwise specified in this manual.
6. Let engine and snowthrower adjust to outdoor temperatures before clearing snow.
7. Always wear eye protection during operation or while performing adjustment or repair.
8. Check engine oil level before starting.
9. Handle gasoline with care. Gasoline is highly flammable and its vapors are explosive. Check gas level in tank before starting engine. DO NOT fill gas tank indoors or with engine running or hot. Allow engine to cool for several minutes before filling tank.
10. Use an approved fuel container. Use a funnel or spout to help prevent spills. After filling, securely reinstall gas tank and fuel container caps. Wipe up spilled gasoline before starting the engine.

11. Do not fill gas tank completely. Fill tank only to within 1/2-inch of bottom of filler neck to allow for expansion.
12. Keep smoking materials, sparks and flames away from gas tank and fuel container.
13. DO NOT operate unit without guards and safety devices in place. DO NOT attempt to defeat the purpose of any safety device.
14. Before starting engine, check unit for loose or missing fasteners (nuts, screws, bolts, etc.).
15. Before starting engine, auger and discharge chute must be free of ice.

16. Follow instructions provided with optional battery charger and electric start kits and:

- A. Use a three-pronged, outdoor-rated and approved electrical cord and outlet. Do not use a damaged cord.
- B. When connecting or disconnecting cord, stand on dry ground. Do not stand in puddles or on wet or damp ground. Hands or gloves must be dry. Do not use electric starter during rainy weather.
- C. When connecting cord, first connect cord to engine terminal, then to properly grounded 110V outlet.

D. Do not abuse cord or yank to disconnect. Never pull unit with cord. Keep cord away from oil, sharp edges and excessive heat.

Operation

1. Before each use, check operation of controls. Do not operate unit unless all controls are functioning properly.
2. Do not put hands or feet near or under rotating parts. Always keep clear of intake and discharge openings.
3. Exercise extreme caution when operating near or crossing gravel drives, walkways or roadways. Stay alert for and avoid hazards and traffic.
4. After striking an object, stop engine, disconnect spark plug wire and prevent it from touching spark plug. Remove key from keyswitch. Carefully check for and repair damage before restarting and operating unit.

5. If unit should vibrate abnormally, stop engine, disconnect spark plug wire and prevent it from touching spark plug. Remove key from keyswitch. Carefully check for cause of vibration. Repair damage before restarting and operating unit.
6. Before clearing, repairing, or inspecting unit or unclogging auger/impeller housing or discharge chute, **stop engine and allow all moving parts to stop.** Disconnect spark plug wire and prevent it from touching spark plug. Remove key from keyswitch.
7. Do not run engine indoors. Exhaust fumes contain carbon monoxide, a deadly poison that is colorless, odorless and tasteless.
8. Do not clear snow across the face of slopes or hills. Be extremely cautious when changing direction on slopes or hills. Do not attempt to clear snow on slopes or hills with more than a 10° incline.
9. Never operate unit without proper guards, plates and other safety/protective devices in place.
10. Never operate unit near buildings, glass enclosures, automobiles, window wells, drop-offs, etc. without proper adjustment of snow discharge angle and direction. Keep children and pets safely away from unit and out of discharge range.
11. Do not overload unit's capacity by attempting to clear snow too fast.
12. Never operate unit at high transport speeds on slippery surfaces.
13. Avoid throwing snow while backing. If running unit in reverse becomes necessary, look in the direction you are moving and proceed with caution. If you have to pull unit rearward, release both drive control levers. Always check behind you for hazards.
14. Never direct discharge toward bystanders. Never allow anyone in front of unit while it is running.
15. Disengage power to auger when transporting or not using unit.
16. Use only attachments and accessories recommended by Bolens Corporation.
17. Never operate unit in poor visibility or inadequate light.
18. Always be sure of your footing to help avoid falling. Grasp handles firmly. Walk, do not run, while operating unit.
19. **NEVER** use hands or feet to remove snow from clogged auger/impeller or discharge chute. Stop engine, disconnect spark plug wire and prevent it from touching spark plug. Remove spark plug to help prevent engine compression from causing movement. Remove key from keyswitch. Use a long stick (at least three feet long) to unplug the snow.
20. Do not alter engine governor setting or overspeed engine.
21. Stop both wheel drive and auger drive when any child, inattentive person or animal approaches.
22. Do not touch engine parts which may be hot from operation. Allow engine to cool before inspecting, cleaning or repairing unit.
23. Do not operate unit while under the influence of alcohol or drugs.
24. Never carry children, people or animals on unit. They could fall off and be seriously injured, or interfere with safe operation of unit.
25. Proceed with extra caution when operating near corners, shrubs, trees and objects which can obscure vision.
26. Keep children out of operating area and under supervision of a responsible adult other than person operating the unit. Children or others may appear at any time, so be prepared to stop suddenly and avoid them. Never assume children will remain where last seen.
27. Do not use unit near drop-offs, ditches or embankments. If a wheel should go over an edge, or if an edge caves in, unit could fall or suddenly overturn.
28. Do not wear long, loose clothing or hair that could get caught in rotating parts.
29. Exercise extreme caution to avoid slipping or falling, especially while operating in reverse.

Maintenance and Storage

1. Never perform maintenance with engine running or when spark plug wire is connected to spark plug.
2. Before season and every eight hours of operation, check unit for loose or missing fasteners (nuts, screws, bolts, etc.). Check shear bolts and other fasteners at frequent intervals for proper tightness to help ensure unit is in safe working condition.
3. Never store unit with gas in gas tank inside a building where fumes may reach an open flame or spark. Allow engine to cool before storing unit in any enclosure.
4. Refer to "Storage" if storing unit longer than three months.
5. Maintain or replace safety and instructional labels as necessary. See enclosed Parts Catalog for location of replaceable labels.
6. Continue running unit for a few minutes after throwing snow to help prevent auger from freezing up. After stopping the engine, brush snow off unit.
7. Use only genuine Bolens replacement parts. Replacement parts manufactured by others could present safety hazards even though they may fit on this snowthrower.
8. Store gasoline in a cool, well-ventilated area, safely away from sparks or flame-producing equipment. Store gasoline in an approved container, safely out of the reach of children.

Decals

1. For your personal safety and the safety of others, safety message decals are affixed to your snowthrower. Keep these decals clean and legible at all times. Contact your local factory-authorized servicing dealer or Bolens Corporation at the address listed on the back cover of this manual if any of these decals is missing or becomes illegible.
2. Refer to the Snowthrower Parts Catalog for decal locations, part(s) number(s) and ordering instructions.

Section 2

Attachments & Kits

Below is a list of attachments and kits available for your snowthrower. The information is the most current at the time this manual was printed. Check with your local factory-authorized Bolens dealer for more recent information.

Number	Description	Number	Description
42501	Blizzard Pack	6857	Starter Kit—110 Volt
42500	Cab Kit	N/A	Drift Slicers— Order two (2) 1715427 drift slicer blades, four (4) 1100044 hex head cap screws and four (4) 1732499 lock nuts.
1745785	Light Kit Assembly		
6918.	Tire Chains		

Section 3

Assembly

Handlebars

Secure handlebars to chassis with four 3/8-16 x 3/4 bolts (A, Fig. 3-1).

Install Throttle Lever

1. Insert throttle lever (X, Fig. 3-2) up through slot in left-hand side of control panel. Secure with #10–24 x 5/8 screws and #10 external lockwasher nuts (C). Screws must pass through holes in throttle base plate.
2. Place throttle lever knob (B, Fig. 3-1) in 200° F water for 30 minutes. Tap knob onto upper end of throttle lever.

Discharge Chute Assembly

1. Remove both side sets of shims and clips (F and G, Fig. 3-1 inset). Loosen but do not remove front shim and clip. Apply multi-purpose grease on surface of discharge chute flange (P).
2. Reinstall discharge chute. Hook front clip over deflector chute flange. Position shims above clips between chute and chute flange. Resecure all clips.

3. Install worm gear support bracket (L). Teeth in worm gear must mesh with teeth in base of discharge chute assembly. Insert bolt (K) through hole in worm gear support bracket (L) and mounting tab on unit. Install and tighten nut on bolt (K).

4. Attach control rod sections (H, I, J):

A. Insert end of upper chute control rod (I, Fig. 3-1 inset) as shown into nylon swivel block (D) on end of middle chute control rod (H).

B. Insert a cotter pin through hole in upper section (I) of chute control rod. Bend cotter pin so it remains in hole. Repeat steps A and B for lower end of control rod middle section (H).

5. Rotate chute control crank (M, Fig. 3-1) at handlebar console. Deflector chute should turn without binding. Readjust bracket (L) and locknut (R) as necessary.

Auger Drive Control Rod

One end of auger drive control rod is already attached to auger drive handlebar control lever (N, Fig. 3-1).

1. Hook spring (O, Fig. 3-3) on lower end of auger drive control rod into hole in control arm (X). Press arm (X) down fully.
2. Measure and note spring (O) length, then fully depress auger drive control lever on right-hand handlebar. Spring should now be 11/16" +/- 1/16" (17 mm +/- 1.5 mm) longer than earlier measurement. To adjust:

A. Loosen jam nut (XX) and thread upward on rod. Turn adjuster (YY) to increase or decrease length as needed.

NOTE: 1-1/4 turns of adjuster equals 1/16" (1.5 mm) of spring extension.

Wheel Drive Control Rod

One end of wheel drive control rod is already attached to wheel drive handlebar control lever (Q, Fig. 3-1).

1. Hook spring (OO, Fig. 3-3) on lower end of control rod into hole in control arm (Z). Press control arm (Z) down fully.
2. Measure and note spring (OO, Fig. 3-3) length. Fully depress wheel drive control lever on left-hand handlebar.

ATTENTION: OWNERS OF BOLENS® 8 AND 10 HP SNOWTHROWERS

**SUPPLEMENT TO THE SAFETY AND OPERATION INSTRUCTIONS MANUAL
FOR BOLENS® LARGE FRAME SNOWTHROWERS
MODELS 624, 824, 824A, 1026 AND 1032**

(This information is in addition to information in your Owners Manual, Form 4210-2).

Keep this sheet with your owners manual. Please insert between Pages 6 and 7.

PRE-OPERATIONAL CHECK

Before starting the engine on your BOLENS® snowthrower, please operate the auger and wheel drive levers to make sure they release freely (return to neutral).

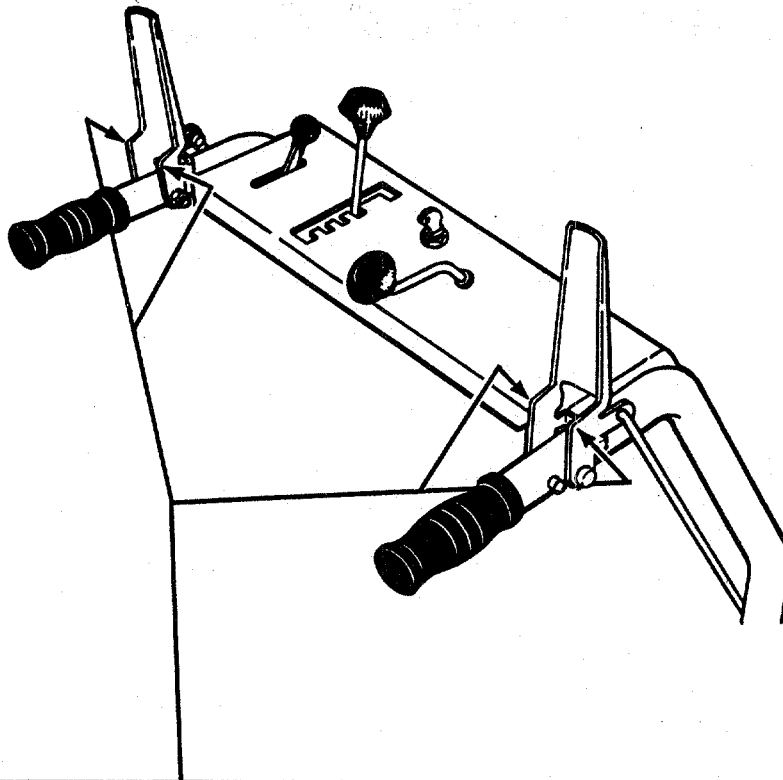

If levers do not operate freely, spread lower portion of both levers outward to provide clearance of 1/16" between the lever and handle (see illustration). Levers can be spread apart with an adjustable wrench or pliers.

IMPORTANT PRODUCT NOTICE

Spring should now be approximately $1\frac{1}{16}'' \pm 1/16''$ (17 mm \pm 1.5 mm) longer. If not:

A. Loosen jam nut (JJ) and thread upward on rod. Turn adjuster (SS) to increase or decrease length as needed.

NOTE: 1-1/4 turns of adjuster equals 1/16" (1.5 mm) of spring extension.

B. Tighten jam nut (JJ) against adjuster (SS).

NOTE: DO NOT over-tighten hardware. Lever must move freely.

4. While holding gear shift lower rod down, thread pivot block (Z, Fig. 3-2) so it fits into hole in gear shift lever upper section (U).

5. Reinstall pivot block (Z) in gear shift control lever hole and secure with flat washer and hairpin cotter. Tighten jam nut against pivot block.

6. Move gear shift control lever (W, Fig. 3-1) through full range of travel and check for binding, interference, etc.

7. Perform Drive Disc Clearance Adjustment. See page 18.

Gear Shift Rods

1. Attach gear shift lever upper section (U, Fig. 3-2) and lower section (Z) together.

1. Attach gear shift upper rod (U, Fig. 3-3) and lower rod (Y) together with 1/4-20 x 3/4 hex screws and 1/4-20 locknuts.

2. Move gear shift lever (W, Fig. 3-1) to fifth gear. Remove hairpin cotter and flat washer from pivot block (Z, Fig. 3-2). Disconnect pivot block from gear shift lever.

3. Push gear shift lower rod (Y, Fig. 3-3) downward as far as possible.

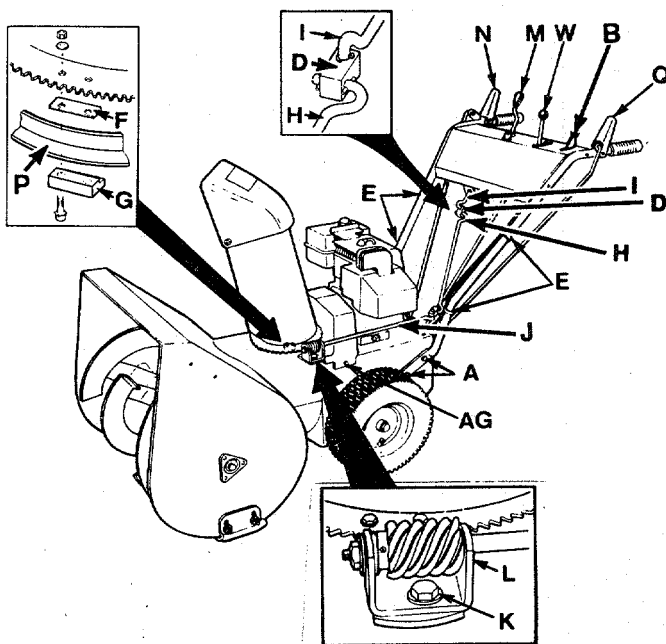

Fig. 3-1

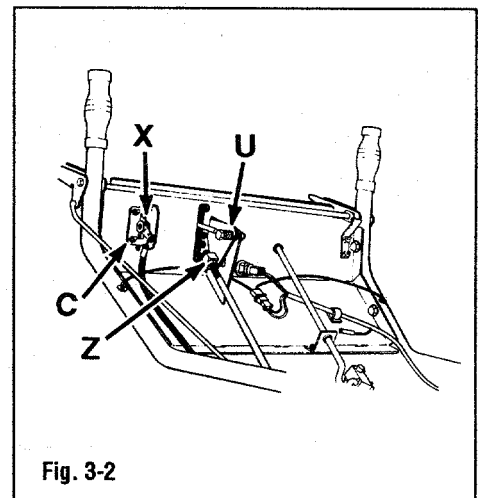

Fig. 3-2

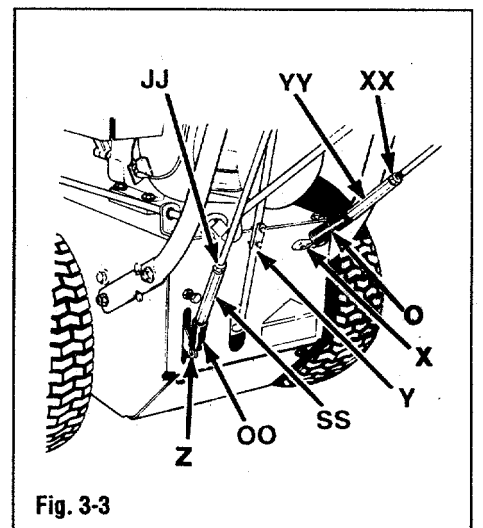

Fig. 3-3

Assembly (continued)

Wiring Harness Installation

1. Connect lead wire (AB, Fig. 3-4) to engine wiring harness connector. Plug lead wire into connector receptacle containing yellow wire (AC).
2. Connect eye terminal to screw (AD) on engine shroud. Plug connector (AE) into engine plug.
3. Secure wires to handlebars with tie straps (E, Fig. 3-5).

Brake Arm Adjustment

1. Remove bolts securing belt cover (AG, Fig. 3-5). Lift belt cover (C) up and off unit.
2. Check brake arm adjustment:
 - A. Fully depress and hold auger drive handlebar control lever (N). A second person may need to hold handle down.
 - B. Look down through pulleys and belts at front of engine (A, Fig. 3-6). Check gap between brake arm (AH, Fig. 3-7) and belt (AL). Gap should measure between 1/16" and 1/8" (1.5–3 mm).

- C. To adjust gap, loosen nut (AI). Hold set screw (AK) in place with an allen wrench and turn nut (AJ) until proper clearance is obtained. Retighten nut (AI).
3. Reinstall belt cover.

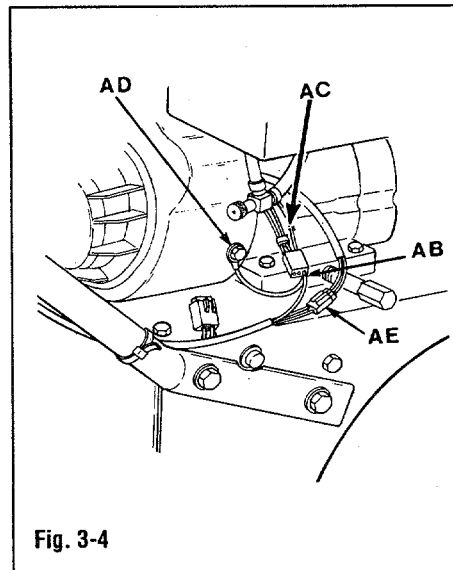

Engine Oil



Engine is shipped WITHOUT oil. DO NOT start engine before adding correct type and amount of engine oil. See engine owner's manual.

1. Unscrew oil fill cap (AM, Fig. 3-8) and place aside. Insert a clean funnel into oil filler tube (AL).
2. Slowly pour oil of the correct type (see engine owner's manual) through funnel and into oil filler tube. Engine holds approximately 26 ounces. Fill to FULL mark on dipstick.

NOTE: DO NOT overfill. While adding oil to engine, frequently stop and check oil level.

Tire Pressure

1. Check tire inflation pressure.
2. To help prevent pulling to one side, inflate both tires evenly (8 to 12 psi).

Auger Gear Case Oil

Check auger gear case oil level. See "Lubrication" on page 16 for instructions.

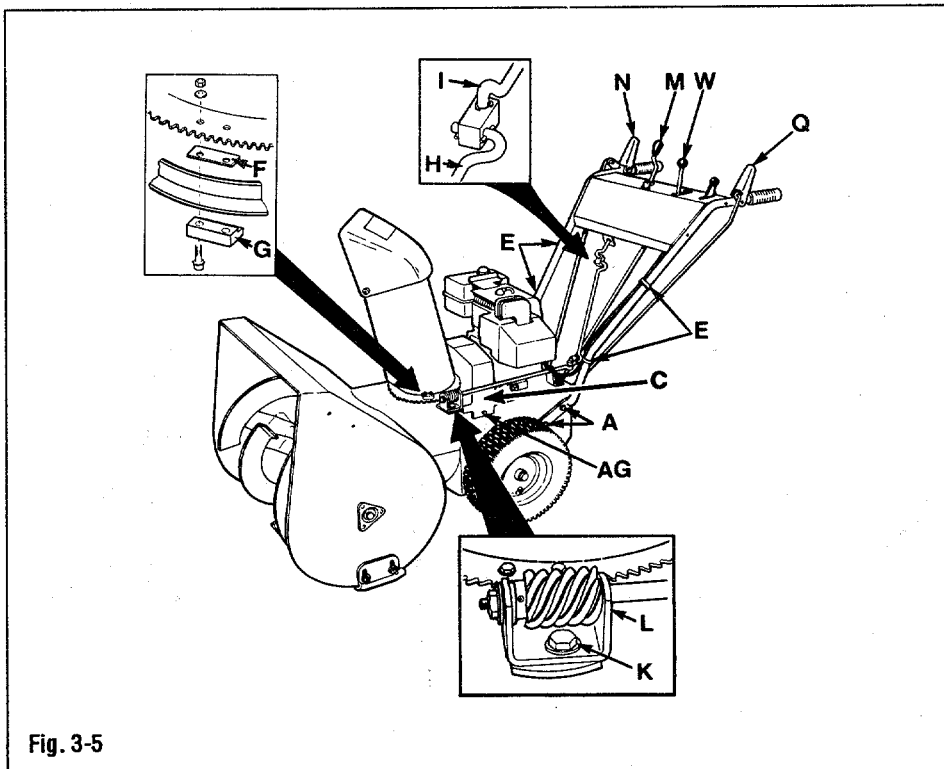

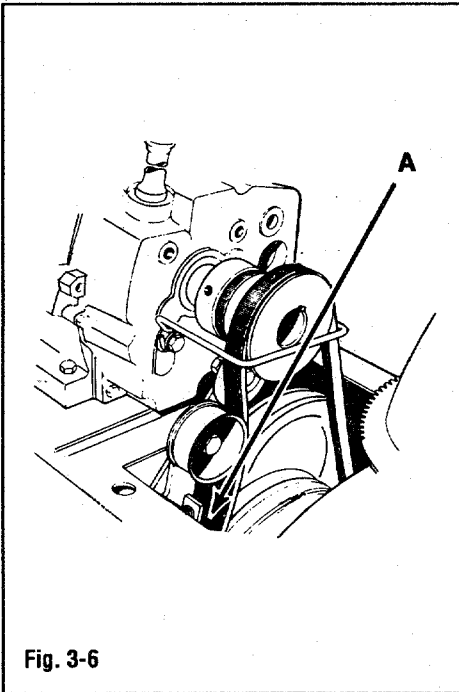

Fig. 3-6

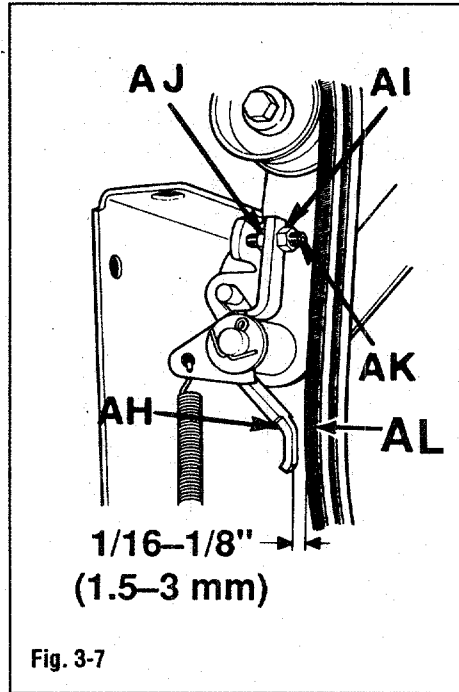

Fig. 3-7

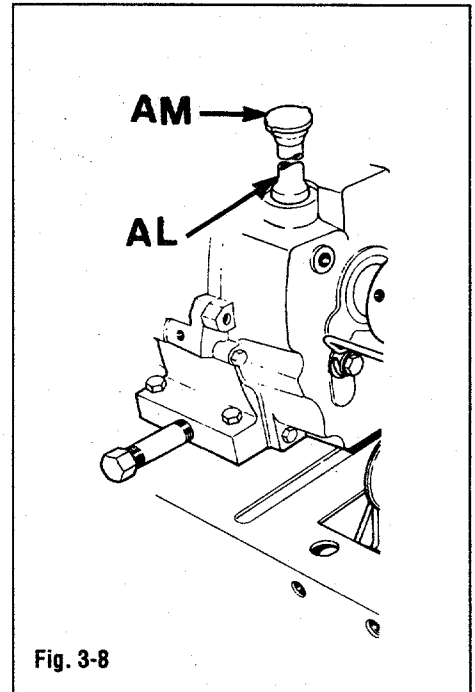

Fig. 3-8

Section 4

Controls

Wheel Drive Control Lever

Wheel drive control lever (C, Fig. 4-1) is located on top of left-hand handlebar tube in front of hand grip. Push down to engage wheel drive. Release to disengage.

Auger Drive Control Lever

Auger drive control lever (A, Fig. 4-1) is located on top of right-hand handlebar tube in front of hand grip. Push down to engage auger (auger will rotate). Release lever to disengage.

Gear Shift Lever

Located just left of center on control panel (D, Fig. 4-1). Use to select one of five forward gears or one of two reverse gears.

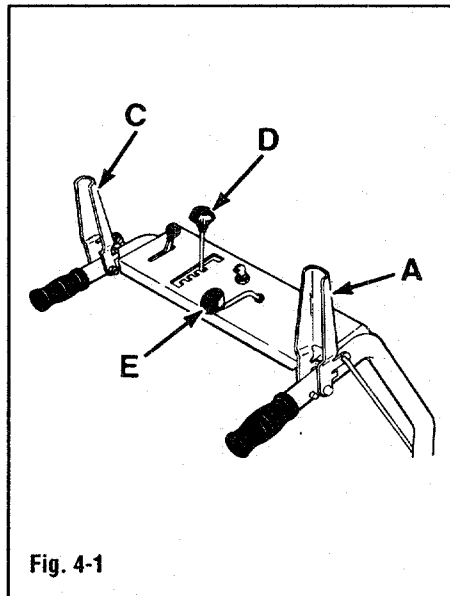

Fig. 4-1

Gear shift lever does not control auger speed. Select a gear by moving lever left, then forward or rearward. Align lever with notch for desired gear. While operating unit, release wheel drive control lever and come to a complete stop if moving. Select desired notch and re-engage wheel drive control lever.

When familiarizing yourself with gears or when operating near obstacles, use lower gears (first or second gear).

Discharge Chute Crank & Cap

Located slightly to right at center of control panel (E, Fig. 4-1). Turning discharge chute control crank clockwise turns discharge chute left. Approximately 10 turns of crank are required to move discharge chute from full left to full right.

Controls (continued)

Discharge snow in the same direction the wind is blowing (as long as it is safe to do so). As you change directions while throwing snow, reposition discharge chute so snow is discharged in the same direction the wind is blowing (see "Snowthrowing Patterns", page 14).

Discharge chute deflector cap (F, Fig. 4-3) is located at top of discharge chute and directs angle of snow discharge.

Adjust discharge angle by moving lever (G) outward, moving cap up or down as required and then releasing lever. During usual snowthrowing operations, especially during windy conditions, keep angle of discharge low. Always operate unit with chute guard (D) installed.

Engine Ignition Keyswitch

Keyswitch (D, Fig. 4-2) is located at front edge of control panel, just left of center. Keyswitch has two positions: RUN and OFF. Turn key to RUN before starting unit. Turn to OFF to stop.

Always remove ignition key when storing, cleaning or performing any maintenance on the snowthrower. Store in a safe place out of reach of children.

Throttle

Located on left-hand side of control panel, throttle (B, Fig. 4-2) alters engine speed.

For best performance, always operate engine at FULL speed.

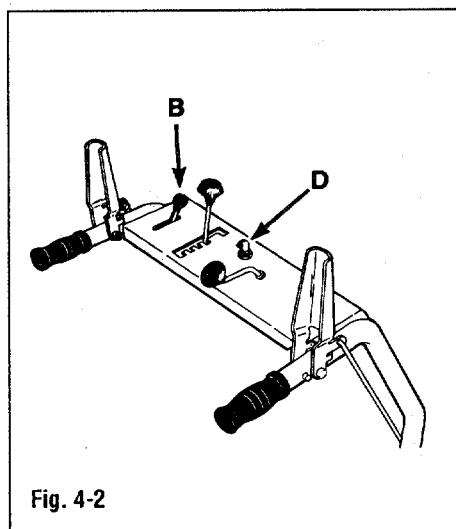

Fig. 4-2

Skid Shoes

Skid shoes (H, Fig. 4-5) are located at bottom sides of auger housing. Skid shoes adjust housing height. A lower auger housing makes a cleaner path when throwing snow off smooth surfaces. When operating across clear, level ground, adjust skid shoes so scraper blade clears ground by approximately 1/8" (3 mm).

Before operating on rough surfaces such as gravel-covered roadways, adjust skid shoes so the scraper blade travels above gravel and doesn't collect or throw it.

Before operating on a gravel-covered area, adjust skid shoes as follows:

1. Place unit on level surface, shut engine OFF. Allow all moving parts to come to a complete stop. Disconnect spark plug wire and prevent it from touching spark plug.
2. Loosen bolts securing skid shoes to auger housing sides. Move skid shoes as necessary to obtain desired gap between scraper blade and ground. Adjust skid shoes evenly or a sloping path will result.

Scraper Blade

Located at lower rear of auger housing, scraper blade (I, Fig. 4-5) is adjustable. Loosen nuts attaching blade to housing and adjust blade as required.

Blade may wear. Inspect before operating unit. Check for wear or damage and service as necessary.

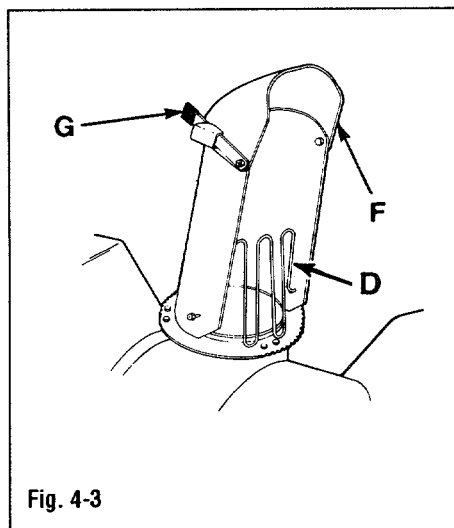

Fig. 4-3

Engine Choke Knob

Engine choke knob (L, Fig. 4-6) is located at engine rear on left-hand side of carburetor heat box.

Before starting cold engine, rotate choke knob clockwise to FULL CHOKE position. After engine starts and runs, gradually rotate knob counterclockwise to CHOKE OFF position.

A warm engine may require little or no choking.

Pre-Start Primer Button

Pre-start primer button (M, Fig. 4-6) is located at engine rear on upper left-hand side. Pressing button pumps a small amount of gasoline into engine to improve cold starting.

NOTE: When pressing pre-start primer button, cover small hole in button center with one finger.

Engine Recoil Starter

Located at engine rear, engine recoil starter is used to "pull-start" engine.



Before using recoil starter, make sure there are no obstacles behind you. Slowly pull black plastic handle until you feel resistance, then rapidly and vigorously pull handle. Maintain control of rope so it slowly returns into starter mechanism. Repeat pulling actions until engine starts.

Fuel Shutoff Valve

Located beneath gas tank, fuel shutoff valve (Fig. 4-4) controls fuel flow to carburetor.

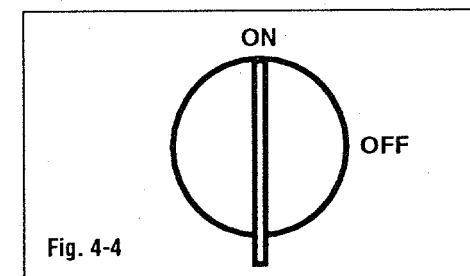

Fig. 4-4

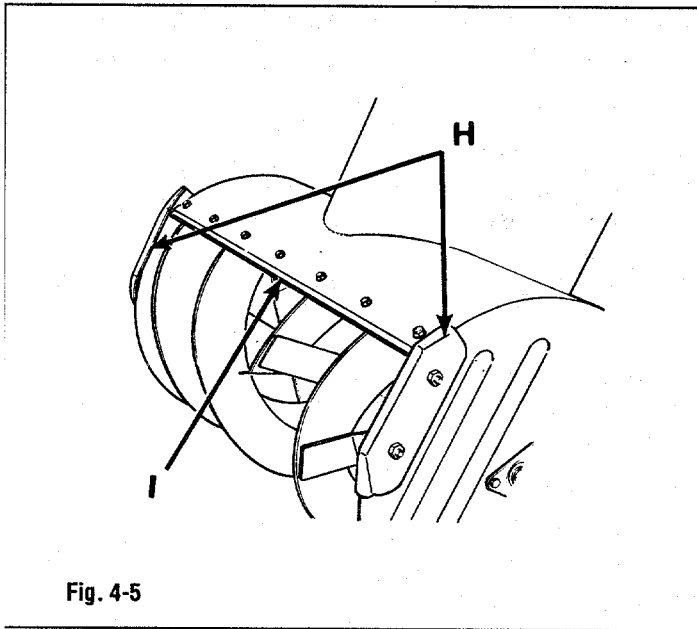

Fig. 4-5

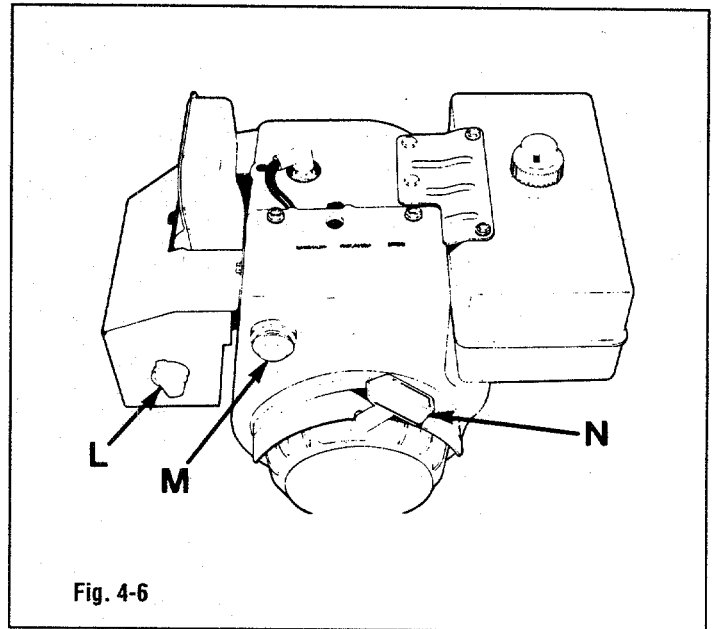

Fig. 4-6

Section 5

Operation

Pre-Start Checklist

1. Review "Safety" and "Controls".
2. Check unit for loose or missing hardware. Service as required.
3. Check engine oil level.
4. Check gas level in tank.
5. Check skid shoes and scraper blade for wear and proper adjustment.
7. Check discharge chute crank for freedom of movement. Adjust discharge chute and deflector cap to desired direction and angle of discharge.
8. Make sure chute guard is installed.
9. Check handlebar control levers for freedom of movement.
10. Inflate tires evenly (8 to 12 psi).

NOTE: To help prevent snow from sticking inside deflector, spray discharge chute and auger-impeller housing with silicone lubricant.

Filling Fuel Tank

1. Fill tank as follows:

DANGER

- EXPLOSION AND FIRE HAZARD.**
- Never fill gas tank when engine is running or hot. Allow engine and muffler to cool at least two minutes before refueling.
 - DO NOT allow flames, sparks, matches or smoking within 50 feet of unit.
 - Fill fuel tank outdoors in a well-ventilated area.
 - Wipe up all spills and move unit away from gasoline fumes before starting engine.
 - Store gasoline in an approved gasoline container out of reach of children.

DANGER

- EXPLOSION AND FIRE HAZARD.**
- Store gasoline only in a well-ventilated area.
 - DO NOT store gasoline where vapors may reach an open spark or flame.
 - Never refuel gas tank with optional electrical starter installed.

- A. Unscrew gas tank cap.
- B. Insert a clean funnel into gas tank or use a fuel container with a flexible pour spout to pour gas into tank.
- C. DO NOT fill gas tank completely. Leave approximately 1/2" (13 mm) of air space between fuel and tank neck.
- D. Reinstall gas tank cap and wipe up spilled gas.

Operation (continued)

Starting

1. Turn ignition key to RUN.
2. Move choke knob to FULL CHOKE (warm engines require little or no choking). Push pre-starting primer button two or three times. If engine is warm, push primer button once. If temperature is below 15° F., you may have to push button more than 2 or 3 times.
4. Move engine control lever to FAST.
5. Release auger and wheel drive levers.
6. **To start engine with recoil starter:**

A. Before using recoil starter, make sure there are no obstacles behind you. Place one hand on handlebar to stabilize unit when you pull starter rope.

B. Pull rope handle until you feel resistance. At point of resistance, pull rapidly and vigorously. Maintain control of rope so it slowly returns into starter mechanism. Repeat pulling actions until engine starts.

C. Gradually move choke knob to NO CHOKE as engine warms up.

For optional 110V electric starter:

WARNING

- **DO NOT use 110V electric starter during rainy weather.**
- **DO NOT stand in puddles or on damp surfaces when connecting cord.**
- **DO NOT run engine indoors or in poorly-ventilated areas.**

A. Plug electrical cord into switchbox on top of engine.

B. Plug other end of electrical cord into a properly grounded 110V outlet.

C. Push starter button on top of switchbox. As soon as engine starts, release button.

NOTE: Starter is thermally protected. When overheated from continuous use, starter will automatically stop functioning. Allow starter to cool for several minutes before making further attempts to start engine.

D. After engine starts, gradually move choke knob to NO CHOKE as engine warms up.

Testing Auger and Wheel Drive

WARNING

PERSONAL INJURY HAZARD.

- **DO NOT use snowthrower if auger spins before you squeeze auger drive lever.**
- **DO NOT use snowthrower if auger continues to spin after you release auger drive lever.**

1. To test auger drive, squeeze and release auger drive lever. Auger should begin spinning when lever is squeezed and stop spinning when lever is released.

2. To test wheel drive, shift into first gear.

WARNING

PERSONAL INJURY HAZARD.

- **DO NOT use snowthrower if wheels turn before you squeeze wheel drive lever.**
- **DO NOT use snowthrower if wheels continue to turn after you release wheel drive lever.**

3. Squeeze and release wheel drive lever. Wheels should begin turning when lever is squeezed and stop turning when lever is released.

4. Move gear shift lever to desired gear. Starting in first gear is not necessary.

4. If both handlebar levers operate properly, re-engage and begin operation.

NOTE: To move unit without throwing snow, engage wheel drive lever. Leave auger drive lever disengaged (released) while moving.

Stopping

To quickly stop snowthrower:

1. Release both handlebar levers.

2. Turn ignition key to OFF position.

To stop snowthrower (normal conditions):

1. Release both handlebar levers.
2. Move throttle lever to idle position. Allow engine to run at idle for several minutes to melt snow off engine.

To help avoid possible freezing of starter when snowthrower is not in use:

1. *For pull start engines:*

With engine OFF, pull recoil starter rope all the way out. Repeat 3 or 4 times.

For engines with 110V electric start kit installed:

A. Connect electrical cord to switchbox.

B. Connect other end of cord to 110V outlet.

C. With engine OFF, push starter button and spin starter for several seconds.

D. Disconnect electrical cord from outlet, then from switchbox.

2. Turn ignition key to OFF.

3. Disconnect spark plug wire and prevent it from touching spark plug.

To help avoid possible freezing of controls:

1. Wipe engine of all snow and moisture in, on, near and around throttle control lever linkage and choke knob. Spray linkage and levers with a non-silicone lubricant.

2. Move throttle control lever and choke knob back and forth several times.

3. Move choke to FULL CHOKE and leave in this position.

4. Move throttle to start position and leave it there.

5. Close fuel valve located beneath fuel tank.

Changing Gears

Begin operating in any gear, including reverse. Shifting from first gear through fifth is not necessary.

CAUTION

Unit must be completely stopped while shifting. Damage to transmission will result if this instruction is not followed.

- **DO NOT shift while in motion!**

DO NOT shift from one gear into any other with unit in motion. Damage to transmission may result. Allow unit to stop completely before shifting into any other gear, especially before shifting into reverse.

To shift into reverse:

1. Release both handlebar levers (auger drive wheel drive levers). Allow unit to come to a complete stop.
2. Move gear control lever into reverse.

CAUTION

Failure to follow this instruction could result in personal injury or property damage.

- **Before engaging wheel drive lever, look behind for and avoid obstacles.**

3. Slowly begin squeezing wheel drive lever and guide unit rearward.
4. Allow unit to stop completely before shifting into a forward gear.

Before shifting to another gear, release handlebar levers. Allow unit to stop completely. Then, move gear control lever re-engage wheel drive lever. Wheel drive lever may be engaged with gear control lever in any gear, including reverse.

Snowthrowing Tips

Run engine at full throttle when throwing snow. Use slower wheel speed (first or second gear) in heavy, wet snow.

Spray auger, inside auger housing, inside discharge chute and inside deflector chute with silicone spray to help prevent snow from sticking.

Inspect operating area before snowfall.

Remove all objects from surface such as rocks, mats, boards, wires, nails, etc.

For best results, remove snow as soon as possible after it falls.

Slightly overlap your previous path on each pass to help assure complete snow removal.

Throw snow downwind whenever possible, or snow may blow back.

When throwing snow from a smooth area, adjust skid shoes so scraper blade to ground clearance is approximately 1/8" (3 mm). When operating on gravel-covered or similar terrain, adjust skid shoes so scraper blade clears gravel.

WARNING

- **DO NOT use hands or feet to dislodge snow stuck in deflector chute or auger!**
- **Shut engine off, disconnect spark plug wire from spark plug and prevent wire from contacting plug.**
- **Use a stick at least three feet long to unclog snowthrower.**

DO NOT use hands or feet to dislodge snow stuck in deflector chute or auger. Shut engine off, disconnect spark plug wire and prevent it from touching spark plug. Use a long stick (at least three feet long) to unclog deflector chute or auger.

Operation (continued)

Snowthrowing Patterns

Use pattern in Fig. 5-1 when snow cannot be thrown to one side. Begin throwing snow closest to the side where it cannot be thrown, angling discharge chute to direct snow away from that side. When turning unit around after each pass, crank

discharge chute as you proceed so snow is thrown in proper direction.

Use pattern in Fig. 5-2 to throw snow on both right and left sides. When turning snowthrower, crank discharge chute as necessary to throw snow in proper direction.

As you turn, rotate the discharge chute so that snow is always thrown in this direction.



Snow is *not* thrown to this side.

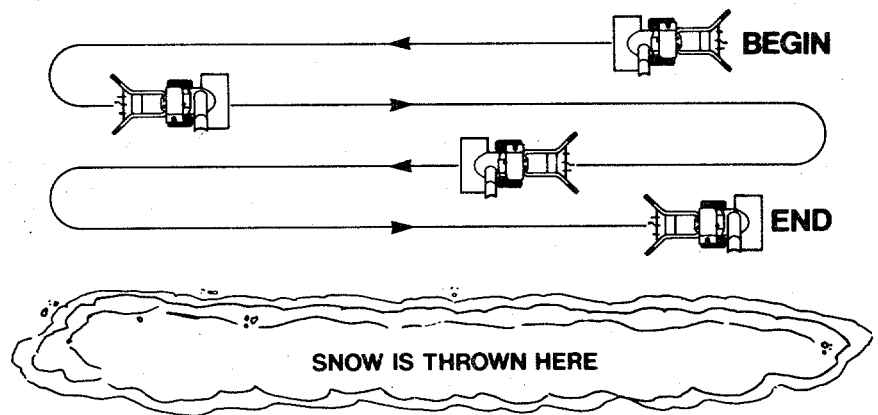

Fig. 5-1

Discharge chute direction stays the same except when turning.

Snow is thrown to each side.

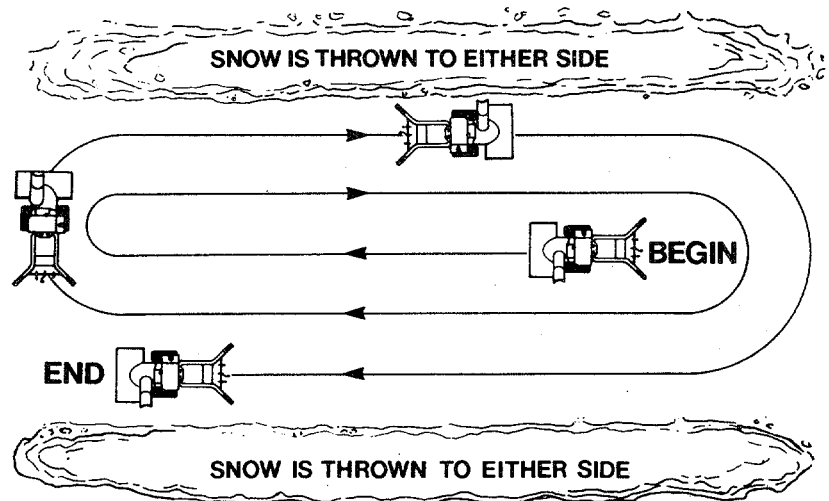

Fig. 5-2

Maintenance

Checking and adding oil

1. Shut engine off. Unscrew oil fill cap/dipstick (AM, Fig. 6-1) and wipe with clean, lint-free cloth.

2. Re-insert and firmly screw dipstick into oil fill tube (AL), then unscrew and check oil level. Level should be between FULL and ADD marks on dipstick. Add oil as necessary.

NOTE: DO NOT overfill. Damage to engine seals may result.

Changing oil

IMPORTANT: After the first two hours of use, change engine oil.

After initial change, change oil every 25 hours of operation or at end of each snowthrowing season.

1. To change engine oil, start and run engine to operating temperature.

2. SHUT ENGINE OFF.

3. Fold a piece of cardboard approximately 3" x 6" (7.5 x 15 cm) in size lengthwise into a shallow V-shape (see Fig. 6-2).

4. Loosen BUT DO NOT REMOVE engine oil drain plug cap (AK, Fig. 6-1). Place folded cardboard beneath drain as shown in Fig. 6-2.

5. Place a suitable container (minimum capacity: 1 quart) underneath end of cardboard to catch draining oil. Slowly, unscrew oil drain plug cap. Allow oil to run down cardboard and into container. After oil stops draining, reinstall oil drain plug cap.

6. Unscrew oil fill cap/dipstick and wipe with a clean, lint-free cloth. Insert a clean funnel into oil filler tube.

7. Add fresh, clean oil of correct type (see engine owner's manual) through funnel and into oil filler tube. Engine will hold approximately 26 ounces of oil. Check oil level.

NOTE: DO NOT overfill. Overfilling engine may damage engine seals.

8. Wipe up oil spills and drips immediately. Dispose of oil in accordance with local regulations.

Spark Plug

Yearly or after every 100 hours of operation, remove, clean and inspect spark plug.

Clean plug by scraping (don't wire brush or sandblast) deposits and residue away.

Replace spark plug with new one of same type (see engine owner's manual) if electrodes are pitted or burned or if porcelain is cracked.

If your unit came equipped with a resistor-type spark plug when new, always replace with a resistor-type spark plug. Refer to the engine owner's manual.

Before installing spark plug, set electrode gap to 0.030" (0.80mm). See Fig. 6-3.

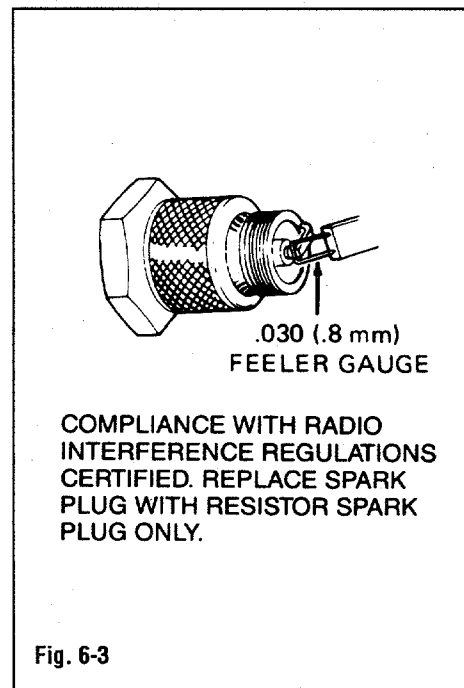
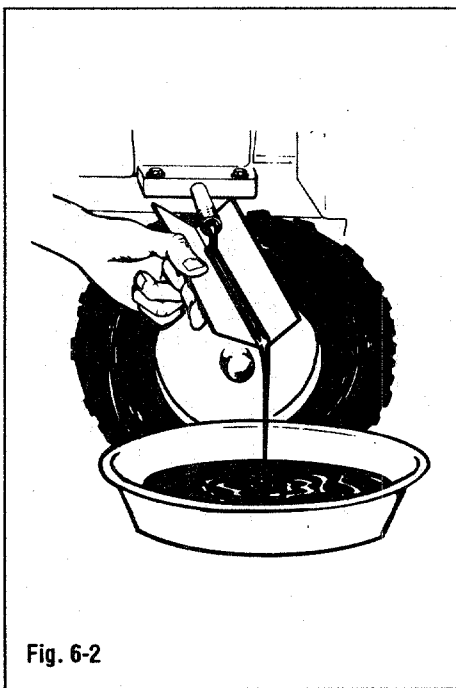
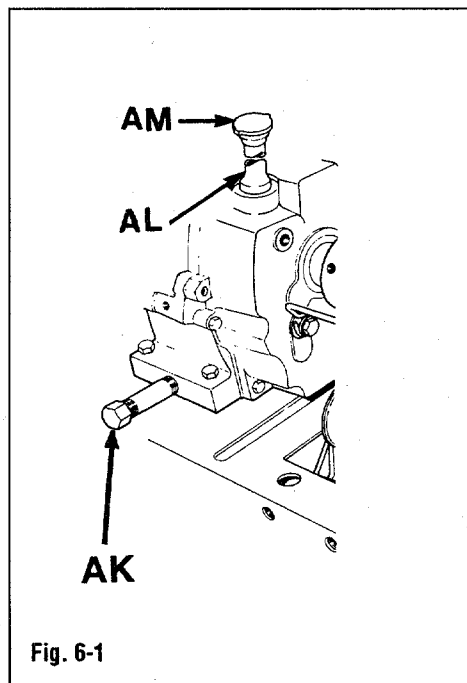

Maintenance (continued)

Lubrication

At the beginning and end of each season or after every 25 hours of operation, lubricate unit as recommended below.

1. Lightly oil both deflector chute cap pivot points (D, Fig. 6-4) located on each side of the deflector chute cap.
2. Apply oil to discharge chute control rod pivot points where crank enters:
 - A. Control panel rear lip (A, Fig. 6-5);
 - B. Support tab on front edge of control panel (B, Fig. 6-5);
 - C. Support on left rear end of snowthrower housing (S, Fig. 6-7).
3. Remove left-hand wheel (J, Fig. 6-4). Clean wheel shaft and apply fresh bearing grease to shaft. Reinstall left-hand wheel.
4. Apply oil to bearings on sides of auger shaft (P, Fig. 6-4). Wipe off excess oil.
5. Clean dirt and remove old grease from toothed portion on flange at bottom of discharge chute (B, Fig. 6-4). Apply fresh grease to worm gear, toothed portion of flange and flange. Adjust lock nut (R) and friction shims (S) to help prevent force of snow discharge from turning chute. Periodically check tightness of lock nut (R). Do not overtighten lock nut (R).
6. Lubricate handlebar levers at pivot points (C, Fig. 6-5) with engine oil or a non-silicone spray. DO NOT get oil or lubricating spray on levers.
7. Apply a few drops of clean engine oil to pivot points on throttle control lever and gear shift control lever (D, Fig. 6-5).
8. Remove shear bolts from auger shaft, then lubricate the four auger grease fittings (O, Fig. 6-6) using a grease gun dispensing multipurpose automotive lubricant. Carefully and slowly spin auger three or four times. Reinstall shear bolts.

NOTE: If replacing an auger shear bolt, order part number 1735625. Only use auger shear bolts supplied by Bolens. Other bolts may not shear properly and could cause damage to unit.

9. Check oil level in auger gear box:

A. Place snowthrower on smooth, level surface. Unscrew plug (R, Fig. 6-6) from front of gear box.

B. Inspect plug hole. Oil should just begin to seep out of hole. If oil does not appear, add SAE 90 gear oil until oil just begins to flow out of hole.

C. Reinstall plug. Wipe oil from gear box, snowthrower and work surface.

10. Remove bolts (V and W, Fig. 6-7) securing bottom cover to unit. Remove bottom cover. Apply a light coating of grease to shafts (A and B, Fig. 6-9). Prevent grease from contacting rubber drive wheel (C) or dripping onto drive disc (D). If grease should contact these parts, clean thoroughly to deter slippage and help assure trouble-free operation.

Wheel Drive Belt Adjustment

To check wheel drive belt tension:

1. Measure length of spring (T, Fig. 6-7) on lower end of wheel drive control rod (Z). Squeeze wheel drive control lever. Hold lever down and remeasure length of spring. Spring should now measure 11/16 in. +/- 1/16 in. (17 mm +/- 1.5 mm) longer than first measurement.

2. If difference between measurements is not 11/16 in., adjust belt tension:

A. Loosen jam nut (U, Fig. 6-7). Turn adjuster (X) up the control rod to increase or down to decrease distance measured in step 1 (each 1-1/4 turn of adjuster will equal 1/16 in. (1.5 mm) of spring extension).

B. Repeat step 1. If difference in measurements is not 11/16 in., repeat adjustment. When measurement difference is 11/16 in., tighten jam nut (U) against adjuster (X).

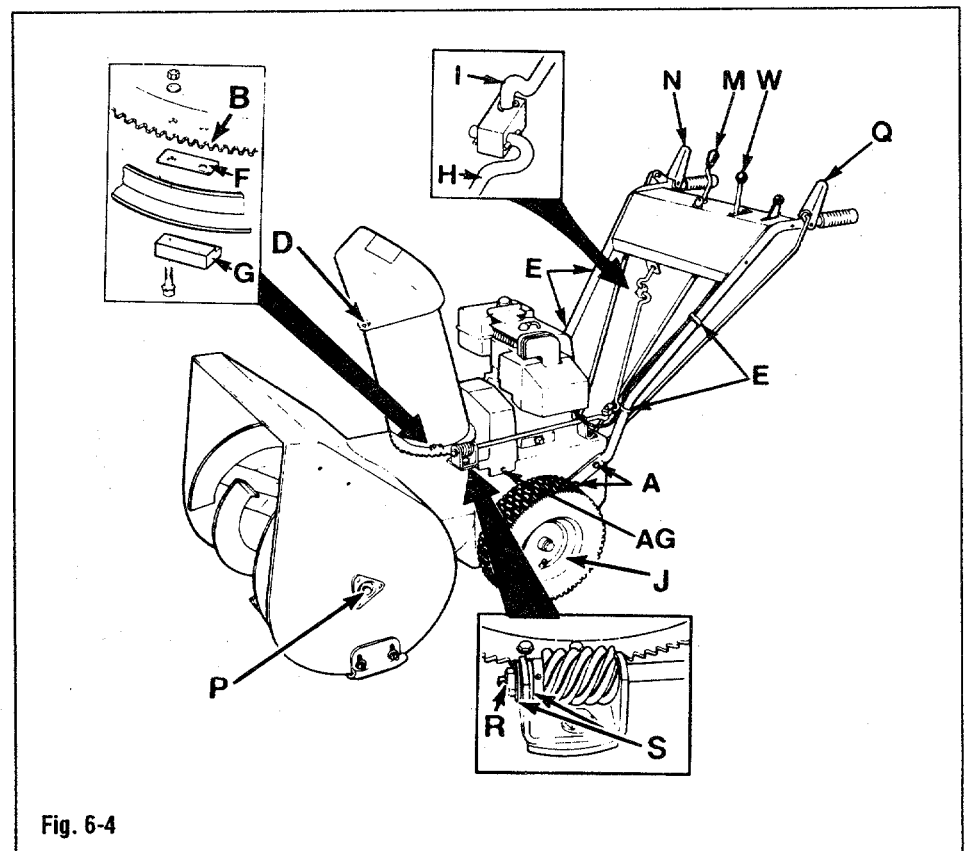

Fig. 6-4

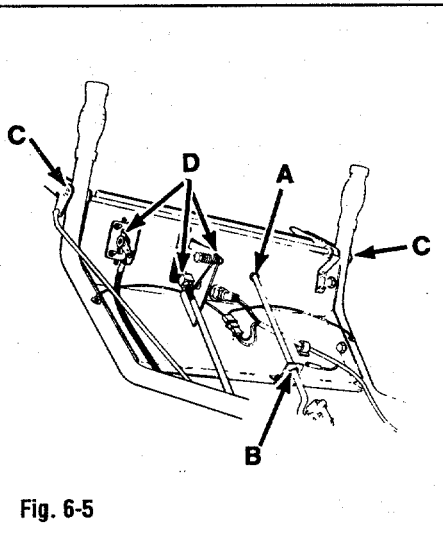

Fig. 6-5

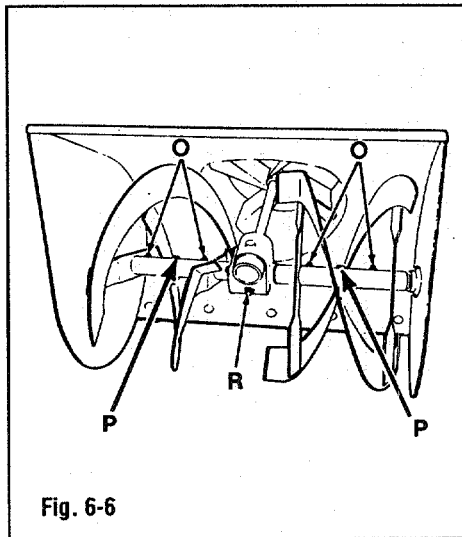

Fig. 6-6

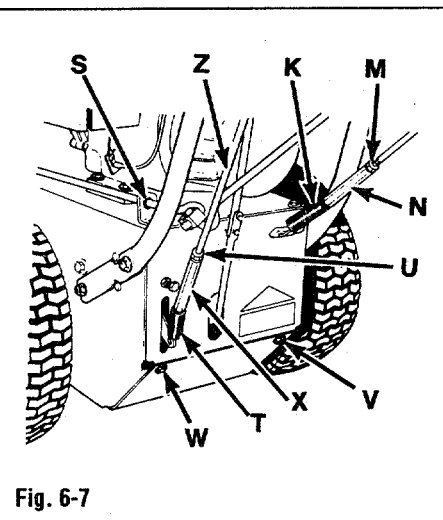

Fig. 6-7

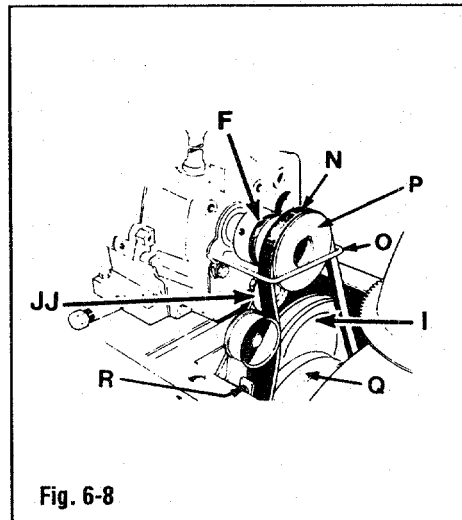

Fig. 6-8

Wheel Drive Belt Replacement

To replace wheel drive belt:

1. Remove two bolts (AG, Fig. 6-4) and belt cover from unit.
2. Remove two bolts securing belt guide (O, Fig. 6-8) to back of engine. Remove belt guide.
3. Move auger drive belt (N) out of groove in auger drive pulley (P). Release tension on idler (JJ).
4. Move wheel drive belt (F) off lower drive pulley (I). Depress wheel drive handle on left handlebar (Q, Fig. 6-4) to increase gap between lower pulleys as needed. Move lower part of wheel drive belt up through gap.
5. Move belt off upper drive pulley. Remove belt from unit.
6. Insert lower end of wheel drive belt down through gap between both lower drive pulleys. Place lower end of belt into lower drive pulley groove.
7. Pivot idler (JJ, Fig. 6-8) rearward. Place upper end of belt into groove closest to engine. Reinstall auger drive belt in its pulley groove.
8. Reinstall belt guide (O). Perform wheel drive belt adjustment.
9. Reinstall belt cover.

Auger Drive Belt Adjustment

Eventually, due to wear, auger drive belt may begin to slip when auger drive handle is engaged. To adjust auger drive belt:

1. Check spring (K, Fig. 6-7) tension as follows:
 - A. Measure spring length.
 - B. Engage auger drive control lever. Hold lever down and remeasure spring length. Difference should be 11/16 in. +/- 1/16 in. (17 mm +/- 1.5 mm).
2. If difference is not 11/16 in., adjust control rod as follows:

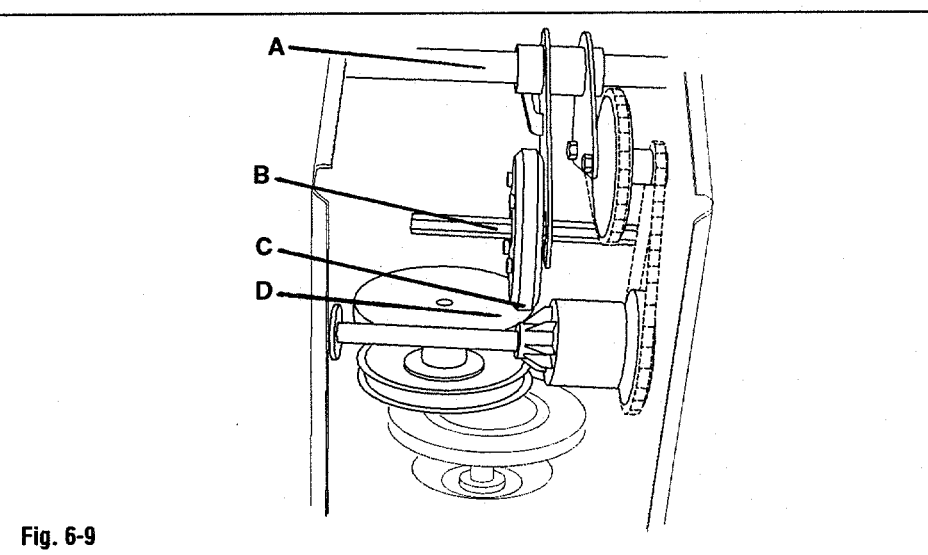

Fig. 6-9

Maintenance (continued)

A. Loosen jam nut (M) seated against adjuster (N) on lower end of control rod. Turn adjuster (N) up the rod to increase spring length or down to decrease length. Each 1-1/4 turn of adjuster (N) equals 1/16" (1.5 mm) of spring length.

B. Repeat as necessary until 11/16 in. +/- 1/16 in. (17 mm +/- 1.5 mm) difference between both spring measurements is obtained, then tighten jam nut (M) against adjuster (N).

3. Ensure that there is 1/16 - 1/8 in. (1.5-3 mm) of clearance between brake arm and auger drive belt. See "Brake Arm", page 7.

Auger Drive Belt Replacement

To remove auger drive belt:

1. Remove two bolts securing belt cover (AG, Fig. 6-4) to snowthrower. Remove belt cover.
2. Remove two bolts securing belt guide (O, Fig. 6-10) to back of engine. Remove belt guide.
3. Move auger drive belt (N) out of groove in auger drive pulley (P).
4. Move lower part of auger drive belt off lower drive pulley (Q). To allow more room for belt removal, pull brake arm (R) outward.

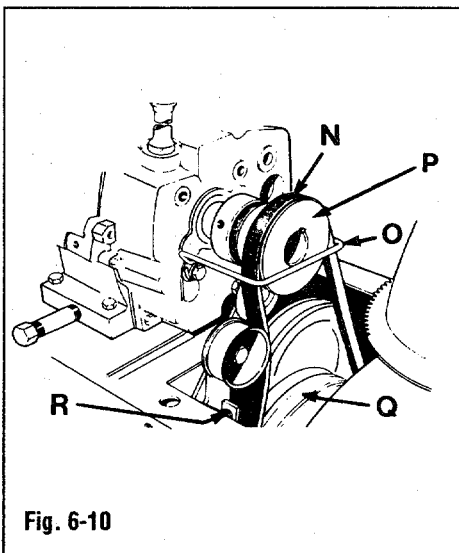

5. Move lower part of auger drive belt up through gap between lower pulleys.

To install auger drive belt:

1. Push lower end of auger drive belt (N) down through gap between both lower drive pulleys. Move belt forward and place in lower drive pulley (Q) groove. When placing lower end of auger drive belt on pulley, push outward on brake arm (R) for additional clearance.
2. Place upper end of auger drive belt (N) into groove in pulley (P). Reinstall belt guide (O).
3. Check auger drive belt and adjust as necessary. See "Auger Drive Belt Adjustment" on page 17.
4. Reinstall belt cover.

Slip Differential Adjustment

1. Remove black plastic cover (A, Fig. 6-11) at end of right-hand axle shaft. Remove outer jam nut (B). Remove inner jam nut (C) and both pairs (four single) of disc springs (D). Each pair consists of two curved washers aligned so the concave side of one washer faces the concave side of the other washer. Reinstall disc springs (D) and inner jam nut (C). Tighten jam nut (C) by hand until it contacts disc spring, then tighten 1 to 1-1/4 turns more. DO NOT force nut further than 1-1/4 turns or slip differential will not work properly.

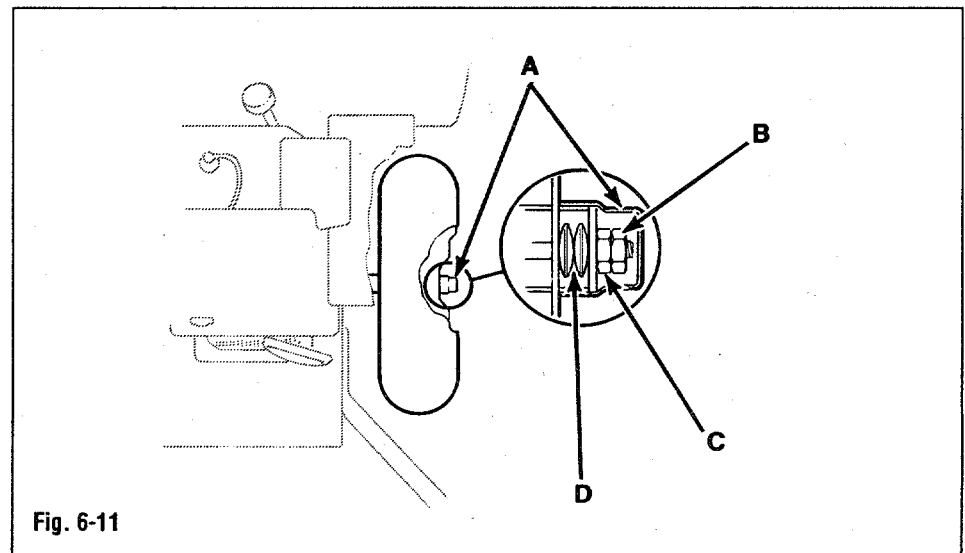

2. Reinstall outer jam nut (B). Hold inner nut (C) in place. Use wrench to tighten outer nut (B). Reinstall black plastic cover (A) at end of right-hand axle shaft.

Drive Disc Clearance Adjustment

If gear shift lever does not move freely through all positions in shift quadrant with wheel drive lever disengaged, adjustment may be required.

1. Remove bolts attaching bottom plate to rear of chassis. Remove plate.
2. Check clearance (A, Fig. 6-12) between disc and rubber drive wheel. Clearance should measure between 0.060" and 0.125" (3-15 mm) when wheel drive lever is disengaged (released). If clearance is correct, drive disc clearance adjustment is correct.

To adjust:

- A. Loosen jam nut (C, Fig. 6-13). Turn adjusting screw (D) until clearance is correct.
- B. Tighten jam nut and re-check clearance. Ensure that gear shift lever moves without hindrance through all positions in shift quadrant.
3. Slide bottom plate back into place. Secure with bolts previously removed.
4. Perform auger drive belt adjustment.

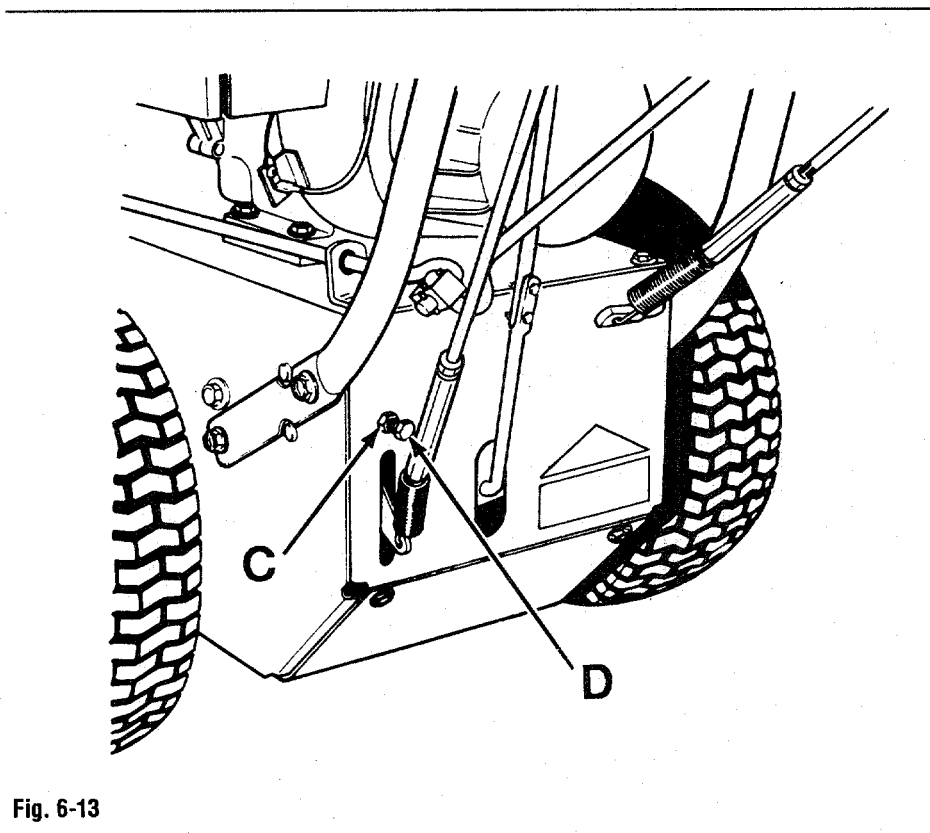
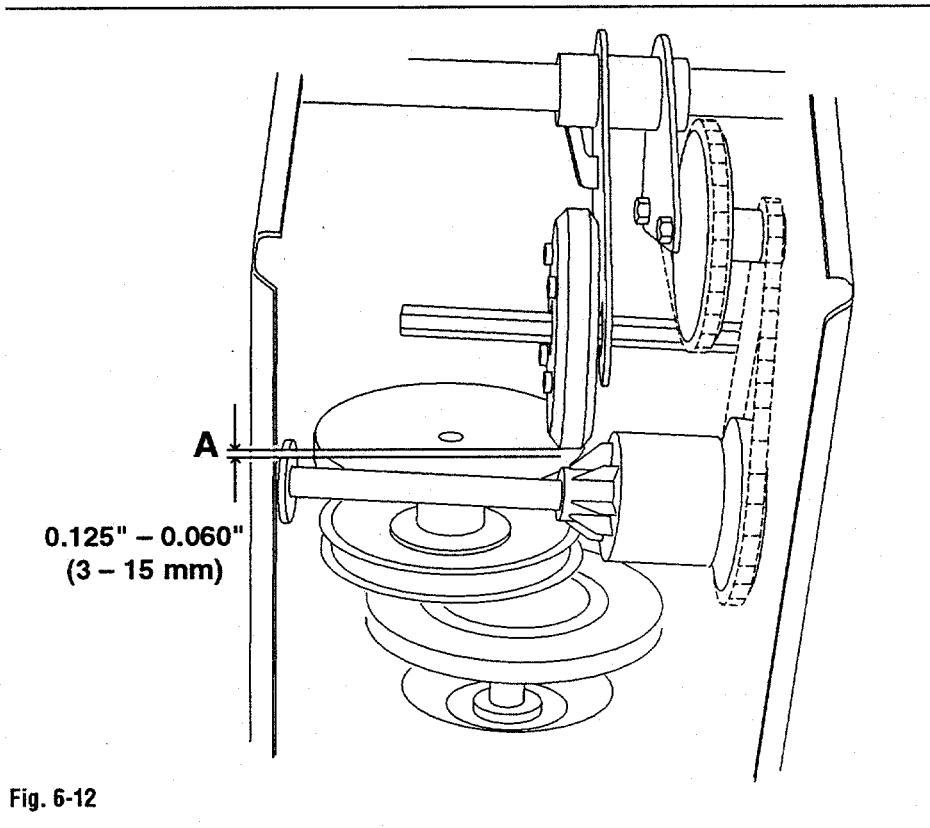

Maintenance (continued)

Maintenance Chart

Interval	Item	Service
Before each use	Engine oil All fasteners Auger drive lever Wheel drive lever	Check level and condition Check for tightness Check operation Check operation
After each use	Handlebar control levers and linkages Snowthrower	Lubricate Remove all snow, slush and ice
Every 25 hours of operation or once a year	Engine oil Tires Auger gear box Belts Cooling air screen Spark plug	Change Check pressure and condition Check oil level Check for wear Check condition and clean Check, clean, regap or replace
Every 50 hours of operation or once a year	Drive system shafts Drive chains	Remove bottom panel of snowthrower and lubricate drive system shafts with multipurpose grease (page 10) Apply oil to drive chains
At end of snowthrowing season	Belts Brake Auger Rusted areas Snowthrower	Check for wear, damage and adjustment Adjust Grease (through grease fittings) Sand, repaint Lubricate

This table describes service guidelines only and does not provide complete service information. For complete service information, contact your local authorized Bolens dealer. A more detailed repair manual for this snowthrower is available from your dealer.

Storage

- Clean snowthrower and engine.
- Perform routine lubrication.
- Drain gasoline from fuel tank (see engine owner's manual) to help prevent build up of gum deposits and help reduce possibility of fire or explosion.
- Change engine oil.
- Remove spark plug. Pour one ounce of clean engine oil into spark plug hole. Pull recoil rope slowly two or three times.
- DO NOT store snowthrower in building or enclosure where fumes may reach an open flame or spark or where an ignition source is present (hot water and other heaters, furnaces, clothes dryer, etc.). Follow all safety instructions (pages 4-5).
- Repair scratches and rust, especially to inner portion of discharge chute.
- Inspect snowthrower thoroughly and order any needed replacement parts from your nearest factory-authorized Bolens dealer.

Troubleshooting

TROUBLE	POSSIBLE PROBLEM	SOLUTION
Engine won't start	Ignition key in OFF position	Turn key to ON position
	Choke knob not set to FULL CHOKE position (cold engine)	Move choke knob to FULL CHOKE position
	Engine control lever in incorrect starting position	Move engine control lever to correct starting position
	Engine not primed enough (when cold)	Push primer button several more times
	Engine primed too much (when cold)	Move choke knob to OFF position, move engine control lever to idle position, attempt to start engine, then proceed with normal starting procedure
	Spark plug wire disconnected	Connect spark plug wire to spark plug
	Fouled spark plug	Remove, clean, inspect, re-gap or replace spark plug
	Gas tank empty	Fill gas tank
Engine difficult to start	Fuel shutoff valve is closed	Open fuel shutoff valve
	Incorrect choke knob setting	Move choke knob to correct setting
	Engine control lever in incorrect position	Move engine control lever to correct starting position
	Fuel shutoff valve closed	Open fuel shutoff valve
	Engine not primed enough	Push primer button several more times
	Stale gas in tank	Drain gas from tank, refill tank with fresh gas
Engine idles rough	Faulty spark plug	Remove, clean, inspect, re-gap or replace spark plug
	Incorrect choke setting	After engine starts, gradually move choke knob to NO CHOKE position
Engine overheats	Dirty air screen	Remove all debris from screen
	Low engine oil level	Check oil, add as necessary
	Dirty cooling fins	Clean cooling fins
	Loose spark plug	Disconnect spark plug wire, re-tighten plug
Auger drive lever does not actuate auger	Inadequate tension on spring at lower end of auger drive control rod	Increase tension on spring
	Broken auger shear bolts	Replace auger shear bolts
	Loose or broken spring	Replace spring

Maintenance (continued)

TROUBLE	POSSIBLE PROBLEM	SOLUTION
Auger drive lever does not actuate auger	Broken square key on engine drive pulley	Replace key
	Broken woodruff key on input shaft	Replace key
Auger spins with drive lever disengaged	Excessive tension on spring at lower end of auger drive control rod	Decrease spring tension
Wheel drive lever does not turn wheels	Inadequate tension on spring at lower end of wheel drive control rod	Increase spring tension
	Broken wheel drive chain(s)	Replace chain(s)
	Drive disc out of adjustment	Readjust drive disc
	Broken or excessively worn wheel drive belt	Replace wheel drive belt
Wheels turn with drive lever disengaged	Broken square key on engine pulley	Replace key
	Excessive tension on spring at lower end of wheel drive control rod	Adjust spring tension
Snowthrower does not throw snow well	Drive disc out of adjustment	Adjust drive disc
	Discharge chute, impeller or auger clogged with snow, slush or ice	Stop engine, disconnect spark plug wire, use a long stick to unclog chute, auger and/or impeller
	Snow sticks to auger or chute	Spray auger and chute with silicone lubricant
	Incorrect wheel speed setting	When snowthrowing, generally use faster speeds – use slower speeds with heavier snow
	Loose auger drive belt	Adjust auger drive belt
Snowthrower does not clear snow	Skid shoes set too high	Adjust skid shoes equally until scraper blade is 1/8" (3 mm) above surface
	Scraper blade adjusted incorrectly	Adjust scraper blade until blade is 1/8" (3 mm) above surface being cleared
Snowthrower makes sloping cut in snow	Skid shoes not set at equal height	Adjust skid shoes to equal height
	Scraper blade adjusted incorrectly	Adjust scraper blade ends equally
Electric start motor won't crank engine	Electrical cord unplugged from outlet	Plug electrical cord into outlet
	Blown fuse or thrown circuit breaker	Replace fuse or re-set circuit breaker
	Faulty electrical cord or plug	Replace electrical cord
	Overheated starter	Allow starter motor to cool before trying to start engine again

Specifications

Below is a list of specifications for your snowthrower. The information is the most current at the time this manual was printed.

Snowthrower Models 824A & 1026	
Snowthrower	
Height	To top of handlebar levers: 41.5" (105.3 cm)
w/o handlebars, deflector cap down: 33" (83.75 cm)
Length	With handlebars: 70" (177.6 cm)
	Without handlebars: 41.0" (104 cm)
Weight	
824A	295 lbs. (134 Kg)
1026	315 lbs. (143 Kg)
Tires	
Type	2-ply
Size	4.80/4.00 x 8
Air Pressure	8 to 12 psi (55-82 kPa)
Clearing Width	24" (61 cm) / 26" (65.6 cm)
Engine	
824A	8 HP (5.97 kW) Tecumseh
	"Snow King" winterized Model HMSK80
1026	10 HP (7.46 kW) Tecumseh
	"Snow King" winterized Model HMSK100
Type	Winterized, 4-cycle, air-cooled, 1-cylinder, aluminum alloy "L"-shaped cylinder head, aluminum alloy block with cast-iron sleeve, cast-iron horizontal crankshaft, counter-clockwise rotation (as viewed from PTO end)
Displacement	
824A	42.18 cid (0.691 L)
1026	49.98 cid (0.769 L)
Bore x Stroke	
824A	3.125 x 2.5312 in. (79.9 x 64.31 mm)
1026	3.3125 x 2.5312 in. (84.14 x 64.31 mm)
Carburetor	Float type, primer and bowl drain, separate high speed and idle mixture adjustments with choke-winterized within heater box
Governor	Mechanical
High Speed	3450 RPM
Idle Speed	1700 RPM
Speed Setting	3450 RPM
Muffler	Aluminized, unpainted, with carburetor-side discharge
Lubrication	Splash system
Oil Fill	Extended oil fill and dipstick on top of cylinder
Oil Drain	Two sides
Engine Oil	
Type	Refer to engine owner's manual for manufacturer's recommendations
Capacity	26 U.S. ozs. (0.77 L)
Ignition	
Electronic	
Spark Plug	
Type	Champion J-8C, Autolite 356 or equivalent
Gap	0.030" (0.80 mm)
Size	14 mm
Starter	
Improved-type recoil (electric, optional)	
Fuel	
Type	Unleaded Regular
Tank	1 U.S. gallon (3.79 L), rustproof poly, center fill, fuel spill deflector, fuel shut-off valve
Filter	Fine mesh, molded into tank
Gear Case	
Type	Impeller shaft with worm gear
Gear Oil	SAE 90-weight gear oil
Wheel Drive	
7 speeds (5 Forward, 2 Reverse)	

Wiring Diagram

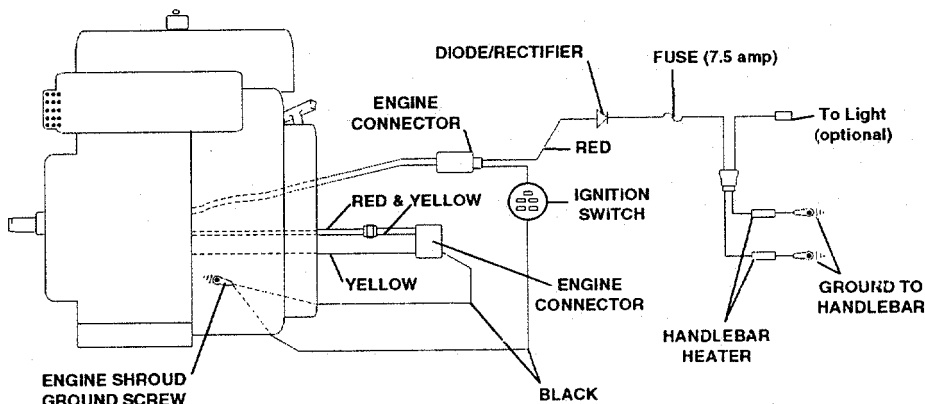

LIMITED WARRANTY

I. PRODUCTS COVERED

This warranty applies to all Bolens® branded equipment. Troy-Bilt® branded tractors, mulching mowers, snow casters, gas and electric sprayers, and all W-W Grinder® branded equipment to include their attachments and/or accessories and all Troy-Bilt® branded equipment sold as a commercial - institutional - industrial - rental or demonstrator application..

II. PRODUCT WARRANTY: NON COMMERCIAL RESIDENTIAL: THREE YEAR LIMITED WARRANTY

All new Bolens®, Troy-Bilt®, and W-W Grinder® equipment specified above is warranted by Garden Way, Inc. to the original retail purchaser only, to be free from defects in material and workmanship, under normal use and service for a period of three (3) years from date of purchase.

Engines manufactured by Briggs & Stratton, Kohler and Tecumseh or transmissions manufactured by Peerless will also be warranted for this three year warranty period through the authorized repair stations of their respective manufacturers.

EXCLUSIONS — The following items are not covered under the second and third year of this extended home use limited warranty: Belts, Hoses, Seats, Batteries, Blades, Knives, Tines, Filters, Tires, Wheels, Paint and Appearance Items, Light Bulbs, and similar items which are normally replaced through periodic maintenance.

III. PRODUCT WARRANTY: COMMERCIAL — INSTITUTIONAL — INDUSTRIAL — RENTAL — DEMONSTRATOR: ONE YEAR LIMITED WARRANTY

The Commercial, Institutional, Industrial, Rental and Demonstrator Limited Warranty covering defects on material and workmanship will be for a period of one (1) year, from date of purchase on all Bolens®, Troy-Bilt® and W-W Grinder® units and their manufactured attachments. This warranty applies to the original purchaser only.

Engines manufactured by Briggs & Stratton, Kohler and Tecumseh, and transmissions manufactured by Peerless will also be warranted for this one (1) year warranty period through the authorized repair stations of their respective manufacturers.

IV. GENERAL INFORMATION

Garden Way, Inc.'s obligation under this warranty is limited to the repair or replacement, at its option, by an authorized Garden Way equipment dealer, of any part found to be defective in material or workmanship, without charge for parts and labor.

In order to obtain warranty service, the owner is responsible for:

- 1) Providing proof of purchase documentation, ownership registration or copy of bill of sale.
- 2) Informing any authorized Garden Way equipment dealer of the defect and making the product available for repair.
(Charges for pick-up, delivery and service calls are not covered by this warranty.)

This warranty does not cover defects, malfunctions or failures caused by:

- 1) Use of unauthorized accessories or attachments.
- 2) Lack of reasonable and necessary maintenance as specified in the "Operation and Safety Instructions".
- 3) Misuse, accidents or normal wear.

DISCLAIMER OF CONSEQUENTIAL DAMAGES: GARDEN WAY, INC. SHALL NOT BE LIABLE UNDER ANY CIRCUMSTANCES FOR ANY INCIDENTAL OR CONSEQUENTIAL DAMAGES OR EXPENSE OF ANY KIND, INCLUDING BUT NOT LIMITED TO COST OF EQUIPMENT RENTAL, LOSS OF PROFITS OR COST OF HIRING SERVICES TO PERFORM TASKS NORMALLY PERFORMED BY THE EQUIPMENT.

LIMITATION OF IMPLIED WARRANTIES: ANY IMPLIED WARRANTIES, INCLUDING WITHOUT LIMITATION ANY IMPLIED WARRANTY OF MERCHANTABILITY OR FITNESS FOR A PARTICULAR PURPOSE, SHALL BE LIMITED IN DURATION TO A PERIOD OF THREE YEARS (1 YEAR IF PRODUCT IS PURCHASED FOR COMMERCIAL, INSTITUTIONAL, INDUSTRIAL, RENTAL OR DEMONSTRATOR USE) FROM THE DATE OF SALE.

SOME STATES DO NOT ALLOW THE EXCLUSION OR LIMITATION OF INCIDENTAL OR CONSEQUENTIAL DAMAGES, OR LIMITATIONS ON HOW LONG IMPLIED WARRANTY LASTS. THEREFORE, THE ABOVE LIMITATION OR EXCLUSION MAY NOT APPLY TO YOU.

This warranty gives you specific legal rights, and you may also have other rights which vary from state to state.

Free Manuals Download Website

<http://myh66.com>

<http://usermanuals.us>

<http://www.somanuals.com>

<http://www.4manuals.cc>

<http://www.manual-lib.com>

<http://www.404manual.com>

<http://www.luxmanual.com>

<http://aubethermostatmanual.com>

Golf course search by state

<http://golfingnear.com>

Email search by domain

<http://emailbydomain.com>

Auto manuals search

<http://auto.somanuals.com>

TV manuals search

<http://tv.somanuals.com>