

# TC9346A Series

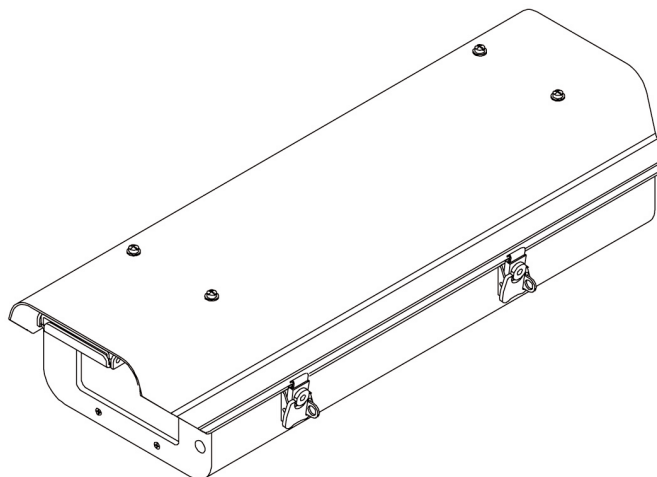

Security Systems

EN

Instruction Manual  
Environmental  
Enclosure

# BOSCH

---

---

# CONTENTS

---

---

<u>Section</u>	<u>Page</u>
1.0 GENERAL .....	3
1.1 IMPORTANT SAFEGUARDS AND WARNINGS .....	3
2.0 DESCRIPTION .....	4
2.1 MODELS .....	4
2.2 OPTIONAL ACCESSORIES .....	4
3.0 INSTALLATION .....	5
4.0 OPERATION .....	11
5.0 MAINTENANCE AND TROUBLESHOOTING .....	12
5.1 MAINTENANCE .....	12
5.2 TROUBLESHOOTING .....	12
6.0 SPECIFICATIONS .....	14

## LIST OF ILLUSTRATIONS

<u>Figure</u>	<u>Page</u>
1 Exploded Assembly Diagram for Blower and Circuit Board .....	5
2 TC9346A Series Input Wiring Diagram .....	9
3 Component Locations for Optional Circuit Board .....	12
4 Layout of Traces on Optional Circuit Board .....	12
5 Wiring Diagram for Optional Circuit Board (O/I-PCB) .....	13
6 TC9346A Dimension Drawing .....	15

## LIST OF TABLES

<u>Table</u>	<u>Page</u>
A 24 VAC Wiring Distances .....	10

### 1.1 IMPORTANT SAFEGUARDS AND WARNINGS

Prior to installation and use of this product, the following WARNINGS should be observed.

1. Installation and servicing should only be done by qualified service personnel and conform to all local codes.
2. Unless the unit is specifically marked as a NEMA Type 3, 3R, 3S, 4, 4X, 6, or 6P enclosure, it is designed for indoor use only and it must not be installed where exposed to rain and moisture.
3. Only use replacement parts recommended by manufacturer.
4. After replacement/repair of this unit's electrical components, conduct a resistance measurement between line and exposed parts to verify the exposed parts have not been connected to line circuitry.
5. The installation method and materials should be capable of supporting four times the weight of the enclosure, pan/tilt, camera and lens combination.

The product and/or manual may bear the following marks:



This symbol indicates that dangerous voltage constituting a risk of electric shock is present within this unit.



This symbol indicates that there are important operating and maintenance instructions in the literature accompanying this unit.

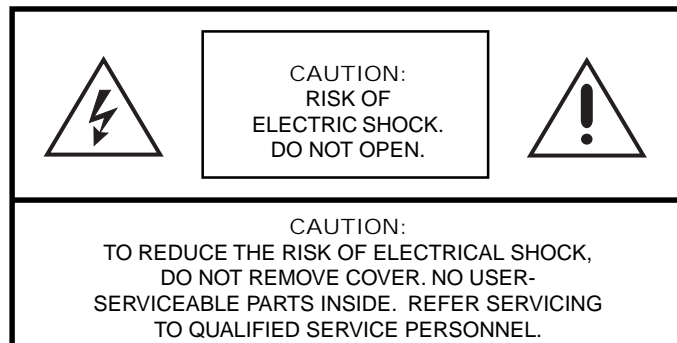

Please thoroughly familiarize yourself with the information in this manual prior to installation and operation.

---

---

## 2.0 DESCRIPTION

---

---

Environmental enclosures in the TC9346A Series are used with pan/tilt units or fixed mounts.

The enclosures are constructed of aluminum.

You can install cameras with either fixed focal length lenses or motorized zoom lenses. All models have an adjustable camera sled to accommodate different sizes of cameras and lenses.

### 2.1 MODELS

TC9346A	Environmental enclosure with rear-opening lid. Lid has gas spring to hold it open. 29-inch (73.66 cm) length.
TC9346A-1	TC9346A with 120 VAC thermostatically controlled heater and blower.
TC9346A-2	TC9346A with 24 VAC thermostatically controlled heater and blower.
TC9346A-3	TC9346A with 230 VAC thermostatically controlled heater and blower.

### 2.2 OPTIONAL ACCESSORIES

You can order the following optional accessories for the TC9346A Series enclosures:

BK57-1*	Blower kit, 120 VAC, 15 watts
BK57-2*	Blower kit, 24 VAC, 10 watts
BK57-3*	Blower kit, 230 VAC, 15 watts
HK57-1*	Heater kit, 120 VAC, 90 watts
HK57-2*	Heater kit, 24 VAC, 50 watts
HK57-3*	Heater kit, 230 VAC, 70 watts
O/I-PCB	Circuit board with thermostats
O/I-LPP*	Preset position lens wire harness (must be used with O/I-PCB)
O/I OUTLET*	120 VAC electrical outlet (must be used with O/I-PCB)
SS5729	Sun shroud
TI57	Thermal insulation kit
WD57-1*	Window defroster and defogger kit, 120 VAC, 30 watts
WD57-3*	Window defroster and defogger kit, 230 VAC, 30 watts
WD57-2*	Window defroster and defogger kit, 24 VAC, 30 watts
WW5729-1**	Window wiper kit, 120 VAC, 15 watts
WW5729-2**	Window wiper kit, 24 VAC, 15 watts
WW5729-3**	Window wiper kit, 230 VAC, 15 watts

\* These accessories are factory wired with a plug-in connector for use with the O/I-PCB. The O/I-PCB is included with all -1/-2/-3 models. You must order one O/I-PCB if you are using a basic enclosure (TC9346A) with these optional accessories.

\*\* Factory installed option only; consult factory for availability.

## 3.0 INSTALLATION

1. Unlatch and raise the enclosure lid. The gas spring will hold the lid in place when it is fully opened.
2. Remove the camera sled from the rail:
  - a. Loosen the screws.
  - b. Slide the sled so that the screws are in the large part of the mounting slots.
  - c. Remove the sled.
  - d. Remove the parts tied to the sled.
3. TC9346A-1, -2, -3 Models Only  
If you are installing the enclosure in a marine or high-moisture environment, make the following modifications to your enclosure:

Refer to Figure 1 for an exploded assembly diagram of the blower assembly.

- a. Disconnect the electrical plug (3) from the fan (4).
- b. Remove the three sets of screws and washers (A, B, and C) that secure the fan plate (5) and fan (4) to the enclosure.

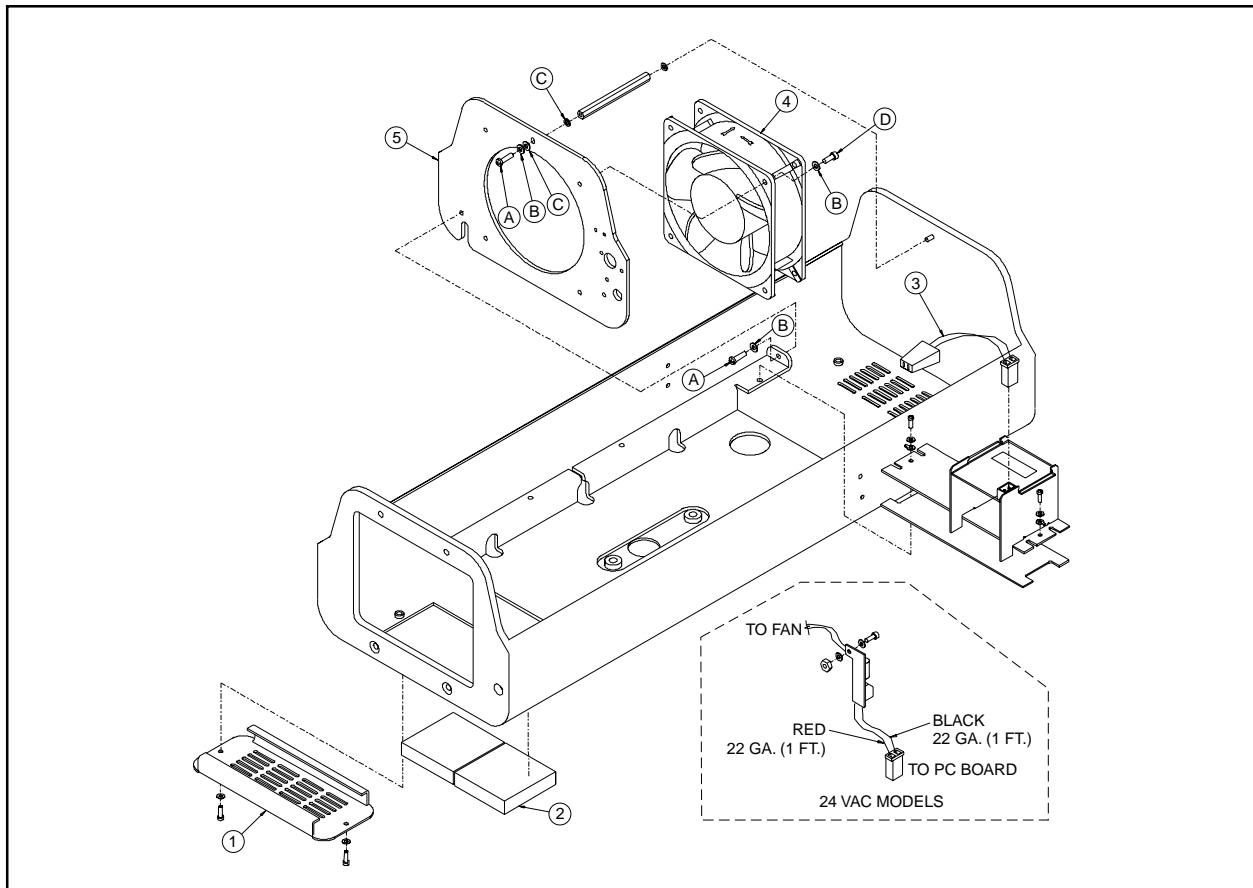

**Figure 1.** Exploded Assembly Diagram for Blower and Circuit Board

- c. Remove the four screws and washers (B and D) that secure the fan to the fan plate.
  - d. Turn the fan around so that it blows toward the viewing window (refer to the arrows on the fan).
  - e. Reinstall the fan on the fan plate.
  - f. Reinstall the fan plate and fan in the enclosure.
  - g. Reconnect the electrical plug on the fan.
  - h. Close the enclosure lid.
  - i. On the bottom of the enclosure, remove the vent grill (1) and filters (2) at the front of the unit. Replace the grill with one of the vent covers that was attached to the camera sled as loose equipment.
  - j. On the bottom of the enclosure, attach the other vent plate over the grill at the rear of the unit.
  - k. Open the enclosure lid.
4. If you are going to wire the enclosure with cable, remove the wiring glands and nuts from the parts bag and install them in the bottom of the enclosure. If you are going to wire the enclosure with conduit, do not install the glands.
  5. Mount the camera/lens to the sled with the 1/4-20 Phillips-head screws that are provided in the parts bag. You can mount the camera to either side of the U-shaped sled, depending on the camera height required.
  6. There are two threaded mounting holes on the bottom of the enclosure. Mount the enclosure to a pan/tilt assembly or fixed mount with 1/4-20 screws with threads that do not exceed 5/8 of an inch (1.59 cm) in length (not supplied with the enclosure).
  7. Install the sled and camera/lens in the enclosure:
    - a. If the camera's lens is adjustable, extend the lens to its maximum length.
    - b. Place the sled over the mounting screws in the enclosure.
    - c. Slide the sled forward until the camera's lens almost touches the window.
    - d. Tighten the screws to secure the camera sled to the enclosure.
  8. Wire the video output from the camera.
  9. If you are going to synchronize cameras, wire the camera's synchronization connection.
  10. If your camera has a motorized zoom lens control, wire it.

TC9346A Model Only – Wire the camera's lens control directly to the lens controller.

TC9346A-1, -2, -3 Models Only

Refer to Figure 2 and wire the motorized zoom lens control as follows:

- a. Connect or wire the lens control from the camera to the LENS or LENS CONTROL connector on the circuit board.



**WARNING:** *Camera damage possible. You can damage your camera if you connect it to the wrong connector.*

*If your camera will use the same power as the enclosure, plug the camera into the CAM 1 socket on the circuit board.*

*If your camera's voltage will be different from the enclosure's voltage, plug the camera into the CAM 2 socket. DO NOT plug the camera into the CAM 1 socket or you can damage your camera. CAM 1 has enclosure voltage on it.*

**BE CAREFUL - REMEMBER  
CAM 1 IS ENCLOSURE  
POWER**

**NEVER PLUG YOUR CAM-  
ERA INTO CAM 1 IF THE  
CAMERA'S VOLTAGE IS  
DIFFERENT FROM THE  
ENCLOSURE'S VOLTAGE.**

b. Wire the 10-connector INPUTS terminal on the circuit board to the lens controller as follows:

- **Lens Common** - Connector 1
- **Focus** - Connector 2
- **Zoom** - Connector 3
- **Iris** - Connector 4
- **Preset Common** - Connector 5
- **Preset Focus** - Connector 6
- **Preset Zoom** - Connector 7
- **Preset High** - Connector 8

11. TC9346A-1, -2, -3 Models Only

Refer to Figure 2 and connect the camera's power input to the circuit board.

There are two ways to supply power to the camera - when the power requirements for the camera and enclosure's accessories are the same (for example, if the camera and accessories use 24 VAC), and when the power requirements for the camera and the enclosure's accessories are different (for example, if the camera uses 24 VAC and the accessories use 120 VAC).

When the power requirements are the same, there are two ways to connect power:

(1) A three-pin plug is supplied as loose equipment. Connect the wires from the plug to the camera as follows:

- Brown - AC HI
- Blue - AC NT
- Green - Ground

Connect the plug to the CAM 1 socket on the circuit board (remove the plastic cover over the power supply section of the circuit board).

or

(2) If both the camera and enclosure use 120 VAC and you ordered the optional 120 VAC electrical outlet accessory (O/I-OUTLET), connect the 120 VAC plug to the camera and the three-pin plug to CAM 1 (remove the plastic cover over the power supply section of the circuit board).

When the power requirements are different, connect the wires from the two-pin plug, which is supplied as loose equipment, to the camera as follows:

- Brown - AC HI
- Blue - AC NT

Connect the plug to the CAM 2 socket on the circuit board.

12. Wire power to the enclosure to operate the camera.

TC9346A Model Only - Wire power directly to the camera. If you are using 24 VAC, refer to Table A to determine the size of wire to use.

TC9346A-1, -2, -3 Models Only

- CAM 1 - If the camera's power input is connected to CAM 1 on the circuit board, go to step 13.
- CAM 2 - If the camera's power input is connected to CAM 2 on the circuit board, wire power for the camera as follows:
  - a. Connect AC high to connector 9 of the 10-connector INPUTS terminal block (goes to the brown wire in the CAM 2 connector).
  - b. Connect AC neutral to connector 10 of the 10-connector INPUTS terminal block (goes to the blue wire in the CAM 2 connector).

13. TC9346A-1, -2, -3 Models Only

Wire power to the enclosure to operate accessories (and the camera if its power is connected to CAM 1 on the circuit board) as follows:

- a. Remove the plastic cover over the power supply section of the circuit board.
- b. Connect AC high to AC HI of the 3-connector terminal block.
- c. Connect AC neutral to AC NT of the 3-connector terminal block.
- d. Connect ground to GND of the 3-connector terminal block.
- e. Reinstall the plastic cover over the power supply section of the circuit board.

If the camera's power is connected to CAM 1 on the circuit board, add the camera's wattage to the power consumption of the accessories to determine the size of wire to use. If you are using 24 VAC, refer to Table A to determine the size of wire to use. Here are the wattages for the accessories:

Defrosters for all enclosures - 30 watts  
Wipers for all enclosures - 15 watts  
Blowers for 120 VAC enclosures - 15 watts  
Blowers for 24 VAC enclosures - 10 watts  
Blowers for 230 VAC enclosures - 15 watts  
Heaters for 120 VAC enclosures - 90 watts  
Heaters for 24 VAC enclosures - 50 watts  
Heaters for 230 VAC enclosures - 70 watts

14. Adjust the camera focus and iris, if necessary.
15. Close the enclosure lid.



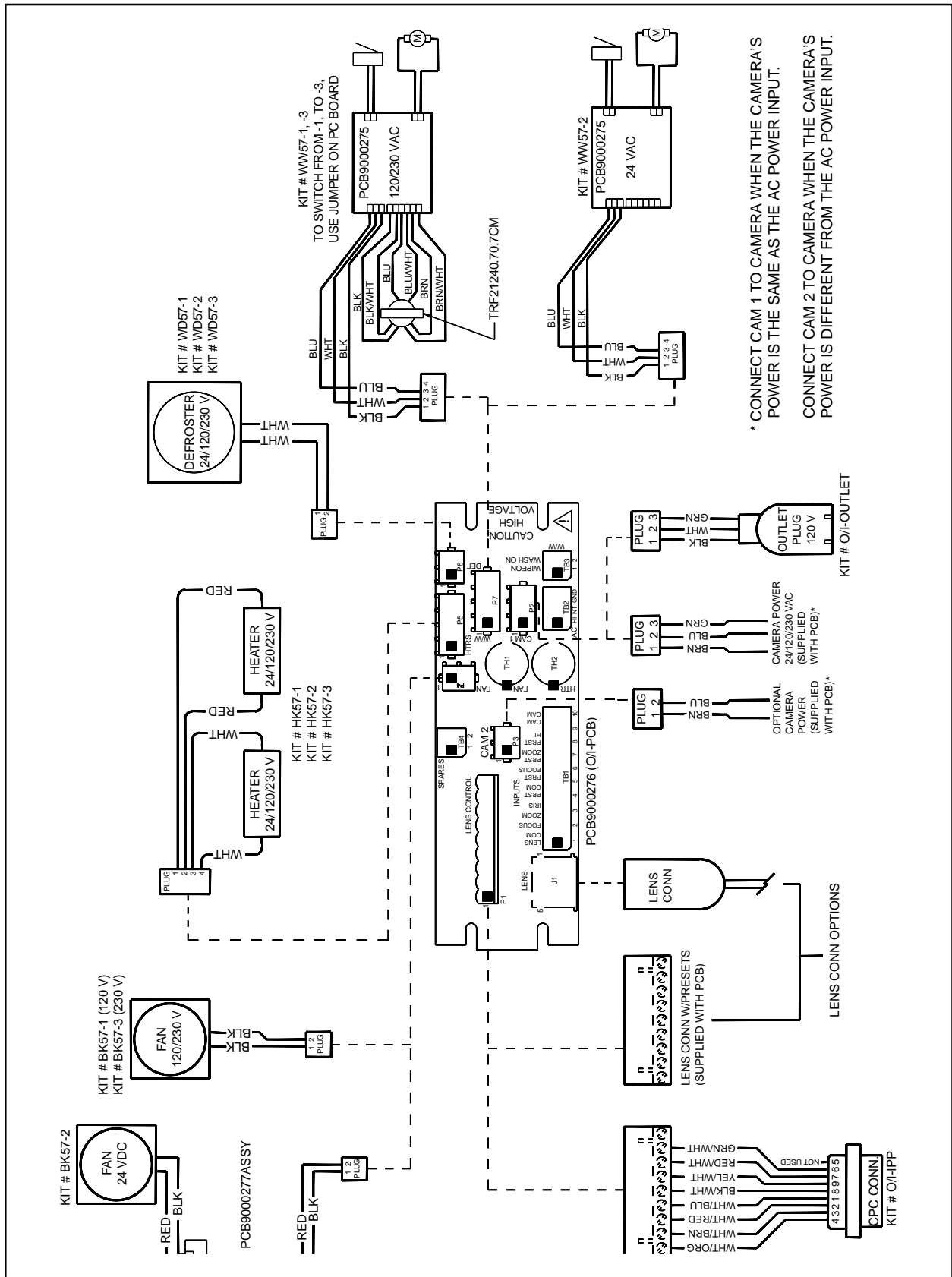

Figure 2. TC9346A Series Input Wiring Diagram

**Table A. 24 VAC Wiring Distances**

The following are the recommended maximum distances for 24 VAC applications and are calculated with a 10-percent voltage drop. (Ten percent is generally the maximum allowable voltage drop for AC-powered devices.)

EXAMPLE: An enclosure that requires 80 vA and is installed 35 feet (10 m) from the transformer would require a minimum wire gauge of 20 AWG.

NOTE: Distances are calculated in feet; values in parentheses are meters.

	Wire Gauge					
	20	18	16	14	12	10
10	283 (86)	451 (137)	716 (218)	1142 (348)	1811 (551)	2880 (877)
20	141 (42)	225 (68)	358 (109)	571 (174)	905 (275)	1440 (438)
30	94 (28)	150 (45)	238 (72)	380 (115)	603 (183)	960 (292)
40	70 (21)	112 (34)	179 (54)	285 (86)	452 (137)	720 (219)
50	56 (17)	90 (27)	143 (43)	228 (69)	362 (110)	576 (175)
60	47 (14)	75 (22)	119 (36)	190 (57)	301 (91)	480 (146)
70	40 (12)	64 (19)	102 (31)	163 (49)	258 (78)	411 (125)
80	35 (10)	56 (17)	89 (27)	142 (43)	226 (68)	360 (109)
90	31 (9)	50 (15)	79 (24)	126 (38)	201 (61)	320 (97)
100	28 (8)	45 (13)	71 (21)	114 (34)	181 (55)	288 (87)
110	25 (7)	41 (12)	65 (19)	103 (31)	164 (49)	261 (79)
120	23 (7)	37 (11)	59 (17)	95 (28)	150 (45)	240 (73)
130	21 (6)	34 (10)	55 (16)	87 (26)	139 (42)	221 (67)
140	20 (6)	32 (9)	51 (15)	81 (24)	129 (39)	205 (62)
150	18 (5)	30 (9)	47 (14)	76 (23)	120 (36)	192 (58)
160	17 (5)	28 (8)	44 (13)	71 (21)	113 (34)	180 (54)
170	16 (4)	26 (7)	42 (12)	67 (20)	106 (32)	169 (51)
180	15 (4)	25 (7)	39 (11)	63 (19)	100 (30)	160 (48)
190	14 (4)	23 (7)	37 (11)	60 (18)	95 (28)	151 (46)
200	14 (4)	22 (6)	35 (10)	57 (17)	90 (27)	144 (43)

Total vA consumed

Maximum distance from transformer to load

---

---

## 4.0 OPERATION

---

---

If your enclosure has a thermostatically controlled blower, the thermostat is set to turn the fan on between 77° and 93°F (25° and 34°C) and to turn the fan off between 62° and 78°F (17° and 26°C).

If your enclosure has thermostatically controlled heaters or defroster, the thermostat is set to turn them on between 42° and 58°F (6° and 14°C) and to turn them off between 72° and 88°F (22° and 31°C).

## 5.0 MAINTENANCE AND TROUBLESHOOTING

### 5.1 MAINTENANCE

Perform the following maintenance at regularly scheduled intervals to prolong the operational life and appearance of the equipment.

1. Clean the window with a mild non-abrasive detergent in water and a soft cloth to maintain picture clarity.
2. If your enclosure has a blower, clean the foam filters as follows:
  - a. On the bottom front of the enclosure, remove the two screws in the vent grill.
  - b. Remove the vent grill and take out the filters.
  - c. Clean the filters with warm water and mild detergent, dry thoroughly, and replace them in the grill.
  - d. Reinstall the vent grill.

To order replacement filters, use the part number EH550010045.

### 5.2 TROUBLESHOOTING

If your enclosure has the optional circuit board (O/I-PCB) and you need to troubleshoot it, Figures 3 through 5 show the wiring, component locations, and layout of traces.

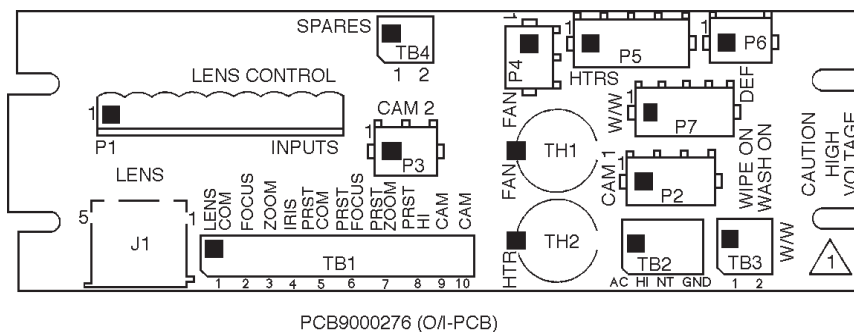

**Figure 3.** Component Locations for Optional Circuit Board

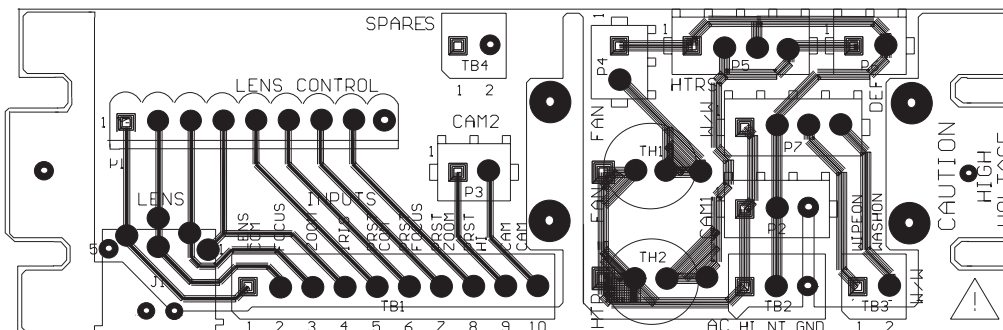

**Figure 4.** Layout of Traces on Optional Circuit Board

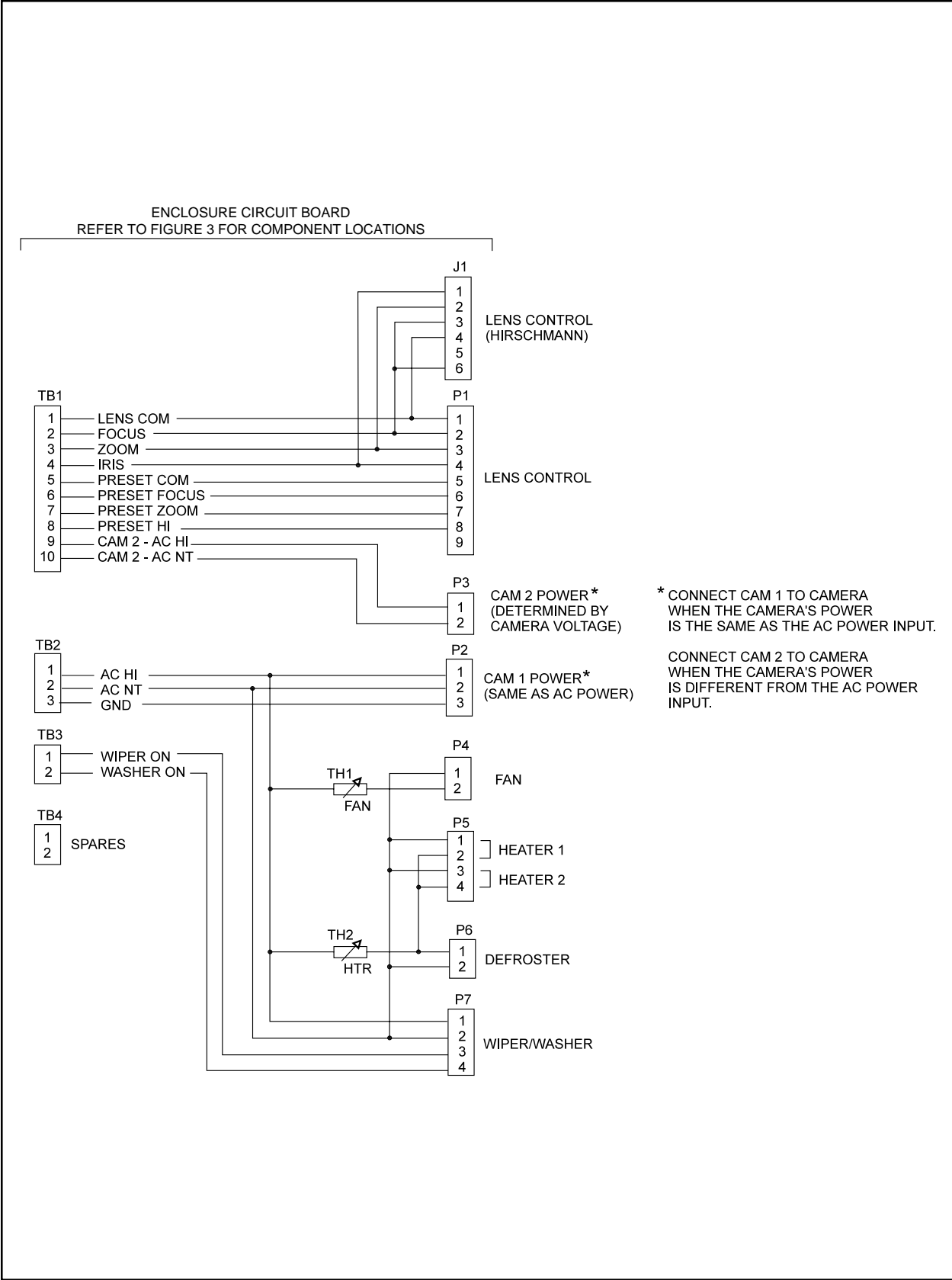

Figure 5. Wiring Diagram for Optional Circuit Board (O/I-PCB)

---

---

## 6.0 SPECIFICATIONS

---

---

### ELECTRICAL

Input Voltage: 24, 120 or 230 VAC, 50/60 Hz

Electrical Connections: One each of the following when equipped with optional circuit board (O/I-PCB):

3-connector terminal block for power input  
6-pin lens connector  
9-connector terminal block for lens wiring  
10-connector terminal block for camera/lens wiring  
2-connector terminal block for spare connections  
3-pin socket for camera power input  
2-pin socket for optional camera power input  
2-pin socket for blower  
2-pin socket for defroster  
4-pin socket for heaters  
4-pin socket for wiper  
2-pin socket for wiper control

#### Input Power

Heater -1: 90 watts  
Heater -2: 50 watts  
Heater -3: 70 watts

Defroster -1, -2, -3: 30 watts

Blower-1, -3: 15 watts  
Blower -2: 10 watts

Wiper -1, -2, -3: 15 watts

### MECHANICAL

Construction: Aluminum, 0.080-inch (0.02 cm) thick (Enclosure body and lid)

Finish: Polyester vinyl powder coat

Cable Entry: Two UL-approved glands on bottom of enclosures; maximum cable diameter 0.47 inch (1.19 cm). Will accept 1/2-inch (1.27 cm) conduit without glands.

Window: Glass, 0.25-inch (0.64 cm) thick

Window Viewing Area: 3.8" H x 4.8" W (9.65 x 12.19 cm)

Camera Mounting: Removable camera sled that can be inverted to accommodate various heights of cameras and lenses

#### Max. Camera and Lens Size

TC9346A: 28" L x 7.5" W x 5.5" H (71.12 x 19.05 x 13.97 cm)  
TC9346A-1, -2, -3: 21.5" L x 6.25" W x 5.5" H (54.61 x 15.88 x 13.97 cm)

Latches: Stainless Steel

Dimensions: See Figure 6

Weight	Unit	Shipping
TC9346A:	16 lb (7.26 kg)	18 lb (8.16 kg)
TC9346A-1, -2, -3:	18 lb (8.14 kg)	20 lb (9.07 kg)

GENERAL

NEMA Rating: 3R (4 when vent cover plates are used)

iec 144 rating: IP32 (IP56 when vent cover plates are used)

Environment: Indoor/outdoor -10° to 120°F (-23° to 49°C)

*(Design and product specifications subject to change without notice.)*

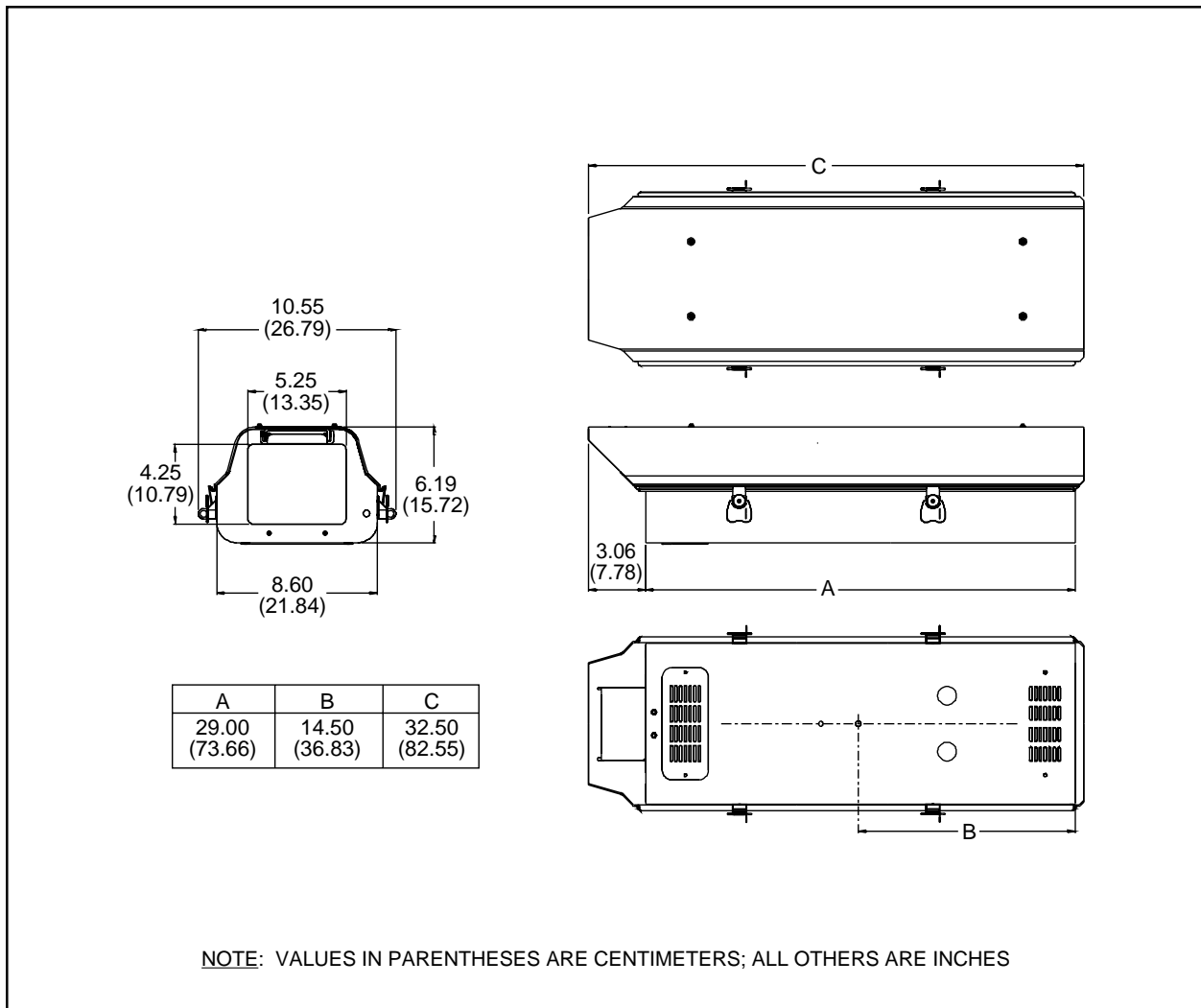

**Figure 6.** TC9346A Dimension Drawing

Bosch Security Systems, Inc.  
850 Greenfield Road  
Lancaster, PA 17601 USA  
Tel: 800-326-3270  
Fax: 1-717-735-6560  
[www.boschsecuritysystems.com](http://www.boschsecuritysystems.com)

Bosch Security Systems B.V.  
P.O. Box 80002  
5600 JB Eindhoven  
The Netherlands  
Tele +31 40 27 80000

Bosch Security Systems Pte Ltd.  
38C Jalan Pemimpin  
Singapore 577180  
Republic of Singapore  
Tel: 65 (6) 319 3486

© 2004 Bosch Security Systems GmbH  
3935 890 12912 04-33 | Updated August 10 2004 | Data subject to change without notice.

# BOSCH



## Free Manuals Download Website

<http://myh66.com>

<http://usermanuals.us>

<http://www.somanuals.com>

<http://www.4manuals.cc>

<http://www.manual-lib.com>

<http://www.404manual.com>

<http://www.luxmanual.com>

<http://aubethermostatmanual.com>

Golf course search by state

<http://golfingnear.com>

Email search by domain

<http://emailbydomain.com>

Auto manuals search

<http://auto.somanuals.com>

TV manuals search

<http://tv.somanuals.com>