

brother®

# Advanced User's Guide

MFC-8950DW  
MFC-8950DWT

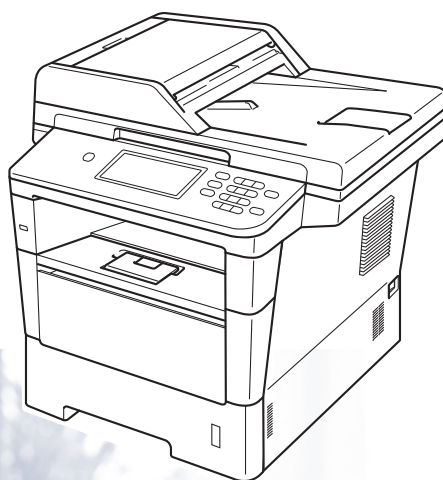

Not all models are available in all countries.

Version 0

USA/CAN

# User's Guides and where do I find them?

Which Guide?	What's in it?	Where is it?
<b>Product Safety Guide</b>	Read this Guide first. Please read the Safety Instructions before you set up your machine. See this Guide for trademarks and legal limitations.	Printed / In the Box
<b>Quick Setup Guide</b>	Follow the instructions for setting up your machine and installing the drivers and software for the operating system and connection type you are using.	Printed / In the Box
<b>Basic User's Guide</b>	Learn the basic Fax, Copy, Scan and Direct Print operations and how to replace consumables. See troubleshooting tips.	Printed / In the Box
<b>Advanced User's Guide</b>	Learn more advanced operations: Fax, Copy, security features, printing reports and performing routine maintenance.	PDF file / Installer CD-ROM / In the Box
<b>Software User's Guide</b>	Follow these instructions for Printing, Scanning, Network Scanning, Remote Setup, PC-Fax, and using the Brother ControlCenter utility.	PDF file / Installer CD-ROM / In the Box
<b>Network User's Guide</b>	This Guide provides useful information about wired and wireless network settings and security settings using the Brother machine. You can also find supported protocol information for your machine and detailed troubleshooting tips.	PDF file / Installer CD-ROM / In the Box
<b>Wi-Fi Direct™ Guide</b>	This Guide provides details on how to configure and use your Brother machine for wireless printing directly from a mobile device supporting the Wi-Fi Direct™ standard.	PDF file / Brother Solutions Center <sup>2</sup>
<b>Google Cloud Print Guide</b>	This Guide provides details on how to configure your Brother machine to a Google account and use Google Cloud Print services for printing over the Internet from devices using Gmail™ for mobile, GOOGLE DOCS™ for mobile and applications for the Chrome OS.	PDF file / Brother Solutions Center <sup>2</sup>
<b>Mobile Print/Scan Guide for Brother iPrint&amp;Scan</b>	This Guide provides useful information about printing JPEG and PDF <sup>1</sup> files from your mobile device and scanning from your Brother machine to your mobile device when connected on a Wi-Fi network.	PDF file / Brother Solutions Center <sup>2</sup>

Which Guide?	What's in it?	Where is it?
<b>Web Connect Guide</b>	This Guide provides details about how to configure and use your Brother machine to scan, load and view images and files on certain Web sites that provide these services.	PDF file / Brother Solutions Center <sup>2</sup>

<sup>1</sup> PDF printing is not supported on Windows® Phone.

<sup>2</sup> Visit us at <http://solutions.brother.com/>.

# Table of Contents

<b>1</b>	<b>General Setup</b>	<b>1</b>
	IMPORTANT NOTE.....	1
	Memory storage.....	1
	Volume settings .....	1
	Ring volume.....	1
	Beeper volume .....	2
	Speaker volume.....	2
	Automatic Daylight Saving Time.....	3
	Ecology features .....	3
	Toner Save .....	3
	Sleep Time .....	4
	Deep Sleep mode .....	4
	Quiet mode feature .....	5
	Quiet mode .....	5
	LCD screen.....	5
	Setting the backlight brightness.....	5
	Setting the Dim Timer for the backlight .....	5
	Dial Prefix .....	6
	Setting up the prefix number .....	6
	Changing the prefix number .....	6
<b>2</b>	<b>Security features</b>	<b>7</b>
	Secure Function Lock 2.0.....	7
	Setting and changing the Administrator Password.....	8
	Setting up and changing the Public user mode .....	9
	Setting up and changing restricted users .....	9
	Turning Secure Function Lock on/off.....	11
	Switching Users.....	12
	Setting Lock .....	13
	Setting up the password .....	13
	Changing your Setting Lock password .....	14
	Turning Setting Lock on/off.....	14
	Restricting dialing .....	15
	Dial pad restriction.....	15
	One Touch restriction .....	15
	Speed Dial restriction .....	15
	LDAP server restriction.....	16
<b>3</b>	<b>Sending a fax</b>	<b>17</b>
	Additional sending options.....	17
	Sending faxes using multiple settings .....	17
	Changing a 2-sided fax layout .....	18
	Contrast .....	18
	Changing Fax Resolution .....	19

Additional sending operations.....	19
Sending a fax manually .....	19
Sending a fax at the end of a conversation .....	20
Dual access .....	20
Broadcasting.....	21
Real Time Transmission.....	22
Overseas Mode .....	23
Delayed Fax .....	23
Delayed batch transmission .....	24
Checking and canceling waiting jobs.....	24
Setting your changes as the new default.....	25
Restoring all fax settings to the factory settings .....	25
Electronic cover page .....	26
Destination Display.....	28
Polling overview.....	29
Polled transmit.....	29

---

## **4 Receiving a fax 30**

Remote Fax Options.....	30
Fax Forwarding.....	30
Paging .....	31
Fax Storage .....	32
Changing Remote Fax Options .....	32
Remote retrieval .....	33
Remote fax commands.....	36
Additional receiving operations.....	37
Printing a reduced incoming fax .....	37
Duplex (2-sided) printing for Fax mode .....	37
Setting the Fax Receive Stamp .....	38
Receiving a fax at the end of a conversation.....	38
Setting the Print Density .....	39
Printing a fax from the memory .....	39
Receiving faxes into memory when the paper tray is empty .....	39
Polling overview.....	40
Polling receive .....	40

---

## **5 Dialing and storing numbers 42**

Telephone line services.....	42
Tone or Pulse (Canada only).....	42
For Fax/Tel mode only.....	42
Special line considerations .....	42
Additional dialing operations.....	44
Dialing access codes and credit card numbers .....	44
Additional ways to store numbers.....	45
Setting up Groups for Broadcasting .....	45
Options for Setting Up Groups .....	47
Changing Group numbers .....	48
Deleting Group numbers .....	49

<b>6</b>	<b>Printing reports</b>	<b>50</b>
	Fax reports.....	50
	Transmission Verification Report.....	50
	Fax Journal (Activity Report) .....	50
	Reports .....	51
	How to print a report.....	51
<b>7</b>	<b>Making copies</b>	<b>52</b>
	Copy settings .....	52
	Stop copying .....	52
	Improving copy quality .....	52
	Enlarging or reducing the image copied .....	53
	Duplex (2-sided) Copying .....	54
	Tray selection .....	55
	Adjusting Brightness and Contrast .....	56
	Sorting copies.....	56
	Making N in 1 copies (page layout) .....	57
	2 in 1 ID Copy.....	59
	Setting your changes as the new default.....	60
	Restoring all copy settings to the factory settings .....	60
	Setting your favorites.....	60
<b>A</b>	<b>Routine maintenance</b>	<b>62</b>
	Cleaning and checking the machine.....	62
	Cleaning the outside of the machine .....	63
	Cleaning the scanner.....	64
	Cleaning the corona wire .....	65
	Cleaning the drum unit .....	67
	Cleaning the paper pick-up rollers.....	71
	Checking the Page Counters.....	73
	Checking the remaining life of parts .....	73
	Replacing periodic maintenance parts.....	74
	Packing and shipping the machine .....	75
<b>B</b>	<b>Options</b>	<b>78</b>
	Options .....	78
	Optional paper tray (LT-5400) .....	79
	Memory board.....	79
	SO-DIMM Types .....	79
	Installing extra memory .....	80
<b>C</b>	<b>Glossary</b>	<b>82</b>
<b>D</b>	<b>Index</b>	<b>86</b>

## IMPORTANT NOTE

- Most of the illustrations in this User's Guide show the MFC-8950DW.

## Memory storage

Your menu settings are stored permanently, and in the event of a power failure will *not* be lost. Temporary settings (for example, Contrast and Overseas Mode) *will* be lost. Also, during a power failure the machine will retain the date and time and programmed fax timer jobs (for example, Delayed Fax) for approximately 60 hours. Other fax jobs in the machine's memory will not be lost.

## Volume settings

### Ring volume

---

You can choose a range of ring volume levels, from **High** to **Off**.

- 1 Press **Menu**.
- 2 Press **▲** or **▼** to display **General Setup**. Press **General Setup**.
- 3 Press **▲** or **▼** to display **Volume**. Press **Volume**.
- 4 Press **Ring**.
- 5 Press **Low**, **Med**, **High** or **Off**.
- 6 Press **Stop/Exit**.

## Beeper volume

When the beeper is on, the machine will beep when you press a key, make a mistake, or after you send or receive a fax. You can choose a range of volume levels, from **High** to **Off**.



- 1 Press **Menu**.
- 2 Press **▲** or **▼** to display **General Setup**.  
Press **General Setup**.
- 3 Press **▲** or **▼** to display **Volume**.  
Press **Volume**.
- 4 Press **Beeper**.
- 5 Press **Low**, **Med**, **High** or **Off**.
- 6 Press **Stop/Exit**.

## Speaker volume

You can choose a range of speaker volume levels, from **High** to **Off**.

- 1 Press **Menu**.
- 2 Press **▲** or **▼** to display **General Setup**.  
Press **General Setup**.
- 3 Press **▲** or **▼** to display **Volume**.  
Press **Volume**.
- 4 Press **Speaker**.
- 5 Press **Low**, **Med**, **High** or **Off**.
- 6 Press **Stop/Exit**.

You can also temporarily adjust the speaker volume by pressing **Hook**.

- 1 Press **Hook** on the control panel.
- 2 Press **◀** or **▶** on the Touchscreen to display **Volume**.
- 3 Press **Volume**.
- 4 Press  to decrease or  to increase the speaker volume level. Each button press changes the volume to the next setting.
- 5 Press **Hook** on the control panel.



## Automatic Daylight Saving Time

You can set the machine to change automatically for Daylight Saving Time. It will set itself forward one hour in the Spring, and back one hour in the Fall.

- 1 Press **Menu**.
- 2 Press **▲** or **▼** to display **Initial Setup**.  
Press **Initial Setup**.
- 3 Press **▲** or **▼** to display **Date&Time**.  
Press **Date&Time**.
- 4 Press **Auto Daylight**.
- 5 Press **On** or **Off**.
- 6 Press **Stop/Exit**.

## Ecology features

### Toner Save

You can save toner using this feature. When you set Toner Save to **On**, print appears lighter. The default setting is **Off**.

- 1 Press **Menu**.
- 2 Press **▲** or **▼** to display **General Setup**.  
Press **General Setup**.
- 3 Press **▲** or **▼** to display **Ecology**.  
Press **Ecology**.
- 4 Press **Toner Save**.
- 5 Press **On** or **Off**.
- 6 Press **Stop/Exit**.



#### Note

We do not recommend Toner Save for printing Photo or Gray Scale images.

## Sleep Time

The Sleep mode setting can reduce power consumption. When the machine is in Sleep mode (Power Save mode) it acts as though it is turned off. The machine will wake up and start printing when it receives a print job.

You can choose how long the machine must be idle before it goes into Sleep mode. The timer will restart if any operation is carried out on the machine, such as receiving a fax or a print job. The default setting is 3 minutes.

When the machine goes into Sleep mode, the LCD backlight turns off.

- 1 Press **Menu**.
- 2 Press **▲** or **▼** to display **General Setup**.  
Press **General Setup**.
- 3 Press **▲** or **▼** to display **Ecology**.  
Press **Ecology**.
- 4 Press **Sleep Time**.
- 5 Using the dial pad on the Touchscreen, enter the length of time (0-90 minutes) the machine will remain idle before entering Sleep mode.  
Press **OK**.
- 6 Press **Stop/Exit**.

## Deep Sleep mode

If the machine is in Sleep mode and does not receive any jobs for a certain length of time, the machine will go into Deep Sleep mode automatically. Deep Sleep mode uses less power than Sleep mode. The machine will wake up when it receives a fax or a print job.

When the machine is in Deep Sleep mode, the LCD backlight is Off and the Home key is dimmed.

If a wireless network is enabled, the machine will not enter Deep Sleep mode.

For the procedure to disable the wireless network >> *Network User's Guide: Control panel setup*

If the machine has secure print data it will not enter Deep Sleep mode.

## Quiet mode feature

### Quiet mode

---

The Quiet mode setting can reduce noise while printing. When Quiet Mode is turned On, the print speed becomes slower. The default setting is Off.

- 1 Press Menu.
- 2 Press ▲ or ▼ to display General Setup.  
Press General Setup.
- 3 Press ▲ or ▼ to display Quiet Mode.  
Press Quiet Mode.
- 4 Press On or Off.
- 5 Press **Stop/Exit**.

## LCD screen

### Setting the backlight brightness

---

You can adjust the brightness of the LCD backlight. If you are having difficulty reading the LCD, try changing the brightness setting.

- 1 Press Menu.
- 2 Press ▲ or ▼ to display General Setup.  
Press General Setup.
- 3 Press ▲ or ▼ to display LCD Settings.  
Press LCD Settings.
- 4 Press Backlight.
- 5 Press Light, Med or Dark.
- 6 Press **Stop/Exit**.

### Setting the Dim Timer for the backlight

---

You can set how long the LCD backlight stays on after you go back to the Ready screen.

- 1 Press Menu.
- 2 Press ▲ or ▼ to display General Setup.  
Press General Setup.
- 3 Press ▲ or ▼ to display LCD Settings.  
Press LCD Settings.
- 4 Press Dim Timer.
- 5 Press 10 Secs, 20 Secs, 30 Secs or Off.
- 6 Press **Stop/Exit**.

## Dial Prefix

The Dial Prefix setting will automatically dial a predefined number before every fax number you dial. For example: If your telephone system requires a 9 to dial an outside number use this setting to automatically dial 9 for every fax you send.

### Setting up the prefix number

- 1 Press Menu.
- 2 Press ▲ or ▼ to display Initial Setup.  
Press Initial Setup.
- 3 Press ▲ or ▼ to display Dial Prefix.  
Press Dial Prefix.
- 4 Do one of the following:
  - If you want to set the dial prefix feature to on, press On. Go to step 5.
  - If you want to set the dial prefix feature to off, press Off. Go to step 7.
- 5 Press Dial Prefix.
- 6 Enter the prefix number (up to 5 digits) by pressing the buttons on the Touchscreen.  
Press OK.



#### Note

- You can use the numbers and symbols 0 to 9, #, and \*. (You cannot use ! with any other numbers or symbols.)
- If your telephone system requires a time break recall (hookflash), press ! on the Touchscreen.
- (Canada only) If pulse dialing mode is on, # and \* are not available to use.

- 7 Press **Stop/Exit**.

### Changing the prefix number

- 1 Press Menu.
- 2 Press ▲ or ▼ to display Initial Setup.  
Press Initial Setup.
- 3 Press ▲ or ▼ to display Dial Prefix.  
Press Dial Prefix.
- 4 Press On (or Off).  
You can turn off the prefix number by pressing Off. The prefix number will remain off until you press On.
- 5 Press Dial Prefix.
- 6 Do one of the following using the buttons on the Touchscreen.
  - To change the prefix number, press ◀ or ▶ to position the cursor under the digit to be deleted and press the Back Space button . Then press the correct digit.  
  
Repeat until the prefix number is correct, and then press OK.
  - To exit without making a change, press OK.



#### Note

- You can use the numbers and symbols 0 to 9, #, and \*. (You cannot use ! with any other numbers or symbols.)
- If your telephone system requires a time break recall (hookflash), press ! on the Touchscreen.
- (Canada only) If pulse dialing mode is on, # and \* are not available to use.

- 7 Press **Stop/Exit**.

## Secure Function Lock 2.0

Secure Function Lock lets you restrict Public access to the following machine functions:

- Fax Tx
- Fax Rx
- Copy
- Scan <sup>1</sup>
- Direct Print
- Print <sup>2</sup>
- Page Limit <sup>3</sup>
- Web Connect

<sup>1</sup> Scan includes scan jobs via Brother iPrint&Scan.

<sup>2</sup> Print includes print jobs via Google Cloud Print and Brother iPrint&Scan.

<sup>3</sup> Page Limit is configured using Web Based Management.

This feature also prevents users from changing the default settings of the machine by limiting access to the Menu settings.

Before using the security features you must first enter an administrator password.

Access to restricted operations can be enabled by creating a restricted user. Restricted users must enter a password to use the machine.

Make a careful note of your password. If you forget it, you will have to reset the password stored in the machine. For information about how to reset the password call Brother Customer Service.



### Note

- Secure Function Lock can be set manually at the control panel, or by using Web Based Management or BRAdmin Professional 3 (Windows<sup>®</sup> only). We recommend using Web Based Management or BRAdmin Professional 3 (Windows<sup>®</sup> only) to configure this feature. (See Network User's Guide.)
- Only administrators can set limitations and make changes for each user.
- Polling Receive is enabled only when both Fax Tx and Fax Rx are enabled.

## Setting and changing the Administrator Password

### Setting up the password

The password you set in these steps is for the administrator. This password is used to set up users and to turn the Secure Function Lock on or off. (See *Setting up and changing restricted users* >> page 9 and *Turning Secure Function Lock on/off* >> page 11.)



#### Note

Make a careful note of the administrator password. If you enter the wrong password, the LCD will show `Wrong Password`. Re-enter the correct password. If you forget it, please call Brother Customer Service.

- 1 Press **Menu**.
- 2 Press **▲** or **▼** to display `General Setup`.  
Press `General Setup`.
- 3 Press **▲** or **▼** to display `Security`.  
Press `Security`.
- 4 Press `Function Lock`.
- 5 Enter a four-digit number for the password by pressing the buttons on the Touchscreen.  
Press `OK`.
- 6 Re-enter the password when the LCD shows `Verify:.`  
Press `OK`.
- 7 Press **Stop/Exit**.

### Changing the password

- 1 Press **Menu**.
- 2 Press **▲** or **▼** to display `General Setup`.  
Press `General Setup`.
- 3 Press **▲** or **▼** to display `Security`.  
Press `Security`.
- 4 Press `Function Lock`.
- 5 Press `Set Password`.
- 6 Enter the registered four-digit password by pressing the buttons on the Touchscreen.  
Press `OK`.
- 7 Enter a four-digit number for the new password by pressing the buttons on the Touchscreen.  
Press `OK`.
- 8 Re-enter the password when the LCD shows `Verify:.`  
Press `OK`.
- 9 Press **Stop/Exit**.

## Setting up and changing the Public user mode

Public user mode restricts the functions that are available for Public users. Public users do not need to enter a password to access the features made available through this setting. You can set up one Public user.

- 1 Press **Menu**.
- 2 Press **▲** or **▼** to display **General Setup**.  
Press **General Setup**.
- 3 Press **▲** or **▼** to display **Security**.  
Press **Security**.
- 4 Press **Function Lock**.
- 5 Press **Setup ID**.
- 6 Enter the administrator password by pressing the buttons on the Touchscreen.  
Press **OK**.
- 7 Press **▲** or **▼** to display **Public**.  
Press **Public**.
- 8 Do one of the following:
  - To set up the Public user, press **Enable** or **Disable** for each operation, as follows: Press **Fax Tx**. Then press **Enable** or **Disable**. After you have set **Fax Tx**, repeat these steps for **Fax Rx**, **Copy**, **Scan**, **Direct Print**, **Print and Web Connect**.
  - To change the Public user settings, press **▲** or **▼** to display the setting you want to change. Press the setting and press **Enable** or **Disable**. Repeat this step until you finish changing settings.
- 9 Press **Stop/Exit**.

## Setting up and changing restricted users

You can set up users with a password and restrict the functions that are available to them. You can set up more advanced restrictions, such as by page count or PC user login name, through Web Based Management or BRAdmin Professional 3 (Windows® only). (See Network User's Guide.) You can set up to 25 restricted users.

### Setting up restricted users

- 1 Press **Menu**.
- 2 Press **▲** or **▼** to display **General Setup**.  
Press **General Setup**.
- 3 Press **▲** or **▼** to display **Security**.  
Press **Security**.
- 4 Press **Function Lock**.
- 5 Press **Setup ID**.
- 6 Enter the four-digit administrator password by pressing the buttons on the Touchscreen.  
Press **OK**.
- 7 Press **▲** or **▼** to display **UserXX**.  
Press **UserXX**.
- 8 Enter the user name by pressing the buttons on the Touchscreen. (See Basic User's Guide: *Entering text*.)  
Press **OK**.
- 9 Enter a four-digit user password by pressing the buttons on the Touchscreen.  
Press **OK**.

- 10 To set up a restricted user, press **Enable** or **Disable** for each operation, as follows: Press **Fax Tx**. Then press **Enable** or **Disable**. After you have set **Fax Tx**, repeat these steps for **Fax Rx**, **Copy**, **Scan**, **Direct Print**, **Print and Web Connect**.
- 11 Press  and repeat steps 7 to 10 for entering each additional user and password.
- 12 Press **Stop/Exit**.

**Note**

You cannot use the same name as another user's name.

### Changing user name, password or settings for restricted users

- 1 Press **Menu**.
- 2 Press **▲** or **▼** to display **General Setup**. Press **General Setup**.
- 3 Press **▲** or **▼** to display **Security**. Press **Security**.
- 4 Press **Function Lock**.
- 5 Press **Setup ID**.
- 6 Enter the four-digit administrator password by pressing the buttons on the Touchscreen. Press **OK**.
- 7 Press **▲** or **▼** to display the existing restricted user you want to change. Press the user name.
- 8 Press **Change**. To change the user name, enter a new user name by pressing the buttons on the Touchscreen. (See Basic User's Guide: *Entering text*.) Press **OK**.

- 9 To change the password, enter a new four-digit user password by pressing the buttons on the Touchscreen. Press **OK**.
- 10 To change a restricted user's settings, press **▲** or **▼** to display the setting you want to change. Press the setting and then press **Enable** or **Disable**. Repeat this step until you are finished making changes.
- 11 Press **Stop/Exit**.

**Note**

You cannot use the same name as another user's name.

### Reset existing restricted users

- 1 Press **Menu**.
- 2 Press **▲** or **▼** to display **General Setup**. Press **General Setup**.
- 3 Press **▲** or **▼** to display **Security**. Press **Security**.
- 4 Press **Function Lock**.
- 5 Press **Setup ID**.
- 6 Enter the four-digit administrator password by pressing the buttons on the Touchscreen. Press **OK**.
- 7 Press **▲** or **▼** to display the existing restricted user you want to reset. Press the user name.
- 8 Press **Reset**.
- 9 Press **Yes** to reset the existing restricted user.
- 10 Press **Stop/Exit**.



## Turning Secure Function Lock on/off

---

### Turning Secure Function Lock on

- 1 Press **Menu**.
- 2 Press **▲** or **▼** to display **General Setup**.  
Press **General Setup**.
- 3 Press **▲** or **▼** to display **Security**.  
Press **Security**.
- 4 Press **Function Lock**.
- 5 Press **Lock Off⇒On**.
- 6 Enter the registered four-digit administrator password by pressing the buttons on the Touchscreen.  
Press **OK**.

### Turning Secure Function Lock off

- 1 Press **Public** or **xxxxxx** (where **xxxxxx** is the user's name).
- 2 Press **Lock On⇒Off**.
- 3 Enter the registered four-digit administrator password by pressing the buttons on the Touchscreen.  
Press **OK**.



#### Note

---

If you enter the wrong password, the LCD will show **Wrong Password**. Re-enter the correct password.

---

## Switching Users

---

This setting allows you to switch between registered restricted users or Public mode when Secure Function Lock is turned on.

### Changing to the restricted user mode

- 1 Press `Public` or `xxxxxx` (where `xxxxxx` is the user's name).  
Press `Change User`.
- 2 Press `▲` or `▼` to display your user name.
- 3 Press your user name.
- 4 Enter the registered four-digit user password by pressing the buttons on the Touchscreen.  
Press `OK`.



### Note

---

- If the current ID is restricted for the function you want to use, `Access Denied` will appear on the LCD.
  - If your ID has set page limit restrictions and already reached the maximum number of pages, the LCD will show `Limit Exceeded` when you print data. Contact your administrator to check your Secure Function Lock Settings.
- 

### Changing to the Public mode

- 1 Press `xxxxxx`. (where `xxxxxx` is the user's name.)
- 2 Press `Go to Public`.



### Note

---

- After a restricted user has finished using the machine, it will return to the Public setting within one minute.
  - If the function you want to use is restricted for all users, `Access Denied` will appear on the LCD and the machine will go back to the Ready mode. You cannot access the function you want to use. Contact your administrator to check your Secure Function Lock Settings.
-

## Setting Lock

Setting Lock lets you set a password to stop other people from accidentally changing your machine settings.

Make a careful note of your password. If you forget it, you will have to reset the passwords stored in the machine. Please call your administrator or Brother Customer Service.

While Setting Lock is On, you cannot access the **Menu** button or edit the numbers you stored in the **Address Book**. You can still use the **Address Book** button to send faxes and E-mail messages to previously stored numbers.

Machine settings cannot be changed through the **Remote Setup** utility while Setting Lock is On.

## Setting up the password

- 1 Press **Menu**.
- 2 Press **▲** or **▼** to display **General Setup**.  
Press **General Setup**.
- 3 Press **▲** or **▼** to display **Security**.  
Press **Security**.
- 4 Press **Setting Lock**.
- 5 Enter a four-digit number for the password by pressing the buttons on the Touchscreen.  
Press **OK**.
- 6 Re-enter the password when the LCD shows **Verify:.**  
Press **OK**.
- 7 Press **Stop/Exit**.

## Changing your Setting Lock password

- 1 Press **Menu**.
- 2 Press **▲** or **▼** to display **General Setup**.  
Press **General Setup**.
- 3 Press **▲** or **▼** to display **Security**.  
Press **Security**.
- 4 Press **Setting Lock**.
- 5 Press **Set Password**.
- 6 Enter the registered four-digit password by pressing the buttons on the Touchscreen.  
Press **OK**.
- 7 Enter a four-digit number for the new password by pressing the buttons on the Touchscreen.  
Press **OK**.
- 8 Re-enter the password when the LCD shows **Verify:**.  
Press **OK**.
- 9 Press **Stop/Exit**.

## Turning Setting Lock on/off

If you enter the wrong password when following the instructions below, the LCD will show **Wrong Password**. Re-enter the correct password.

### Turning Setting Lock on

- 1 Press **Menu**.
- 2 Press **▲** or **▼** to display **General Setup**.  
Press **General Setup**.
- 3 Press **▲** or **▼** to display **Security**.  
Press **Security**.
- 4 Press **Setting Lock**.
- 5 Press **Lock Off⇒On**.
- 6 Enter the registered four-digit administrator password by pressing the buttons on the Touchscreen.  
Press **OK**.

The LCD will show locks on the **Setting Lock** and **Menu** buttons.



### Turning Setting Lock off

- 1 Press **Setting Lock** on the LCD.
- 2 Enter the registered four-digit administrator password by pressing the buttons on the Touchscreen.  
Press **OK**.

## Restricting dialing

This feature is to prevent users from sending a fax or call to a wrong number by mistake. You can set the machine to restrict dialing when you use the dial pad, One Touch, Speed Dial and LDAP search.

If you choose **Off**, the machine does not restrict the dialing method.

If you choose **Enter # twice**, the machine will prompt you to re-enter the number, and then if you re-enter the same number correctly, the machine will start dialing. If you re-enter the wrong number, the LCD will show an error message.

If you choose **On**, the machine will restrict all fax sending and outbound calls for that dialing method.

### Dial pad restriction

- 1 Press **Menu**.
- 2 Press **▲** or **▼** to display **Fax**. Press **Fax**.
- 3 Press **▲** or **▼** to display **Dial Restrict..**  
Press **Dial Restrict..**
- 4 Press **Dial Pad**.
- 5 Press **Enter # twice**, **On** or **Off**.
- 6 Press **Stop/Exit**.

### One Touch restriction

- 1 Press **Menu**.
- 2 Press **▲** or **▼** to display **Fax**. Press **Fax**.
- 3 Press **▲** or **▼** to display **Dial Restrict..**  
Press **Dial Restrict..**
- 4 Press **One Touch Dial**.
- 5 Press **Enter # twice**, **On** or **Off**.
- 6 Press **Stop/Exit**.

### Speed Dial restriction

- 1 Press **Menu**.
- 2 Press **▲** or **▼** to display **Fax**. Press **Fax**.
- 3 Press **▲** or **▼** to display **Dial Restrict..**  
Press **Dial Restrict..**
- 4 Press **Speed Dial**.
- 5 Press **Enter # twice**, **On** or **Off**.
- 6 Press **Stop/Exit**.

## LDAP server restriction

---

- 1 Press Menu.
- 2 Press ▲ or ▼ to display Fax.  
Press Fax.
- 3 Press ▲ or ▼ to display  
Dial Restrict..  
Press Dial Restrict..
- 4 Press LDAP Server.
- 5 Press Enter # twice, On Or Off.
- 6 Press **Stop/Exit**.



### Note

---

- The Enter # twice setting will not work if you use an external phone or press **Hook** before entering the number. You will not be asked to re-enter the number.
  - You can not restrict dialing when you use **Redial/Pause**.
  - If you chose On or Enter # twice, you cannot use the Broadcasting feature and cannot combine quick dial numbers when dialing.
-

# 3

## Sending a fax

### Additional sending options

### Sending faxes using multiple settings

Before you send a fax, you can change any combination of these settings:

- Duplex Fax
- Contrast
- Fax Resolution
- Real Time TX
- Overseas Mode
- Delayed Fax
- Batch TX
- Coverpage Message
- Coverpage Setup

- 1 Press Fax on the Touchscreen.



The LCD shows:

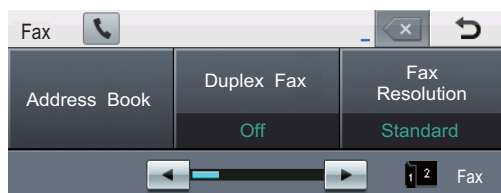

- 2 Press ◀ or ▶ to display a setting you want to change and press the setting, then press the option you want.

- 3 Do one of the following:
  - Repeat step 2 to change more settings.
  - If you are finished choosing settings, go to the next step for sending your fax.





#### Note

- Most settings are temporary and the machine returns to its default settings after you send a fax.
- You can save some of the settings you use most often by setting them as the default. These settings will stay until you change them again. (See *Setting your changes as the new default* ►► page 25.)



## Changing a 2-sided fax layout

You need to choose the duplex scanning format before you send a 2-sided fax. The format you choose will depend on the layout of your 2-sided document.

- 1 Press **Fax**.
- 2 Press **◀** or **▶** to display **Duplex Fax**. Press **Duplex Fax**.
- 3 Do one of the following:
  - If your document is flipped on the Long edge, press  
**DuplexScan : LongEdge**.

Long edge	
Portrait	Landscape
	

- If your document is flipped on the Short edge, press  
**DuplexScan : ShortEdge**.

Short edge	
Portrait	Landscape
	

## Contrast

For most documents the default setting of **Auto** will give the best results.

**Auto** automatically chooses the suitable contrast for your document.

If your document is very light or very dark, changing the contrast may improve the quality of the fax.

Use **Dark** to make the faxed document lighter.

Use **Light** to make the faxed document darker.

- 1 Press **Fax**.
- 2 Press **◀** or **▶** to display **Contrast**. Press **Contrast**.
- 3 Press **Auto**, **Light** or **Dark**.



### Note

Even if you choose **Light** or **Dark**, the machine will send the fax using the **Auto** setting if you choose **Photo** as the Fax Resolution.



## Changing Fax Resolution

The quality of a fax can be improved by changing the Fax Resolution. Resolution can be changed for the next fax.

- 1 Press **Fax**.
- 2 Press **◀** or **▶** to display Fax Resolution. Press **Fax Resolution**.
- 3 Press **Standard**, **Fine**, **S. Fine** or **Photo**.



### Note

You can choose four different resolution settings.

Black & white	
Standard	Suitable for most typed documents.
Fine	Good for small print and transmits a little slower than Standard resolution.
S. Fine	Good for small print or artwork and transmits slower than Fine resolution.
Photo	Use when the document has varying shades of grey or is a photograph. This has the slowest transmission time.

## Additional sending operations

### Sending a fax manually

#### Manual transmission

Manual transmission lets you hear the dialing, ringing and fax-receiving tones while sending a fax.

- 1 Press **Fax**.
- 2 Load your document.
- 3 Press **Hook** and listen for a dial tone.
- 4 Dial the fax number you want to call.
- 5 When you hear the fax tones, press **Start**.
  - If you are using the scanner glass, press **Send**.

## Sending a fax at the end of a conversation

---

At the end of a conversation you can send a fax to the other party before you both hang up.

- 1 Ask the other party to wait for fax tones (beeps) and then to press the **Start** or **Send** key before hanging up.
- 2 Load your document.
- 3 Press **Start**.
  - If you are using the scanner glass, press **Send**.
- 4 Replace the handset of an external telephone.

## Dual access

---

You can dial a number and start scanning the fax into memory—even when the machine is sending from memory, receiving faxes or printing PC data. The LCD will show the new job number.

The number of pages you can scan into the memory will vary depending on the data that is printed on them.



### Note

---

If you get an **Out of Memory** message while scanning the first page of a fax, press **Stop/Exit** to cancel scanning. If you get an **Out of Memory** message while scanning a subsequent page, you can press **Start** to send the pages scanned so far, or press **Stop/Exit** to cancel the operation.

---

## Broadcasting

Broadcasting lets you send the same fax message to more than one fax number. You can include Groups, One Touch, Speed Dial numbers and up to 50 manually dialed numbers in the same broadcast.

You can broadcast up to 382 different numbers. This will depend on how many Groups, access codes or credit card numbers you have saved, and how many delayed or stored faxes are in the memory.

### Before you begin the broadcast

One Touch and Speed Dial numbers must be stored in the machine's memory before they can be used in a broadcast. (See Basic User's Guide: *Storing One Touch Dial numbers* and *Storing Speed Dial numbers*.)

Group numbers must also be stored in the machine's memory before they can be used in a broadcast. Group numbers include many previously stored One Touch Dial and Speed Dial numbers for easier dialing. (See *Setting up Groups for Broadcasting* >> page 45.)

## How to broadcast a fax



### Note

To help you choose numbers easily, press (Search).

- 1 Press **Fax**.
- 2 Load your document.
- 3 Press **◀** or **▶** to display **Broadcasting**. Press **Broadcasting**.
- 4 You can add numbers to the broadcast in the following ways:
  - Press **Manual** and enter a number by pressing the buttons on the Touchscreen. (See Basic User's Guide: *How to dial*.)  
Press **OK**.
  - Press **Address Book**. Press **#001 A** to search by Alphabetical Order or Numerical Order. Put a check in the check box beside each number you want to include in the broadcast.  
Press **OK**.



### Note

One Touch Dial numbers begin with \*.  
Speed Dial numbers begin with #.

- 5 After you have entered all the fax numbers by repeating step 4, press **OK**.
- 6 Press **Start**.

After the broadcast is finished the machine will print a broadcast report to let you know the results.



### Note

The scan profile of the One Touch, Speed Dial or Group number you chose *first* will be applied to the broadcast.

## Canceling a Broadcast in progress

While broadcasting you can cancel the fax currently being sent or the whole broadcast job.

- 1 Press **Stop/Exit**.
- 2 Do one of the following:
  - To cancel the entire broadcast, press **Entire Broadcast**. Go to step 3.
  - To cancel the current job, press the button that displays the number being dialed. Go to step 4.
  - To exit without canceling, press **Stop/Exit**.
- 3 When the LCD asks if you want to cancel the entire broadcast, do one of the following:
  - Press **Yes** to confirm.
  - To exit without canceling, press **No** or **Stop/Exit**.
- 4 Do one of the following:
  - To cancel the current job, press **Yes**.
  - To exit without canceling, press **No** or **Stop/Exit**.

## Real Time Transmission

When you are sending a fax, the machine will scan the documents into the memory before sending it. Then, as soon as the telephone line is free, the machine will start dialing and sending.

Sometimes, you may want to send an important document immediately, without waiting for memory transmission. You can turn on **Real Time TX**.



### Note

- If the memory is full and you are sending a fax from the ADF, the machine will send the document in real time (even if **Real Time TX** is set to Off). If the memory is full, faxes from the scanner glass cannot be sent until you clear some of the memory.
- In **Real Time Transmission**, the automatic redial feature does not work when using the scanner glass.

- 1 Press **Fax**.
- 2 Load your document.
- 3 Press **◀** or **▶** to display **Real Time TX**. Press **Real Time TX**.
- 4 Press **On**.

## Overseas Mode

---

If you are having difficulty sending a fax overseas due to a bad connection, then turning on Overseas Mode may help.

This is a temporary setting, and will only be active for your next fax.

- 1 Press **Fax**.
- 2 Load your document.
- 3 Press **◀** or **▶** to display **Overseas Mode**. Press **Overseas Mode**.
- 4 Press **On**.

## Delayed Fax

---

You can store up to 50 faxes in the memory to be sent within a twenty-four hour period.

- 1 Press **Fax**.
- 2 Load your document.
- 3 Press **◀** or **▶** to display **Delayed Fax**. Press **Delayed Fax**.
- 4 Press **On**.
- 5 To enter the time you want the fax to be sent, do one of the following:
  - If you have set **12h Clock** as the format in the **Date&Time** setting, enter the time (in 12-hour format) by pressing the buttons on the Touchscreen, and then press **AM** or **PM**.  
Press **OK**.
  - If you have set **24h Clock** in the **Date&Time** setting, enter the time (in 24-hour format) by pressing the buttons on the Touchscreen.  
Press **OK**.  
(For example, enter 19:45 for 7:45 PM.)



### Note

---

The number of pages you can scan into the memory depends on the amount of data printed on each page.

---

## Delayed batch transmission

Before sending the delayed faxes, your machine will help you economize by sorting all the faxes in the memory by destination and scheduled time.

All delayed faxes that are scheduled to be sent at the same time to the same fax number will be sent as one fax to save transmission time.

- 1 Press **Menu**.
- 2 Press **▲** or **▼** to display **Fax**. Press **Fax**.
- 3 Press **▲** or **▼** to display **Setup Send**. Press **Setup Send**.
- 4 Press **Batch TX**.
- 5 Press **On** (or **Off**).
- 6 Press **Stop/Exit**.

## Checking and canceling waiting jobs

Check which jobs are still waiting in the memory to be sent. If there are no jobs, the LCD will show **No Jobs Waiting**. You can cancel a fax job that is stored and waiting in the memory.

- 1 Press **Menu**.
- 2 Press **▲** or **▼** to display **Fax**. Press **Fax**.
- 3 Press **▲** or **▼** to display **Remaining Jobs**. Press **Remaining Jobs**. Jobs that are waiting will appear on the LCD.
- 4 Press **▲** or **▼** to scroll through the waiting jobs and press the job you want to cancel. Press **OK**.
- 5 Do one of the following:
  - To cancel, press **Yes**. If you want to cancel another job repeat step 4.
  - To exit without canceling, press **No**.
- 6 When you have finished canceling jobs, press **Stop/Exit**.

## Setting your changes as the new default

---

You can save the fax settings for Fax Resolution, Contrast, Real Time TX, Glass ScanSize and Coverpage Setup you use most often by setting them as the default. These settings will stay until you change them again.

- 1 Press Fax.
- 2 Press ◀ or ▶ to choose the setting you want to change, and then press the new option.  
Repeat this step for each setting you want to change.
- 3 After changing the last setting, press ◀ or ▶ to display Set New Default.  
Press Set New Default.
- 4 Press Yes.
- 5 Press **Stop/Exit**.

## Restoring all fax settings to the factory settings

---

You can restore all the fax settings you have changed to the factory settings. These settings will stay until you change them again.

- 1 Press Fax.
- 2 Press ◀ or ▶ to display Factory Reset.  
Press Factory Reset.
- 3 Press Yes.
- 4 Press **Stop/Exit**.

## Electronic cover page

This feature will *not* work unless you have programmed your Station ID. (See Quick Setup Guide.)

You can automatically send a cover page with every fax. Your cover page includes your Station ID, a comment, and the name (or number) stored in the One Touch or Speed Dial memory.

By choosing **On** you can also display the number of pages on the cover page.

You can choose one of the following preset comments.

1. Comment Off
2. Please Call
3. Urgent
4. Confidential

Instead of using one of the preset comments, you can enter two personal messages of your own, up to 27 characters long. (See Basic User's Guide: *Entering text*.)

(See *Composing your own comments* ►► page 26.)

5. (User Defined)
6. (User Defined)

## Composing your own comments

You can set up two comments of your own.

- 1 Press **Menu**.
- 2 Press **▲** or **▼** to display **Fax**. Press **Fax**.
- 3 Press **▲** or **▼** to display **Setup Send**. Press **Setup Send**.
- 4 Press **Coverpage Setting**.
- 5 Press **Coverpage Message**.
- 6 Press **5** or **6** to store your own comment.
- 7 Enter your own comment by pressing the buttons on the Touchscreen. Press **OK**.  
Press **A|@** to choose numbers, letters or special characters. (See Basic User's Guide: *Entering text*.)
- 8 Press **Stop/Exit**.



### Send a cover page for all faxes

You can set the machine to send a cover page whenever you send a fax.

- 1 Press **Fax**.
- 2 Press **◀** or **▶** to display **Coverpage Setup**.  
Press **Coverpage Setup**.
- 3 Press **On** (or **Off**).
- 4 Press the comment you want to add.
- 5 Enter two digits to show the number of pages you are sending.  
Press **OK**.  
For example, enter **0 2** for 2 pages or **0 0** to leave the number of pages blank.  
If you make a mistake, press **Clear** to back up and re-enter the number of pages.
- 6 Press **◀** or **▶** to display **Set New Default**.  
Press **Set New Default**.
- 7 Press **Yes**.
- 8 Press **Stop/Exit**.

### Using a printed cover page

If you want to use a printed cover page that you can write on, you can print the sample page and attach it to your fax.

- 1 Press **Menu**.
- 2 Press **▲** or **▼** to display **Fax**.  
Press **Fax**.
- 3 Press **▲** or **▼** to display **Setup Send**.  
Press **Setup Send**.
- 4 Press **Coverpage Setting**.
- 5 Press **Print Sample**.
- 6 Press **Start**.
- 7 After the machine prints a copy of your cover page, press **Stop/Exit**.

## Destination Display

---

The machine displays the information registered in the address book or the number you dialed to send a fax. You can set the machine to hide the destination information on the LCD.

- 1 Press **Menu**.
- 2 Press **▲** or **▼** to display **Fax**.  
Press **Fax**.
- 3 Press **▲** or **▼** to display **Setup Send**.  
Press **Setup Send**.
- 4 Press **Destination**.
- 5 Press **Hidden (or Display)**.
- 6 Press **Stop/Exit**.

## Polling overview

Polling lets you set up your machine so other people can receive faxes from you, but they pay for the call. It also lets you call somebody else's fax machine and receive a fax from it, so you pay for the call. The polling feature needs to be set up on both machines for this to work. Not all fax machines support polling.

## Polled transmit

Polled transmit lets you set up your machine to wait with a document so another fax machine can call and retrieve it.

### Setup for polled transmit

- 1 Press **Fax**.
- 2 Load your document.
- 3 Press **◀** or **▶** to display **Polled TX**.  
Press **Polled TX**.
- 4 Press **On**.
- 5 Press **Start**.  
If you are using the ADF, go to step 8.
- 6 If you are using the scanner glass, the LCD will prompt you to choose one of the following options:
  - Press **Yes** to scan another page.  
Go to step 7.
  - Press **No** or **Start** if you are finished scanning pages.
- 7 Place the next page on the scanner glass and press **Start**. Repeat step 6 for each additional page you want to scan from the scanner glass.
- 8 Your machine will automatically send the fax when it is polled.



### Note

The document will be stored and can be retrieved from any other fax machine until you delete the fax from memory.

To delete the fax from memory, press **Menu, Fax, Remaining Jobs**. (See *Checking and canceling waiting jobs* >> page 24.)

# 4

## Receiving a fax

### Remote Fax Options

Remote Fax Options let you receive faxes while you are away from the machine.

You can use *only one* Remote Fax Option at a time.

### Fax Forwarding

The Fax Forwarding feature lets you automatically forward your received faxes to another machine.

- 1 Press **Menu**.
- 2 Press **▲** or **▼** to display **Fax**.  
Press **Fax**.
- 3 Press **▲** or **▼** to display **Setup Receive**.  
Press **Setup Receive**.
- 4 Press **▲** or **▼** to display **Forward/Page/Store**.  
Press **Forward/Page/Store**.
- 5 Press **Fax Forward**.
- 6 Do one of the following:
  - Press **Manual** to enter the forwarding fax number (up to 20 characters) or E-mail address (up to 60 characters) using the buttons on the Touchscreen. (See Basic User's Guide: *Entering text*.)  
Press **OK**.
  - Press **Address Book**.  
Press **▲** or **▼** to scroll until you find the fax number or E-mail address you want your faxes to be forwarded to.  
Press the fax number or E-mail address you want to use.



### Note

- You can enter an E-mail address by pressing on the Touchscreen.
- You can display your stored numbers and E-mail addresses in alphabetical order by pressing on the Touchscreen.
- Depending on the E-mail address you choose, you will be asked for the File Type. Choose **TIFF** or **PDF** and go to step 7.
- If you choose a Group number from the Address Book, the faxes will be forwarded to multiple fax numbers.

7

Press **Backup Print:On** or **Backup Print:Off**.



### Important

If you choose **Backup Print On**, the machine will also print received faxes at your machine so you will have a copy. This is a safety feature in case there is a power failure before the fax is forwarded or a problem at the receiving machine.

8

Press **Stop/Exit**.

## Paging

---

When Paging is chosen, the machine dials the cell phone or pager number you programmed. This activates your cell phone or pager so you will know that you have a fax message in the machine's memory.

- 1 Press **Menu**.
- 2 Press **▲** or **▼** to display **Fax**.  
Press **Fax**.
- 3 Press **▲** or **▼** to display  
**Setup Receive**.  
Press **Setup Receive**.
- 4 Press **▲** or **▼** to display  
**Forward/Page/Store**.  
Press **Forward/Page/Store**.
- 5 Press **Paging**.
- 6 Enter your cell phone or pager number followed by **##** (up to 20 digits) by pressing the buttons on the Touchscreen.  
Press **OK**.  
Do not include the area code if it is the same as that of your machine.  
For example, press  
18005551234##.
- 7 Do one of the following:
  - If your pager needs a PIN, enter the PIN, press **#**, press **Pause**, enter your fax number followed by **##**.  
Press **OK**. (For example, press:  
1 2 3 4 5 # Pause 1 8 0 0 5 5 6 7  
8 9 # #)
  - If you do not need a PIN, press **OK**.
  - If you are programming a cell phone number, press **OK**.

- 8 Press **Stop/Exit**.



### Note

---

- If you have set Paging, a backup copy will automatically be printed at the machine.
  - You cannot change a pager, cell phone or PIN number remotely.
-

## Fax Storage

The Fax Storage feature lets you store your received faxes in the machine's memory. You can retrieve stored fax messages from a fax machine at another location using the remote retrieval commands. (See *Retrieving fax messages* >> page 34.) Your machine will automatically print a copy of the stored fax.

- 1 Press Menu.
- 2 Press ▲ or ▼ to display Fax.  
Press Fax.
- 3 Press ▲ or ▼ to display Setup Receive.  
Press Setup Receive.
- 4 Press ▲ or ▼ to display Forward/Page/Store.  
Press Forward/Page/Store.
- 5 Press Fax Storage.
- 6 Press **Stop/Exit**.

## Changing Remote Fax Options

If received faxes are left in your machine's memory when you change to another Remote Fax Option, the LCD will ask you one of the following questions:

- Erase All Fax?
- Print All Fax?
  - If you press **Yes**, faxes in the memory will be erased or printed before the setting changes. If a backup copy has already been printed the faxes will not be printed again.
  - If you press **No**, faxes in the memory will not be erased or printed and the setting will be unchanged.

If received faxes are left in the machine's memory when you change to PC Fax Receive from another remote fax option (Fax Forward, Paging or Fax Storage), the LCD will ask you the following question:

- Send Fax to PC?
  - If you press **Yes**, faxes in the memory will be sent to your PC before the setting changes. Faxes in the memory will be sent to your PC when the PC-Fax Receive icon is active on your PC. (See Software User's Guide.)
  - If you press **No**, faxes in the memory will not be erased or transferred to your PC and the setting will be unchanged.
- Backup Print:On  
Backup Print:Off  
Press Backup Print:On or  
Backup Print:Off.

**! Important**

If you choose Backup Print On, the machine will also print received faxes at your machine so you will have a copy. This is a safety feature in case there is a power failure before the fax is forwarded or a problem at the receiving machine.

**Turning off Remote Fax Options**

- 1 Press **Menu**.
- 2 Press **▲** or **▼** to display **Fax**. Press **Fax**.
- 3 Press **▲** or **▼** to display **Setup Receive**. Press **Setup Receive**.
- 4 Press **▲** or **▼** to display **Forward/Page/Store**. Press **Forward/Page/Store**.
- 5 Press **Off**.

**Note**

The LCD will give you more options if there are received faxes still in your machine's memory. (See *Changing Remote Fax Options* >> page 32.)

- 6 Press **Stop/Exit**.

**Remote retrieval**

The remote retrieval feature lets you retrieve your stored fax messages when you are not at the machine. You can call your machine from any touch tone telephone or fax machine, then use the Remote Access Code to retrieve your messages.

**Setting a Remote Access Code**

The Remote Access Code feature lets you access the remote retrieval features when you are away from your machine. Before you use the remote access and retrieval features, you have to set up your own code. The default code is an inactive code: --\*.

- 1 Press **Menu**.
- 2 Press **▲** or **▼** to display **Fax**. Press **Fax**.
- 3 Press **▲** or **▼** to display **Remote Access**. Press **Remote Access**.
- 4 Enter a three-digit code using the numbers 0 – 9, \* or #. Press **OK**.
- 5 Press **Stop/Exit**.

**Note**

DO NOT use the same code used for your Fax Receive Code (\*51) or Telephone Answer Code (#51). (See Basic User's Guide: *Using Remote Codes*.)

You can change your code at any time. If you want to make your code inactive, press **Clear** and then **OK** in 4 to restore the inactive setting --\*.

## Using your Remote Access Code

- 1 Dial your fax number from a telephone or another fax machine using touch tone.
- 2 When your machine answers, immediately enter your Remote Access Code (3 digits followed by \*).
- 3 The machine signals if it has received messages:
  - *No beeps*  
No messages received.
  - *1 long beep*  
Fax message received.
- 4 The machine gives two short beeps to tell you to enter a command. (See *Remote fax commands* ►► page 36.) The machine will hang up if you wait longer than 30 seconds before entering a command. If you enter an invalid command the machine will beep three times.
- 5 Press **9 0** to reset the machine when you have finished.
- 6 Hang up.



### Note

If your machine is set to **Manual** mode, you can still access the remote retrieval features. Dial the fax number as usual and let the machine ring. After 100 seconds you will hear a long beep to tell you to enter the remote access code. You will then have 30 seconds to enter the code.

## Retrieving fax messages

- 1 Dial your fax number from a telephone or another fax machine using touch tone.
- 2 When your machine answers, immediately enter your Remote Access Code (3 digits followed by \*). If you hear one long beep, you have messages.
- 3 When you hear two short beeps, use the dial pad to press **9 6 2**.
- 4 Wait for a long beep, and then use the dial pad to enter the number of the remote fax machine where you want your fax messages sent, followed by **##** (up to 20 digits).
- 5 Hang up after you hear your machine beep. Your machine will call the remote machine, which will then print your fax messages.



### Note

You can insert a pause in a fax number by using the **#** key.



## Changing the Fax Forwarding number

You can change the default setting of your fax forwarding number from another telephone or fax machine using touch tone.

- 1 Dial your fax number from a telephone or another fax machine using touch tone.
- 2 When your machine answers, immediately enter your Remote Access Code (3 digits followed by \*). If you hear one long beep, you have messages.
- 3 When you hear two short beeps, use the dial pad to press **9 5 4**.
- 4 Wait for a long beep, and then use the dial pad to enter the new number of the remote fax machine where you want your fax messages forwarded followed by **##** (up to 20 digits).
- 5 Press **9 0** to reset the machine when you have finished.
- 6 Hang up after you hear your machine beep.



### Note

You can insert a pause in a fax number by using the # key.

## Remote fax commands

Follow the commands below to access features when you are away from the machine. When you call the machine and enter your Remote Access Code (3 digits followed by \*), the system will give two short beeps and you must enter a remote command.

Remote commands		Operation details
95	<b>Change the fax forwarding, paging or fax storage settings</b>	
	1 OFF	You can choose OFF after you have retrieved or erased all your messages.
	2 Fax Forwarding	One long beep means the change is accepted. If you hear three short beeps, you cannot make the change because something has not been set up (for example, a fax forwarding or paging number has not been registered). You can register your fax forwarding number by entering 4. (See <i>Changing the Fax Forwarding number</i> >> page 35.) Once you have registered the number, fax forwarding will work.
	3 Paging	
	4 Fax Forwarding number	
6 Fax Storage		
96	<b>Retrieve a fax</b>	
	2 Retrieve all faxes	Enter the number of a remote fax machine to receive stored fax messages. (See <i>Retrieving fax messages</i> >> page 34.)
	3 Erase faxes from the memory	If you hear one long beep, fax messages have been erased from the memory.
97	<b>Check the receiving status</b>	
	1 Fax	You can check whether your machine has received any faxes. If yes, you will hear one long beep. If no, you will hear three short beeps.
98	<b>Change the Receive Mode</b>	
	1 External TAD	If you hear one long beep, your change has been accepted.
	2 Fax/Tel	
	3 Fax Only	
90	<b>Exit</b>	Press <b>9 0</b> to exit remote retrieval. Wait for the long beep, then replace the handset.

## Additional receiving operations

### Printing a reduced incoming fax

If you choose **On**, the machine automatically reduces each page of an incoming fax to fit on one page of Letter, A4, Legal or Folio size paper.

The machine calculates the reduction ratio by using the page size of the fax and your Paper Size and Tray Use settings. (See Basic User's Guide: *Paper Size and Type* and *Tray Use in Fax Mode*.)

- 1 Press **Menu**.
- 2 Press **▲** or **▼** to display **Fax**.  
Press **Fax**.
- 3 Press **▲** or **▼** to display **Setup Receive**.  
Press **Setup Receive**.
- 4 Press **▲** or **▼** to display **Auto Reduction**.  
Press **Auto Reduction**.
- 5 Press **On** (or **Off**).
- 6 Press **Stop/Exit**.

### Duplex (2-sided) printing for Fax mode

Your machine can automatically print received faxes onto both sides of the paper when Duplex is set to **On**.

You can use Letter, Legal or Folio (8.5 in. × 13 in.) size paper for this function [16 to 28 lb (60 to 105 g/m<sup>2</sup>)].

- 1 Press **Menu**.
- 2 Press **▲** or **▼** to display **Fax**.  
Press **Fax**.
- 3 Press **▲** or **▼** to display **Setup Receive**.  
Press **Setup Receive**.
- 4 Press **▲** or **▼** to display **Duplex**.  
Press **Duplex**.
- 5 Press **On** (or **Off**).
- 6 Press **Stop/Exit**.



#### Note

- When Duplex is turned on incoming faxes will automatically be reduced to fit the size of paper in the paper tray.
- When Duplex is set to **On**, the LCD displays  (Duplex icon).

## Setting the Fax Receive Stamp

---

You can set the machine to print the received date and time in the top center of each received fax page.

- 1 Press **Menu**.
- 2 Press **▲** or **▼** to display **Fax**. Press **Fax**.
- 3 Press **▲** or **▼** to display **Setup Receive**. Press **Setup Receive**.
- 4 Press **▲** or **▼** to display **Fax Rx Stamp**. Press **Fax Rx Stamp**.
- 5 Press **On** (or **Off**).
- 6 Press **Stop/Exit**.



### Note

---

- The received time and date will not appear when using Internet Fax.
  - Make sure you have set the current date and time in the machine. (See Quick Setup Guide.)
- 

## Receiving a fax at the end of a conversation

---

At the end of a conversation you can ask the other party to send you a fax before you both hang up.

- 1 Ask the other party to place the document in their machine and to press the **Start** or **Send** key.
- 2 When you hear the CNG tones (slowly repeating beeps), press **Start**.
- 3 Press **Receive** to receive a fax.
- 4 Replace the external handset.

## Setting the Print Density

You can adjust the Print Density setting to make your printed pages darker or lighter.

- 1 Press **Menu**.
- 2 Press **▲** or **▼** to display **Fax**.  
Press **Fax**.
- 3 Press **▲** or **▼** to display  
**Setup Receive**.  
Press **Setup Receive**.
- 4 Press **▲** or **▼** to display  
**Print Density**.  
Press **Print Density**.
- 5 Press **▶** to make the print darker.  
Or, press **◀** to make the print lighter.  
Press **OK**.
- 6 Press **Stop/Exit**.

## Printing a fax from the memory

If you are using the Fax Storage feature (Menu, Fax, Setup Receive, Forward/Page/Store), you can still print a fax from the memory when you are at your machine. (See *Fax Storage* >> page 32.)

- 1 Press **Menu**.
- 2 Press **▲** or **▼** to display **Fax**.  
Press **Fax**.
- 3 Press **▲** or **▼** to display **Print Fax**.  
Press **Print Fax**.
- 4 Press **Start**.
- 5 Press **Stop/Exit**.

## Receiving faxes into memory when the paper tray is empty

As soon as the paper tray becomes empty during fax reception, the LCD shows **No Paper** and begins receiving faxes into the machine's memory. Put some paper in the paper tray. (See *Basic User's Guide: Loading paper and print media*.)

The machine will carry on receiving the fax, with the remaining pages being stored in the memory, if enough memory is available.

Incoming faxes will continue to be stored in the memory until the memory becomes full or paper is loaded in the paper tray. When the memory is full the machine will stop automatically answering calls. To print the faxes, put fresh paper in the tray.

## Polling overview

Polling lets you set up your machine so other people can receive faxes from you, but they pay for the call. It also lets you call somebody else's fax machine and receive a fax from it, so you pay for the call. The polling feature needs to be set up on both machines for this to work. Not all fax machines support polling.

### Polling receive

Polling receive lets you call another fax machine to receive a fax.

- 1 Press **Fax**.
- 2 Press ◀ or ▶ to display **Polling RX**. Press **Polling RX**.
- 3 Press **On**.
- 4 Enter the fax number you are polling using **One Touch**, **Speed Dial**, or the dial pad. Press **Start**.

### Sequential polling

Sequential polling lets you request documents from several fax machines in one operation. Afterwards, a Sequential Polling Report will be printed.

- 1 Press **Fax**.
- 2 Press ◀ or ▶ to display **Polling RX**. Press **Polling RX**.
- 3 Press **On**.
- 4 Press ◀ or ▶ to display **Broadcasting**. Press **Broadcasting**.

- 5 Do one of the following:
  - Press **Manual** and enter a number by pressing the buttons on the Touchscreen.  
Press **OK**.
  - Press **Address Book**. Press **#001 A** to choose **Alphabetical Order** or **Numerical Order**. Press ▲ or ▼ to select a number.  
Press **OK**.



#### Note

One Touch Dial numbers begin with \*.  
Speed Dial numbers begin with #.

- 6 After you have entered all the fax numbers by repeating step 5, press **OK**.
- 7 Press **Start**.  
The machine polls each number or Group number in turn for a document.

### Stop Polling

To cancel the polling process, press **Stop/Exit** while the machine is dialing.

To cancel all sequential polling receive jobs, see *Canceling a Sequential Polling Job* >> page 41.

## Canceling a Sequential Polling Job

- 1 Press **Stop/Exit**.
- 2 Do one of the following:
  - To cancel the entire sequential polling job, press `Entire Seq. Poll.` Go to step 3.
  - To cancel the current job, press the button that displays the number being dialed. Go to step 4.
  - To exit without canceling, press **Stop/Exit**.
- 3 When the LCD asks if you want to cancel the entire sequential polling job, do one of the following:
  - Press `Yes` to confirm.
  - To exit without canceling, press `No` or **Stop/Exit**.
- 4 Do one of the following:
  - To cancel the current job, press `Yes`.
  - To exit without canceling, press `No` or **Stop/Exit**.

## Telephone line services

### Tone or Pulse (Canada only)

If you have a Pulse dialing service, but need to send Tone signals (for example, for telephone banking), follow the instructions below. If you have Touch Tone service, you will not need this feature to send tone signals.

- 1 Press **Hook**.
- 2 Press **#** on the machine's control panel. Any digits dialed after this will send tone signals.  
When you are finished with the call, the machine will return to the Pulse dialing service.

### For Fax/Tel mode only

When the machine is in Fax/Tel mode, it will use the F/T Ring Time (pseudo/double-ringing) to alert you to pick up a voice call.

If you are at the machine, lift the external telephone's handset, and then press **Hook** to answer.

If you are at an extension telephone, lift the handset during the F/T Ring Time and then press **#51** between the pseudo/double rings. If no one is on the line, or if someone wants to send you a fax, send the call back to the machine by pressing **\*51**.

## Special line considerations

### Roll over telephone lines

A roll over telephone system is a group of two or more separate telephone lines that pass incoming calls to each other if they are busy. The calls are usually passed down or "rolled over" to the next available telephone line in a preset order.

Your machine can work in a roll over system as long as it is the last number in the sequence, so the call cannot roll away. Do not put the machine on any of the other numbers; when the other lines are busy and a second fax call is received, the fax call would be transferred to a line that does not have a fax machine. **Your machine will work best on a dedicated line.**

### Two-line telephone system

A two-line telephone system is nothing more than two separate telephone numbers on the same wall outlet. The two telephone numbers can be on separate jacks (RJ11) or combined into one jack (RJ14). Your machine must be plugged into an RJ11 jack. RJ11 and RJ14 jacks may be equal in size and appearance and both may contain four wires (black, red, green, yellow). To test the type of jack, plug in a two-line telephone and see if it can access both lines. If it can, you must separate the line for your machine.



## Converting telephone wall outlets

There are three ways to convert to an RJ11 jack. The first two ways may require assistance from the telephone company. You can change the wall outlets from one RJ14 jack to two RJ11 jacks. Or, you can have an RJ11 wall outlet installed and slave or jump one of the telephone numbers to it.

The third way is the easiest: Buy a triplex adapter. You can plug a triplex adapter into an RJ14 outlet. It separates the wires into two separate RJ11 jacks (Line 1, Line 2) and a third RJ14 jack (Lines 1 and 2). If your machine is on Line 1, plug the machine into L1 of the triplex adapter. If your machine is on Line 2, plug it into L2 of the triplex adapter.

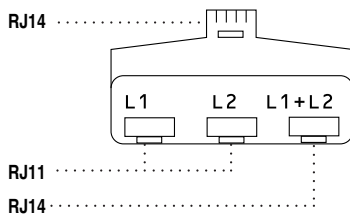

## Installing machine, external two-line TAD and two-line telephone

When you are installing an external two-line telephone answering device (TAD) and a two-line telephone, your machine must be isolated on one line at both the wall jack and at the TAD. The most common connection is to put the machine on Line 2, which is explained in the following steps. The back of the two-line TAD must have two telephone jacks: one labeled L1 or L1/L2, and the other labeled L2. You will need at least three telephone line cords, the one that came with your machine and two for your external two-line TAD. You will need a fourth line cord if you add a two-line telephone.

- 1 Put the two-line TAD and the two-line telephone next to your machine.
- 2 Plug one end of the telephone line cord for your machine into the L2 jack of the triplex adapter. Plug the other end into the LINE jack on the back of the machine.
- 3 Plug one end of the first telephone line cord for your TAD into the L1 jack of the triplex adapter. Plug the other end into the L1 or L1/L2 jack of the two-line TAD.
- 4 Plug one end of the second telephone line cord for your TAD into the L2 jack of the two-line TAD. Plug the other end into the EXT. jack on the left side of the machine.

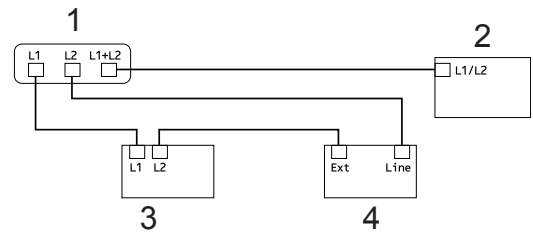

- 1 Triplex Adapter
- 2 Two Line Telephone
- 3 External Two Line TAD
- 4 Machine

You can keep two-line telephones on other wall outlets as always. There are two ways to add a two-line telephone to the machine's wall outlet. You can plug the telephone line cord from the two-line telephone into the L1+L2 jack of the triplex adapter. Or, you can plug the two-line telephone into the TEL jack of the two-line TAD.

## Additional dialing operations

### Dialing access codes and credit card numbers

---

Sometimes you may want to choose from several long distance carriers when you send a fax. Rates may vary depending on the time and destination. To take advantage of low rates, you can store the access codes of long distance carriers and credit card numbers as One Touch and Speed Dial numbers. You can store these long dialing sequences by dividing them and setting them up as separate One Touch and Speed Dial numbers in any combination. You can even include manual dialing using the dial pad. (See Basic User's Guide: *Storing numbers*.)

For example, you might have stored '555' on Speed Dial #003 and '7000' on Speed Dial #002. You can use them both to dial '555-7000' if you press the following keys:

Press  (Address Book), #003 and Send a fax.

Press Address Book, #002, Send a fax and **Start**.

Numbers can be added manually by entering them on the dial pad:

Press  (Address Book), #003, Send a fax, **7001** (on the dial pad), and **Start**.

This would dial '555-7001'. You can also add a pause by pressing the **Redial/Pause** key.

## Additional ways to store numbers

### Setting up Groups for Broadcasting

If you often want to send the same fax message to many fax numbers you can set up a Group.

Groups are stored on a One Touch button or a Speed Dial number. Each Group uses up a One Touch button or a Speed Dial location. You can then send the fax message to all the numbers stored in a Group just by pressing a One Touch button or entering a Speed Dial number, pressing *Send a fax* or *Send a E-mail*, and then pressing **Start**.

Before you can add numbers to a Group, you need to store them as One Touch or Speed Dial numbers. You can set up to 20 small Groups, or you can assign up to 331 numbers to one large Group.

For a listing of the options available when you set up Group numbers, see the table on page 47.

- 1 Press  (Address Book).
- 2 Press *Edit*.
- 3 Press *Setup Groups (One Touch)* or *Setup Groups (Speed Dial)* to choose where you want to store the new Group.



#### Note

The machine automatically allocates an available Speed Dial number or One Touch Dial location for the new Group.

- 4 Do one of the following:
  - Press **OK** to accept the displayed One Touch or Speed Dial number.
  - Enter a new number using the buttons on the Touchscreen.  
Press **OK**.
- 5 Enter the Group name (up to 15 characters) by pressing the buttons on the Touchscreen.  
Press  to choose numbers, letters or special characters. (See Basic User's Guide: *Entering text*.)  
Press **OK**.
- 6 Do one of the following:
  - Press **OK** to accept the displayed Group number.
  - Enter a new Group number using the buttons on the Touchscreen.  
Press **OK**.
- 7 To select the Registration Type (Dial type) and the file type, press **◀** or **▶** to display  
Fax/IFAX,  
E-Mail B&W PDF,  
E-Mail B&W TIFF,  
E-Mail Color PDF,  
E-Mail Color JPEG,  
E-Mail Color XPS,  
E-Mail Gray PDF,  
E-Mail Gray JPEG,  
E-Mail Gray XPS.  
  
Press the option you want.

- 8 Add One Touch or Speed Dial numbers to the Group by pressing the check box to display a red check mark. If you want to list the numbers in alphabetical order, press **#001 A**. Press OK.



**Note**

- One Touch Dial numbers begin with \*.  
Speed Dial numbers begin with #.
- If the stored Registration Type (Dial type) of a One Touch Dial number or a Speed Dial number is not compatible with the Registration Type (Dial type) selected in step 7, the One Touch Dial number or Speed Dial number will be dimmed on the LCD.

- 9 To choose the fax/scan resolution for the Group number, go to the appropriate next step as shown in the following table.

Option selected in step 7	Go to step
Fax/IFAX	10
E-Mail B&W PDF	11
E-Mail B&W TIFF	
E-Mail Color PDF	12
E-Mail Color JPEG	
E-Mail Color XPS	
E-Mail Gray PDF	13
E-Mail Gray JPEG	
E-Mail Gray XPS	

- 10 Select the resolution from Standard, Fine, S.Fine<sup>1</sup> or Photo and go to step 15.

<sup>1</sup> S.Fine is available if the Group includes only fax numbers.

- 11 Select the resolution from 300 dpi, 200 dpi or 200 x 100 dpi.
  - If you chose E-Mail B&W PDF, go to step 14.
  - If you chose E-Mail B&W TIFF, go to step 15.

- 12 Select the resolution from 100 dpi, 200 dpi, 300 dpi, 600 dpi or Auto.
  - If you chose E-Mail Color PDF, go to step 14.
  - If you chose E-Mail Color JPEG or E-Mail Color XPS, go to step 15.

- 13 Select the resolution from 100 dpi, 200 dpi, 300 dpi or Auto.
  - If you chose E-Mail Gray PDF, go to step 14.
  - If you chose E-Mail Gray JPEG or E-Mail Gray XPS, go to step 15.

- 14 Select the PDF type from PDF, PDF/A, Secure PDF or Signed PDF that will be used to send E-mail.



**Note**

If you choose Secure PDF, the machine will ask you to enter a four-digit password using the numbers 0-9 before it starts scanning.

- 15 Press OK to confirm.
- 16 Press **Stop/Exit**.

## Options for Setting Up Groups

The following chart shows the selections for setting up Group numbers. When you store numbers, the LCD instructs you to choose from the options shown in the following steps.

Step 1 Enter Group Location	Step 2 Enter Group Name Press OK	Step 3 Enter Group Number (1 to 20)	Step 4 Select Registration Type (Dial Type)	Step 5 Add Stored One Touch and Speed Dial Numbers to the Group	Step 6 Select Resolution	Step 7 Select File Type
One Touch or Speed Dial			Fax/IFAX	Fax Number or E-mail Address	Standard, Fine, S.Fine <sup>1</sup> , Photo	-
			E-Mail B&W PDF	E-mail Address	300 dpi, 200 dpi, 200 x 100 dpi	PDF, PDF/A, Secure PDF, Signed PDF
			E-Mail B&W TIFF		300 dpi, 200 dpi, 200 x 100 dpi	-
			E-Mail Color PDF		100 dpi, 200 dpi, 300 dpi, 600 dpi, Auto	PDF, PDF/A, Secure PDF, Signed PDF
			E-Mail Color JPEG		100 dpi, 200 dpi, 300 dpi, 600 dpi, Auto	-
			E-Mail Color XPS		100 dpi, 200 dpi, 300 dpi, 600 dpi, Auto	-
			E-Mail Gray PDF		100 dpi, 200 dpi, 300 dpi, Auto	PDF, PDF/A, Secure PDF, Signed PDF
			E-Mail Gray JPEG		100 dpi, 200 dpi, 300 dpi, Auto	-
			E-Mail Gray XPS		100 dpi, 200 dpi, 300 dpi, Auto	-

<sup>1</sup> S.Fine does not appear if you add an E-mail address in step 5.



### Note

- PDF/A is a PDF file format intended for long-term archiving. This format contains all the necessary information to be able to reproduce the document after long-term storage.
- Secure PDF is a PDF file format that has been password-protected.
- Signed PDF is a PDF file format that helps prevent data tampering and the impersonation of an author by including a digital certificate within the document. If you choose Signed PDF, you must install a certificate on your machine using Web Based Management. Choose **Signed PDF** from **Administrator** in Web Based Management. (See How to install a certificate ►► Network User's Guide.)

## Changing Group numbers

You can change a Group number that has already been stored. If the Group has a fax forwarding number, it will be dimmed on the LCD. You cannot select the number to make changes.

### Changing a Group name, Resolution or PDF type

- 1 Press  (Address Book).
- 2 Press **Edit**.
- 3 Press **Change**.
- 4 Press **▲** or **▼** to display the Group you want to change. Press the Group.
- 5 You can change the Group settings:
  - If you chose Name, enter the name (up to 15 characters) by pressing the buttons on the Touchscreen. Press **OK**.
  - If you chose Resolution, press one of the available resolution options displayed on the LCD.
  - If you chose PDF type, press one of the available file type options displayed on the LCD.

The LCD will display your new setting.



### Note

How to change the stored name:

If you want to change a character, press **◀** or **▶** to position the cursor under the character you want to change, and then press . Re-enter the character.

- 6 When you are finished making changes to the Group, press **OK**.
- 7 Press **Stop/Exit**.

### Adding and deleting numbers in a Group

If a number in the Group has a fax forwarding number, it will be dimmed on the LCD and cannot be deleted from the Group.

- 1 Press  (Address Book).
- 2 Press **Edit**.
- 3 Press **Change**.
- 4 Press **▲** or **▼** to display the Group you want to change. Press the Group.
- 5 Press **Add/Delete**.
- 6 Press **▲** or **▼** to display the number you want to add or delete.
- 7 Press the check box of each number you want to add to check it. Press the check box of each number you want to delete to uncheck it. Press **OK** to confirm.
- 8 Press **OK**.
- 9 Press **Stop/Exit**.

## Deleting Group numbers

You can delete a Group number that has already been stored. If a Group has a scheduled job or fax forwarding number, it will be dimmed on the LCD. You cannot select the number to delete it.

- 1 Press  (Address Book).
- 2 Press **Edit**.
- 3 Press **Delete**.
- 4 Press **▲** or **▼** to display the Group you want to delete.  
Press the check box of the Group you want to delete to check it.  
Press **OK**.
- 5 When the LCD shows **Erase This Data?**, do one of the following:
  - To Delete the Group, press **Yes**.
  - To exit without deleting the Group, press **No**.
- 6 Press **Stop/Exit**.

# 6

## Printing reports

### Fax reports

Some fax reports (Transmission Verification Report and Fax Journal) can be printed automatically and manually.

### Transmission Verification Report

You can use the Transmission Verification Report as proof that you sent a fax. (See Basic User's Guide: *Transmission Verification Report*.)

### Fax Journal (Activity Report)

You can set the machine to print a journal at specific intervals (every 50 faxes, 6, 12 or 24 hours, 2 or 7 days). If you set the interval to *Off*, you can still print the report by following the steps in *How to print a report* >> page 51. The factory setting is *Every 50 Faxes*.

- 1 Press **Menu**.
- 2 Press **▲** or **▼** to display **Fax**. Press **Fax**.
- 3 Press **▲** or **▼** to display **Report Setting**. Press **Report Setting**.
- 4 Press **Journal Period**.

- 5 Press **◀** or **▶** to choose an interval. If you choose *Every 50 Faxes*, go to step 8.

- 6, 12, 24 hours, 2 or 7 days

The machine will print the report at the chosen time and then erase all jobs from its memory.

If the machine's memory becomes full with 200 jobs before the time you chose has passed, the machine will print the Journal early and then erase all jobs from the memory. If you want an extra report before it is due to print, you can print it without erasing the jobs from the memory.

- **Every 50 Faxes**

The machine will print the Journal when the machine has stored 50 jobs.

- 6 To enter the time to start printing, do one of the following:

- If you have set **12h Clock** in the **Date&Time** setting, enter the time (in 12-hour format) by pressing the buttons on the Touchscreen, and then press **AM** or **PM**.

Press **OK**.

- If you have set **24h Clock** in the **Date&Time** setting, enter the time (in 24-hour format) by pressing the buttons on the Touchscreen.

Press **OK**.

(For example: enter 19:45 for 7:45 PM.)

- 7 If you chose *Every 7 Days* in step 5, press **◀** or **▶** to choose the day of the week to print the journal.

- 8 Press **Stop/Exit**.



# Reports

The following reports are available:

- 1 **Transmission**  
Displays the Transmission Verification Report for your last outgoing 200 faxes and prints the last report.
- 2 **Tel Index List**  
Prints a list of names and numbers stored in the One Touch and Speed Dial memory in numerical or alphabetical order.
- 3 **Fax Journal**  
Prints a list of information about your last 200 incoming and outgoing faxes. (TX: transmit.) (RX: receive.)
- 4 **User Settings**  
Prints a list of your current settings.
- 5 **Network Config**  
Lists your network settings.
- 6 **Drum Dot Print**  
Prints the drum dot check sheet to troubleshoot a dotted print problem.
- 7 **WLAN Report**  
Prints the result of wireless LAN connectivity diagnosis.

## How to print a report

- 1 Press **Menu**.
- 2 Press **▲** or **▼** to display **Print Reports**. Press **Print Reports**.
- 3 Press **▲** or **▼** to display the report you want to print. Press the report you want to print.
- 4 Do one of the following:
  - If you chose **Transmission**, go to step 5.
  - If you chose **Tel Index List**, press **Numerical Order** or **Alphabetical Order**. Go to step 6.
  - If you chose other than **Transmission** or **Tel Index List**, go to step 6.
- 5 Do one of the following:
  - To view the **Transmission Verification Report**, press **View on LCD**.
  - To print the **Transmission Verification Report**, press **Print Report**.
- 6 Press **Start**.
- 7 Press **Stop/Exit**.

## Copy settings

You can change the copy settings temporarily for the next copy.

Press **Copy** on the Touchscreen and then press ◀ or ▶ to scroll through the copy settings. When the setting you want is displayed, press the button.

When you are finished changing settings, press **Start**.

## Stop copying

To stop copying, press **Stop/Exit**.

## Improving copy quality

You can choose from a range of quality settings. The default setting is **Auto**.

- **Auto**  
Auto is the recommended mode for ordinary printouts. Suitable for documents that contain both text and photographs.
- **Text**  
Suitable for documents containing only text.
- **Photo**  
Suitable for copying photographs.
- **Graph**  
Suitable for copying receipts.

- 1 Press **Copy**.
- 2 Load your document.
- 3 Enter the number of copies you want.
- 4 Press ◀ or ▶ to display **Quality**. Press **Quality**.
- 5 Press **Auto**, **Text**, **Photo** or **Graph**.
- 6 If you do not want to change additional settings, press **Start**.

## Enlarging or reducing the image copied

To enlarge or reduce the next copy follow the instructions below:

- 1 Press **Copy**.
- 2 Load your document.
- 3 Enter the number of copies you want.
- 4 Press **◀** or **▶** to display **Enlarge/ Reduce**. Press **Enlarge/ Reduce**.
- 5 Press **100%**, **Enlarge**, **Reduce**, **Auto** or **Custom (25-400%)**.
- 6 Do one of the following:
  - If you chose **Enlarge** or **Reduce**, press the enlargement or reduction ratio button you want.
  - If you chose **Custom (25-400%)**, enter an enlargement or reduction ratio from 25% to 400%. Press **OK**.
  - If you chose **100%** or **Auto**<sup>1</sup>, go to step 7.

<b>100%*</b>
104% EXE ⇒ LTR
141% A5 ⇒ A4
200%
50%
70% A4 ⇒ A5
78% LGL ⇒ LTR
83% LGL ⇒ A4
85% LTR ⇒ EXE
91% Full Page
94% A4 ⇒ LTR
97% LTR ⇒ A4
Auto <sup>1</sup>
Custom (25-400%)

\* The factory setting is shown in **Bold** with an asterisk.

<sup>1</sup> Auto sets the machine to calculate the reduction ratio that best fits the size of paper. Auto is only available when using the ADF.

- 7 If you do not want to change additional settings, press **Start**.



### Note

Page Layout Options **2in1 (P)**, **2in1 (L)**, **2in1 (ID)**, **4in1 (P)** and **4in1 (L)** are *not* available with **Enlarge/Reduce**.

## Duplex (2-sided) Copying

If you want to use the automatic duplex copy feature, load your document in the ADF.

If you get an Out of Memory message while you are making duplex copies, try installing extra memory. (See *Installing extra memory* >> page 80.)

You must choose a 2-sided copy layout from the following options before you can start duplex copying. The layout of your document determines which 2-sided copy layout you should choose.

Portrait

### ■ 2side→2side

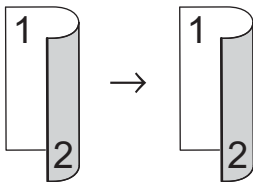

### ■ 1side→2side Long Edge Flip

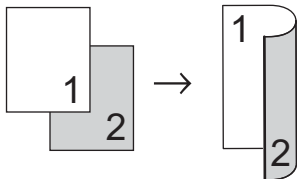

### ■ 2side→1side Long Edge Flip

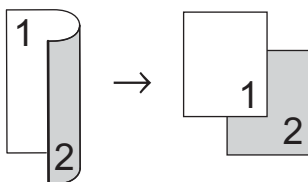

### ■ 1side→2side Short Edge Flip

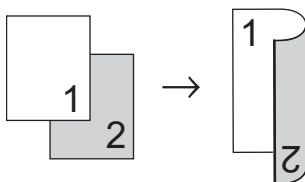

### ■ 2side→1side Short Edge Flip

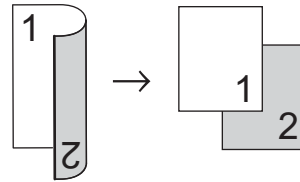

Landscape

### ■ 2side→2side

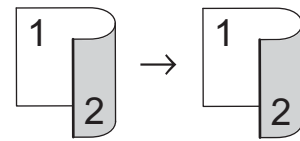

### ■ 1side→2side Long Edge Flip

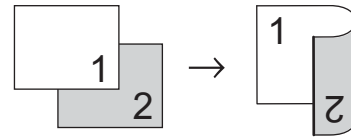

### ■ 2side→1side Long Edge Flip

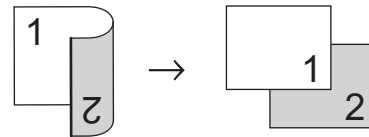

### ■ 1side→2side Short Edge Flip

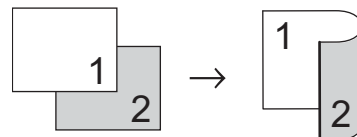

### ■ 2side→1side Short Edge Flip

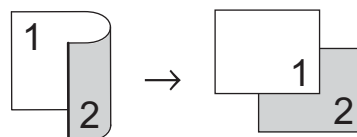

- 1 Press **Copy**.
- 2 Load your document.
- 3 Enter the number of copies you want.
- 4 Press **◀** or **▶** to display **Duplex Copy**. Press **Duplex Copy**.
- 5 Press **◀** or **▶** to display the following layout options:  
 2side⇒2side,  
 1side⇒2side LongEdgeFlip,  
 2side⇒1side LongEdgeFlip,  
 1side⇒2side ShortEdgeFlip,  
 2side⇒1side ShortEdgeFlip,  
 Off

Press the option you want.

- 6 If you do not want to change additional settings, press **Start**.

## Tray selection

---

You can change the Tray Use option for the next copy.

- 1 Press **Copy**.
- 2 Load your document.
- 3 Enter the number of copies you want.
- 4 Press **◀** or **▶** to display **Tray Use**. Press **Tray Use**.
- 5 Press **MP>T1**, **MP>T1>T2**<sup>1</sup>, **T1>MP**, **T1>T2>MP**<sup>1</sup>, **Tray#1 Only**, **Tray#2 Only**<sup>1</sup> or **MP Only**.  
<sup>1</sup> **T2 and Tray#2 Only** appears only if Tray 2 is installed.
- 6 If you do not want to change additional settings, press **Start**.



### Note

---

To change the default setting for Tray Use  
 >> Basic User's Guide: *Tray Use in Copy mode*

---

## Adjusting Brightness and Contrast

### Brightness

Adjust the copy brightness to make copies darker or lighter.

- 1 Press **Copy**.
- 2 Load your document.
- 3 Enter the number of copies you want.
- 4 Press ◀ or ▶ to display **Brightness**. Press **Brightness**.
- 5 Press ◀ to make a darker copy or press ▶ to make a lighter copy. Press **OK**.
- 6 If you do not want to change additional settings, press **Start**.

### Contrast

Adjust the contrast to help an image look sharper and more vivid.

- 1 Press **Copy**.
- 2 Load your document.
- 3 Enter the number of copies you want.
- 4 Press ◀ or ▶ to display **Contrast**. Press **Contrast**.
- 5 Press ◀ to decrease the contrast or press ▶ to increase the contrast. Press **OK**.
- 6 If you do not want to change additional settings, press **Start**.

## Sorting copies

You can sort multiple copies. Pages will be stacked in the order 1 2 3, 1 2 3, 1 2 3, and so on.

- 1 Press **Copy**.
- 2 Load your document.
- 3 Enter the number of copies you want.
- 4 Press ◀ or ▶ to display **Stack/Sort**. Press **Stack/Sort**.
- 5 Press **Sort**.
- 6 If you do not want to change additional settings, press **Start** to scan the page. If you placed the document in the ADF, the machine scans the pages and starts printing.

**If you are using the scanner glass, go to step 7.**

- 7 After the machine scans the page, press **Yes** to scan the next page.
- 8 Place the next page on the scanner glass. Press **Start**. Repeat steps 7 and 8 for each page of the layout.
- 9 After all the pages have been scanned, press **No** in step 7 to finish.

## Making N in 1 copies (page layout)

You can reduce the amount of paper used when copying by using the N in 1 copy feature. This allows you to copy two or four pages onto one page. If you want to copy both sides of an ID card onto one page, see *2 in 1 ID Copy* >> page 59.

### ! Important

- Please make sure the paper size is set to Letter, A4, Legal or Folio.
- You cannot use the Enlarge/Reduce setting with the N in 1 feature.
- (P) means Portrait and (L) means Landscape.

- 1 Press **Copy**.
- 2 Load your document.
- 3 Enter the number of copies you want.
- 4 Press ◀ or ▶ to display **Page Layout**. Press **Page Layout**.
- 5 Press ◀ or ▶ to display **Off (1in1)**, **2in1 (P)**, **2in1 (L)**, **2in1 (ID)**<sup>1</sup>, **4in1 (P)** or **4in1 (L)**. Press the button you want.

<sup>1</sup> For details about **2in1 (ID)**, see *2 in 1 ID Copy* >> page 59.

- 6 If you do not want to change additional settings, press **Start** to scan the page. If you placed the document in the ADF, the machine scans the pages and starts printing.

**If you are using the scanner glass, go to step 7.**

- 7 After the machine scans the page, press **Yes** to scan the next page.
- 8 Place the next page on the scanner glass. Press **Start**. Repeat steps 7 and 8 for each page of the layout.
- 9 After all the pages have been scanned, press **No** in step 7 to finish.

### If you are copying from the ADF:

Insert your document *face up* in the direction shown below:

#### ■ 2in1(P)



#### ■ 2in1(L)

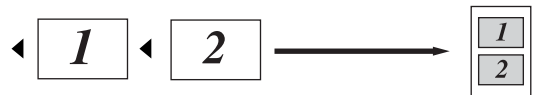

#### ■ 4in1(P)



#### ■ 4in1(L)

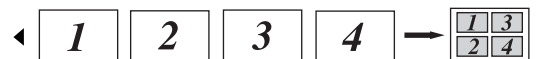

**If you are copying from the scanner glass:**

Insert your document *face down* in the direction shown below:

■ **2in1(P)**



■ **2in1(L)**

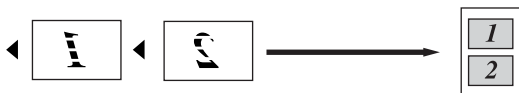

■ **4in1(P)**



■ **4in1(L)**





## 2 in 1 ID Copy

You can copy both sides of your identification card onto one page, keeping the original card size.



### Note

You can copy an identification card to the extent permitted under applicable laws.

See Product Safety Guide: *Legal limitations for copying (MFC and DCP only)*.

- 1 Press **Copy**.
- 2 Place your identification card *face down* at the left corner of the scanner glass.

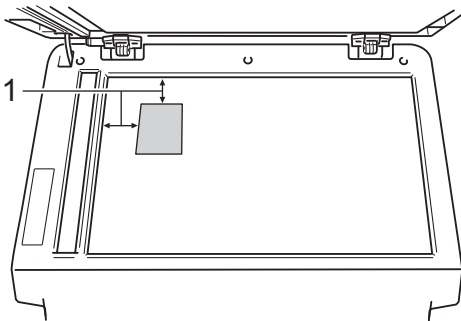

### 1 0.16 in. (4 mm) or greater (top, left)

- Even if a document is placed on the ADF, the machine scans the data from the scanner glass when in this mode.

- 3 Enter the number of copies you want.
- 4 Press ◀ or ▶ to display **Page Layout**. Press **Page Layout**.
- 5 Press ◀ or ▶ to display **2in1 (ID)**. Press **2in1 (ID)**.
- 6 Press **Start**.  
After the machine scans the first side of the card, the LCD will display  
**Turn over the ID Card Then  
Press Start**.

- 7 Turn over your identification card and place it on the left side of the scanner glass.
- 8 Press **Start**. The machine scans the other side of the card and prints the page.



### Note

When 2 in 1 ID Copy is chosen, the machine sets the quality to **Photo** and the contrast to **+2**.

## Setting your changes as the new default

You can save the copy settings for *Quality*, *Brightness* and *Contrast* you use most often by setting them as the default. These settings will stay until you change them again.

- 1 Press **Copy**.
- 2 Press **◀** or **▶** to choose the setting you want to change, and then press the new option.  
Repeat this step for each setting you want to change.
- 3 After changing the last setting, press **◀** or **▶** to display *Set New Default*. Press **Set New Default**.
- 4 Press **Yes**.
- 5 Press **Stop/Exit**.

## Restoring all copy settings to the factory settings

You can restore all the copy settings you have changed to the factory settings. These settings will stay until you change them again.

- 1 Press **Copy**.
- 2 Press **◀** or **▶** to display *Factory Reset*. Press **Factory Reset**.
- 3 Press **Yes**.
- 4 Press **Stop/Exit**.

## Setting your favorites

You can store the copy settings that you use most often by setting them as a favorite. You can set up to three favorites.

- 1 Press **Copy**.
- 2 Choose the copy option and settings you want to store.
- 3 Press **◀** or **▶** to display *Favorite Settings*. Press **Favorite Settings**.
- 4 Press **Store**.
- 5 Press the location where you want to store your setting for *Favorite:1*, *Favorite:2* or *Favorite:3*.
- 6 Do one of the following:
  - If you want to rename your setting, press **✕** to delete characters. Then enter the new name (up to 12 characters). Press **OK**.
  - If you do not want to rename your setting, press **OK**.
- 7 Press **Stop/Exit**.

## Retrieving your favorite setting

When you are ready to use one of your favorite set of settings, you can recall it.

- 1 Press **Copy**.
- 2 Press  **Favorite**.
- 3 Press the favorite setting you want to retrieve.
- 4 Press **Start**.

## Rename your favorite setting

After you stored your favorite setting, you can rename it.

- 1 Press **Copy**.
- 2 Press **◀** or **▶** to display **Favorite Settings**.  
Press **Favorite Settings**.
- 3 Press **Rename**.
- 4 Press the favorite setting you want to rename.
- 5 Enter the new name (up to 12 characters).
- 6 Press **OK**.
- 7 Press **Stop/Exit**.

# A

## Routine maintenance

### Cleaning and checking the machine

Clean the outside and inside of the machine regularly with a dry, lint-free cloth. When you replace the toner cartridge or the drum unit, make sure that you clean the inside of the machine. If printed pages are stained with toner, clean the inside of the machine with a dry, lint-free cloth.

#### WARNING



- DO NOT put a toner cartridge or a toner cartridge and drum unit assembly into a fire. It could explode, resulting in injuries.
- DO NOT use flammable substances, any type of spray, or an organic solvent/liquid containing alcohol or ammonia to clean the inside or outside of the product. Doing so could cause a fire or electrical shock. Instead, use only a dry, lint-free cloth.

(See Product Safety Guide: *To use the product safely.*)



#### Important

Use neutral detergents. Cleaning with volatile liquids such as thinner or benzene will damage the surface of the machine.

## Cleaning the outside of the machine

- 1 Turn off the machine's power switch.
- 2 Unplug the telephone line cord first, disconnect all cables, and then unplug the power cord from the AC power outlet.
- 3 Wipe the outside of the machine with a dry, lint-free cloth to remove dust.



- 4 Pull the paper tray completely out of the machine.

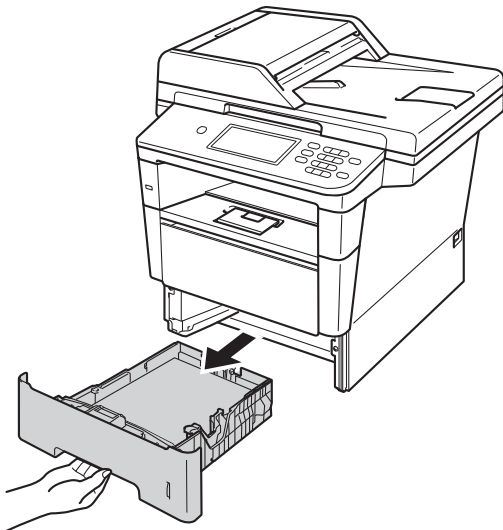

- 5 Remove anything that is stuck inside the paper tray.
- 6 If paper is loaded in the paper tray, remove it.
- 7 Wipe the inside and the outside of the paper tray with a dry, lint-free cloth to remove dust.

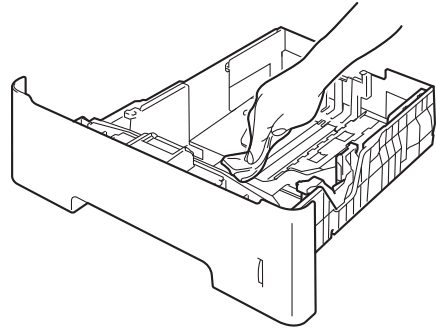

- 8 Re-load the paper and put the paper tray firmly back in the machine.
- 9 Plug the machine's power cord back into the AC power outlet first, connect all cables, and then plug in the telephone line cord.
- 10 Turn on the machine's power switch.

A

## Cleaning the scanner

- 1 Turn off the machine's power switch.
- 2 Unplug the telephone line cord first, disconnect all cables, and then unplug the power cord from the AC power outlet.
- 3 Unfold the ADF document support (1) and then open the ADF cover (2). Clean the white bar (3) and the scanner glass strip (4) underneath it with a soft lint-free cloth moistened with water. Close the ADF cover (2) and fold the ADF document support (1).

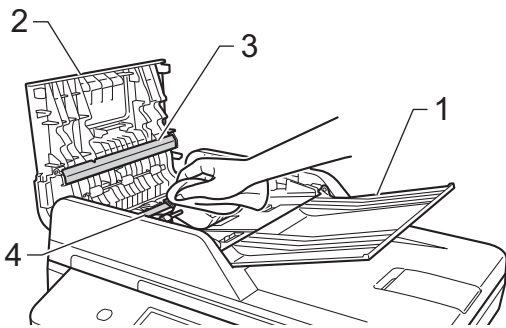

- 4 Lift the document cover (1). Clean the white plastic surface (2) and scanner glass (3) underneath it with a soft lint-free cloth moistened with water.

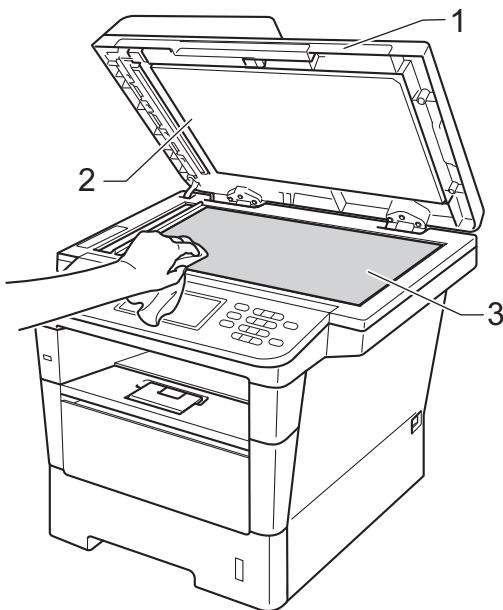

- 5 In the ADF unit, clean the white bar (1) and the glass strip (2) underneath it with a soft lint-free cloth moistened with water.

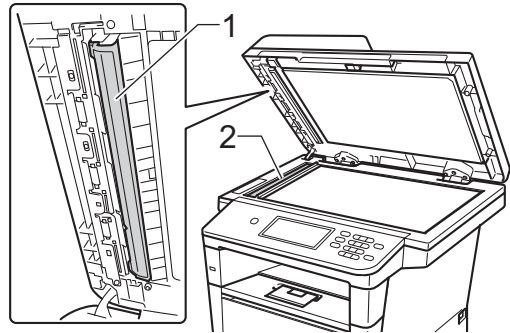

### Note

In addition to cleaning the scanner glass and glass strip with a soft lint-free cloth moistened with water, run your finger tip over the glass to see if you can feel anything on it. If you feel dirt or debris, clean the glass again concentrating on that area. You may need to repeat the cleaning process three or four times. To test, make a copy after each cleaning.

- 6 Close the document cover.
- 7 Plug the machine's power cord back into the AC power outlet first, connect all cables, and then plug in the telephone line cord.
- 8 Turn on the machine's power switch.

## Cleaning the corona wire

If you have print quality problems or the LCD shows **Drum Error**, clean the corona wire as follows:

- 1 Leave the machine turned on for 10 minutes for the internal fan to cool the extremely hot parts inside the machine.
- 2 Press the front cover release button and then open the front cover.

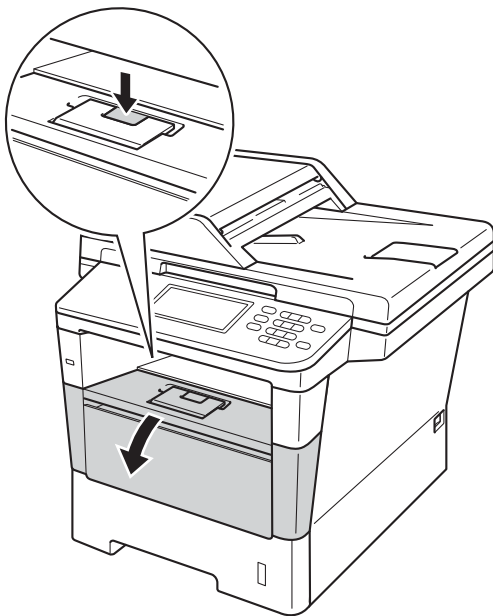

- 3 Take out the drum unit and toner cartridge assembly.

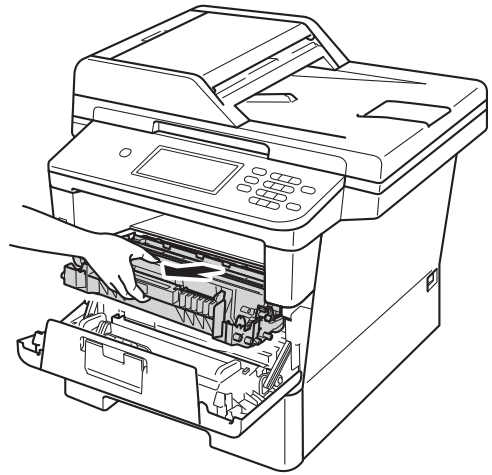

### ! WARNING

#### ! HOT SURFACE

After you have just used the machine, some internal parts of the machine will be extremely hot. Wait for the machine to cool down before you touch the internal parts of the machine.

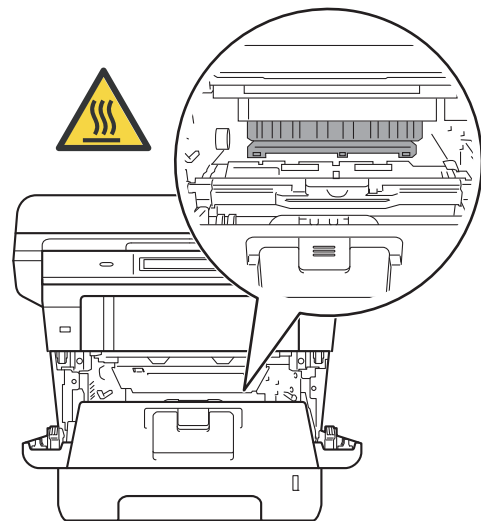

A

## ! Important

- We recommend that you put the drum unit and toner cartridge assembly on a piece of disposable paper or cloth in case you accidentally spill or scatter toner.
- Handle the drum unit and toner cartridge assembly carefully. If toner scatters on your hands or clothes, wipe or wash it off with cold water.
- To prevent damage to the machine from static electricity, DO NOT touch the electrodes shown in the illustration.

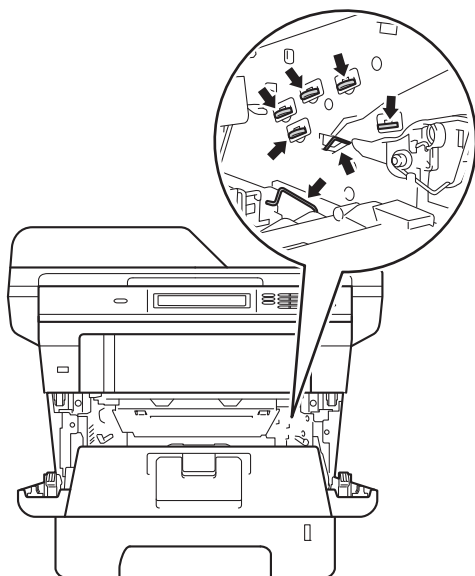

- 4 Clean the corona wire inside the drum unit by gently sliding the green tab from left to right and right to left several times.

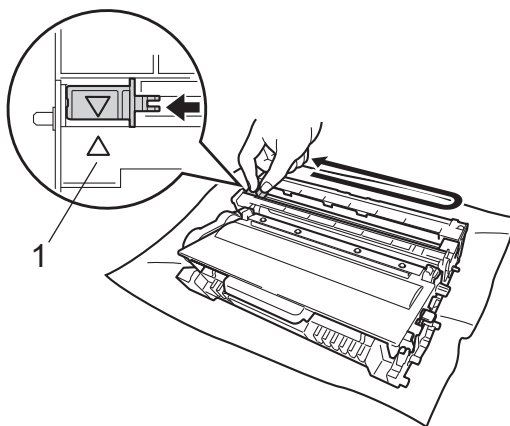

## Note

Be sure to return the tab to the home position (▲) (1). If you do not, printed pages may have a vertical stripe.

- 5 Put the drum unit and toner cartridge assembly back into the machine.

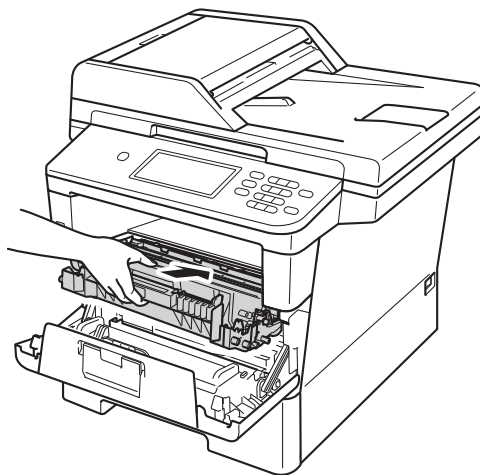

- 6 Close the front cover of the machine.



## Cleaning the drum unit

If your printout has black or white dots or other repeating marks at 3.7 in. (94 mm) intervals, the drum may have foreign material, such as glue from a label stuck on the drum surface. Follow the steps below to solve the problem.

- 1 Make sure that the machine is in the Ready mode.
- 2 Press Menu.
- 3 Press ▲ or ▼ to display Print Reports.  
Press Print Reports.
- 4 Press ▲ or ▼ to display Drum Dot Print.  
Press Drum Dot Print.
- 5 The machine will display Press Start. Press **Start**.
- 6 Leave the machine turned on for 10 minutes for the internal fan to cool the extremely hot parts inside the machine.
- 7 After the machine has cooled down, turn off the machine's power switch.

- 8 Press the front cover release button and then open the front cover.

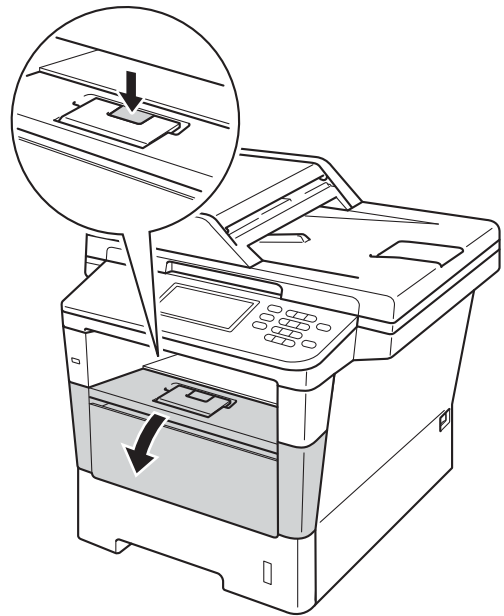

- 9 Take out the drum unit and toner cartridge assembly.

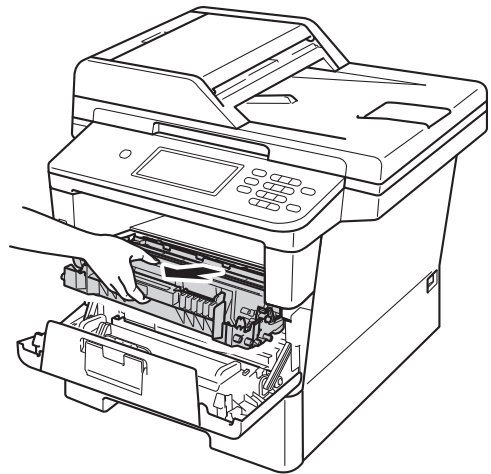

A

## WARNING

### HOT SURFACE

After you have just used the machine, some internal parts of the machine will be extremely hot. Wait for the machine to cool down before you touch the internal parts of the machine.

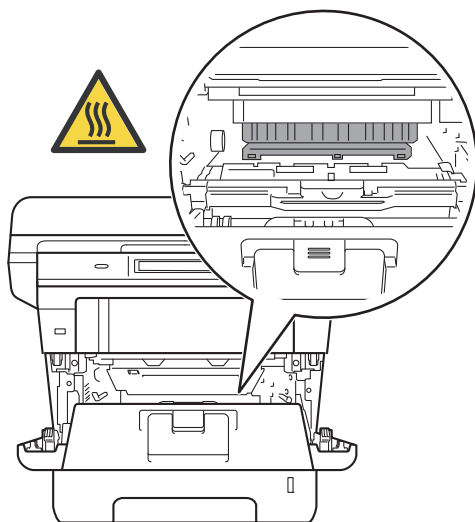

## Important

- We recommend that you put the drum unit and toner cartridge assembly on a piece of disposable paper or cloth in case you accidentally spill or scatter toner.
- Handle the drum unit and toner cartridge assembly carefully. If toner scatters on your hands or clothes, wipe or wash it off with cold water.
- To prevent damage to the machine from static electricity, **DO NOT** touch the electrodes shown in the illustration.

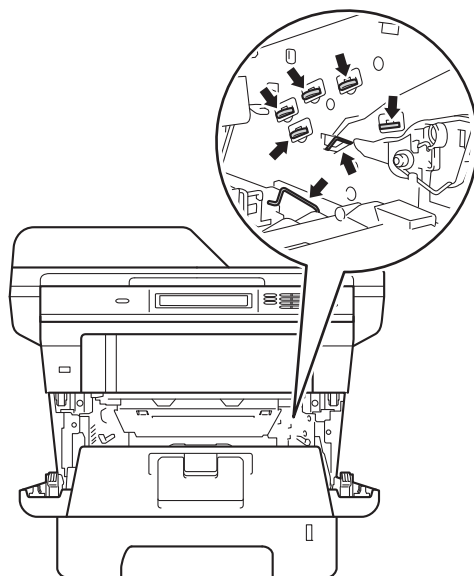

- 10 Push down the green lock lever and take the toner cartridge out of the drum unit.

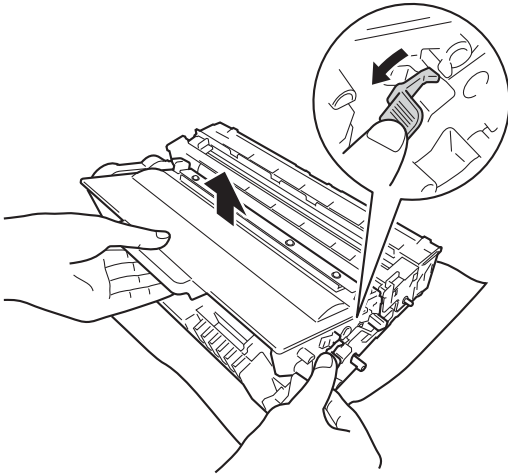

- 11 Turn the drum unit as shown in the illustration. Make sure that the drum unit gear (1) is on the left hand side.

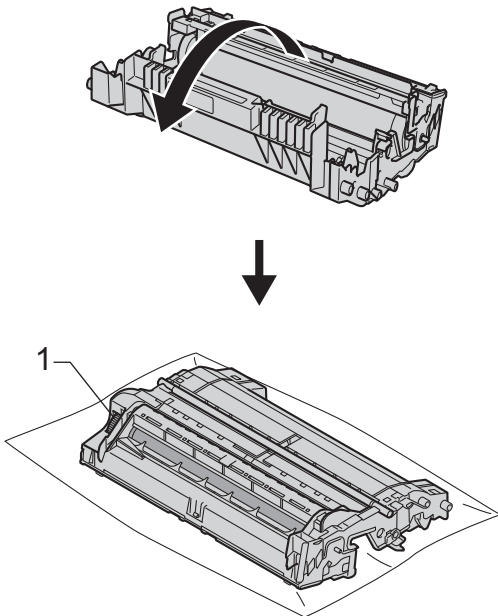

- 12 Use the numbered markers next to the drum roller to find the mark. For example, a dot in column 2 on the check sheet would mean that there is a mark in the "2" region of the drum.

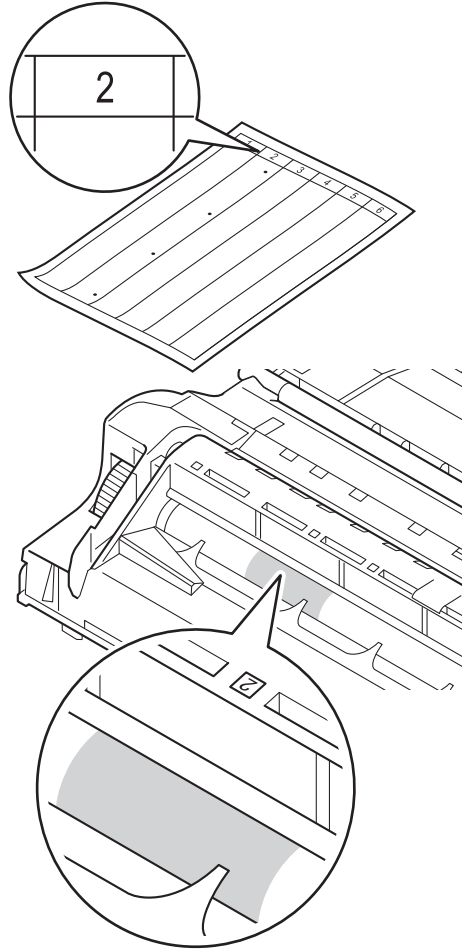

- 13 Turn the drum unit gear toward you by hand while checking the surface of the suspected area.

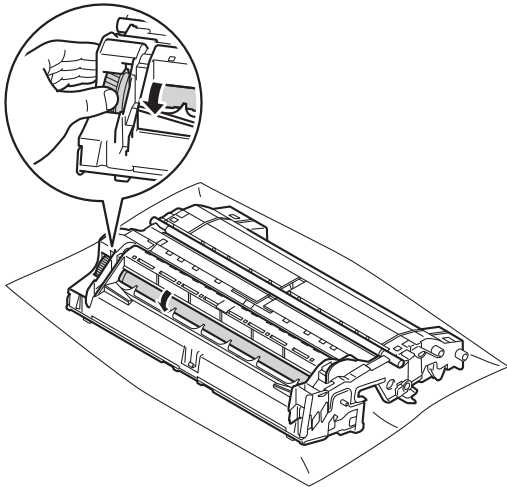

- 14 When you have found the mark on the drum that matches the drum dot check sheet, wipe the surface of the drum gently with a cotton swab until the mark on the surface comes off.

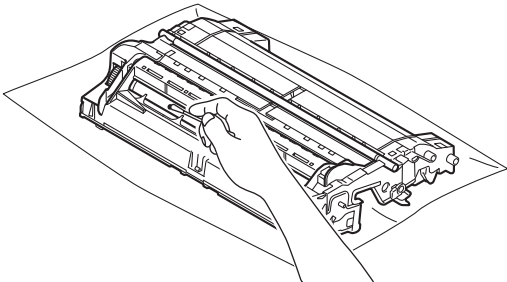

**! Important**

DO NOT clean the surface of the photosensitive drum with a sharp object or any liquids.

- 15 Turn the drum unit back over.

- 16 Put the toner cartridge back into the drum unit until you hear it lock into place. If you put the cartridge in correctly, the green lock lever will lift automatically.

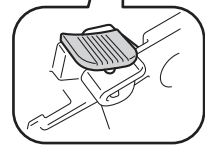
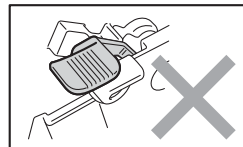
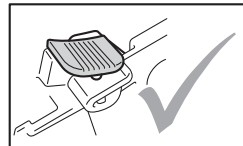
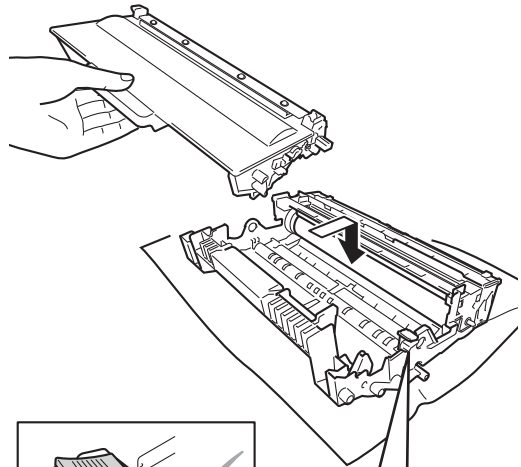

**Note**

Make sure that you put in the toner cartridge correctly or it may separate from the drum unit.

- 17 Put the drum unit and toner cartridge assembly back into the machine.

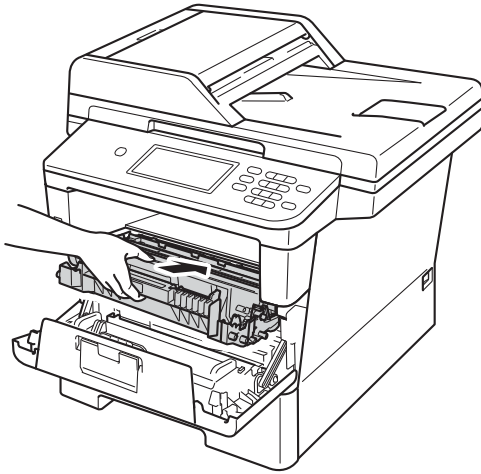

- 18 Close the front cover of the machine.
- 19 Turn on the machine's power switch.

## Cleaning the paper pick-up rollers

Cleaning the paper pick-up roller periodically may prevent paper jams by insuring the proper feeding of paper.

If you have paper feed problems, clean the pick-up rollers as follows:

- 1 Turn off the machine's power switch.
- 2 Unplug the telephone line cord first, disconnect all cables, and then unplug the power cord from the AC power outlet.
- 3 Pull the paper tray completely out of the machine.

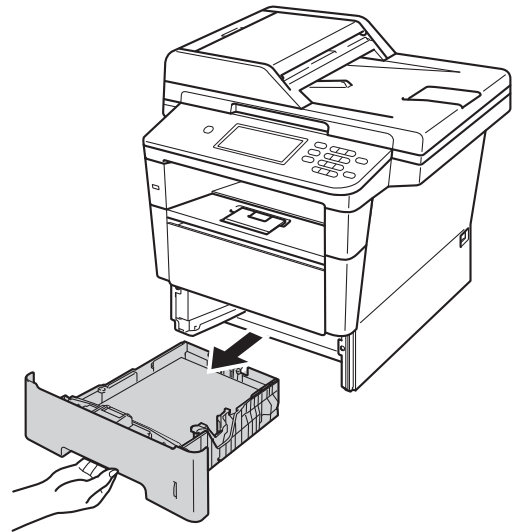

A

- 4 Tightly wring out a lint-free cloth soaked in lukewarm water, and then wipe the separator pad (1) of the paper tray with it to remove dust.

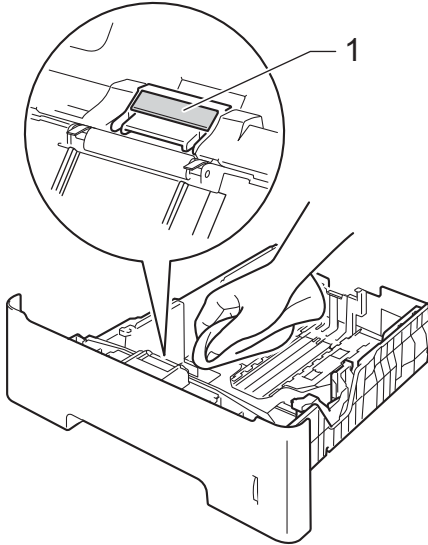

- 5 Wipe the two pick-up rollers (1) inside of the machine to remove dust.

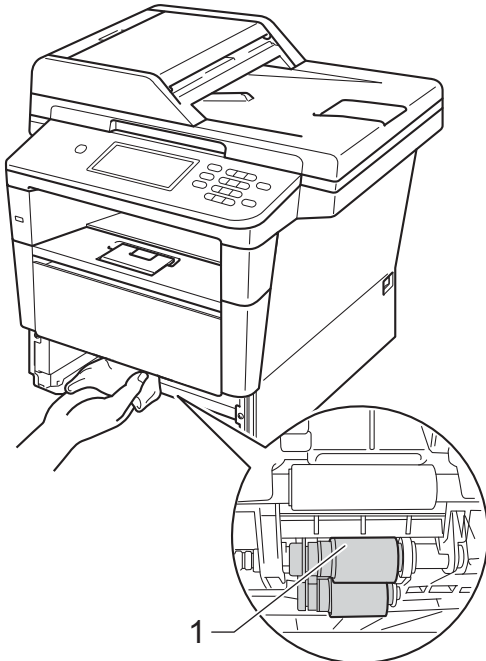

- 6 Put the paper tray back in the machine.

- 7 Plug the machine's power cord back into the AC power outlet first, connect all cables, and then plug in the telephone line cord.

- 8 Turn on the machine's power switch.

## Checking the Page Counters

You can see the machine's Page Counters for copies, printed pages, reports and lists, faxes or a summary total.

- 1 Press **Menu**.
- 2 Press **▲** or **▼** to display Machine Info..  
Press Machine Info..
- 3 Press **Page Counter**.  
The LCD shows number of pages for Total, Fax/List, Copy or Print.
- 4 Press **Stop/Exit**.

## Checking the remaining life of parts

You can see the machine's parts life on the LCD.

- 1 Press **Menu**.
- 2 Press **▲** or **▼** to display Machine Info..  
Press Machine Info..
- 3 Press **Parts Life**.
- 4 Press **▲** or **▼** to see the approximate remaining parts life of the Drum, Fuser, Laser, PF Kit MP, PF Kit 1 and PF Kit 2<sup>1</sup>.
- 5 Press **Stop/Exit**.

<sup>1</sup> When Tray 2 is installed.



### Note

- The life check will be accurate only if you have reset the part counter when you installed a new part. It will not be accurate if that part's life counter was reset during the life of the used part.
- The remaining life of the toner cartridge is listed on the User Settings report. (See *How to print a report* ►► page 51.)

# Replacing periodic maintenance parts

The periodic maintenance parts will need to be replaced regularly to maintain the print quality. The parts listed below will have to be replaced after printing approximately 50,000 pages<sup>1</sup> for PF Kit MP and 100,000 pages<sup>1</sup> for PF Kit 1, PF Kit 2, Fuser and Laser. Please call Brother Customer Service when the following messages appear on the LCD.

LCD message	Description
Replace Parts Fuser Unit	Replace the fuser unit.
Replace Parts Laser Unit	Replace the laser unit.
Replace Parts PF Kit 1	Replace the paper feeding kit for the paper tray.
Replace Parts PF Kit 2 <sup>2</sup>	Replace the paper feeding kit for the lower tray (option).
Replace Parts PF Kit MP	Replace the paper feeding kit for the multi-purpose tray.

<sup>1</sup> Letter or A4 size single-sided pages.

<sup>2</sup> When Tray 2 is installed.



## Packing and shipping the machine

### **⚠ WARNING**

This machine is heavy and weighs more than 39.0 lb (17.7 kg). To prevent possible injuries at least two people should lift the machine. Be careful not to pinch your fingers when you put the machine down.

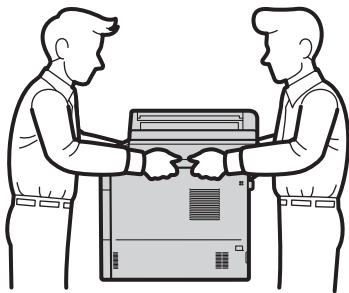

If you use a Lower Tray, DO NOT carry the machine with the Lower Tray as you may be injured or cause damage to the machine because it is not attached to the Lower Tray.

### **Note**

- If for any reason you must ship your machine, carefully repack the machine in the original packaging to avoid any damage during transit. The machine should be adequately insured with the carrier.
- If you are returning your machine to Brother as part of the Exchange Service, pack only the machine. Keep all separate parts, including the drum unit, the toner cartridge, and printed materials to use with your 'Exchange' machine.

- 1 Turn off the machine's power switch. Leave the machine turned off for at least 10 minutes to cool down.
- 2 Disconnect all the cables, and then unplug the power cord from the AC power outlet.
- 3 Put the packing material (1) into the carton.

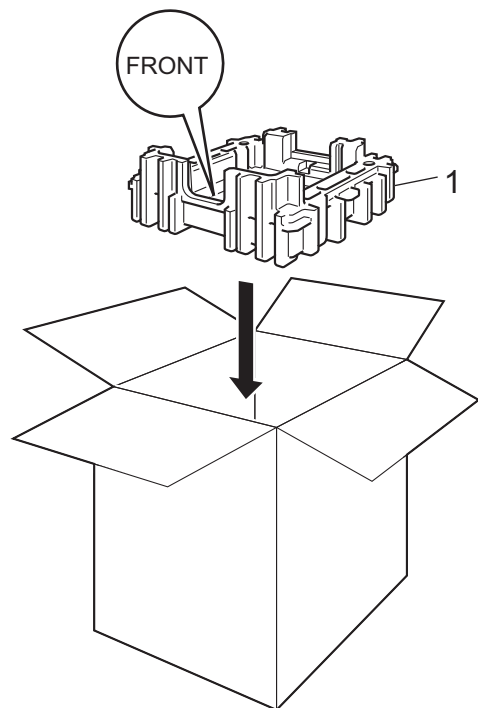

- 4 Wrap the machine in a plastic bag, then put it on the bottom packing material (1).

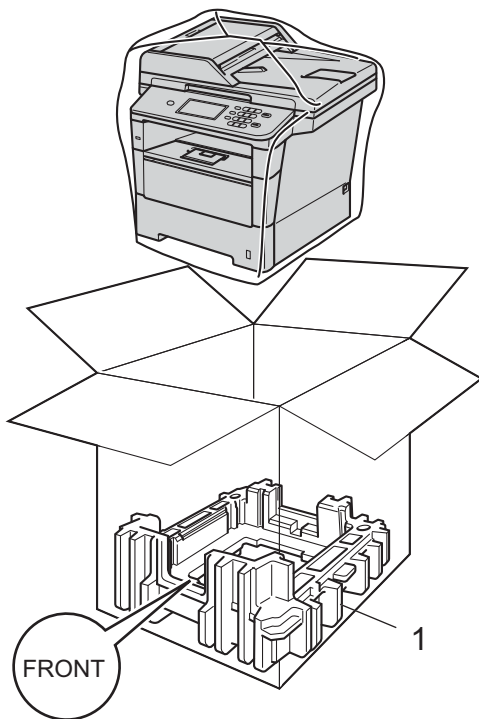

- 5 Put the packing material (2) marked "RIGHT" on the right of the machine. Put the packing material (3) marked "LEFT" on the left of the machine. Put the AC power cord and printed materials in the original carton as shown in the illustration.

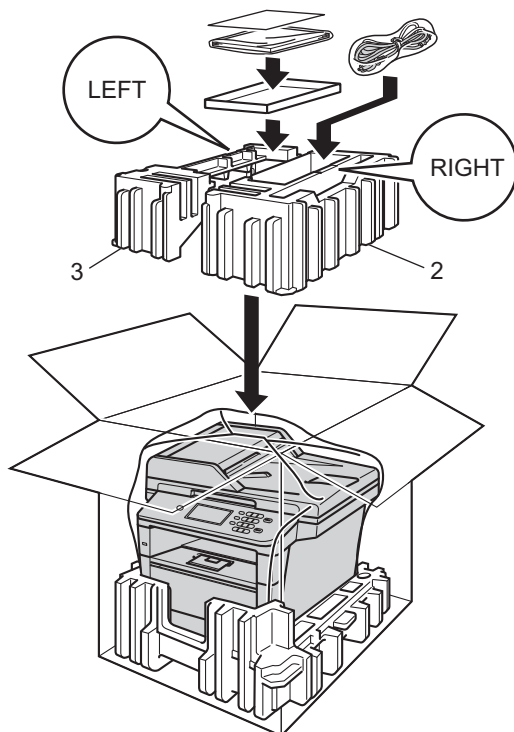

#### Note

If you are returning your machine to Brother as part of the Exchange Service, pack only the machine. Keep all separate parts, including the drum unit, toner cartridge, and printed materials to use with your 'Exchange' machine.

- 6 Close the carton and tape it shut.

- 7 <If you have a Lower Tray>  
Repack the lower tray as shown in the illustration.

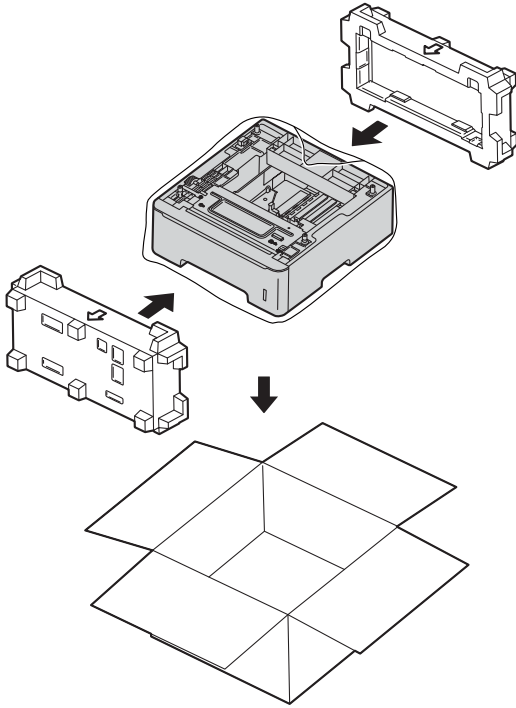

# B

## Options

### Options

This machine has the following optional accessories. You can increase the capabilities of the machine with these items.

#### Lower tray unit <sup>1</sup>

LT-5400

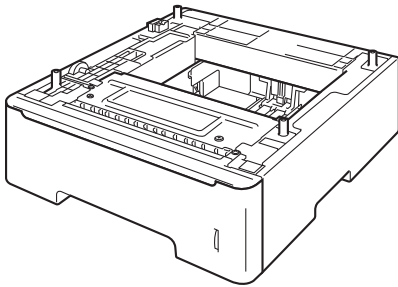

#### SO-DIMM memory

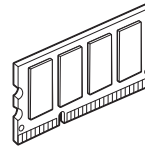

<sup>1</sup> Tray 2 is standard on MFC-8950DWT.

## Optional paper tray (LT-5400)

An optional lower tray can be installed on the MFC-8950DW<sup>1</sup>, and it can hold up to 500 sheets of 20 lb (80 g/m<sup>2</sup>) paper.

When an optional tray is installed, the machine can hold up to 1050 sheets of plain paper.

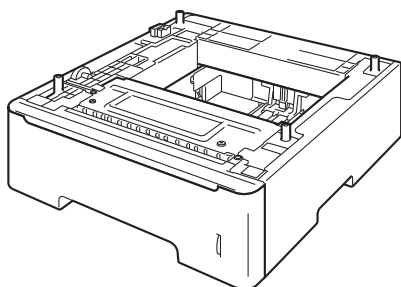

For setup, see the Instructions that we have supplied with the lower tray unit.

<sup>1</sup> Tray 2 is standard on MFC-8950DWT.

### WARNING

If you use a Lower Tray, DO NOT carry the machine with the Lower Tray as you may be injured or cause damage to the machine because it is not attached to the Lower Tray.

## Memory board

MFC-8950DW(T) has 128 MB of standard memory. The machine has one slot for optional memory expansion. You can increase the memory up to maximum of 384 MB by installing one SO-DIMM (Small Outline Dual In-line Memory Module).

### SO-DIMM Types

For information regarding memory for your Brother machine please visit us at:

<http://www.brother-usa.com/support/memory/>.

In general, the SO-DIMM must have the following specifications:

Type	144-pin and 16-bit output
CAS latency	4
Clock frequency	267 MHz (533 Mb/S/Pin) or more
Capacity	256 MB
Height	1.18 in. (30.0 mm)
DRAM type	DDR2 SDRAM



### Note

- There might be some SO-DIMMs that will not work with the machine.
- For more information, call the dealer you bought the machine from or Brother Customer Service.

## Installing extra memory

- 1 Turn off the machine's power switch. Unplug the telephone line cord.
- 2 Disconnect the interface cable from the machine, and then unplug the power cord from the AC power outlet.



### Note

Be sure to turn off the machine's power switch before you install or remove the SO-DIMM.

- 3 Remove the plastic SO-DIMM cover (1).

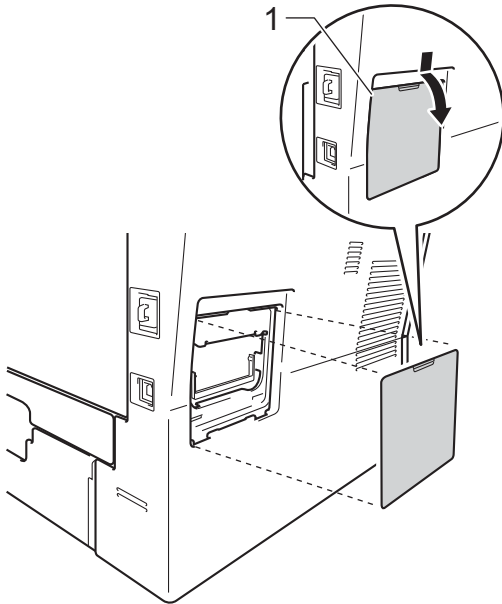

- 4 Unpack the SO-DIMM and hold it by its edges.

### Important

To prevent damage to the machine from static electricity, DO NOT touch the memory chips or the board surface.

- 5 Hold the SO-DIMM by the edges and align the notches in the SO-DIMM with the protrusions in the slot. Insert the SO-DIMM diagonally (1), then tilt it toward the interface board until it clicks into place (2).

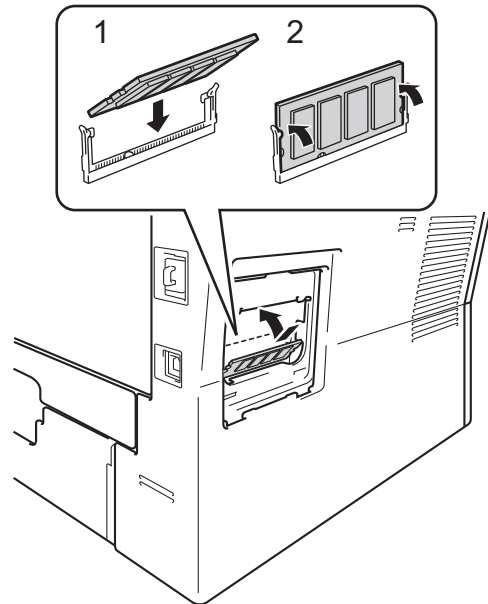

- 6 Put the plastic SO-DIMM cover (1) back on.

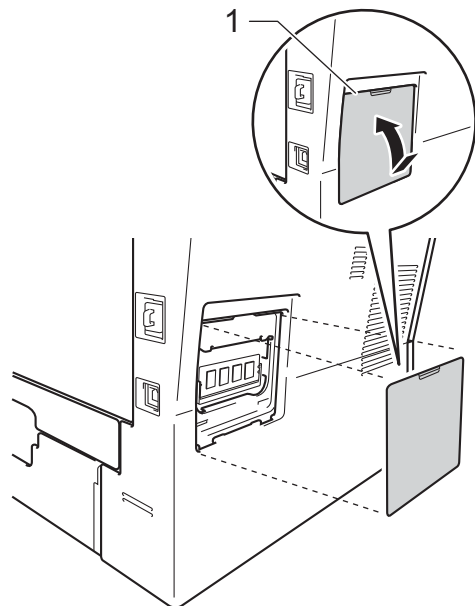

- 7 Plug the machine's power cord back into the AC power outlet first, and then connect the interface cable.
- 8 Plug in the telephone line cord. Turn on the machine's power switch.

**Note**

To make sure that you have installed the SO-DIMM correctly, you can print the User Settings List that shows the current RAM SIZE. (See *How to print a report* >> page 51.)

# C

## Glossary

This is a comprehensive list of features and terms that appear in Brother manuals. Availability of these features depends on the model you purchased.

### **ADF (automatic document feeder)**

The document can be placed in the ADF and scanned one page at a time automatically.

### **Auto Reduction**

Reduces the size of incoming faxes.

### **Automatic fax transmission**

Sending a fax without picking up the handset of the external telephone or pressing **Hook**.

### **Automatic Redial**

A feature that enables your machine to redial the last fax number after five minutes if the fax did not go through because the line was busy.

### **Backup Print**

Your machine prints a copy of every fax that is received and stored in memory. This is a safety feature so you will not lose messages during a power failure.

### **Batch Transmission**

As a cost saving feature, all delayed faxes to the same fax number will be sent as one transmission.

### **Beeper Volume**

Volume setting for the beep when you press a key or make an error.

### **Broadcasting**

The ability to send the same fax message to more than one location.

### **Cancel Job**

Cancels a programmed print job and clears it from the machine's memory.

### **CNG tones**

The special tones (beeps) sent by fax machines during automatic transmission to tell the receiving machine that a fax machine is calling.

### **Coding method**

Method of coding the information contained in the document. All fax machines must use a minimum standard of Modified Huffman (MH). Your machine is capable of greater compression methods, Modified Read (MR), Modified Modified Read (MMR) and JBIG, if the receiving machine has the same capability.

### **Communication error (or Comm. Error)**

An error during fax sending or receiving, usually caused by line noise or static.

### **Compatibility group**

The ability of one fax unit to communicate with another. Compatibility is assured between ITU-T Groups.

### **Contrast**

Setting to compensate for dark or light documents, by making faxes or copies of dark documents lighter and light documents darker.

### **Delayed Fax**

Sends your fax at a specified later time that day.

### **Distinctive Ring**

A subscriber service purchased from the telephone company that gives you another telephone number on an existing telephone line. The Brother machine uses the new number to simulate a dedicated fax line.

### **Dual Access**

Your machine can scan outgoing faxes or scheduled jobs into memory at the same time it is sending a fax or receiving or printing an incoming fax.



**Easy Receive**

Enables your machine to respond to CNG tones if you interrupt a fax call by answering it.

**ECM (Error Correction Mode)**

Detects errors during fax transmission and resends the pages of the fax that had an error.

**Extension telephone**

A telephone on the fax number that is plugged into a separate telephone wall jack.

**External telephone**

A telephone that is plugged into the EXT jack of your machine.

**F/T Ring Time**

The length of time that the Brother machine pseudo/double-rings (when the Receive Mode setting is Fax/Tel) to notify you to pick up a voice call that it answered.

**Fax Forwarding**

Sends a fax received into the memory to another pre-programmed fax number.

**Fax Journal**

Lists information about the last 200 incoming and outgoing faxes. TX means Transmit. RX means Receive.

**Fax Receive Code (Fax/Tel mode only)**

Press this code (\*51) when you answer a fax call on an extension or external telephone.

**Fax Storage**

You can store faxes in the memory.

**Fax tones**

The signals sent by sending and receiving fax machines while communicating information.

**Fax/Tel**

You can receive faxes and telephone calls. Do not use this mode if you are using a telephone answering device (TAD).

**Fine resolution**

Resolution is 203 × 196 dpi. It is used for small print and graphs.

**Gray Scale**

The shades of gray available for copying and faxing photographs.

**Group number**

A combination of One Touch and Speed Dial numbers that are stored on an One Touch button or in a Speed Dial location for Broadcasting.

**Journal Period**

The pre-programmed time period between automatically printed Fax Journal Reports. You can print the Fax Journal on demand without interrupting the cycle.

**LCD (liquid crystal display)**

The display screen on the machine that shows interactive messages during On-Screen Programming and shows the date and time when the machine is idle.

**Manual fax**

When you press **Hook** to hear the receiving fax machine answer before you press **Start** to begin transmission.

**Menu mode**

Programming mode for changing your machine's settings.

**OCR (optical character recognition)**

Nuance™ PaperPort™ 12SE or Presto! PageManager software application converts an image of text to text you can edit.

**One Touch**

Buttons on the machine's Touchscreen where you can store numbers for easy dialing. You can store a second number on each key if you press **\*17-#32** and then press the One Touch button where you want to store the second number.

**Out of Paper Reception**

Receives faxes into the machine's memory when the machine is out of paper.

### **Overseas Mode**

Makes temporary changes to the fax tones to accommodate noise and static on overseas telephone lines.

### **Paging**

This feature enables your machine to call your cell phone or pager when a fax is received into its memory.

### **Pause**

Allows you to place a 3.5 second delay in the dialing sequence while you are dialing using the dial pad or while you are storing One Touch and Speed Dial numbers. Press **Redial/Pause** as many times as needed for longer pauses.

### **Polling**

The process of a fax machine calling another fax machine to retrieve waiting fax messages.

### **Pulse (Canada only)**

A form of rotary dialing on a telephone line.

### **Real Time Transmission**

When memory is full, you can send faxes in real time.

### **Remaining Jobs**

You can check which programmed fax jobs are waiting in the memory and cancel the jobs individually.

### **Remote Access Code**

Your own four-digit code (— —\*) that allows you to call and access your machine from a remote location.

### **Remote Retrieval Access**

The ability to access your machine remotely from a touch tone telephone.

### **Resolution**

The number of vertical and horizontal lines per inch.

### **Ring Delay**

The number of rings before the machine answers in Fax Only and Fax/Tel modes.

### **Ring Volume**

Volume setting for the machine's ring.

### **Scanning**

The process of sending an electronic image of a paper document into your computer.

### **Search**

An electronic, alphabetical listing of stored One Touch, Speed Dial, Group numbers and LDAP.

### **Speed Dial**

A pre-programmed number for easy dialing.

### **Station ID**

The stored information that appears on the top of faxed pages. It includes the sender's name and fax number.

### **TAD (telephone answering device)**

You can connect an external device or answering machine to the EXT. jack of your machine.

### **Telephone Answer Code (Fax/Tel mode only)**

When the machine answers a voice call, it pseudo/double-rings. You can pick up at an extension telephone by pressing this code (**#51**).

### **Tel Index List**

A listing of names and numbers stored in One Touch and Speed Dial memory, in numerical order.

### **Temporary settings**

You can choose certain options for each fax transmission and copy without changing the default settings.

### **Tone**

A form of dialing on the telephone line used for Touch Tone telephones.

### **Transmission**

The process of sending faxes over the telephone lines from your machine to the receiving fax machine.

**Transmission Verification Report**

A report for each transmission, that shows its date, time and number.

**User Settings List**

A printed report that shows the current settings of the machine.

# D

# Index

- 
- A**
- 
- Apple Macintosh  
See Software User's Guide.
- B**
- 
- Broadcasting .....21  
canceling .....22  
setting up Groups for .....45
- C**
- 
- Canceling  
broadcast in process .....22  
fax jobs in memory .....24  
fax storage .....32  
jobs awaiting redial .....24  
remote fax options .....33
- Cleaning  
corona wire .....65  
drum unit .....67  
scanner .....64
- Connecting  
two-line external TAD or telephone .....43
- ControlCenter2 (for Macintosh)  
See Software User's Guide.
- ControlCenter4 (for Windows®)  
See Software User's Guide.
- Copy  
2 in 1 ID Copy .....59  
brightness .....56  
button .....52  
contrast .....56  
duplex .....54  
enlarge/reduce .....53  
N in 1 (page layout) .....57  
quality .....52  
sort .....56  
temporary settings .....52  
using ADF .....57  
using scanner glass .....56, 57, 58
- Cover page .....26  
custom comments .....26  
for all faxes .....27  
printed form .....27
- D**
- 
- Daylight Saving Time ..... 3  
Deep Sleep mode ..... 4  
Delayed batch transmission ..... 24  
Destination Display ..... 28
- Dialing  
access codes and credit card  
numbers ..... 44  
dial prefix ..... 6  
Groups (broadcasting) ..... 21  
restricting dialing ..... 15
- Drum unit  
checking (remaining life) ..... 73  
cleaning ..... 65, 67
- Dual access ..... 20
- Duplex copy ..... 54
- E**
- 
- Enlarge/Reduce ..... 53
- F**
- 
- Fax codes  
changing ..... 33  
remote access code ..... 33
- Fax forwarding  
changing remotely ..... 35, 36  
programming a number ..... 30
- Fax storage ..... 32  
printing from memory ..... 39  
turning off ..... 33  
turning on ..... 32
- Fax, stand-alone  
receiving  
at end of conversation ..... 38  
fax forwarding ..... 30, 36  
fax receive stamp ..... 38  
into memory (fax storage) ..... 32  
paging ..... 31  
polling receive ..... 40  
reducing to fit on paper ..... 37  
retrieving from a remote site ..... 34, 36

sending .....	17
at end of conversation .....	20
broadcasting .....	21
canceling from memory .....	24
contrast .....	18
delayed batch .....	24
delayed fax .....	23
destination display .....	28
from memory (dual access) .....	20
manual .....	19
overseas .....	23
polled transmit .....	29
real time transmission .....	22
resolution .....	19
Fax/Tel mode	
receiving faxes .....	42

## G

Groups for broadcasting .....	45
-------------------------------	----

## H

Hook key .....	42
----------------	----

## J

Jacks	
convert to RJ11 jack	
triple adapter .....	42, 43

## L

LCD (liquid crystal display)	
backlight brightness .....	5

## M

Machine information	
checking remaining life of parts .....	73
page counts .....	73
Macintosh	
See Software User's Guide.	
Maintenance, routine .....	62
checking the remaining life of parts .....	73
Manual	
transmission .....	19
Memory	
adding DIMM (option) .....	79
installing .....	80
storage .....	1

## N

N in 1 (page layout) .....	57
Network	
faxing	
See Software User's Guide.	
printing	
See Network User's Guide.	
scanning	
See Software User's Guide.	
Nuance™ PaperPort™ 12SE	
See Software User's Guide and Help in the PaperPort™ 12SE application to access How-to-Guides.	

## P

Page layout (N in 1) .....	57
Paging .....	31
programming your cell number .....	31
programming your pager number .....	31
PC-Fax	
See Software User's Guide.	
Polling	
polled transmit .....	29
polling receive .....	40
Power failure .....	1
Presto! PageManager	
See Software User's Guide. See also Help in the Presto! PageManager application.	
Print	
fax from memory .....	39
reports .....	51
Printing	
See Software User's Guide.	

## Q

Quality	
copying .....	52
Quick dial	
access codes and credit card	
numbers .....	44
broadcasting .....	21
using Groups .....	21
Group dial	
setting up Groups for broadcasting ...	45
Quiet mode .....	5

Brother International Corporation  
100 Somerset Corporate Boulevard  
P.O. Box 6911  
Bridgewater, NJ 08807-0911 USA

Brother International Corporation (Canada) Ltd.  
1 rue Hôtel de Ville,  
Dollard-des-Ormeaux, QC, Canada H9B 3H6

**brother**®

**Visit us on the World Wide Web**  
**<http://www.brother.com/>**

These machines are approved for use in the country of purchase only. Local Brother companies or their dealers will only support machines purchased in their own countries.

## Free Manuals Download Website

<http://myh66.com>

<http://usermanuals.us>

<http://www.somanuals.com>

<http://www.4manuals.cc>

<http://www.manual-lib.com>

<http://www.404manual.com>

<http://www.luxmanual.com>

<http://aubethermostatmanual.com>

Golf course search by state

<http://golfingnear.com>

Email search by domain

<http://emailbydomain.com>

Auto manuals search

<http://auto.somanuals.com>

TV manuals search

<http://tv.somanuals.com>