

Canon

EOS-1Ds

Mark III DIGITAL

WHITE PAPER



**THE CANON
EOS-1Ds MARK III
CAMERA:**

EOS REBORN

I. OVERVIEW	3
II. SUMMARY OF DIFFERENCES FROM THE EOS-1D MARK III	5
III. SUMMARY OF DIFFERENCES FROM THE EOS-1Ds MARK II	6
Image Quality	6
Speed	6
High Performance	6
Reliability	7
Customization	7
EOS System	7
IV. DISCUSSION OF NEW AND IMPROVED FEATURES	11
New 21.1 Megapixel, Full-Frame CMOS Sensor	11
Autofocus	12
Image Recording and Processing	13
Viewfinder	14
New UDMA Compatibility	16
ISO Speed	16
EOS Integrated Cleaning System	16
Drive	16
Metering and Exposure Control	17
Custom Functions	17
Direct Printing and PictBridge	18
External Flash Control	18
Design and Construction	19
Power Source and Shooting Performance	21
Live View Function	21
Shutter	22
V. ACCESSORIES	23
New EF 14 mm f/2.8L II USM Lens	23
VI. SOFTWARE	25
Lens Aberration Correction Function	25
Brightness Warning Display Function	27
Additional Changes in DPP (Digital Photo Professional)	28
Picture Style Editor	29
VII. SPECIFICATIONS	30
VIII. COMPARISON CHART	35
IX. CONCLUSION	37

I. OVERVIEW

The Canon EOS-1Ds Mark III is a new, top-of-the-line, professional DSLR autofocus camera with a 35mm full-frame, 21.1-megapixel CMOS sensor. It was developed in parallel with the totally new EOS-1D Mark III, so the cameras are similar in many respects. For example, the operation procedure, LCD monitor, menu functions, and playback functions are all the same as those of the EOS-1D Mark III.

The main differences reside in the 35mm full-frame sensor and related features of the EOS-1Ds Mark III, such as the viewfinder optics and the top cover, although other distinctions will be made in this white paper.

EOS-1Ds Mark III: Specifications Different from EOS-1D Mark III

Feature		EOS-1Ds Mark III	EOS-1D Mark III
Sensor size		35mm full-frame	APS-H size
Effective pixels		Approx. 21.10 megapixels	Approx. 10.10 megapixels
Self Cleaning Sensor Unit		Dedicated to full-frame sensor	Dedicated to APS-H size
Pixels recorded	Large	5616 x 3744 (Approx. 21.0 megapixels)	3888 x 2592 (Approx. 10.1 megapixels)
	Medium1	4992 x 3328 (Approx. 16.6 megapixels)	3456 x 2304 (Approx. 8.0 megapixels)
	Medium2	4080 x 2720 (Approx. 11.0 megapixels)	2816 x 1880 (Approx. 5.3 megapixels)
	Small	2784 x 1856 (Approx. 5.2 megapixels)	1936 x 1288 (Approx. 2.5 megapixels)
	RAW	5616 x 3744 (Approx. 21.0 megapixels)	3888 x 2592 (Approx. 10.1 megapixels)
	sRAW	2784 x 1856 (Approx. 5.2 megapixels)	1936 x 1288 (Approx. 2.5 megapixels)
UDMA compatibility (High-speed writing)		Yes	-
ISO speed		100–1600 L:50, H:3200	100–3200 L:50, H:6400
Viewfinder	Magnification (Angle of view)	Approx. 0.76x (Approx. 35°)	Approx. 0.76x (Approx. 28.3°)
Drive modes	High-speed (H)	Approx. 5 fps	Approx. 10 fps
Max. burst	Large	56 shot	110 shot
	RAW	12 shot	30 shot
Metering range	Partial	Approx. 8.5%	Approx. 13.5%
	Spot	Approx. 2.4%	Approx. 3.8%
Flash sync speed		1/250 sec.	1/300 sec.
External flash function settings		Yes (Increased)	Yes
PictBridge		Yes (Increased)	Yes
Battery life (Normal/Low temperature)		1,800 shot / 1,400 shot	2,200 shot / 1,700 shot
Dimensions (W x H x D)		6.1 x 6.3 x 3.1 in. 156 x 159.6 x 79.9mm	6.1 x 6.2 x 3.1 in. 156 x 156.6 x 79.9mm
Weight (Body only)		42.7oz./1,210g	40.7oz./1,155g

* External flash function settings: Zoom and wireless settings added.

* PictBridge: Printing effects are now reflected in the image displayed on the upper left. Tilt correction also added.

When the EOS-1Ds Mark III is compared to the camera it succeeds, the EOS-1Ds Mark II, the differences are much more substantial. The new camera has higher resolution, better image quality (from 14-bit D/A conversion vs. 12-bit, and DIGIC III vs. DIGIC II),

a higher framing rate and larger burst capacity, more precise AF, professional Live View Function, a 3.0-in. LCD monitor (larger images and larger, more legible font size), the EOS Integrated Cleaning System, a more convenient operating system, as well as many other features summarized in the next section.

The EOS-1Ds Mark III is intended, most obviously, for professional studio photographers and landscape photographers, but its 5 fps speed will attract sports, fashion and high-end wedding shooters, too. It is a complete imaging tool, with a host of extraordinary features shared with EOS-1D Mark III and, indeed, the entire Canon EOS System, meaning that almost any photographer for whom ultimate image quality is the benchmark for camera selection will find the EOS-1Ds Mark III deeply appealing. It is a most worthy successor to the EOS-1Ds Mark II.

II. SUMMARY OF DIFFERENCES FROM THE EOS-1D MARK III

- Large size, single-plate, 36 mm x 24 mm (full-frame) CMOS sensor
- Low-noise, wide ISO 100-1600 range* (ISO extension L: 50, H: 3200)
- Compatible with UDMA (Ultra Direct Memory Access) for high-speed writing to the CF card
- 100% viewfinder coverage, 0.76x viewfinder magnification (approximately 35° angle of view), approximately 20mm eyepoint, Ec-C IV standard screen
- Zoom and wireless flash settings added to the Speedlite settings and Speedlite Custom Functions settable using the camera with 580EX II attached
- New PictBridge direct printing effects reflected in the displayed image and image tilt correction now provided
- The EOS-1Ds Mark III is 0.12 in./3mm taller and 1.76 oz./50g heavier than the EOS-1D Mark III

*Standard output sensitivity. Recommended exposure index.

III. SUMMARY OF DIFFERENCES FROM THE EOS-1Ds MARK II

Image Quality

- 21.1 effective megapixels for ultra-fine resolution and top image quality
- Dual “DIGIC III” Image Processor with DDR-SDRAM buffer for fine-detail and natural color reproduction with high-speed processing of very large files
- Picture Styles for image control according to the preferences and intentions of the photographer
- RAW, sRAW (Small RAW), RAW+JPEG, sRAW+JPEG simultaneous recording
- 5 custom WB settings can be registered
- 6 preset settings, color temperature specification, and personal WB
- WB correction and WB bracketing provided
- Noise reduction provided for long exposures
- Noise reduction provided for high ISO speed images
- Highlight Tone Priority

Speed

- Maximum speed approximately 5 fps continuous shooting (One-Shot AF, AI SERVO AF, switchable between H [High-speed continuous] and L [Low-speed continuous])
- Maximum burst, JPEG Large, approximately 56 shots; RAW, approximately 12 shots
- Fast startup time of approximately 0.2 sec.
- Shutter release time lag approximately 55 msec.; viewfinder blackout time approximately 80 msec. (with C.Fn IV-13-1, approximately 40 msec. at max. aperture)
- Compatible with SDHC (SD High-Capacity) memory cards, plus 2GB and higher capacity CF and SD memory cards
- Compatible with USB 2.0 Hi-Speed image transfer to personal computer

High Performance

- New Area AF sensor with 19 high-precision, cross-type AF points + 26 Assist AF points
- 19 points: Cross-type focusing with f/2.8 or faster lenses
- 26 points: Horizontal line-sensitive focusing with f/5.6 or faster lenses
- Center AF point: Horizontal line-sensitive focusing with f/8 or faster lenses
- AF points can be set to the inner or outer 9 AF points
- AF microadjustment provided (fine adjustment of AF point of focus)
- For AI SERVO AF, the AF operation characteristics, AF point selection characteristics, and focus-tracking sensitivity can be adjusted
- During manual AF point selection, AF point area is expandable
- Switch to registered AF point is possible (Home Position function)
- High-magnification viewfinder and improved focusing screen with 100% viewfinder coverage, 0.76x viewfinder magnification (approx. 35° angle of view), approx. 20mm eyepoint
- Ec-C IV standard screen and compatible with Ec-type focusing screens used by EOS-1
- EOS Integrated Cleaning System with Self Cleaning Sensor Unit, Dust Delete Data acquisition and appending enabled

- 63-zone metering sensor for more stable ambient and flash metering
- Remote Live View Function and (camera) Live View Function provided with displayable exposure simulation and aspect ratio information
- Large and very bright 3.0-in. LCD monitor with 230,000 pixels and wide angle of view
- High-capacity lithium-ion battery with battery check detection and battery information viewable with the menu
- Compact and lightweight battery helps make the EOS-1Ds Mark III 5.82 oz./165g lighter and easier to carry
- Flexible recording options: automatic switching of recording media, separate recordings to media, identical recordings to multiple media
- Silent mode (for one image) provided
- ISO speed always displayed, and ISO speed safety shift provided
- Standard EOS Digital camera control operation incorporated with SET button and Multi-controller provided for refined convenience
- Displayable camera settings and better image information during playback, including histogram display, jump display, error code display, and shooting functions display (C.Fn II-9)

Reliability

- Shutter durability of approximately 300,000 cycles
- Chassis, mirror box, and exterior covers made of magnesium alloy for a lightweight and highly rigid body
- Maintains dust- and water-resistance of Speedlite 580EX II
- With the 580EX II and a dust- and water-resistant lens attached, entire camera is resistant to dust and water



Customization

- 57 Custom Functions in four groups
- Personal Functions consolidated with Custom Function
- Custom Function settings can be registered and called up
- My Menu can be registered and displayed at the start
- Camera settings can be saved and read
- Camera's basic settings can be registered and applied



EOS System

- External recording media and GPS unit usable (via WFT-E2A)
- Speedlite settings and Speedlite Custom Functions settable with the camera (with 580EX II attached)
- Image encryption/decryption possible (with OSK-E3)
- Direct image transfer enabled
- Camera direct printing (PictBridge) improved and DPOF print ordering provided

Specifications Comparison of EOS-1Ds Mark III and EOS-1Ds Mark II



Item/Camera		EOS-1Ds Mark III	EOS-1Ds Mark II	
External appearance				
Image sensor	Image sensor	CMOS		
	Image sensor size [mm]	36 x 24mm full-frame	36 x 24mm full-frame	
	Effective pixels [Approx. megapixels]	21.10	16.70	
	Pixel size [µm square]	6.4	7.2	
	Lens Crop Factor [Approx. magnification]	1.0	1.0	
	Color filter	Primary colors		
	Self Cleaning Sensor Unit	Yes (Dedicated to full-frame)	–	
	Sensor Cleaning	Auto Cleaning	Yes	–
		Clean now	Yes	–
		Clean manually	Yes	
Dust Delete Data	Yes	–		
Imaging engine	Dual "DIGIC III"	DIGIC II		
A/D conversion [bits]	14	12		
Recording media	CF (MD), SD, external media (via WFT-E2A)	CF(MD), SD		
Slots	2 (CF: 1, SD: 1)			
Compatible card capacity	2 GB and higher (compatible with SDHC)	2 GB and higher (compatible with SDHC/Ver.1.16 or later)		
UDMA (Ultra Direct Memory Access) Compatible	Yes	–		
Recording format	Design rule for Camera File System 2.0, Exif2.21			
Image size [Approx. megapixels/MB]	JPEG	Large	5616 x 3744 (21.00/6.4)	
		Medium1	4992 x 3328 (16.60/5.2)	
		Medium2	4080 x 2720 (11.00/3.9)	
		Small	2784 x 1856 (5.20/2.2)	
	RAW	5616 x 3744 (21.00/25.0)	4992 x 3328 (16.00/4.6)	
RAW+JPEG simultaneous recording	sRAW (Small RAW)	2784 x 1856 (5.20/14.5)	–	
	RAW+JPEG	Yes		
Recording functions	sRAW+JPEG	Yes	–	
	Auto switch media	Yes (CF → SD → External media)	–	
	Rec. separately	Yes (CF/SD/External media)	–	
Rec. to multiple	Yes (CF/SD/External media)	Yes (CF/SD)		
Color space	sRGB, Adobe RGB			
Picture Styles [types]	Yes (Preset: 6, User-defined: 3)	Color matrix + Processing parameters		
File name setting [Characters]	Assigned by camera	Yes		
	User setting 1	Yes (4 characters)	–	
	User setting 2	Yes (3+1 characters: Image size appended automatically)	–	
File No.	Continuous / Auto Reset / Manual Reset			
Noise reduction of long exposures	Yes (Off/Auto/On/C.Fn II -1)	Yes (Off/On)		
Noise reduction of high ISO shots	Yes (C.Fn II -2)	–		
Highlight tone priority	Yes (C.Fn II -3)	–		
Image copying between recording media	Yes	–		
Backup to external media	Yes (Via WFT-E2A, Quick and Normal)	–		
White Balance	Detection system	Image sensor		
	Auto WB	Yes		
	Preset WB [types]	1. Daylight / 2. Shade / 3. Cloudy, Twilight, Sunset 4. Tungsten light / 5. White Fluorescent light / 6. Flash		
	Custom WB	Registered	5	1
		Images in card → Registered	Yes	
	Shooting → Registered	Yes	–	
	Personal WB	Yes (5)	Yes (3)	
	Color Temp. Spec. [Range/Increments]	Yes (2500-10000/100)	Yes (2800-10000/100)	
WB correction	YES (B/A/M/G: 9 / UI improved)	YES (B/A/M/G: 9 / G:9)		
WB bracketing	Yes (B/A, M/G: ±3 levels in 1-level increments / UI improved)	Yes (B/A, M/G: ±3 levels in 1-level increments)		
Viewfinder	Coverage [Approx. %]	100		
	Magnification [Approx. magnification] (Angle of view [Approx.])	0.76 (35°)	0.70 (31.9°)	
	Eye point [mm]	20		
	Dioptic adjustment [dpt]	Yes (-3 - +1)		
	Viewfinder blackout time [Approx. ms, Tv = 1/60 sec. or faster]	80	87	
	Indicators	ISO speed always displayed	Yes	–
		Metering mode	Yes	–
		Image size	Yes (RAW, JPEG)	Yes (JPEG only)
		Battery check	Yes	–
	Depth-of-field preview	Yes		
	Eyepiece shutter	Yes (Gray blades)	Yes	
	Standard focusing screen [Overall characteristics]	Ec-C IV (Yes + Advanced features)	Ec-C III (Yes)	
	Interchangeable focusing screens	Yes	Yes (Ec-C IV and Ec-S incompatible)	

Specifications Comparison of EOS-1Ds Mark III and EOS-1Ds Mark II (cont.)

Item/Camera		EOS-1Ds Mark III	EOS-1Ds Mark II	
External appearance				
Autofocus	AF Points	Cross-type AF points	19 (f/2.8 for horizontal + f/5.6 for vertical)	
		Assist AF points	26 (f/5.6 for vertical)	
		Total AF points	45	
	Superimposed display		Yes	
	AF mode	One-Shot	Yes	
		AI SERVO	Yes	
		Manual	Yes	
		Focusing brightness range [EV at 23°C/73°F, ISO 100]	-1 - 18	0 - 18
	AF point selection		Auto/Manual	
	AF point area expansion		Yes (C.Fn III -8)	Yes (C.Fn-17)
	AF point selection method change in AI SERVO AF		Yes (C.Fn III -4)	-
	Operation & release timing change in AI SERVO AF		Yes (C.Fn III -3)	-
AF Microadjustment		Yes (C.Fn III -7)	-	
Switch to registered AF point		Yes (C.Fn III -10, C.Fn III -6-6)	Yes (C.Fn-18)	
50 kph predictive AF [EF300mm f/2.8L IS USM, approx. m]		8		
Exposure Control	Sensor Zones		63	
	Focusing brightness range [EV at 23°C/73°F, ISO 100]		0 - 20	
	Metering Modes	Evaluative	Yes	
		Partial [%]	Yes (8.5)	
		Spot [%]	Yes (2.4/C.Fn I -7)	Yes (2.4/C.Fn-13)
		Multi-spot	Yes (8)	
		Center-weighted average	Yes	
	ISO Speed	Setting range [ISO, step]	100 - 1600 (1/3)	
		ISO extension [ISO]	-> (C.Fn I -3)	Yes (L: 50, H: 3200)
		ISO safety shift	Yes (C.Fn I -8)	-
	Shooting Modes	Program AE	Yes	
		Shutter-priority AE	Yes	
		Aperture-priority AE	Yes	
		Manual exposure	Yes	
		Bulb	Yes	
	AE Lock		Yes	
	Exposure Compensation [increments and range]		1/3*±3	
AEB [increments and range]	Tv/Av	Yes (1/3*±3)		
	ISO	-	Yes	
Shutter	Type			
	Vertical-run, focal-plane, mechanical shutter with all speeds electronically controlled			
	Speeds [sec.]		1/8000 - 30, bulb	
	Max. sync speed [sec.]		1/250	
	Release time lag [Halfway press -> Full press in ms]		55 (40 at optimum)	
	Shutter Durability [Approx.]		300,000	200,000
Drive	Drive Modes	Silent	Yes	
		Single	Yes	
		Continuous [approx. fps]	High-speed: 5, Low-speed: 3	
		Self-timer [sec.]	10, 2	
	Continuous shooting [Max. approx. fps]		5	4
	Max. Burst [Approx. shot]	JPEG	56	32
		RAW	12	11
RAW+JPEG Large		10	9	
Mirror lockup		Yes (C.Fn III -15/Continuous shooting enabled)	Yes (C.Fn-12)	
External Flash	Flash metering		E-TTL II	
	Evaluative/Averaged flash metering		Yes (C.Fn II -4)	
	TTL II		Yes (C.Fn-14)	
	FE lock		Yes	
	Flash exposure compensation [increments/amount]		1/3*±3	
	FEB		Yes (Settable with camera/Speedlite)	Yes (Settable with Speedlite)
	2nd-curtain sync		Yes (Settable with camera/Speedlite)	
	Speedlite settable with camera		Yes (Zoom and wireless features added)	
Live View Function Shooting	Speedlite Custom Functions settable		Yes	
	Remote Live View Function shooting		Yes (EOS Utility)	
	-(Live View Function shooting impossible, shooting and image transfer only)		-	
	(Camera) Live View Function shooting		Yes	
	Grid display		Yes	
	Exposure simulation		Yes (C.Fn IV -16)	
Aspect ratio indicator/info appended		Yes (C.Fn IV -14)		
LCD Monitor	Screen Size [in.]		3.0	
	Pixels displayed [Approx.]		230,000	
	Angle of view [°]	Vertical	140 (70/70)	(Undisclosed)
		Horizontal	140 (70/70)	(Undisclosed)
	Max. brightness		Yes (brighter)	Yes
	Brightness adjustment [Levels]		Yes (7, Gray chart)	Yes (5, Gray chart)
Character size		Yes (larger)	Yes	
Operation ease	Shooting settings		Button (Timer) -> Main/Quick Control Dial	
	Menu selection		Main Dial/Quick Control Dial -> SET button	
	MENU / SELECT+ Quick Control Dial		-	
	AF point selection		Main Dial/Quick Control Dial (Multi-controller:Center/ Auto AF point selection only)	
	Main Dial/Quick Control Dial		-	
AF start/ISO speed setting/Function button		Yes / Yes / Yes	-	
Multi-controller		Yes	-	

**Specifications Comparison
of EOS-1Ds Mark III and
EOS-1Ds Mark II
(cont.)**

Superior specifications

Item/Camera		EOS-1Ds Mark III	EOS-1Ds Mark II	
External appearance				
Menus & Customization	Category	Shooting1,2/Playback1,2/Set-up1,2,3 /Custom Functions/My Menu	Shooting/Playback/Set-up 1,2/ Custom, Personal Function	
	Interface Languages	18	12	
	Customization	Custom Functions [Types]	57 (I:15, II:9, III:17, IV:16)	20
		Personal Functions	Consolidated with Custom Functions	27
		Registration/call-up of setting groups	Yes (Set 1 - 3)	Yes (P.Fn-00: 3)
	Save/read camera settings with card	Yes (10)	Yes (1)	
	Register camera settings	Yes (Menu)	Yes (P.Fn-25)	
	My Menu registration	Yes (6)	-	
Menu operation during image processing/writing	Yes			
Playback	Single image display [Types]	1. Single image, 2. Single image + image size, 3. Shooting information, 4. Histogram (Brightness + RGB)	1. Single image 2. Shooting information	
	Index display [Images]	Yes (4, 9)		
	Zoom-in magnification	Magnification [Approx.]/Steps	1.5 - 10 / 15	
		Initial magnified position	Center / User-selected AF point	-
	Image jump [Types]	Yes (6)	-	
	Histogram	Yes (Brightness / RGB)		
	Highlight alert	Yes		
	AF point display	Yes		
	Auto rotate vertical image	Yes (Camera / PC)	Yes (Camera)	
	Rotate image [°]	Yes (90-270-0)		
	Protect image	Yes (Single image: 2 ways, folder, card)	Yes (Single image, folder, card)	
	Erase image	Yes (Single image: check, folder, card)	Yes (Single image, folder, card)	
	Sound recording [sec.]	Yes (30)		
Low-level format	Yes (SD card only)	-		
Camera Direct/DPOF	PictBridge (PTP) Compatibility	Yes + Advanced features (Printing effects reflected in displayed image and tilt correction added)	Yes	
	CP/BJ Direct Compatibility	-	Yes	
	DPOF [Ver.]	Yes (1.1)		
Direct image transfer/Transfer order		Yes / Yes	-	
Interface	IEEE1394	-	Yes (Protector provided)	
	USB2.0 Hi-Speed	Yes (Protector provided)	-	
	Extension system terminal	Yes	-	
	Direct printing terminal (USB)	-	Yes	
	Video OUT	Yes (NTSC/PAL)		
	Remote Control Terminal [Type]	Yes (N3)		
	PC Terminal	Yes		
	Extension system terminal	Yes	-	
Wireless/wired LAN compatibility		Yes + Advanced features (WFT-E2A)	Yes (WFT-E1A)	
External media connection		Yes (via WFT-E2A)	-	
GPS device compatibility		Yes (via WFT-E2A)	-	
Original image verification data		Yes (C.Fn IV -15)	Yes (P.Fn-31)	
Image encryption		Yes (OSK-E3)	-	
Power Source	Battery (Capacity, mAh)	Dedicated Li-ion battery (2300)	Dedicated Ni-MH battery (NP-E3: 1650)	
	Number of shots [At 23°C/73°F] (CIPA)	1800/1400	1200/800	
	Battery information	Remaining capacity detection	Yes (1% increments)	-
		Recharge performance	Yes (3 levels)	-
		Shutter count	Yes	-
	AC drive	Yes (ACK-E4)	Yes (DCK-E1)	
Backup battery for date/time	CR2025			
Exterior	Main materials (Body, covers, mirror box)	Magnesium	Magnesium and aluminum	
	Exterior color	Black		
	Dust- and water-resistance	Yes (Suited for water-resistant Speedlite)	Yes	
	Canon logo	Relief letters with white filling		
	LCD panel	Top/Rear illumination	Yes/Yes	
		Yes		
Startup time [Approx. sec.]		0.2	0.3	
Dimensions [W x H x D]		6.1 x 6.3 x 3.1 in./156 x 159.6 x 79.9 mm	6.1 x 6.2 x 3.1 in./156 x 157.6 x 79.9 mm	
Weight [Approx. g]	Body only	42.7oz./1,210g	42.9oz./1,215g	
	Including battery and eyecup (excludes body cap)	1,400g	1,550g	
Operation Environment	Ambient temperature	0 - 45°C/32-113°F		
	Ambient humidity [% or less]	85		
Marketing Date		Fall 2007	2004.11	

IV. DISCUSSION OF NEW AND IMPROVED FEATURES

New 21.1 Megapixel, Full Frame CMOS Sensor

The 35mm full-frame CMOS sensor of the EOS-1Ds Mark III has been developed and manufactured by Canon. Its 6.4µm pixels take advantage of a host of Canon R&D advances to achieve its speed, resolution and image quality. The following features make the EOS-1Ds Mark III the highest performing digital AF SLR camera:

- 35mm full-frame digital AF SLR with the world's highest resolution, approximately 21.1 megapixels*
- Wide ISO speed range (ISO 100- 1600, L: 50, H: 3200)
- Low noise (same level as EOS-1Ds Mark II)
- High-speed signal reading (approximately 5 fps)
- Low power consumption
- Live View Function

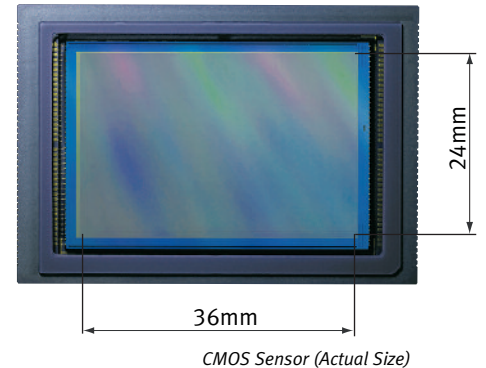

*For 24x36mm format as of August 20, 2007.

Although the pixel size is about the same as that of the EOS 30D, the ISO speed range is the same as that of the EOS-1Ds Mark II.

	Pixel size [µm square]	ISO speed range
EOS-1Ds Mark III	6.4	50 L 100 - 1600 H 3200
EOS-1Ds Mark II	7.2	50 L 100 - 1600 H 3200
EOS 5D	8.2	50 L 100 - 1600 H 3200

By optimizing the gap between the on-chip microlenses, reducing the height from the photodiode to the microlens, and improving the fill factor (photo diode area divided by pixel size) by applying the micro-rule that improves the performance of the exposure device, light-gathering efficiency has been improved.

Opening Ratio (Conceptual Diagram)

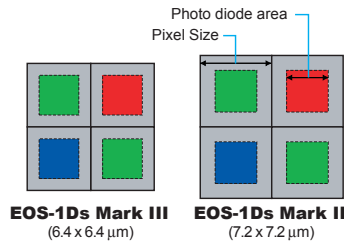

Microlens Comparison (Conceptual Diagram)

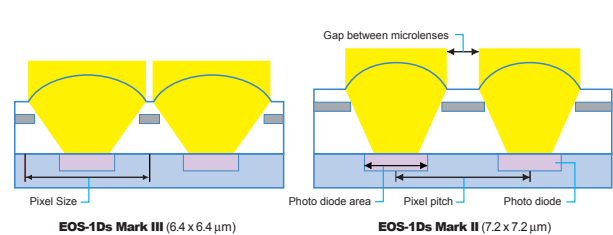

Also, the second-generation, on-chip noise removal circuit and a newly-developed noise reduction technology combine to remove noise effectively. To achieve even less noise, the EOS-1Ds Mark III has a new output amp that attains both high speed and low noise. Low noise is also achieved with an improved manufacturing process, optimized pixel amp, and optimized reading circuit.

Diagram of 8-channel Signal Reading

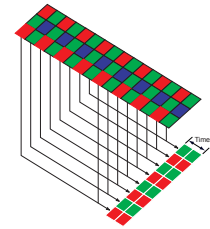

Thanks to optimized photo diode construction and finer processing, the photo diode can still accumulate enough light to function exceptionally well. At low ISO speeds, the dynamic range is about the same as that of the EOS-1Ds Mark II.

As with the EOS-1D Mark III, single-line, 8-channel parallel reading is employed. With a low-noise, high-speed output amp, a continuous shooting speed of approximately 5 fps is attained, even with approximately 21.1 megapixels with which to contend.

LPF Construction

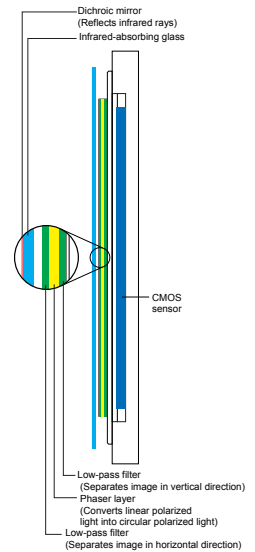

The infrared, low-pass hybrid filter in front of the sensor consists of an infrared-absorption glass (including multiple coatings to reflect ultraviolet and infrared rays) and low-pass filter (phase plate sandwiched by two single-crystal plates). Other than optimization for the full-frame CMOS sensor, the specifications are the same as for the EOS-1D Mark III.

Autofocus

The state-of-the-art AF sensor in the EOS-1Ds Mark III is shared with the EOS-1D Mark III. The AI SERVO AF algorithm has been optimized to match the continuous shooting speed of the EOS-1Ds Mark III, approximately 5 fps. Also, due to the full-frame CMOS sensor, the Area AF coverage with respect to the viewfinder is slightly smaller than with the EOS-1D Mark III. The AF speed and predictive AF performance are the same as with the EOS-1D Mark III. All other AF-related specifications not mentioned here are also the same as the best-in-class EOS-1D Mark III.

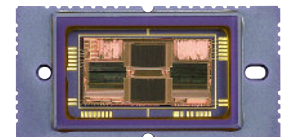

AF Sensor

AF Sensor Configuration

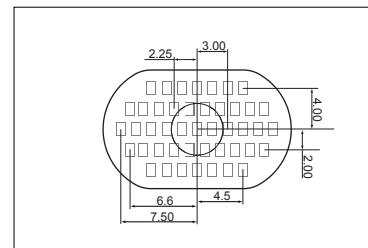
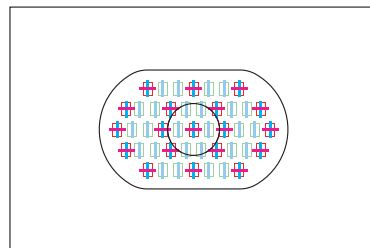

- : Cross-type AF points □: Assist points (Not user-selectable)
- : f/2.8 sensors (Center AF point is f/4)
- : f/5.6 sensors

With the EF 24mm f/2.8 or EF 28mm f/2.8 lens, cross-type focusing will be active with the 13 AF points shown in the diagram; the remaining 6 AF points will be horizontal line-sensitive at f/5.6. All other EF lenses take full advantage of the AF sensor.

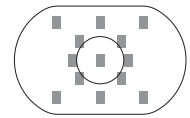
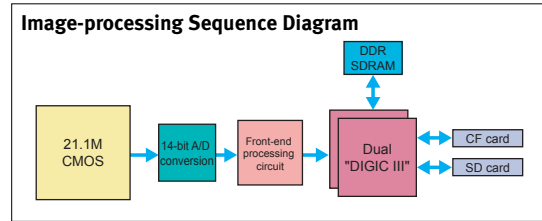
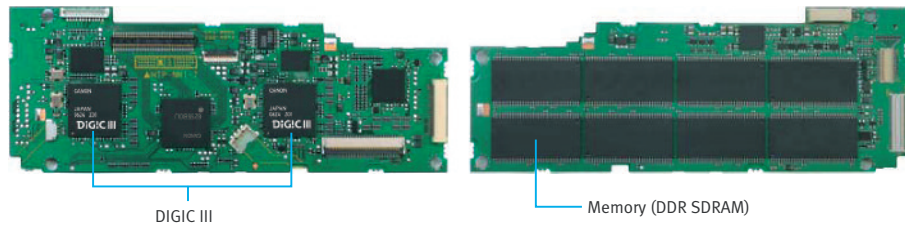

Image Recording and Processing

All basic specifications related to image processing such as Dual “DIGIC III” Image Processors, 14-bit A/D conversion, and DDR SDRAM are the same as those of the EOS-1D Mark III.



Digital Control Circuit Board



The number of pixels for all image sizes is about double that of the EOS-1D Mark III. The recorded resolution can be set to any one of six sizes. For JPEGs, the compression rate can be set to one of 10 settings for each image size, a feature shared with the EOS-1D Mark III. The sRAW or Small RAW setting that was originally introduced with the EOS-1D Mark III becomes even more useful with the EOS-1Ds Mark III, since the resolution in sRAW is 5.3 megapixels with the new camera.

Recording Quality Specifications

Image size	Pixels [Approx. megapixels]	File Size [Approx. MB/ Shot]	Possible Shots [Approx.]	Maximum burst [Approx.]		Printing Size	
				High-speed	Low-speed		
L	21.10 (5616 x 3744)	6.4	290	56 (63)	83 (180)	A2 or larger	
M1	16.60 (4992 x 3328)	5.2	350	73 (96)	140 (370)	Around A2	
M2	11.00 (4080 x 2720)	3.9	470	110 (160)	300 (500)	Around A3	
S	5.20 (2784 x 1856)	2.2	840	160 (470)	890 (890)	Around A4	
RAW	21.10 (5616 x 3744)	25.0	75	12 (12)	14 (16)	A2 or larger	
RAW+	L	-	25.0 + 6.4	54	10 (10)	10 (10)	-
	M1		25.0 + 5.2	57	10 (10)	10 (10)	
	M2		25.0 + 3.9	60	12 (12)	12 (12)	
	S		25.0 + 2.2	64	12 (12)	12 (12)	
sRAW	5.20 (2784 x 1856)	14.5	130	18 (18)	24 (28)	Around A4	
sRAW+	L	-	14.5 + 6.4	82	12 (12)	14 (16)	-
	M1		14.5 + 5.2	90	12 (12)	14 (16)	
	M2		14.5 + 3.9	97	12 (12)	18 (18)	
	S		14.5 + 2.2	100	18 (20)	20 (24)	

* The number of possible shots (battery life) and continuous shooting speed are based on Canon's testing standards and a 2 GB CF card.
 * Under Maximum burst, the number in parentheses is the maximum burst with a UDMA-compatible 2 GB CF card used in Canon's tests.
 * JPEG quality 8, ISO 100, the Standard Picture Style and initial Custom Function settings.
 * The actual file size of one image, number of possible shots (battery life), and maximum burst during continuous shooting vary depending on the subject, memory card brand, ISO speed, Picture Style, Custom Function settings, etc.

The EOS-1Ds Mark III is compatible with UDMA (Ultra Direct Memory Access), a new CF card specification (CompactFlash Specifications Revision 4.0) enabling high-speed writing to the CF card. With a UDMA CF card, the high-speed data transfer is about twice as fast as the EOS-1D Mark III (about 3 times as fast as the EOS-1Ds Mark II). Although the EOS-1Ds Mark III has twice as many pixels as the EOS-1D Mark III, the writing speed per file is about the same as the EOS-1D Mark III, which is quite amazing.

The camera is compatible with SD memory cards including SDHC (SD High-Capacity) cards. The writing speed with SD cards is the same as that of the EOS-1D Mark III.

Viewfinder

Large, bright viewfinders are an inherent advantage of full-frame sensor DSLR cameras. The viewfinder of the EOS-1Ds Mark III incorporates a totally redesigned pentaprism and refined eyepiece optics to make the viewfinder performance of the EOS-1Ds Mark III the best in its class. Remarkably, the viewfinder provides the highest magnification and widest coverage in the history of EOS-1 series cameras, including film models, approximately 0.76x and 35°. This is a substantial improvement over the EOS-1Ds Mark II. The new finder also corrects the distortion in EOS-1Ds series cameras to make the large viewfinder look more natural. The 100% viewfinder coverage, approximately 20mm eye-point, -3 to +1 dpt dioptic adjustment range, and eyepiece shutter are the same as the EOS-1D Mark III's. It is now an even greater pleasure to look through the finder and the point of focus is much easier to find and follow.

Viewfinder Coverage Comparison

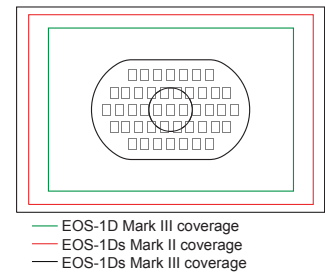

Major Viewfinder Specifications

Item	1Ds Mark III	1Ds Mark II	5D	1D Mark III
Coverage [Approx. %]	100	100	96	100
Magnification [Approx. X] (Viewing angle [°])	0.76 (35.0)	0.70 (31.9)	0.71 (32)	0.76 (28.3)
Eye point	Approx. 20 mm			
Dioptic adjustment	-3 - +1 dpt			

As with the EOS-1Ds Mark II, glass with a high refractive index is used for high performance. To match the higher viewfinder magnification (wider viewfinder coverage), the pentaprism and SI prism have been made larger, necessitating a change in the top exterior cover of the camera's body.



The lens type and glass selection have been changed to make the eyepiece lens larger. By having 4-lens elements in 4 groups for the eyepiece optics, flare is suppressed.

Viewfinder Optics 1

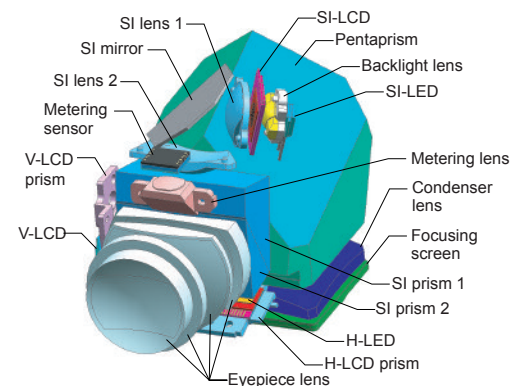

As with the EOS-1Ds Mark II, the superimposition display consists of the lead-in component, integrating the dichroic prisms (SI prism 1 and 2) with the pentaprism and the illumination (SI-LED), liquid-crystal (SI-LCD), and the eyepiece lens. Compared with the EOS-1D Mark III's dichroic mirror system, the dichroic prism system can have a more compact light path in the lead-in component. This contributes to a higher viewfinder magnification.

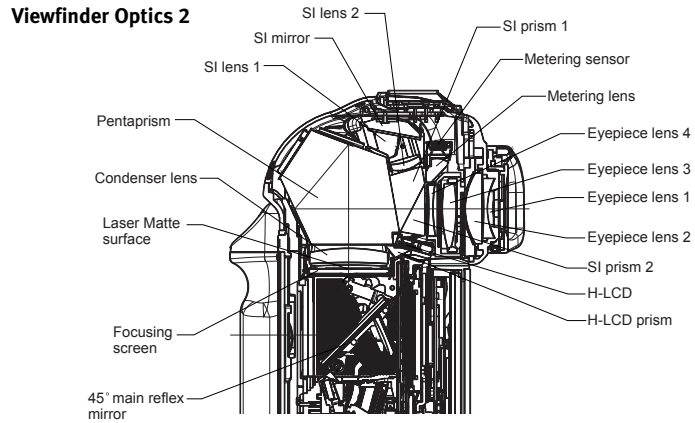

The exceptional legibility of the viewfinder means it is now a practical option to include a great quantity of information in the finder display.

Viewfinder Information

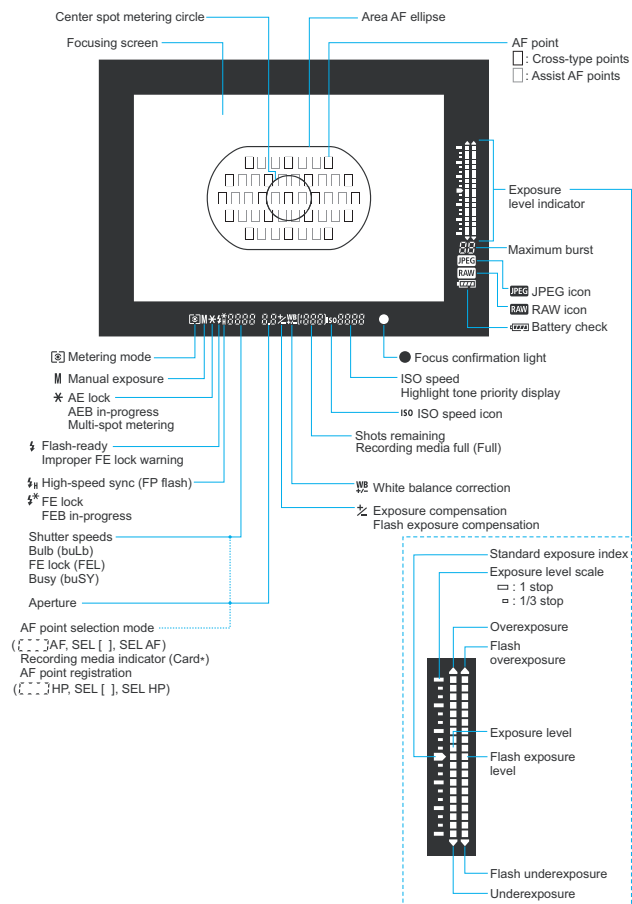

New UDMA Compatibility

UDMA (Ultra Direct Memory Access) is a new specification for CF cards (Compact Flash Specification Revision 4.0) to enable high-speed writing to the card. With a UDMA-compliant CF card, the data transfer speed is twice as fast as with the EOS-1D Mark III, and the writing speed is on par with the EOS-1D Mark III (and about 3 times as fast as the EOS-1Ds Mark II) even though the pixel count is twice as large.

ISO Speed

With a higher number of pixels in the same sensor dimensions, the pixel size is necessarily smaller than those of the EOS-1Ds Mark II. Nevertheless, the ISO speed range is the same as that of the EOS-1Ds Mark II with ISO 100 to 1600 and ISO extensions of 50 (L) and 3200 (H).* The ISO speed Safety Shift is enabled via C.Fn I-8-2. The ISO speed control value differs from that of the EOS-1D Mark III. Note that the maximum burst during continuous shooting will decrease if ISO speed safety shift, noise reduction for high ISO speeds (C.Fn II -2-1), or a high ISO speed is set. (The maximum burst during continuous shooting is displayed in the viewfinder.)

*Standard output sensitivity. Recommended exposure index.

EOS Integrated Cleaning System

The EOS-1Ds Mark III uses the EOS Integrated Cleaning System, a complete dust reduction system for reducing dust adhering to the imaging sensor, removing dust, and making dust spots less noticeable. The Self Cleaning Sensor Unit is a newly designed, dedicated unit optimized for the full-frame CMOS sensor. As with the EOS-1D Mark III, this unit has two thin piezoelectric elements that apply ultrasonic vibration to shake dust off the infrared absorption glass which is the outermost layer in front of the low-pass filter. The removed dust then sticks to the absorbent material lining the perimeter of the infrared absorption glass. Mechanisms such as the shutter and the mirror are manufactured in ways that reduce the generation of dust. The LPF uses grounding and a conduction process to discharge static electricity, minimizing dust adherence. And, to prevent the dust from entering the internal parts, the unit's outer periphery is sealed. The specifications of the unit's operating condition, forced termination condition, and Dust Delete Data acquisition and application are the same as with the EOS-1D Mark III.

Self Cleaning Sensor Unit Construction Diagram

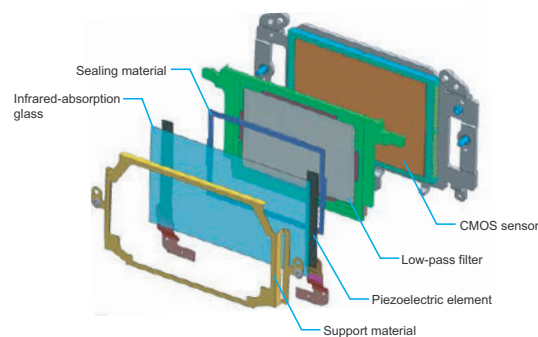

Absorbent Material

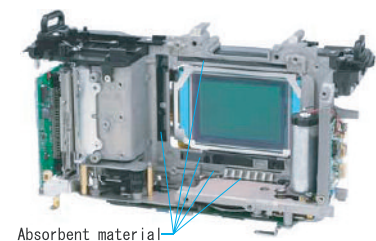

Drive

As with the EOS-1D Mark III, 6 drive modes (single shooting, high-speed continuous, low-speed continuous, 10-sec. self-timer, 2-sec. self-timer, and silent single shooting) are provided. The noise level of the single shooting and silent single shooting modes is the same as with the EOS-1D Mark III.

Having the same drive mechanism as the EOS-1D Mark III, the EOS-1Ds Mark III's maximum continuous shooting speed is 5 fps in both the One-Shot AF and AI SERVO AF modes. This rate is achieved with 8-channel reading, DDR-SDRAM (twice the capacity of the EOS-1Ds Mark II's), and Dual "DIGIC III" Image Processors. Continuous shooting speed can also be adjusted with C.Fn III-16 [Continuous shooting speed] as follows: High-speed continuous within 2 to 5 fps, and low-speed continuous within 1 to 4 fps.

Metering and Exposure Control

The metering optics have the metering lens and 63-zone metering sensor positioned at the rear of the pentaprism. The 19 AF points in the Area AF optimally match the metering sensor's zones.

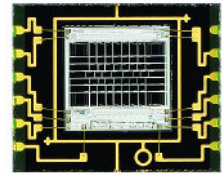

Metering Sensor

The same 4 metering modes as in the EOS-1D Mark III are provided. Partial metering covers about 8.5% of the viewfinder area at the center, and spot metering about 2.4% at the center.

Because the metering area within the viewfinder is smaller than that of the EOS-1D Mark III, the algorithm has been optimized for the EOS-1Ds Mark III. However, the basic algorithm is the same as the EOS-1D Mark III's.

Metering Zones

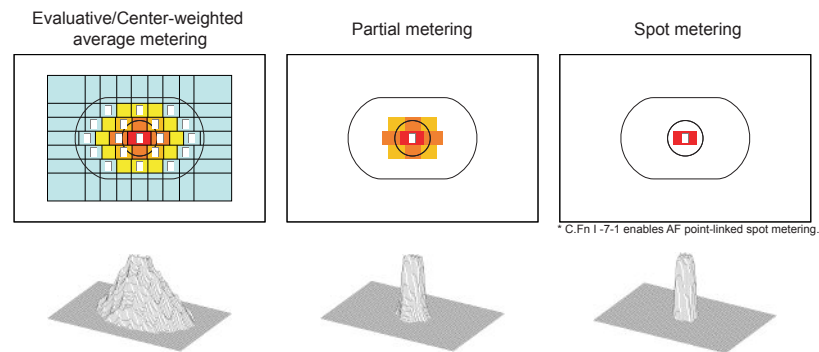

ISO bracketing is not provided in either the EOS-1Ds Mark III or the EOS-1D Mark III.

With the Ec-A, Ec-B, Ec-I, and Ec-L interchangeable focusing screens, only spot metering outside the center and center-weighted average metering is possible. Since the prism centers of these focusing screens are plainly transparent, an error will occur with evaluative metering, partial, and center spot metering.

Custom Functions

The Custom Functions are the same as the EOS-1D Mark III's. The Custom Function names, settings, numbers and so forth are the same. The only exceptions are C.Fn I-3 [Set ISO speed range], C.Fn I-8-2 [Safety shift: Enable (ISO speed)], C.Fn I-15-1 [Flash sync. speed in Av mode: 1/250 sec.], and C.Fn III-16 [Continuous shooting speed]. Either the setting values or control values have been changed to suit the EOS-1Ds Mark III's specifications.

Direct Printing and PictBridge

Besides adding PictBridge, as with the EOS-1D Mark III, two features shared with the EOS 40D have also been incorporated that work with all Canon printers that support PictBridge. First, printing effects such as B/W, Vivid, Brightness, and Adjust levels are now reflected in the image displayed. Only the Face Brightener and Red-eye Correction are not reflected in the displayed image. Second, with the trimming screen displayed, turning the Quick Control Dial will tilt the displayed image up to ± 10 degrees in 0.5-degree increments.

All PictBridge-compatible Canon printers can now be used to set the Brightness, Adjust levels, Contrast, Color saturation, Color tone, and Color balance (except for Face Brightener and Red-eye Correction). Previously, this was possible only with the Canon PIXMA Pro9500 and Pro9000. Compatibility with Face Brightener and Red-eye Correction depends on the printer type.

When printing sRAW images through direct printing, the JPEG image will be used to make the print. The pixel count for the JPEG image and the sRAW image is the same. For RAW+JPEG images, the RAW image will be used to make the print. For sRAW+JPEG images, the JPEG image will be used to make the print. Note that if the JPEG image size is small, print size should be limited appropriately. Finally, a RAW image taken by another camera cannot be printed via direct printing. Since the RAW image processing method and imaging processor differ among cameras, compatibility cannot be ensured.

External Flash Control

The [Zoom] and [Wireless set.] flash functions have been added. These settings make it easier to view, summarize and set complicated wireless set-ups. As on the EOS 40D, one can now set all wireless flash settings with the camera's LCD monitor instead of the master Speedlite when the 580EX II is used. All external flash function settings and external flash Custom Functions settings other than these are the same as the EOS-1D Mark III's.

Printing Effects Reflected in the Displayed Image

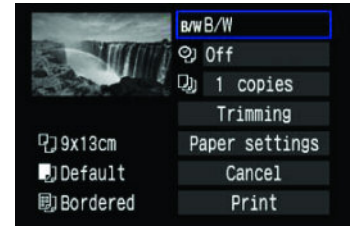

Tilt Correction



Zoom

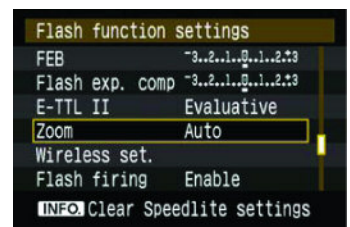

Wireless Settings

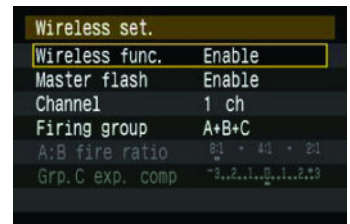

Flash Function Settings (with 580EX II)

Flash function settings

With E-TTL II

Item	Description
Flash mode	E-TTL II / Manual flash / MULTI flash
Shutter sync.	1st curtain 2nd curtain Hi-speed
FEb	-3..2..1..0..1..2..+3
Flash exp. Comp	-3..2..1..0..1..2..+3
E-TTL II	Evaluative Average
Zoom	Auto/24/28/35/50/70/80/105 [mm]
Wireless set.	Wireless func.: Enable/Disable
	Master flash: Enable/Disable
	Channel: 1/2/3/4ch
	Firing group: A+B+C/A/B/A:B C A:B fire ratio: 8:1, 4:1, 2:1, 1:1, 1:2, 1:4, 1:8 Grp.C exp. comp: -3..2..1..0..1..2..+3
Flash firing	Enable Disable
INFO. Clear Speedlite settings	

With Manual Flash

Item	Description
Flash mode	E-TTL II / Manual flash / MULTI flash
Flash output	1/128..1/64..1/32..1/16..1/8..1/4..1/2..1/1
Shutter sync.	1st curtain 2nd curtain Hi-speed
Zoom	Auto/24/28/35/50/70/80/105 [mm]
Wireless set.	Wireless func.: Enable/Disable
	Master flash: Enable/Disable
	Channel: 1/2/3/4ch
	Firing group: A+B+C/A/B/A:B C Group A output: 1/128.....1/1 Group B output: 1/128.....1/1 Group C output: 1/128.....1/1
Flash firing	Enable Disable
INFO. Clear Speedlite settings	

With Multi Flash

Item	Description
Flash mode Manual flash / MULTI flash / TTL
Flash output	1/128..1/64..1/32..1/16..1/8..1/4..1/2
Frequency	1 - 199 Hz
Flash count	--, 1 - 100 times
Zoom	Auto/24/28/35/50/70/80/105 [mm]
Wireless set.	Wireless func.: Enable/Disable
	Master flash: Enable/Disable
	Channel: 1/2/3/4ch
	Firing group: A+B+C/A/B/A:B C Group A output: 1/128.....1/1 Group B output: 1/128.....1/1 Group C output: 1/128.....1/1
Flash firing	Enable Disable
INFO. Clear Speedlite settings	

* The flash output applies to 1/4 to 1/128 in whole-stop increments.
(The display shows 1/2 to 1/128 in 1/3-stop increments.)

With TTL (With Flash C.Fn settings C.Fn-5-1)

Item	Description
Flash mode	MULTI flash / TTL / AutoExtFlash
Flash output	1/4..1/2..1/1
Shutter sync.	1st curtain 2nd curtain High-speed
Zoom	Auto/24/28/35/50/70/80/105 [mm]
Flash firing	Enable Disable
INFO. Clear Speedlite settings	

* Flash output will be fixed at 1/1. (Displayed from 1/4 to 1/1.)

With external Speedlite set to autoflash

(With Flash C.Fn settings C.Fn-5-2)

Item	Description
Flash mode	TTL / AutoExtFlash / Man.ExtFlash
FEb	-3..2..1..0..1..2..+3
Flash exp. Comp	-3..2..1..0..1..2..+3
Zoom	Auto/24/28/35/50/70/80/105 [mm]
Flash firing	Enable Disable
INFO. Clear Speedlite settings	

With external Speedlite set to M

(With Flash C.Fn settings C.Fn-5-3)

Item	Description
Flash mode	TTL / AutoExtFlash / Man.ExtFlash
Zoom	Auto/24/28/35/50/70/80/105 [mm]
Flash firing	Enable Disable
INFO. Clear Speedlite settings	

Design and Construction

Due to the large pentaprism, the top cover is a newly designed, dedicated cover having a bulge on the hot shoe area. It is 0.12 in./3mm taller than the EOS-1D Mark III and 2mm taller than the EOS-1Ds Mark II. As with the EOS-1Ds Mark II, the "Ds" and "Mark III" nameplates are gold-plated.

Magnesium Alloy Exterior



Exterior Covers and Internal Construction

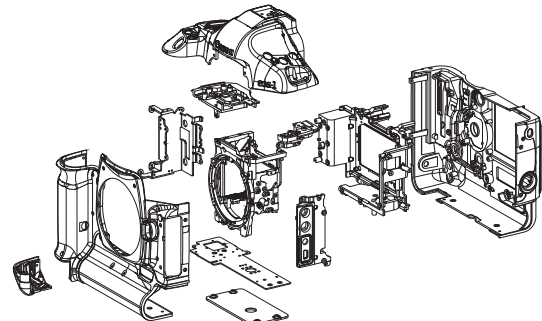

The dimensions (W x H x D) of the EOS-1Ds Mark III are: 156 x 159.6 x 79.9mm/6.1 x 6.3 x 3.1 in. It is 3mm taller than the EOS-1D Mark III. The body-only weight is approximately 42.7 oz./ 1,210g, approximately 1.9 oz./55g heavier than the EOS-1D Mark III but 0.18 oz./5g less than a body-only EOS-1Ds Mark II. The difference in this case becomes more pronounced when the respective batteries are added in: 48.9 oz./1,385g for the EOS-1Ds Mark II vs. 54.9 oz./ 1,555g for the Mark II, a difference of approximately 6 oz./170g.

Water- and dust-resistant construction is the same as the tight and thorough sealing of the EOS-1D Mark III.

Except for the 35mm full-frame CMOS sensor, large glass pentaprism, and full-frame Self Cleaning Sensor Unit, the internal components (including the shutter and the shutter-release mechanism) are the same as those of the EOS-1D Mark III.

The basic electronic components are the same as those of the EOS-1D Mark III. However, certain boards have been optimized for the 35mm full-frame CMOS sensor. For example, due to the larger circuit, the Self Cleaning Sensor Unit board has been split into two boards.

All parts comply with the RoHS (Restriction of the Use of Certain Hazardous Substances in Electrical and Electronic Equipment) Directive.

Location of Major Water-resistant Measures



Parts Count

Item	1Ds Mk III	1Ds Mk II
Optics	35	30
Mechanical parts	674	628
Electrical parts	1557	1479
Circuit boards	41	43
Lead wires	162	22
Total (Official)	2323	2202
Screws and washers	349	311
Total	2672	2513

- * The shutter unit is counted as 1 part.
- * The DC/DC converter is counted as 1 part.
- * The E-ring is counted as a washer.
- * The official total excludes the screws and washers.

Cross Section at Center

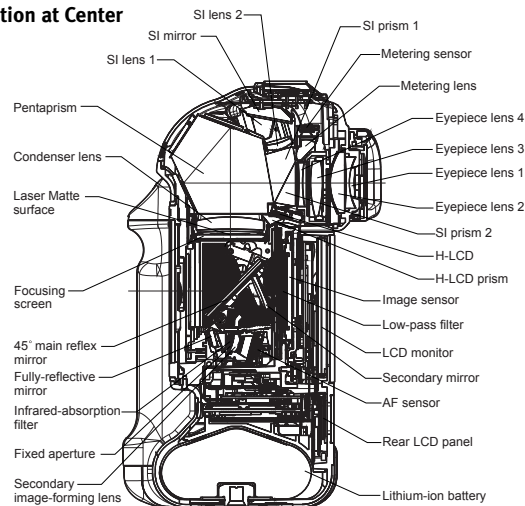

If there is a small noise when the camera is shaken, it is the sound of the ball bearings in the camera orientation detection unit.

Power Source and Shooting Performance

Except for the number of possible shots (battery life), all the specifications are the same as those of the EOS-1D Mark III. Because the EOS-1Ds Mark III has the full-frame CMOS sensor and full-frame Self Cleaning Sensor Unit, battery life is shorter than that of the EOS-1D Mark III by about 20%. At 73°F/23°C, this is approximately 1,800 shots maximum, and at 32°F /0°C, approximately 1,400 shots maximum.

As with the EOS-1D Mark III, an automatic battery check is performed when the main switch is turned on. Battery level is indicated by one of six levels on the LCD panel. Current battery, remaining capacity (indicated in 6 levels with icon and in 1% increments), current shutter count with the battery since the battery recharge, and recharge performance can be checked. Power turns off after the set time (1, 2, 4, 8, 15, or 30 min.) of non-operation elapses. Even when set to [Off], the LCD monitor will turn off 30 min. after idle operation, but camera power does not turn off.

Live View Function

The professional Live View Function included in the EOS-1D Mark III and EOS 40D is part of the EOS-1Ds Mark III as well. In brief, Live View Function works either on the camera's LCD monitor or by remote (with EOS Utility). It makes it possible to place the camera in positions for which it would be difficult or impossible to look in the finder to check composition and verify exposure, depth of field or focus. It has grid display and aspect ratio display features.

During Live View Function with the EOS-1Ds Mark III, an icon is now displayed to indicate exposure simulation (when one presses the depth-of-field preview button or set C.Fn IV-16-1). Other than this, the Live View Function is the same as that of the EOS-1D Mark III. The EOS 40D enables AF and silent shooting during Live View Function, but these features are not provided by the EOS-1Ds Mark III because of a difference in shutter design.

During Live View Function, approximately 300 shots can be taken at 73°F/23°C or 230 shots at 32°F/0°C. In the EOS Utility Ver.2.2 disk to be bundled with the EOS-1Ds Mark III, a test-shooting feature and preview feature will be newly added to the Remote Live View Function.

In EOS Utility ver.2.1, users could adjust the white balance in Remote Live View Function using ambient light by looking at the real-time Live View Function image on the PC screen. They could then store the results on the camera with a single mouse click. However, users could not check the real-time Live View Function image for shots taken with the flash, so they had to check the finished shots, adjust the settings as needed and retake the shot. The new Test Shooting function offers users a simple procedure for adjusting white balance for flash photography, as follows:

Test Shooting Window

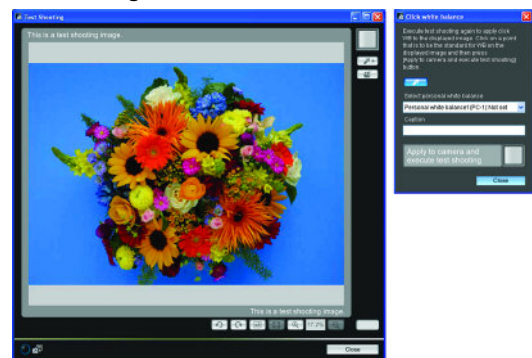

- 1) Take a test shot using the flash. The Test Shooting window automatically opens showing the photographed image.
- 2) Set Click White Balance for a suitable location in the displayed image.
- 3) Take the test shot again using the flash.
The results of step 2 are applied and stored in the camera and then applied to the test shooting results.

Check the resulting shot in the test window. The image in the Test Shooting window is updated each time one takes a test shot and is automatically deleted when the Test Shooting window is closed. However, one can save the image by clicking the Save button. One can also use this function for shots taken using ambient light.

Another new, Live View Function related feature is Quick Preview. Until now, image checking for remote shooting using EOS Utility has been achieved by transferring images to DPP (Digital Photo Professional) or ZoomBrowser EX/ImageBrowser, which launch automatically. As a result, there has always been a time lag of several seconds between shooting and image checking. The new Quick Preview function is Canon's response to user requests for a shortening of this time lag.

In EOS Utility ver.2.2, users can check the results of remote shooting immediately in a Quick Preview window that automatically appears after the shot is taken. The default window size is 600 x 428 pixels, but one can adjust the window to any size, including full-screen. Note that the Quick Preview window always shows the last shot one took. One can choose whether to show or hide the Quick Preview window by clicking the Show/Hide Quick Preview button in the Capture window. The Quick Preview function can be used by all cameras that are compatible with EOS Utility ver.2.2, even if Live View Function is not involved.

Quick Preview Window



Shutter The shutter unit is the same as that of the EOS-1D Mark III, with a durability of 300,000 cycles. Because of the larger frame size, flash sync is 1/250 sec. rather than the 1/300 sec. of the EOS-1D Mark III with EOS Speedlites.



Shutter Unit

V. ACCESSORIES

New EF 14 mm f/2.8L II USM Lens

The EF 14mm f/2.8L II USM is an ultra-wide-angle lens that was developed as the successor to the EF 14mm f/2.8L USM. Since the EF 14mm f/2.8L USM was first released in 1991, it has been widely used as a high-performance ultra-wide-angle lens by both professional and high-end amateur photographers. At the same time, there has been increasingly strong demand from the market for a lens with improved image quality, particularly in peripheral areas. To meet these demands, the EF 14mm f/2.8L II USM features completely redesigned optics that offer not only significant improvements in image quality, but features such as dust- and moisture-proofing, resulting in a high-performance lens that exceeds even the stringent requirements of professional users.

EF 14mm f/2.8L II USM



Optical Construction

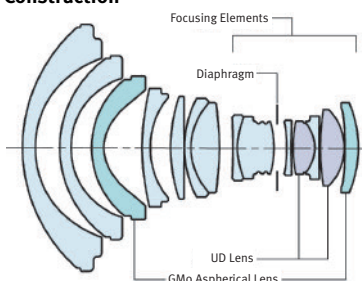

Compared to the now-discontinued EF 14mm f/2.8L USM, the dimensions of the new lens are: maximum diameter, 88.5mm (+5mm), overall length 111.6mm (+8.6mm), and weight 645g (+85g). The minimum focusing distance is 0.2m and the maximum magnification is 0.15x.

Extenders EF 1.4x II and EF 2x II, and Extension Tubes EF 12 II and EF 25 II cannot be used with the lens. Also, the lens has no filter threads, so it cannot be used with the screw-in 250D, 500D, and 500 Close-up Lenses, as well as with Gelatin Filter Holders III and IV. The lens comes with a new, secure, spring mechanism lens cap, Lens Cap 14.

Features:

- High-performance L-series lens capable of ultra-wide-angle shots with a diagonal angle of up to 114°
- Uses 2 high-precision GMo aspherical lens elements (G3 is 40mm diameter aspherical lens element) to provide excellent correction for curvature of field, distortion and other aberrations, giving superb image quality over the entire image, and particularly in peripheral areas, that far exceeds previous models

- Uses 2 UD lens elements to minimize lateral chromatic aberration to which wide-angle lenses are prone, achieving superb image quality with excellent resolution and contrast with little or no color bleed around the outline of the subject
- Lens coatings and lens disposition optimized to minimize the ghosting and flare that frequently occur when the lens is used with a digital camera

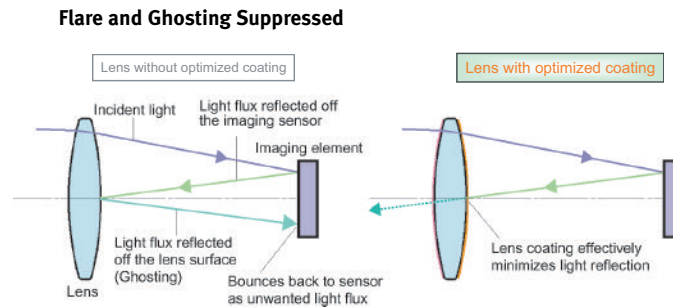

- Waterproof and dustproof construction used in the mount, focus mode switch and focusing ring to prevent dust and moisture from getting into the lens, making it suitable for taking pictures even in harsh conditions
- EMD has circular aperture that produces beautiful out-of-focus images (bokeh)
- Rear focusing system, ring USM, high-speed CPU and improved AF algorithms for fast and quiet autofocus
- Manual focusing enabled even during the AF mode (full-time mechanical manual focus)
- Focus mode switch has been given a shape that prevents it from being changed accidentally
- Equipped with constriction-type gelatin filter holder at the rear of the lens
- Uses a new type of specially designed lens cap (Lens Cap 14) that is both light and secure
- Optical system constructed using only glass which is lead-free

VI. SOFTWARE

EOS Digital Solution Disk Ver.16 will ship with the EOS-1Ds Mark III camera at no additional cost. Each component is modified to bring EOS-1Ds Mark III compatibility to such things as RAW and sRAW files, as well as metadata.

The new EOS Utility, ver.2.2, has 2 enhancements to Live View Function, a Test Shooting function and a Quick Preview function. Both are discussed in the Live View Function section of this paper.

DPP (Digital Photo Professional) is upgraded from version 3.1 to 3.2. The 2 main additions are the lens aberration correction function and the brightness warning display function.

Lens Aberration Correction Function

While lens optics are designed to achieve the best possible balance in minimizing different types of aberrations and defects, these do remain, even if only minimally, as in reality it is impossible to eliminate aberrations completely. The new “Lens Aberration Correction Function” provides correction by way of image processing to handle divergences from ideal imaging.

Aberration correction is achieved by re-processing the image, combining the following information with the photographed RAW image:

- 1) The optical data for the lens:
The DPP software includes data containing lens IDs and optical characteristics of each lens
- 2) Lens information for the lens used (lens ID):
Automatically recorded to the supplementary information for photographed RAW images
- 3) The focal length information when shots are taken:
Automatically recorded to the supplementary information for photographed RAW images
- 4) The distance information when shots are taken:
Automatically recorded to the supplementary information for photographed RAW images.

Note: some of the specifications for recording the supplementary RAW image information in 2), 3) and 4) vary depending on the EOS Digital camera used.

There are 4 factors that this function can correct:

- 1) Peripheral illumination:
Corrects peripheral light, which declines as one moves away from the center of the image, by increasing brightness at the image periphery so that brightness is uniform over the entire image

- 2) Distortion:
Corrects images where shape relationships are disrupted so that they appear as they should
- 3) Chromatic aberration:
Corrects color fringing that arises around the image periphery
- 4) Color blur:
Corrects the blue and red color blurring that can occur at the edges of very bright areas in images

This innovative technology ties together the lens information, camera lens system information and image design in a comprehensive way that could be achieved only by a truly comprehensive camera manufacturer.

At present, 29 EF lenses (lenses with built-in lens ID, focal length and distance information) are supported.

Lenses Compatible with Lens Aberration Correction Function

EF 14mm f/2.8L USM	EF 14mm f/2.8L II USM	EF 20mm f/2.8 USM
EF 24mm f/1.4L USM	EF 28mm f/1.8 USM	EF 35mm f/1.4L USM
EF 50mm f/1.2L USM	EF 50mm f/1.4 USM	EF 85mm f/1.2L USM
EF 85mm f/1.2L II USM	EF 100mm f/2.8 Macro USM	EF 16-35mm f/2.8L USM
EF 16-35mm f/2.8L II USM	EF 17-35mm f/2.8L	EF 17-40mm f/4L USM
EF 24-70mm f/2.8L USM	EF 24-105mm f/4L IS USM	EF 28-70mm f/2.8L
EF 28-135mm f/3.5-5.6 IS USM	EF 28-200mm f/3.5-5.6 USM	EF 28-300mm f/3.5-5.6L IS USM
EF-S 55-250mm f/4-5.6 IS	EF 100-400mm f/4.5-5.6L IS USM	EF-S 60mm f/2.8 Macro USM
EF-S 10-22mm f/3.5-4.5 USM	EF-S 17-55mm f/2.8 IS USM	EF-S 18-55mm f/3.5-5.6 USM
EF-S 18-55mm f/3.5-5.6 II USM	EF-S 18-55mm f/3.5-5.6 IS	

*Also usable for RAW images taken with extender mounted on supported lens.

Depending on the EOS Digital camera on which the lens is mounted, there are 2 modes of correction using DPP ver.3.2. In the latest models released in 2007 (EOS-1Ds Mark III, EOS 40D and EOS-1D Mark III), the lens ID and the focal length and distance information are recorded as supplementary information in photographed RAW images. As a result, these cameras meet all the requirements for aberration correction. To use aberration correction on these 3 models, simply check the boxes for the factors to be corrected in the [Lens aberration correction] window.

On the EOS-1D Mark II N, EOS-1Ds Mark II, EOS-1D Mark II, EOS-1Ds, EOS-1D, EOS 5D, EOS 30D and EOS Digital Rebel XTi/400D DIGITAL, the lens ID and focal length are recorded as supplementary information in photographed RAW images, but the distance information is not recorded. On these cameras, when one checks the boxes in the [Lens aberration correction] window for the factors to be corrected in photographed RAW images, aberration is corrected on the assumption that the distance is set to infinity.

To correct aberration in DPP, open the [Lens aberration correction] window (edit window or edit window tool palette [NR/Lens] tab > click the [Tune] button) and check the boxes for each of the 4 correction factors to be corrected. The image is then corrected and the

results are applied in real time to the image displayed in the [Lens aberration correction] window. One can then check the effects of distortion and peripheral illumination on the entire displayed image. One can also enlarge a section of the image to check for chromatic aberration or color blur by clicking in the section to be checked. That section then appears enlarged to 200% in the top right corner of the [Lens aberration correction] window, allowing one to check the effects in detail.

If one is not happy with the results of the corrections performed by DPP, one can use the sliders for the different correction factors or the shooting distance to make additional adjustments. Also, one can correct red chromatic aberration with the [R] slider of the [Chromatic aberration] or blue chromatic aberration with the [B] slider.

[NR/Lens] Tab in the Tool Palette



(Note that correcting peripheral illumination may result in noise appearing around the image periphery. One may be able to alleviate this noise by using the DPP noise reduction functions (luminance noise or chrominance noise reduction). In some images, using distortion correction may cause areas around the image periphery to be deleted. Also occasionally, color blur correction may have no discernible effect. Finally, color blur correction may also reduce color saturation in some images.)

Lens Aberration Correction Window

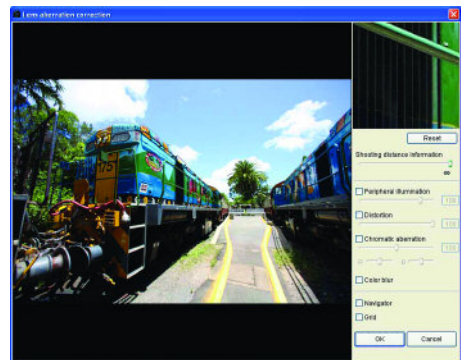

After completing the corrections, click the [OK] button to close the [Lens aberration correction] window. At that point, the corrections are applied to the image in the edit window and the corrections (ON or OFF) also appear in the tool palette.

Warning Display Settings in the Preferences Window



Brightness Warning Display Function

The brightness warning display function has also been added. It is useful in preventing excessive adjustment and in checking white flare or shadowing in images. One can use the [Preferences] window to specify separate settings for highlights and shadows in the warning display range settings. One can use the [View] menu, highlights that exceed the specified range are displayed in red and shadows that exceed the range are displayed in blue in the image in the Edit or Edit Image window.

Edit Window (with Warnings Displayed)

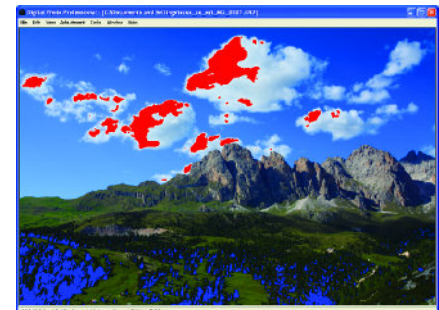

Additional Changes in DPP

Another new function that has been developed links DPP with the new “Easy-PhotoPrint EX” printing software for inkjet printers. This allows the transfer of RAW images selected in DPP directly to Easy-PhotoPrint EX so that RAW images can be printed simply and at high quality. The specifications and procedures for using the new software are the same as the previous “Easy-PhotoPrint” software.

A [View images at high speed (moiré reduction off)] option has been added to the [High quality] display mode. This will prove useful for those who want slightly faster image display when false color reduction is not needed, because they do not use false color reduction when viewing images in the Edit or Edit Image window.

The [Preferences] window has been amended to include a function for reducing the “block noise” and “mosquito noise” that particular affects JPEG images when RAW images are converted and saved in JPEG format. This makes it possible to improve the image quality particularly when high compression rates are used.

Preferences Window



DPP features:

- RAW image viewing/processing/editing software aimed primarily at amateur and professional users who mostly shoot RAW images
- High-speed processing of RAW images
- Support for RAW images from almost all EOS Digital camera models
- Viewing and editing of JPEG and TIFF images
- Links with Canon’s EOS software
- Window displays tailored to professional workflows
- Extensive range of image editing functions
- Real time display of image adjustments and comparison displays of edits
- Faithful, high-quality printing using links with Canon inkjet printers
- 3 printing style specification functions
- RAW image conversion and saving
- Batch processing of large numbers of RAW images

In versions up to DPP ver.3.1, thumbnail images that had been dragged into a different sequence in the main window reverted to the original display sequence when DPP was shut down. In ver.3.2, this has been improved so that the user’s thumbnail sequence is retained. With the addition of a [Retain sort order] checkbox in the [Preferences] window, DPP has been improved so that the current thumbnail sequence is retained when DPP is shut down. By clearing the [Retain sort order] checkbox, users who prefer the ver.3.1 specifications can revert to the previous system (in which the original sequence is restored when DPP shuts down).

Preferences Window

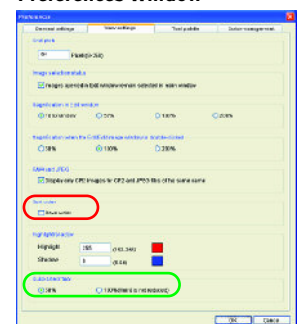

The Quick Check tool function has been improved with the addition of an [Information] button that displays the Shooting Information window; the control buttons have been rearranged to match more closely the way they are actually used. Also, whereas the only enlargement ratio available in the enlarged display was 50% in ver.3.1, the specifications have now been improved so that either 50% or 100% can be selected in the [Preferences] window.

Quick Check Window

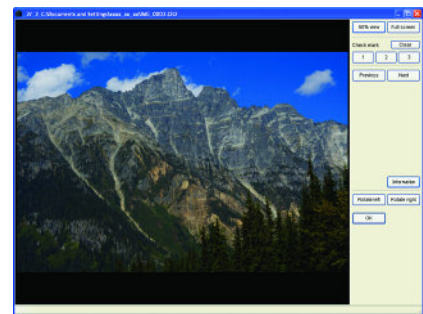

Picture Style Editor

Picture Style Editor Ver.1.1 is also included on Digital Solution Disk Ver.16. In brief, Picture Style Editor is software that allows users to create their own Picture Style files by selecting and loading a sample RAW image and then adjusting the image characteristics based on one of the existing Picture Style settings (Standard, Portrait, Landscape, Neutral or Faithful, but not Monochrome). The created Picture Style file can then be registered in the camera using EOS Utility, or used in the DPP or RAW Image Task applications.

There is only one change in Picture Style Editor from ver.1.0: the range of sample images available for adjustment has been expanded to include RAW images shot on all EOS Digital cameras (EOS D30 to EOS-1Ds Mark III. This includes EOS D6000 and D2000 RAW images that were converted using .CR2 Converter to RAW images with the “.CR2” extension.) There are no functional changes.

Note that there are some cameras that are not supported by and cannot be used with Windows Vista: the EOS-1Ds, EOS-1D, EOS 10D, EOS Digital Rebel/300D DIGITAL, EOS D60 and the EOS D30. Also, while the following cameras are compatible with Windows Vista for 32-bit systems, they are not compatible with Vista for 64-bit systems: the EOS-1D Mark II N, EOS-1Ds Mark II, EOS-1D Mark II, EOS 5D, EOS 20D and the EOS Digital Rebel XT/350D DIGITAL.

VII. SPECIFICATIONS

Type of Camera	<p>Type: Digital AF/AE SLR</p> <p>Recording Media: CF Card Type I and II, SD/SDHC Memory Card (1 slot each), and/or External media (USB v.2.0 hard drive, via optional Canon Wireless File Transmitter WFT-E2A), compatible with UDMA-compliant CF cards, and SDHC SD cards</p> <p>Image Format: 1.42 x 0.94 in./36.0 x 24.0mm (full-frame sensor)</p> <p>Compatible Lenses: Canon EF, TS-E, and MP-E lenses (except EF-S lenses)</p> <p>Lens Mount: Canon EF mount</p> <p>Lens Focal Length Conversion Factor: 1.0x</p>
Image Sensor	<p>Type: Full-frame, high-sensitivity, high-resolution, single-plate, CMOS sensor</p> <p>Effective Pixels: Approx. 21.10 megapixels</p> <p>Total Pixels: Approx. 21.90 megapixels</p> <p>Aspect Ratio: 3:2 (Horizontal : Vertical)</p> <p>Color Filter System: RGB primary color filters</p> <p>Low-pass Filter: Fixed position in front of the CMOS sensor</p> <p>EOS Integrated Cleaning System: (1) Self Cleaning Sensor Unit, (2) Dust Delete Data, (3) Manual Sensor Cleaning</p>
Recording System	<p>Recording Format: DCF 2.0 (Exif 2.21): JPEG, RAW and RAW+JPEG simultaneous recording possible. Multiple options for recording images on two memory cards, and onto compatible external USB hard drives (via optional Wireless File Transmitter WFT-E2A)</p> <p>Image Compression: JPEG, JPEG+RAW, RAW (Canon CR2)</p> <p>File Size: (1) JPEG/Large: Approx. 6.4MB (5,616 x 3,744); (2) JPEG/Medium 1: Approx. 5.2MB (4,992 x 3,328); (3) JPEG/Medium 2: Approx. 3.9MB (4,080 x 2,720); (4) JPEG/Small: Approx. 2.2MB (2,784 x 1,856); (5) RAW: Approx. 25.0MB (5,616 x 3,744); (6) sRAW: Approx. 14.5MB (2,784 x 1,856)</p> <p>Folders: Can be manually created by user, and freely selected for subsequent images</p> <p>File Numbering: (1) Continuous numbering (2) Auto reset (3) Manual reset (the image numbering is reset to 0001, a new folder is created automatically)</p> <p>Color Space: Selectable between sRGB and Adobe RGB</p> <p>Picture Style: Six preset Picture Style settings plus three user-defined custom Picture Style settings with individual adjustments for Sharpness, Contrast, Saturation, Color tone; Filter effect, Toning effect for black & white images</p> <p>Interface: USB 2.0 Hi-Speed, mini-B port. NTSC/PAL for video output</p>

White Balance **Settings:** Auto, Daylight, Shade, Cloudy, Tungsten Light, White Fluorescent Light, Flash, five Custom WB settings (1–5), user-set Color Temperature (2,500~10,000K), five Personal White Balance PC-1 to PC-5

Auto White Balance: Auto white balance, taken from imaging sensor

White Balance Correction: White balance bracketing: Three consecutive images, Up to +/- 3 levels in 1-step increments; White balance shift: blue/amber bias and/or magenta/green bias +/- 9 levels; manually set by user

Viewfinder **Type:** Eye-level SLR with fixed pentaprism

Coverage: Approx. 100% horizontally and vertically

Magnification: 0.76x (-1 dpt with 50mm lens at infinity)

Eyepoint: Approx. 20mm

Dioptic Adjustment Correction: 3.0 to +1.0 diopter

Mirror: Quick-return half mirror (Transmission: reflection ratio of 37:63)

Viewfinder Information: AF (AF points, focus confirmation light, point selection mode, registration), Exposure (metering mode, spot metering area, shutter speed, aperture, manual exposure, AE lock, ISO speed, exposure level, exposure warning), Flash (flash ready, high-speed sync, FE lock, flash exposure level), Image (JPEG recording, RAW recording, shots remaining, maximum burst, white balance correction, memory card information), Battery check

Depth-of-Field Preview: Enabled with depth-of-field preview button; possible in Live View Function

Eyepiece Shutter: Built-in

Autofocus **Type:** TTL-AREA-SIR AF-dedicated CMOS sensor

AF points: 45-point (19 high-precision cross-type AF points plus 26 Assist AF points)

AF Working Range: EV -1 ~18 (ISO 100 at 73°F/23°C)

Focusing Modes: Autofocus (One-Shot AF, Predictive AI Servo AF), Manual Focus (MF)

AF Point Selection: Automatic selection; Manual selection: 19 AF points, or only inner 9 AF points (C.Fn III-9-1), or outer 9 AF points (C.Fn III-9-2)

Selected AF Point Display: Superimposed in viewfinder and on LCD panel

AF-assist Beam: None. Emitted by EX-series Speedlite or optional ST-E2 Speedlite Transmitter

Exposure Control **Metering Modes:** 63-zone TTL full aperture metering; (1) Evaluative metering (linked to all AF points); (2) Partial metering (approx. 8.5% of viewfinder); (3) Spot metering (approx. 2.4% of viewfinder): Center spot metering, AF point-linked spot metering (C.Fn. I-7-1), Multi-spot metering (max. 8 spot metering entries); (4) Center-weighted average metering

Metering Range: EV 0–20 (ISO 100 at 73°F/23°C with EF 50mm f/1.4 USM lens, ISO 100)

Exposure Control Systems: Program AE (shiftable), Shutter speed-priority AE, Aperture-priority AE, E-TTL II program AE (Evaluative flash metering, Averaged flash metering), Manual, Bulb

ISO Speed Range: Equivalent to ISO 100–1600* (in 1/3-stop or whole stop increments), ISO speed can be expanded to ISO 50 and 3200 (via C.Fn I-3)

* Standard output sensitivity. Recommended exposure index.

Exposure Compensation: Exposure Compensation (user-set): up to +/-3 stops in 1/3- or 1/2 stop increments; Auto Bracketing (AEB): 3 shots, up to +/- 3 stops, in 1/3 or 1/2 stop increments, in all exposure modes. Sequence can be changed via C.Fn I-5

AE Lock: Auto: Applied in One-Shot AF mode with evaluative metering when focus is achieved; Manual (user-set): By AE lock button in all metering modes

Shutter Type: Vertical-travel, mechanical, focal-plane shutter with all speeds electronically controlled

Shutter Speeds: 1/8000 to 30 sec. (1/3-, 1/2- or 1-stop increments), X-sync at 1/250 sec. (with EOS dedicated external Speedlites; 1/250 maximum with other shoe-mount flashes, and 1/60th–1/250th with studio strobes*)

* maximum sync speed with studio strobes will depend upon flash characteristics and connection method; testing is encouraged to verify fastest possible sync speed with specific studio flash equipment.

Shutter Release: Soft-touch electromagnetic release

Self-Timer: 10 sec. delay, 2 sec. delay

Remote Control: Canon N3 type terminal

External Speedlite EOS External Flash or Dedicated Speedlite: E-TTL II autoflash with all EX Series Speedlites

PC Terminal: Provided; accepts third-party flash units with sync line voltages up to 250V maximum

Drive System Drive Modes: Single, silent, high-speed continuous (approx. 5 fps), low-speed continuous (approx. 3 fps), 10- or 2-sec. self-timer

Continuous Shooting Speed: Approx. 5 fps (at a shutter speed of 1/500 sec. or faster in all recording modes)

Max. Burst During Continuous Shooting: JPEG: approx. 56 frames; RAW: approx. 12 frames RAW+JPEG: approx. 10 frames (Large/Fine)

LCD Monitor Type: TFT color, liquid-crystal monitor

Monitor Size: 3.0 in., diagonal

Pixels: Approx. 230,000 pixels

Coverage: Approx. 100%

Brightness Control: 7 levels provided

Playback **Image Display Format:** Single image, 4-image index, 9-image index, Jump, AF point, Magnified zoom (approx. 1.5x to 10x), Brightness or RGB Histogram, Auto rotate, Rotate; Live View Function: view image before shooting on LCD monitor; live histogram and live simulation of exposure level possible with C.Fn IV-16-1
Highlight Alert: In the single image display and (INFO) display, over-exposed highlight areas will blink

Image Protection and Erase **Protection:** Single image, all images in a folder, or all images in the memory card can be protected or cancel the image protection
Erase: Single image, all images in a folder, all images in the memory card or check-marked images can be erased or unprotected
Direct Printing from the Camera: Possible with compatible PictBridge-enabled printers
Compatible Printers: CP and SELPHY Compact Photo Printers, PIXMA Photo Printers and PictBridge compatible printers (via USB Interface Cable IFC-200U, included with camera kit)
Settings: Print quantity, style (image, paper size, paper type, printing effects, layout), trimming, tilt correction

Sound Recording **Recording Method:** Via built-in microphone at rear of camera body; activated by pressing recording button on camera. Sound file attached to image file on memory card
File Format: WAV
Recording Time: Max. 30 sec. per recording

Menus **Menu Categories:** (1) Shooting (2) Playback (3) Setup, (4) Custom Function/My Menu
LCD Monitor Languages: 18 (English, German, French, Dutch, Danish, Portuguese, Finnish, Italian, Norwegian, Swedish, Spanish, Greek, Russian, Polish, Simplified/Traditional Chinese, Korean, Japanese)

Power Source **Battery:** One dedicated lithium-ion battery pack LP-E4. AC power can be supplied via the AC Adapter Kit ACK-E4 (included)
Number of Possible Shots: At 73°F/23°C: Approx. 1,800 shots; At 32°F/0°C: Approx. 1,400 shots
The above figures apply when a fully-charged Battery Pack LP-E4 is used
Battery Check: Automatic, displayed in six levels. Precise readout of percentage remaining, shots taken since last charge, calibration recommended, and approx. remaining battery life are displayed with Battery Info menu setting.
Power Saving: Provided. Power turns off after 1, 2, 4, 8, 15, 30 min.
Back-up Battery: One CR2025 lithium battery

Dimensions and Weight **Dimensions (W) x (H) x (D):** 6.1 x 6.3 x 3.1 in./156 x 159.6 x 79.9mm
Weight (Body only): 42.5 oz./1,205g

Operating Conditions **Operating Temperature Range:** 32–113°F/0–45°C
Operating Humidity Range: 85% or less

- All the specifications above are based on Canon's Standard Test Method.
- The camera's specifications and physical appearance are subject to change without notice.
- TFT monitor images shown in the white paper are simulated.

VIII. COMPARISON CHART

**EOS-1Ds Mark III vs.
EOS-1Ds Mark II
Comparison Chart**

	EOS-1Ds Mark III	EOS-1Ds Mark II	Comments
Resolution & Sensor			
Recording pixels	21.1 million	16.7 million	<i>Highest-resolution AF digital SLR in world (as of August, 2007); unprecedented large file sizes</i>
Full resolution	5616 x 3744	4992 x 3328	
Photoshop file size	approx. 60MB	approx. 48MB	
Sensor type	CMOS (Canon-produced)		
Sensor size	Full-frame — 24 x 36mm		<i>Entirely new CMOS technology similar to EOS-1D Mark III</i>
Lens conversion factor	None (1x)		
ISO sensitivity range	(50) 100 – 1600 (3200)		
Performance			
Maximum fps rate	5.0 fps	4.0 fps	<i>Fast shooting speed; greater burst rate</i>
Maximum frames in a burst	56 (full-resolution JPEGs, level-8 fine) 12 (RAW; full-resolution)	32 (full-resolution JPEGs, fine) 11 (RAW; full-resolution)	
Shutter speed range	30 ~ 1/8000 sec.		<i>Mark III shutter: highest durability rating ever in an SLR</i>
Fastest flash sync speed	1/250		
Shutter durability	300,000 exposures	200,000 exposures	
Continuous mirror lock-up	Yes (mirror down with SET)	—	<i>Easy continuous mirror-up</i>
Image Quality			
Processor	Dual "DIGIC III"	DIGIC II	<i>Mark III: two highest-speed processor units</i>
Analog to Digital conversion	14-bit (16,384 tones/channel)	12-bit (4,096 tones/channel)	<i>Smoother changes in tones</i>
Highlight Tone Priority	Yes	—	<i>Superb control of bright areas</i>
Color, Contrast & Sharpness adjustments	Canon Picture Style	Parameters + Color Matrix	<i>Broader range of in-camera image control</i>
Integrated cleaning system	Yes	—	<i>Built-in dust removal system</i>
High-ISO noise reduction	Yes	—	<i>Further noise-reduction option</i>
Custom White Balance	5 settings possible	1 setting	<i>Far more flexibility</i>
White Balance Shift	Yes (9 steps to alter WB)	—	<i>Outstanding fine-tuning ability</i>
AF System			
Number of AF points	45 (19 are cross-type)	45 (7 are cross-type)	<i>Entirely new Mark III AF system</i>
User-selectable AF points	19	45	<i>Faster navigation to set AF points</i>
High-precision points off-center	Yes (all 19 user-select pts.)	—	<i>Outer AF points more efficient</i>
AF Microadjustment	Yes	—	<i>Fine-tune AF if needed</i>
Metering System			
Evaluative metering	63 zones	21 zones	<i>Finer segmentation; superior shot-to-shot consistency</i>
E-TTL II flash metering	63 zones	21 zones	
Computer Interface			
Direct-connection type	USB 2.0 Hi-Speed	IEEE 1394 ("Firewire")	<i>Same speed; more extensive computer compatibility with USB</i>
Direct printing	Yes (PictBridge, plus new Canon print effects features)	Yes (standard PictBridge)	
Recording Media			
Compatible cards	CF and/or SD cards (2 slots)	CF and/or SD cards (2 slots)	<i>SD slot – now SDHC compliant</i>
UDMA hi-speed compatible CF	Yes	—	<i>Much higher CF card speed</i>
Automatic switch from card 1 to 2	Yes	—	<i>Variety of user-settings available</i>
External hard drive compatible	Yes	—	<i>Another high-capacity option; requires optional WFT-E2A</i>
RAW + JPEG recording	Possible to record RAW on one card, JPEG on other	RAW + JPEG always on same card(s)	<i>Mark II N – easier organization of images before downloading</i>
User-set file name prefix	Yes (first four characters)	—	<i>Mark II N: can be set on menu</i>
Separate image type recording	Yes	—	<i>Any file type on one card; different type on other card</i>
LCD Monitor & Playback			
LCD monitor size	3.0 inches (diagonal) 230,000 pixels	2.0 inches (diagonal) 230,000 pixels	<i>Largest LCD monitor on market (as of August, 2007)</i>
Ultra-wide LCD view angle	Yes	—	<i>View up to 70° angle</i>
Live View shooting	Yes	—	<i>Excellent for studio or remote</i>
Live View to computer	Yes (via USB or Wireless)	—	<i>Live View can work remotely</i>

**EOS-1Ds Mark III vs.
EOS-1Ds Mark II
Comparison Chart
(cont.)**

	EOS-1Ds Mark III	EOS-1Ds Mark II	Comments
Wireless Transmitter			
Wireless transmitter unit	WFT-E2A (optional)	WFT-E1A (optional)	<i>Far smaller, more integrated wireless unit; more functions</i>
Transmission modes	FTP, PTP, HTTP	FTP only	<i>Remote camera control and viewing camera using web browser now possible</i>
USB host port	Yes	—	<i>1. External hard drive useable 2. GPS compatibility</i>
Set-up	Wizard-based	Conventional FTP	<i>Much easier set-up for Mark III</i>
Transmitter power supply	Uses camera battery	Separate BP-511	<i>No additional battery needed</i>
Other			
Camera control	Dials plus SET button	Hold button, turn dial	<i>Much easier camera operation</i>
Silent mode	Available on-camera	via Personal Function only	<i>Easy access to quiet shooting</i>
Speedlite control from camera	Camera's menu controls 580EX II flash	—	<i>Quick flash control, using camera's menu</i>
Custom Functions	57 (all in-camera)	20, plus 27 Personal Functions	<i>No need to upload anything from computer; broadest EOS range of in-camera control</i>
Battery type	New Canon LP-E4 Lithium Ion	Canon NP-E3 (NiMH)	<i>Same lightweight battery pack as EOS-1D Mark III</i>
Battery life	Up to 1,800 shots (at 68°F)	Up to 1,200 shots (at 68°F)	
Precise battery read-out	Yes	—	<i>Battery info on camera menu</i>
Weight (including battery)	48.8 oz. (body only)	54.7 oz. (body only)	<i>Mark III: noticeably lighter</i>
Approx. price	\$7,999 (body only)	\$7,999 (body only)	<i>Prices at time of initial launch</i>

■ =significant new feature or competitive advantage

All referenced product names, and other marks, are trademarks of their respective owners.
Specifications and availability are subject to change without notice.
Pricing subject to change at any time. Actual prices are determined by individual dealers and may vary.

IX. CONCLUSION

When it was introduced, Canon, with complete justification, called the EOS-1Ds Mark II “The Absolute Pinnacle of DSLR Design and Performance.” Now the pinnacle has been raised. Technological advances have continued to come at a furious rate, even as the digital age of photography has matured, and it should surprise no one that Canon is able to build a better flagship than it did a few years ago. Nonetheless, there are many aspects of the EOS-1Ds Mark III that are astonishing. For example, the 16.7-megapixel, 4 fps EOS-1Ds Mark II it succeeds is still the leader in its class. On the same full-size sensor plate, Canon now has 21.1 megapixels that, although they are smaller than those of the EOS-1Ds Mark II, record a finer image with 14-bit depth and vastly greater control possibilities. At 5 fps, the EOS-1Ds Mark III fires off its enormous image files as fast as most 10 megapixel cameras can make 12-bit files. This is one camera that can excel in studios, sporting venues, and the farthest and most remote reaches of the earth. Its files can generate prints and magazine layouts equally remarkable for their great size and superlative quality. No other camera can make such a claim credibly.

Viewed in terms of its resolution alone, the EOS-1Ds Mark III seems to compete with the medium format digital backs that cost somewhere between more and much more. At this point, many even have less resolution than the EOS-1Ds Mark III. But their cumbersome handling and their very limited and expensive systems, especially in comparison with the Canon EOS System, mean that they are capable of functioning in just a very small portion of all the photographic situations in which the EOS-1Ds Mark III excels.

Consider, too, the question of continuity, a matter of considerable relevance when the purchase of an \$8,000-or-more camera is on the table. Where the EOS-1Ds Mark III is completely compatible with virtually all of the vast EOS System, and can be expected to remain compatible—and supported—for decades to come (note the current software support for the D6000 and D2000), today’s medium format digital backs often do not fit even recent products from the same manufacturer. Will a newly-purchased component be compatible with same-brand software and hardware in the not-too-distant future? Betting on, and investing in, the EOS-1Ds Mark III is a sure thing.

When Canon shows a diagram of its DSLR family, it has co-equals at the top of the range, the EOS-1D Mark III with a 1.3x sensor, 10.1 megapixels and a breathtaking 10 fps, matched with the EOS-1Ds Mark III, with its full-frame sensor, 21.1 amazing megapixels and a not-to-be-believed 5 fps for that file size. Both have Live View Function, the Self Cleaning Sensor Unit, the endless control and customization options, the high ISOs and low noise and the super-rugged construction. Both epitomize professional hardware. Choosing between them is really a matter of degree. Both have extraor-

dinary speed and image quality. For the photographer for whom the highest speed is an absolute must, the EOS-1D Mark III is the camera of choice. For photographers for whom the finest possible image quality in a complete package of professional excellence is the goal, there is the EOS-1Ds Mark III. There is nothing else.

Contents ©2007 by Canon U.S.A., Inc. All Rights Reserved. Canon, EOS, DIGIC, PIXMA and SELPHY are registered trademarks of Canon Inc. in the United States, and may also be registered trademarks or trademarks in other countries. All other products and brand names are registered trademarks, trademarks or service marks of their respective owners.

Excerpts from this material may be quoted in published product reviews and articles. For further information, please contact Canon U.S.A., Inc. Public Relations Dept., (516) 328-5000

Free Manuals Download Website

<http://myh66.com>

<http://usermanuals.us>

<http://www.somanuals.com>

<http://www.4manuals.cc>

<http://www.manual-lib.com>

<http://www.404manual.com>

<http://www.luxmanual.com>

<http://aubethermostatmanual.com>

Golf course search by state

<http://golfingnear.com>

Email search by domain

<http://emailbydomain.com>

Auto manuals search

<http://auto.somanuals.com>

TV manuals search

<http://tv.somanuals.com>