

# Installation, Start-Up and Service Instructions

## CONTENTS

	Page
<b>GENERAL</b> .....	1
<b>SAFETY CONSIDERATIONS</b> .....	2
<b>INSTALLATION</b> .....	2
<b>Step 1 — Check Equipment and Jobsite</b> .....	2
● <b>INSTALL OUTDOOR UNIT</b>	
<b>Step 2 — Select Locations for Indoor Fan Coils</b> .....	2
● <b>MAKE PIPING HOLE IN WALL IF NEEDED</b>	
● <b>INSTALL MOUNTING BRACKET</b>	
● <b>MOUNT FAN COIL UNITS</b>	
● <b>SHAPE INDOOR PIPING AND DRAIN HOSE</b>	
<b>Step 3 — Mount Multiplex Control Box</b> .....	5
<b>Step 4 — Connect Refrigerant Piping</b> .....	5
● <b>OUTDOOR UNIT</b>	
● <b>CONNECT LINES</b>	
● <b>COMPATIBLE FITTING REPAIR</b>	
● <b>CONNECT REFRIGERANT PIPING TO INDOOR FAN COILS</b>	
<b>Step 5 — Make Electrical Connections</b> .....	7
● <b>OUTDOOR UNIT</b>	
● <b>INSTALL BRANCH CIRCUIT DISCONNECT PER NEC</b>	
● <b>ROUTE LINE POWER LEADS</b>	
● <b>CONNECT GROUND LEAD AND POWER WIRING</b>	
● <b>CONNECT CONTROL POWER WIRING</b>	
● <b>INDOOR FAN COILS</b>	
<b>Step 6 — Evacuate System</b> .....	8
<b>START-UP</b> .....	11
<b>OPERATING INSTRUCTIONS</b> .....	12
<b>MAINTENANCE</b> .....	13

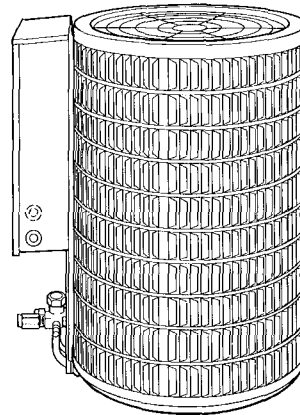

38EHX OUTDOOR CONDENSING UNIT (Cooling Only)

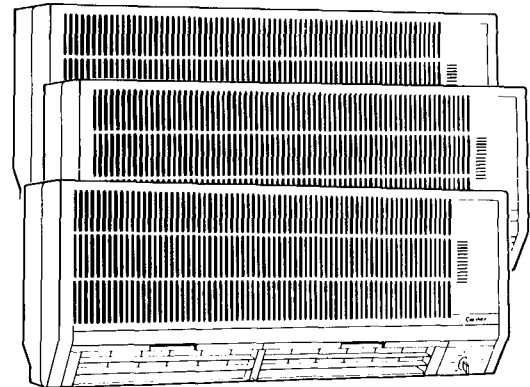

INDOOR FAN COILS (40QX)

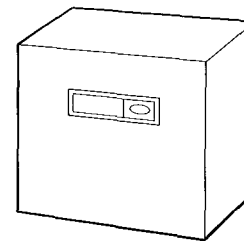

MULTIPLEX CONTROL BOX

### GENERAL (See Fig. 1, 3)

The 38EHX Multiplex air conditioning system requires 4 major components:

1. A 38EHX outdoor condensing unit.
2. Two or 3 wall-mounted indoor fan coil units (40QX) for distributing the air to a maximum of 3 independent zones.
3. A Multiplex control box, which connects outdoor coil with indoor fan coils and contains all necessary controls plus piping and electrical connections.
4. A Multiplex-only room thermostat for *each* indoor fan coil unit. Use thermostat HH07AT180.

**Fig. 1 — Multiplex System Components**

## SAFETY CONSIDERATIONS

Installing and servicing air conditioning equipment can be hazardous due to system pressure and electrical components. Only trained and qualified service personnel should install or service air conditioning equipment.

Untrained personnel can perform basic maintenance, such as cleaning and replacing filters. All other operations should be performed by trained service personnel. When working on air conditioning equipment, observe precautions in literature and on labels attached to unit.

Follow all safety codes. Wear safety glasses and work gloves. Use quenching cloth for brazing operations. Have fire extinguisher available. Consult local building codes and National Electrical Code (NEC) for special installation requirements. Read these instructions *thoroughly*.

### ▲ WARNING

Before installing or servicing unit, turn off main power to system. More than one disconnect switch may be needed. Electrical shock can cause personal injury.

## INSTALLATION

### Step 1 — Check Equipment and Jobsite —

Decide on proper locations for outdoor unit, indoor fan coils and Multiplex control box. Be sure to locate outdoor unit so that connection fittings are lined up to where Multiplex control box is to be located. Keep in mind that Multiplex control box must be conveniently located for connection to indoor fan coils. See Fig. 4, Typical Installation.

**INSTALL OUTDOOR UNIT** — Install outdoor unit on a solid, level mounting pad on roof, ground or balcony. It is recommended that unit be attached to pad using field-supplied tiedown bolts. Fasten unit to pad using holes provided in unit basepan. See Fig. 3.

**NOTE:** Installer may wish to wait until final installation steps before fastening tiedown bolts, to assure unit is in proper position.

When installing, allow sufficient space for airflow clearance, wiring, refrigerant piping and servicing. Maintain a minimum of 4 ft clearance from obstructions above and 18 in. around unit (12 in. on valve side). Maintain a distance of 24 in. between outdoor units if more than one is installed. If installed on ground or balcony, position so water or ice from roof or eaves cannot fall directly on unit.

### Step 2 — Select Locations for Indoor Fan Coils

— Be sure you have decided which rooms are to receive indoor fan coils (since piping and electrical wiring holes must be made in walls). Select walls that are: strong enough to support weight of units, not exposed to sunlight for long periods, accessible to convenient drainage of condensate away from patios, walls, etc., and free of blockage of air circulation around indoor fan coils.

Locate fan coils as high on wall as possible, allowing access to filters by owner. Leave at least 3-1/2 in. clearance from ceiling to top of fan coil to permit removal of access cover for maintenance.

1. Be sure indoor fan coils are easily accessible to refrigerant piping and electrical power line.

**IMPORTANT:** *Maximum* equivalent refrigerant line length from Multiplex box to any indoor fan coil should not exceed 65 feet. Maximum elevation differential between Multiplex box and any indoor fan coil should not exceed 50 feet. See Table 3 for additional charge needed.

2. Be sure indoor fan coil condensate tubing is accessible to proper drain.
3. Allow ample clearance for air filter to be removed by pulling straight downward. See Fig. 3, 18.
4. Avoid obstacles near inlet and discharge grilles that block airflow.
5. Be sure structural wall studs are sturdy enough to support mounting bracket and fan coil.
6. Decide whether to run refrigerant tubing and electrical wiring inside walls, ceiling, floors, etc., or to outside of building. Under all circumstances, AccuRater® devices, located at Multiplex control box and at fan coils must remain accessible for service.

### MAKE PIPING HOLE IN WALL IF NEEDED

1. Use template supplied in Installer's Literature packet shipped with Multiplex control box. Tack or tape template to wall in location desired for indoor fan coil.

**NOTE:** There are 2 sizes of fan coil: be sure to place correct sizes in rooms desired.

2. Cut a 2-1/2 in. diameter hole in wall as indicated on template. Hole may be cut only through interior wall for downward routing of tubing inside wall, or cut through to outside for routing tubing outdoors to control box.
3. If installer prefers piping hole in location off to side of indoor fan coil, mark off and make hole where it does not interfere with tubing joints.
4. After installing tubing, neatly close off hole to protect tubing and to seal against air leakage.
5. Piping hole must be made at downward angle to outside to ensure proper condensate drainage.

### INSTALL MOUNTING BRACKET (Fig. 2)

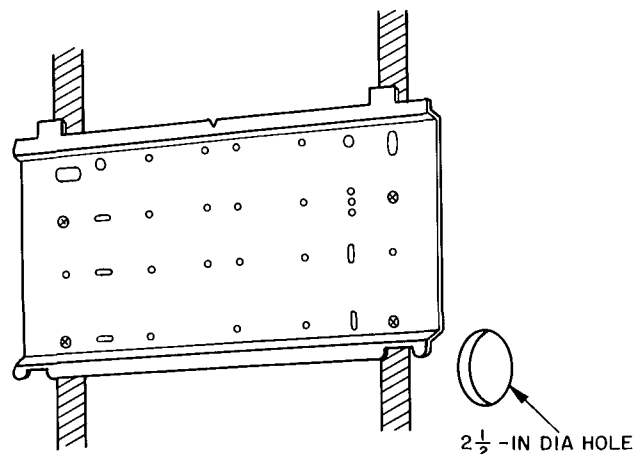
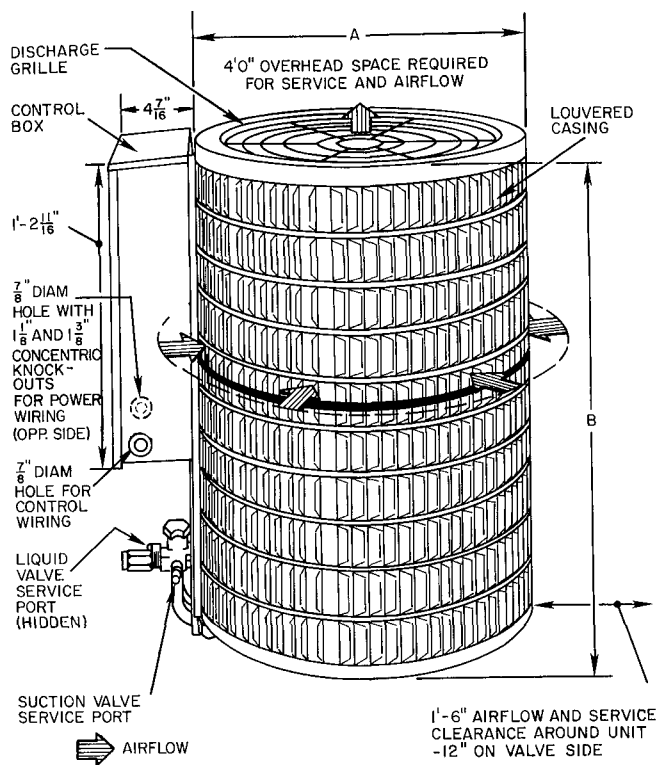
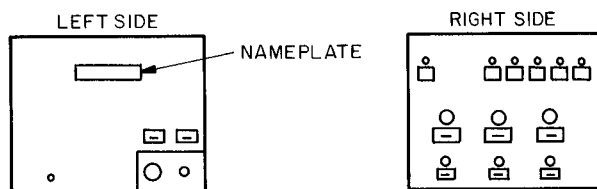
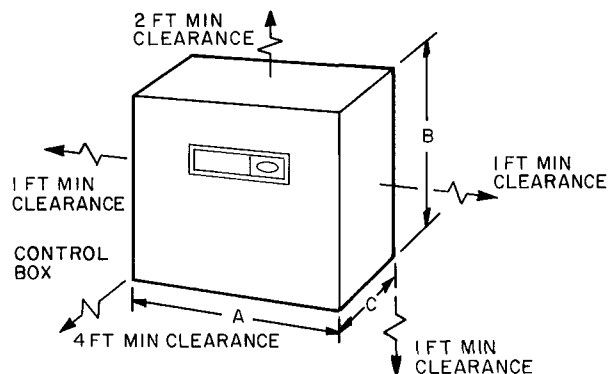
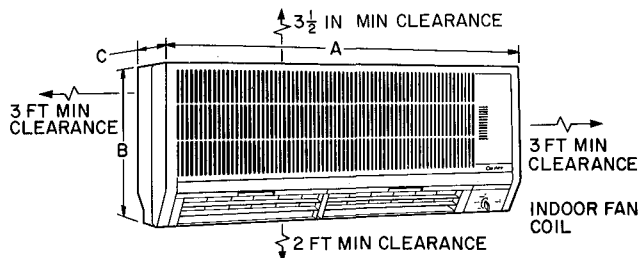

Fig. 2 — Mounting on Wall Studs in New Construction Application



38EHX CONDENSING UNIT



CONTROL BOX LABEL LOCATIONS

SIZE 018

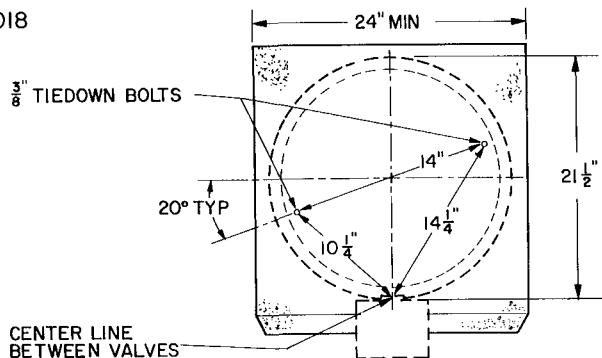

SIZE 030

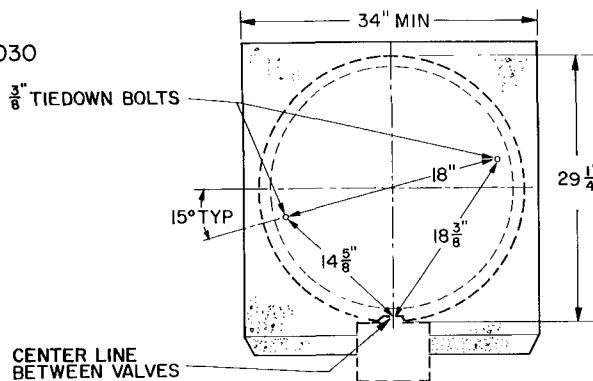

Certified dimension drawings available upon request

Fig. 3 — Dimensions, Connections and Mounting Pad (Refer to Tables 1 and 2.)

Table 1 — Physical Data, Outdoor Unit

MODEL 38EHX COND UNIT	018	030
OPERATING WEIGHT (lb)	121	161
REFRIGERANT Control	R-22 AccuRater® (installed in ID coil)	
CONDENSER FAN	Propeller Type, Direct Drive, 1 Speed Vertical	
Air Discharge	1850	3100
Air Quantity (cfm)	830	850
Motor Rpm (60 Hz)	1/10	1/8
Motor Hp		
CONDENSING COIL (fins/in.)	16	
Tube Diameter (in.)	1/2	
Rows	1	
Face Area (sq ft)	12.37	17.11
DIMENSIONS (ft-in.)		
Diameter	A	B
Height	1-9 1/2	2-7
CONNECTIONS (in. ODF)		
Suction	3/4 Compatible	
Liquid	3/8 Flare	
REFRIGERANT LINES (in. ODF)		
Suction	3/4	
Liquid	3/8	

Table 2 — Physical Data and Dimensions, Indoor Fan Coil

INDOOR FAN COIL MODEL 40QX	006	008	013
OPERATING WEIGHT (lb)	35.2		57.2
REFRIGERANT	R-22		
DIMENSIONS (in.)			
Width	A	31 1/8	36 1/8
Height	B	14 3/8	15
Depth	C	6 3/8	10
COIL			
Tube Diameter (in.)		3/8	3/8
Rows		2	3
Refrigerant Circuits		1	2
Face Area (sq ft)		1.7	2.2
CONNECTIONS (in. (OD))		Flare	
Suction		1/2	
Liquid		3/8	

MULTIPLEX CONTROL BOX 38QH900300

OPERATING WEIGHT (lb)	48	
DIMENSIONS (in.)		
Width	A	19
Height	B	19 1/16
Depth	C	12 1/8

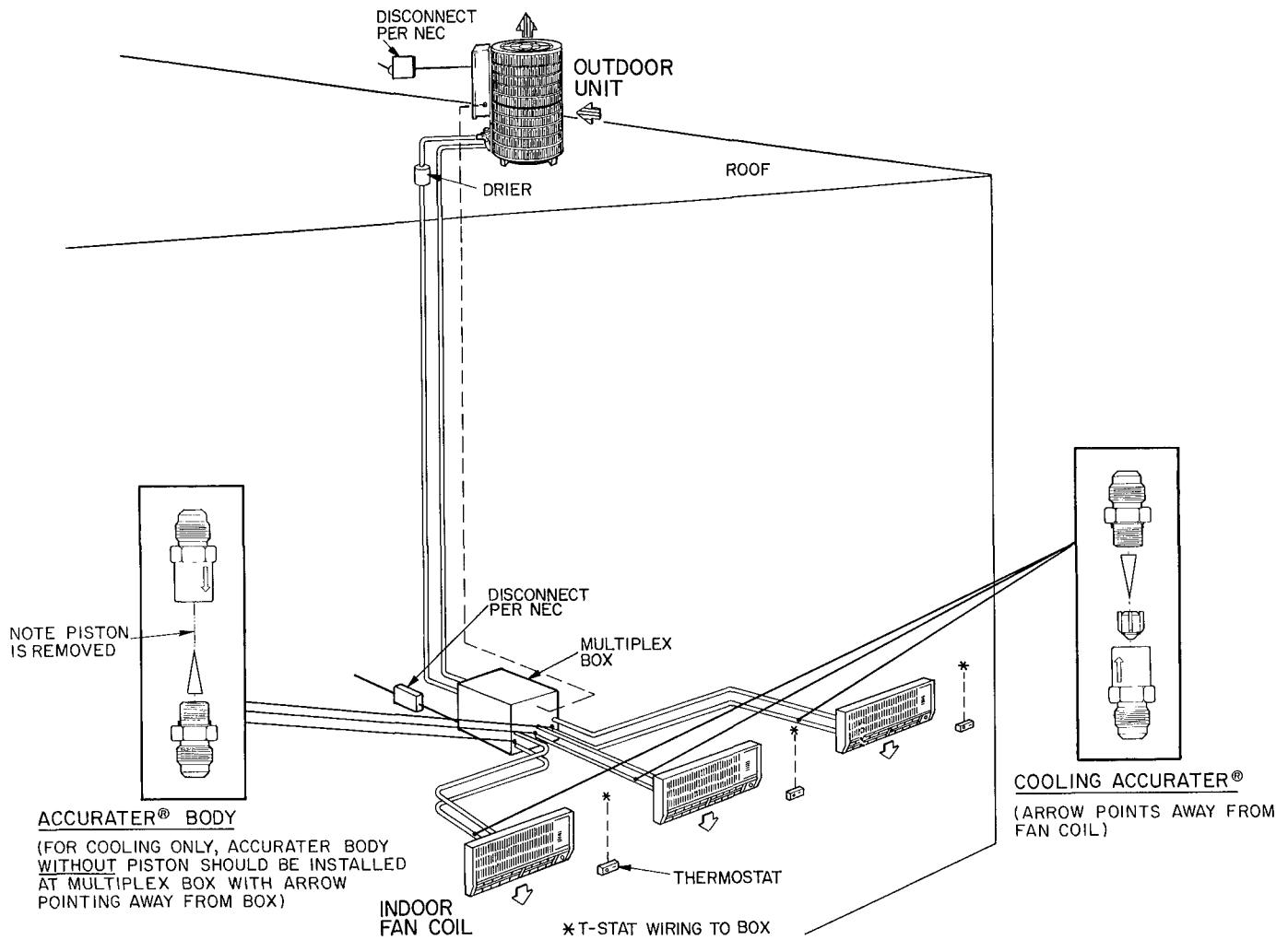

**Fig. 4 — Typical Installation**

1. Remove metal mounting bracket screwed to back of indoor fan coil unit.
2. Fasten mounting bracket *level* (use carpenter's level) on wall using 6 one-in. mounting screws or hollow-wall anchors, depending on wall construction. See paper template for locations of screw holes.
3. If mounting the bracket on a concrete wall using stud bolts, make stud bolt holes in locations shown on template.

#### MOUNT FAN COIL UNITS

1. 40QX013 units only:

Before hanging fan coil, mount decorative metal strip shipped separately on back of fan coil using 3 screws supplied.

After all electrical and piping connections are made, attach 2 end caps to metal strip.

#### **CAUTION**

Be sure hooks on mounting bracket are engaged firmly with indoor fan coil.

2. Electrical wiring, refrigerant piping and drain hose should be oriented as indoor fan coil is hung.
3. Make sure indoor unit is in position and level, and not leaning backward, forward, left or right.

#### SHAPE INDOOR PIPING AND DRAIN HOSE

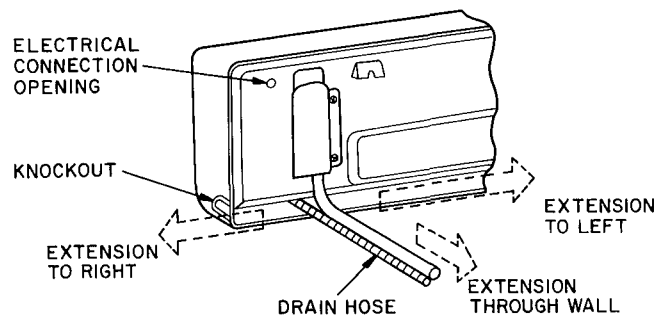

**Fig. 5 — Extending Drain Hose (Rear View of Fan Coil)**

NOTE: Piping can be led out at back to left or right, whichever is applicable. See Fig. 5.

1. Shape indoor fan coil stub pipes carefully with minimum curvature radius of 4 inches.
2. At final installation, include enough pitch on insulated drain pipe to ensure condensate drainage.
3. Be sure drain hose has no slack to form a trap. *Do not trap drain line* — drain is internally trapped.
4. If insulated drain hose (27-1/2 in.) extended from indoor fan coil is not long enough, use 1/2-in. PVC pipe and field-supplied screening at end to guard against dust, insects, etc.

5. Where extension drain pipe is routed inside conditioned space, be sure to wrap that section with field-supplied closed-cell foam insulation to avoid sweating.
6. There are 2 drain ports in drain pan. Use whichever is preferred, left or right. The insulated drain hose is factory installed to right-hand drain port. To switch to left connection, remove unit front panel. Follow procedure below:
  - a. Loosen hose clamp. Disconnect insulated drain hose from right drain port of drain pan.
  - b. Remove rubber plug from left drain port. Connect insulated drain hose onto left drain port. Reinstall hose clamp firmly.
  - c. Replace plug in right drain port. Be sure plug is securely installed.
7. Pour water into drain pan. Check to see if water drains properly.

**Step 3 — Mount Multiplex Control Box** — Control box contains connections for refrigerant tubing and electrical wiring. Box may be located outdoors adjacent to outdoor unit, or indoors in basement, closet, garage or other suitable area. Box should be positioned so that it can be conveniently inspected and serviced if necessary. Keep box out of reach of small children.

1. When box is not hanging on a wall, it should be installed on a field-supplied pad or stand. When mounting on a wall use 4 mounting holes provided on back side of box, and 4 field-supplied bolts (1/4-in. diameter) suitable for the intended mounting surface. Caulk and seal mounting holes and bolts to prevent any possible corrosion around mounting bolts.
2. Be sure to allow a minimum clearance of 12 in. from bottom of box. See Fig. 3.

**IMPORTANT:** *Maximum* equivalent refrigerant line length between control box and outdoor unit must not exceed 30 feet. Maximum elevation differential is 20 feet. Refer to Fig. 3 for service clearances. See Table 3 for additional charge needed.

3. **IMPORTANT:** *Maximum* equivalent refrigerant line length from Multiplex box to any indoor fan coil should not exceed 65 feet. Maximum elevation differential between box and any indoor fan coil should not exceed 50 feet. See Table 3 for additional charge needed.
4. There are 6 tubing connection stubs on right side of box, for 3 refrigerant liquid lines and 3 vapor lines to indoor fan coils.
5. Connect the liquid and vapor line from each indoor fan coil to proper tubing stubs in control box.

**▲ CAUTION**

Insulate all *liquid* and suction refrigerant lines to prevent sweating. Use field-supplied closed-cell foam insulation (minimum 3/8-in. wall thickness).

6. On left side of control box are 2 tubing stubs, one for liquid line and one for vapor line to outdoor section. Connect liquid and vapor lines from outdoor section to proper tubing stubs in control box. Use a filter drier installed in liquid line between outdoor unit and Multiplex control box. Condensate drain connection is also located on left side. If control box is mounted indoors, be sure to connect drain connection to a suitable drain.

**Step 4 — Connect Refrigerant Piping** — (Refer to Fig. 4.)

**Table 3 — Connections Between Outdoor Unit and Multiplex Control Box**

EQUIVALENT LENGTH (ft)	STANDARD CHARGE	ADDED CHARGE
VERTICAL LIFT (ft)	25	30
VERTICAL LIFT (ft)	10	20
PIPING DIAMETER (in.)	¾ suction, ¾ liquid	

**Connections Between Multiplex Control Box and Fan Coil**

EQUIVALENT LENGTH (ft)	STANDARD CHARGE	ADDED CHARGE
VERTICAL LIFT (ft)	50	65
VERTICAL LIFT (ft)	30	50
PIPING DIAMETER (in.)	½ suction, ¾ liquid	

NOTE: Maximum vertical lift allowable between condensing unit and fan coil unit is 35 ft with standard charge and 50 ft with added charge

**OUTDOOR UNIT** — Outdoor unit contains correct refrigerant charge to operate Multiplex system when connected by recommended length of field-supplied tubing (Table 3). For piping lengths longer than standard, add 1/2-oz. per ft of additional length. For shorter lengths, no change is required.

**▲ CAUTION**

**DO NOT BURY MORE THAN 3 FT OF REFRIGERANT TUBING IN GROUND.** If any section of tubing is buried, there must be a 6-in. vertical rise to the valve connections on the outdoor unit. If more than the recommended length is buried, refrigerant may migrate to the cooler buried section during extended periods of unit shutdown, causing refrigerant slugging and possibly compressor damage at start-up.

**CONNECT LINES** — Outdoor unit has flare connections on the liquid line and compatible fittings on the suction line (Fig. 3). Make liquid line connection first. Slide flare nut on liquid line, then flare and connect liquid line. Use a maximum torque of 15 ft-lb to tighten flare nut. On the suction line use the compatible fittings or adapt the unit to mechanical or sweat connections as described below.

**NOTE:** Compatible Fitting on outdoor section has aluminum plug located beneath compatible nut on suction valve. This plug keeps contaminants out of Compatible Fitting.

### ⚠ CAUTION

When removing compatible nut, be careful pressure buildup does not cause aluminum plug to blow and cause personal injury. After tubing is connected, discard plug.

#### Mechanical Connection

1. Remove nut on Compatible Fitting.
2. Remove plug and be sure O-ring is in the groove inside the Compatible Fitting.
3. Cut tubing to correct length, deburr and size as required. Slide nut onto tube.
4. Insert tube into Compatible Fitting until it bottoms. Tighten nut until it bottoms on shoulder of fitting or valve. Keep tube bottomed in Compatible Fitting while tightening nut.

### ⚠ CAUTION

If undersized, damaged or elliptically-shaped tubing is used when making Compatible Fitting, leaks may result.

**Sweat Connection** — Use refrigerant grade tubing.

1. Remove locking nut, rubber O-ring and Schrader core and cap from valve service port.
2. Cut tubing to correct length, deburr and size as required.
3. Insert tube in Compatible Fitting until it bottoms.  
**NOTE:** Wrap top and bottom of service valves in wet cloth to prevent damage by heat. Solder with low-temperature (430 F) silver alloy solder.
4. Replace Schrader core and cap.

**COMPATIBLE FITTING REPAIR** — If Compatible Fittings were originally used when unit was first installed and repairs are now required, proceed as follows:

**Mechanical Connection** — Frontseat unit service valves. Relieve refrigerant pressure from tubing. Back locknut off Compatible Fitting onto tube. Cut fitting between threads and O-ring. See Fig. 6. Remove tubing section remaining in threaded portion of fitting. Discard locknut.

Clean, flux and insert new tube end into remaining portion of Compatible Fitting. *Wrap valve in wet rag to prevent damaging factory-made joints.* Heat and apply low-temperature (430 F) solder.

**Sweat Connection** — Frontseat unit service valves. Relieve refrigerant pressure from tubing. Clean and flux around leak. Repair, using low-temperature (430 F) solder. Evacuate or purge evaporator coil and tubing system. Add refrigerant charge. See Start-Up.

**CONNECT REFRIGERANT PIPING TO INDOOR FAN COILS** (Table 3)

1. Use only refrigeration grade copper tubing. All tubing and insulation is field supplied.

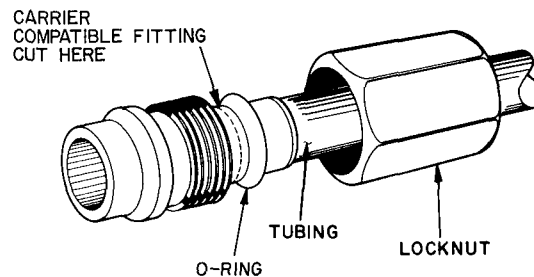

**Fig. 6 — Compatible Fitting**

2. Insulate all refrigerant lines to prevent sweating. Use any acceptable heat resistant closed-cell foam insulation (minimum 3/8-in. wall thickness).
3. To avoid kinking, measure and bend refrigerant tubing carefully, with a minimum bend radius of 4 inches.
4. Use tubing cutter to cut refrigerant tubing to size.
5. Place flare nut on tubing. Flare tubing end.
6. Assemble and install AccuRater®. See Fig. 7 and Table 4. AccuRater body is marked with an arrow that indicates the free flow direction. AccuRater piston must be installed with Teflon seal facing the opposite direction of the arrow. AccuRaters are installed in liquid line at each indoor fan coil with arrows pointing away from coil.
7. Line up tubing. Secure flare nuts using backup wrench.
8. Secure tubing neatly and safely.

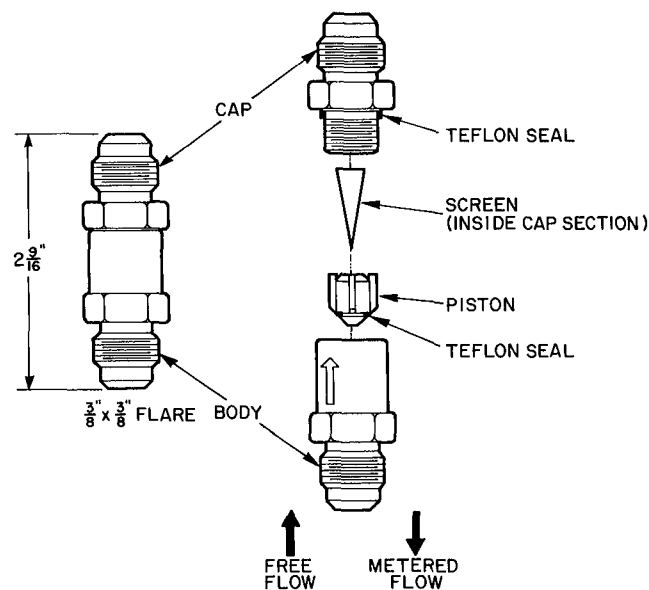

**Fig. 7 — AccuRater® Assembly**

**Table 4 — AccuRater Chart**

OUTDOOR UNIT 38	INDOOR UNIT 40QX	COOLING PISTON
EHX018	006,006,006	36,36,36
	006,006,008	36,36,37
	006,008,008	36,37,37
	008,008,008	37,37,37
	006,006,013	36,36,40
	006,008,013	36,37,40
	006,006	36,36
	006,008	36,37
	008,008	37,37
	006,013	36,40
	008,013	37,40

INDOOR UNIT — MODEL 40QX

V-PH-HZ	MOTOR FLA		
	006	008	013
208-230/1/60	15	18	28

Table 5 — Electrical Data

MULTIPLEX CONTROL BOX — MODEL 38QH900300

V-PH-HZ	OPER VOLTS		MINIMUM CIRCUIT AMPS	MAXIMUM OVERCURRENT PROTECTIVE DEVICE AMPS
	Max	Min		
208-230/1/60	254	187	15	15

OUTDOOR UNIT

MODEL 38EHX COND UNIT	V/PH (60 Hz)	OPER VOLTS*		COMPRESSOR		FAN FLA	MCA	MAX FUSE† OR HACR TYPE CIRCUIT BREAKER AMPS
		Max	Min	LRA	RLA			
018	208-230/1	254	187	43	7.8	0.7	10.5	15
030				88	18.7	0.9	24.2	40

FLA — Full Load Amps  
 HACR — Heating, Air Conditioning, Refrigeration  
 LRA — Locked Rotor Amps  
 MCA — Minimum Circuit Amps  
 RLA — Rated Load Amps

\*Permissible limits of the voltage range at which unit will operate satisfactorily  
 †Time-delay fuse

NOTE: Control circuit is 24v on all units and requires external power source

Step 5 — Make Electrical Connections

**OUTDOOR UNIT** — Be sure field wiring complies with local and national fire, safety and electrical codes, and voltage to system is within limits shown in Table 5. Contact local power company for correction of improper line voltage.

NOTE: Operation of unit on improper line voltage constitutes abuse and could affect Carrier warranty. Do not install unit in system where voltage may fluctuate above or below permissible limits.

See Table 5 for recommended fuse sizes. When making electric connections, provide clearance at unit for refrigerant piping connections.

**INSTALL BRANCH CIRCUIT DISCONNECT PER NEC** of adequate size to handle unit starting current. Locate disconnect within sight from and readily accessible from unit, per Section 440-14 of NEC (National Electrical Code).

**ROUTE LINE POWER LEADS** — Extend leads from disconnect through power wiring hole provided (see Fig. 3) and into unit splice area. Remove outdoor unit control box cover to gain access to unit wiring.

**CONNECT GROUND LEAD AND POWER WIRING** — Connect ground lead to ground connection in outdoor unit control box for safety. Then connect power wiring. See Fig. 8. Splice line power leads to yellow and black pigtails. Use wire nuts and tape at each connection. Connect unit wiring to copper power wiring only.

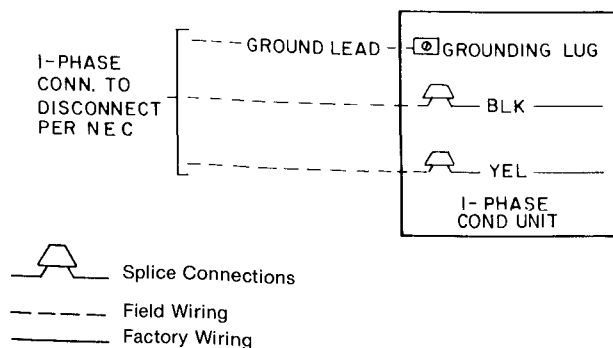

Fig. 8 — Line Power Connections, Outdoor Unit

CONNECT CONTROL POWER WIRING

- Route 24-v control wires through control wiring hole and connect to pigtails supplied with unit (Fig. 3). Splice control leads to brown and blue pigtails on all 38EHX units. See wiring labels, Fig. 11.

**WARNING**  
 To avoid personal injury, be sure system main power switch is turned off.

- Connect control wiring from outdoor unit terminal board to proper Multiplex control box terminals.

INDOOR FAN COILS

- Provide independent supply circuit for use of Multiplex control box, with independent fuse or circuit breaker. Provide disconnects as required by local or national code.

NOTE: Be sure electrical supply has identical voltage to that stated on indoor fan coil nameplate (see Table 5).

- Provide branch circuit to be connected from Multiplex control box to terminal block in each fan coil. It is recommended that a disconnect be provided at each remote fan coil, or use a separate 2-pole, 15-amp switch labeled "for service disconnect only." Thermostat control wiring is wired to Multiplex control box.

**CAUTION**  
 All wiring must be done in accordance with local codes and National Electrical Code (NEC).

- Use a right-angle connector to properly orient branch circuit wiring entering indoor fan coil.
- Remove front panel of indoor fan coil by removing screws along bottom of air discharge grille and pulling straight out and up. Save screws for reassembly. See Fig. 9.

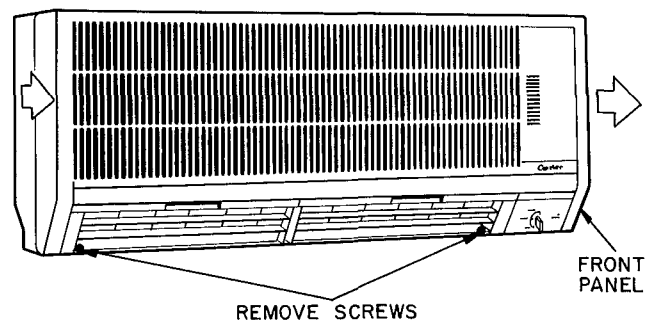

Fig. 9 — Removing Front Panel

5. Run branch circuit wiring (previously installed) into indoor fan coil through opening provided in back of fan coil control box. Connect wiring to proper terminals in indoor fan coil control box.
6. Connect wiring according to wiring label provided on indoor fan coil control box cover.
7. Insert wiring into terminals. Tighten screws firmly.
8. Secure wiring neatly and safely.
9. Install thermostat according to instructions packaged with thermostat. Route thermostat wiring through wall to Multiplex control box and connect to proper terminals.
10. Replace indoor fan coil front panel.

- c. Set all room thermostats to call for cooling. This will energize all solenoid valves and ensure entire system is evacuated.
2. Pressurize and leak check field-installed piping.
3. Evacuate field-installed piping using a vacuum pump.
4. Backseat (open) service valves on outdoor unit and allow refrigerant charge to enter system.
5. Outdoor unit is shipped with service valve stems front-seated (closed) and caps installed. Replace stem caps after valves are backseated (opened) to refrigerant flow. Replace caps finger tight and tighten an additional 1/6 turn with wrench. See sticker on valve cap.



### Step 6 — Evacuate System

1. To properly evacuate system:
  - a. Disconnect all power to outdoor unit. Leave service valves closed.
  - b. Energize Multiplex control box.

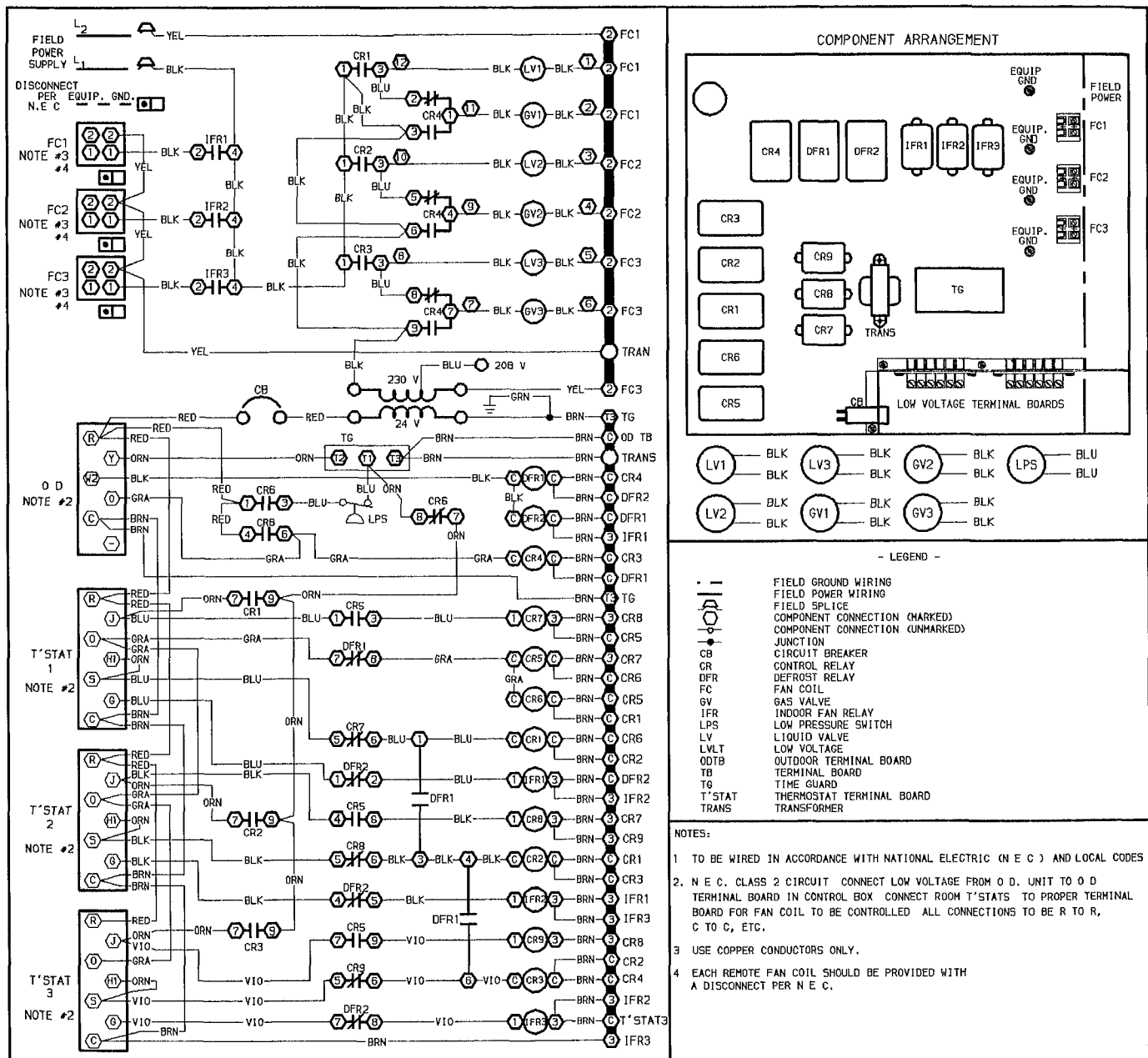
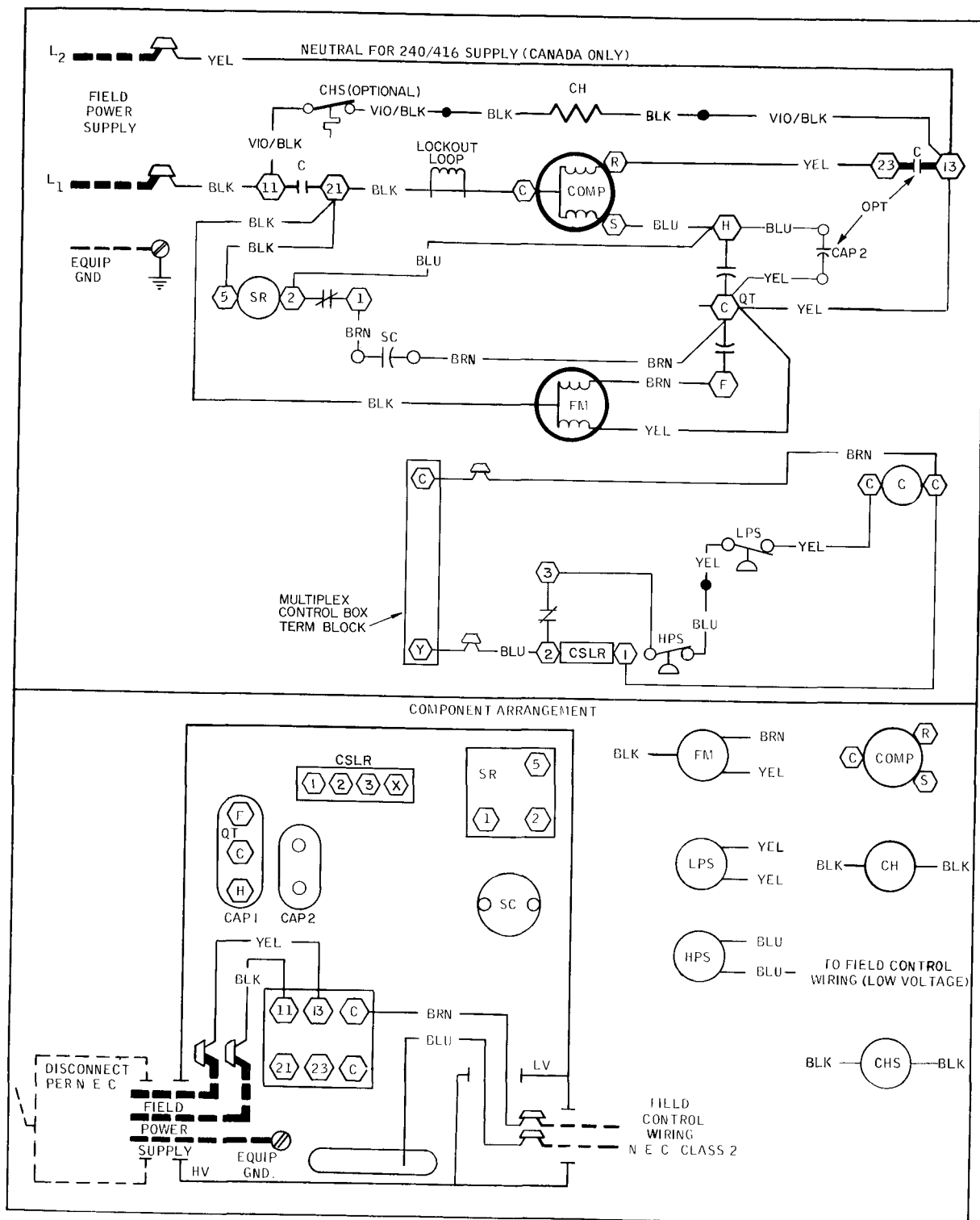

Fig. 10 — Multiplex Control Box Wiring Schematic





- C — Contactor
- Cap. — Capacitor
- CC — Cooling Compensator
- CH — Crankcase Heater
- CHS — Crankcase Heater Switch
- Comp — Compressor
- CSLR — Current Sensing Lockout Relay
- FM — Fan Motor
- HPS — High-Pressure Switch
- HV — High Voltage
- IFR — Indoor Fan Relay
- LLS — Liquid Line Solenoid
- LPS — Low-Pressure Switch
- LV — Low Voltage
- QT — Quad Terminal
- SC — Start Capacitor
- SR — Start Relay
- TC — Thermostat, Cooling

- Field Splice
- Component Connection (Marked)
- Component Connection (Unmarked)
- Factory Splice
- Field Control Wiring
- Field Power Wiring

- NOTES:
- 1 Compressor and fan motor furnished with inherent thermal protection
  - 2 To be used in accordance with National Electrical Code (NEC) and local codes
  - 3 Use copper conductors only

**Fig. 11 — Wiring Schematic, 38EHX Condensing Unit**

- LEGEND
- FIELD SPLICE
  - ⊗ TERMINAL MARKED
  - ⊙ TERMINAL UNMARKED
  - ⊕ JUNCTION AT 'STAT TO SUBBASE
  - FACTORY SPLICE
  - FIELD POWER WIRE
  - FACTORY WIRE
  - C CAPACITOR
  - CP COMPRESSOR
  - CR CONTROL RELAY
  - CS SELF-CLOSING LOGOUT RELAY
  - FN FAN MOTOR
  - GR GROUND CONNECTION
  - HP HIGH PRESSURE SWITCH
  - IR INDOOR FAN RELAY
  - LP LOW PRESSURE SWITCH
  - OL OVERLOAD
  - PL PLUS AEST.
  - SC START CAPACITOR
  - SR START RELAY
  - TR TERMINAL BOARD
  - TE THE GUARD
  - TL THERMISTOR
  - TRM TRANSFORMER

MODELS	
OUTDOOR SECTION	MULTI-PLEX CONTROL BOX
38EHX18300	36QH190300
38EHX030300	400X06300
	400X08300
	400X013300

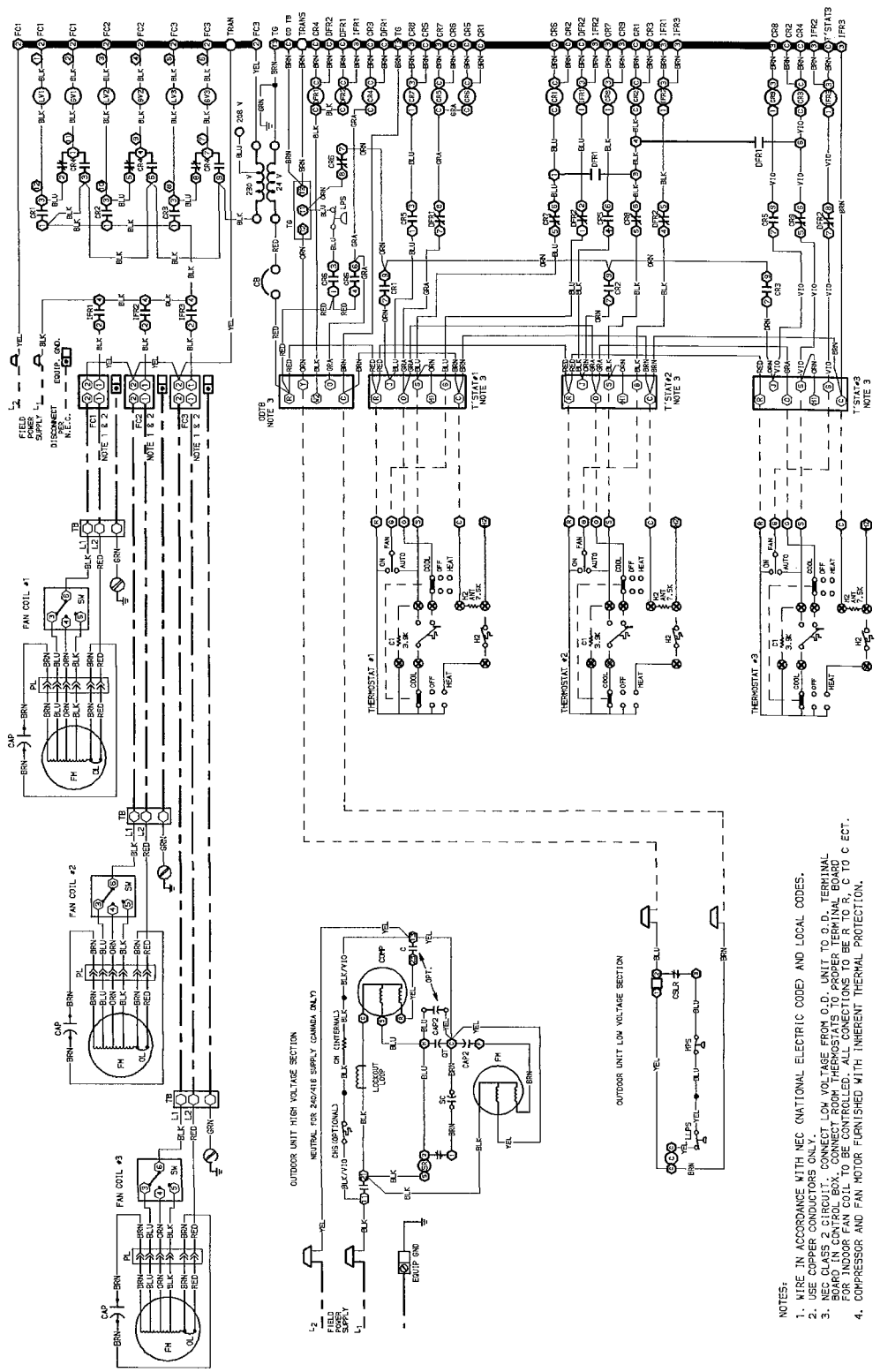

- NOTES:
1. WIRE IN ACCORDANCE WITH NEC (NATIONAL ELECTRIC CODE) AND LOCAL CODES.
  2. USE COPPER CONDUCTORS ONLY.
  3. NEC CLASS 2 CIRCUIT. CONNECT LOW VOLTAGE FROM O.D. UNIT TO O.D. TERMINAL BOARD IN CONTROL BOX. CONNECT ROOM THERMOSTATS TO PROPER TERMINAL BOARD FOR INDOOR FAN COIL TO BE CONTROLLED. ALL CONNECTIONS TO BE R TO R, C TO C ECT.
  4. COMPRESSOR AND FAN MOTOR FURNISHED WITH INHERENT THERMAL PROTECTION.

Fig. 12 — System Wiring Diagram

**OPERATIONAL CHECK CHARTS**  
38EHX COOLING ONLY

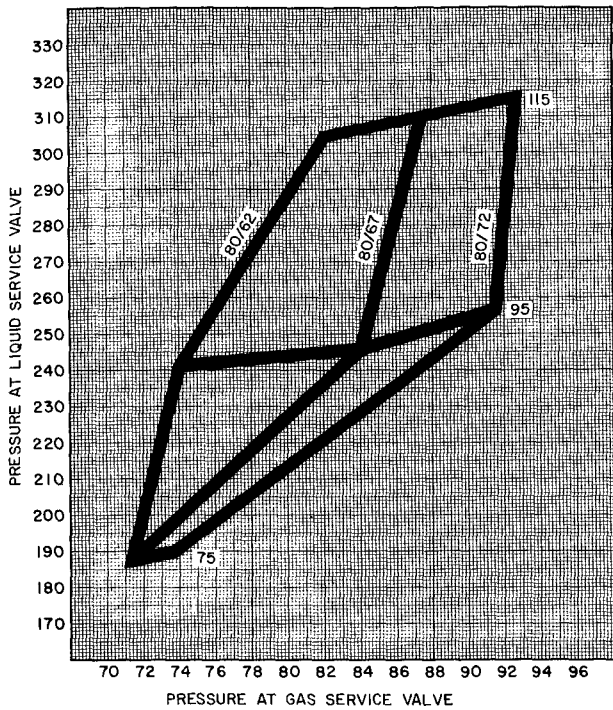

**Fig. 13 — 030, 3-Coil**

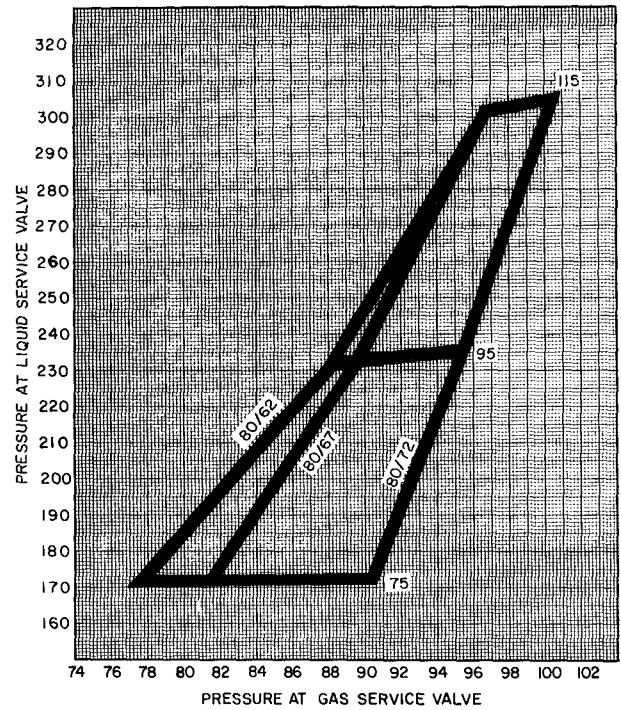

**Fig. 15 — 018, 3-Coil**

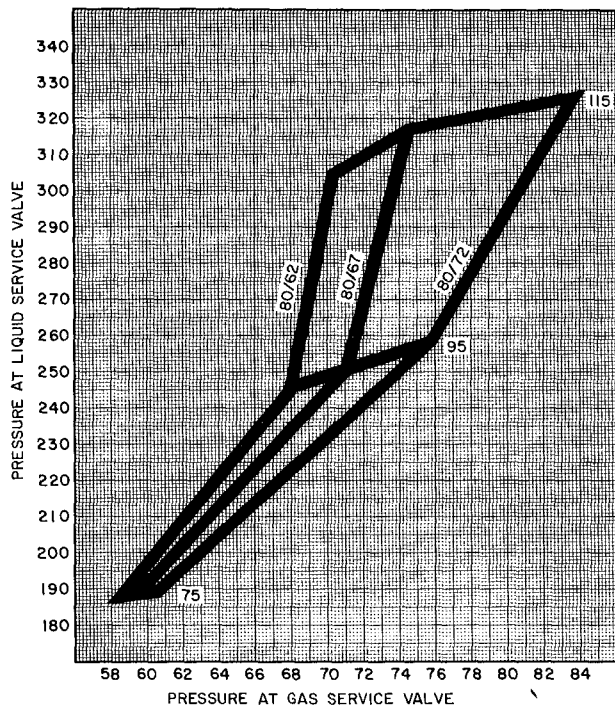

**Fig. 14 — 030, 2-Coil**

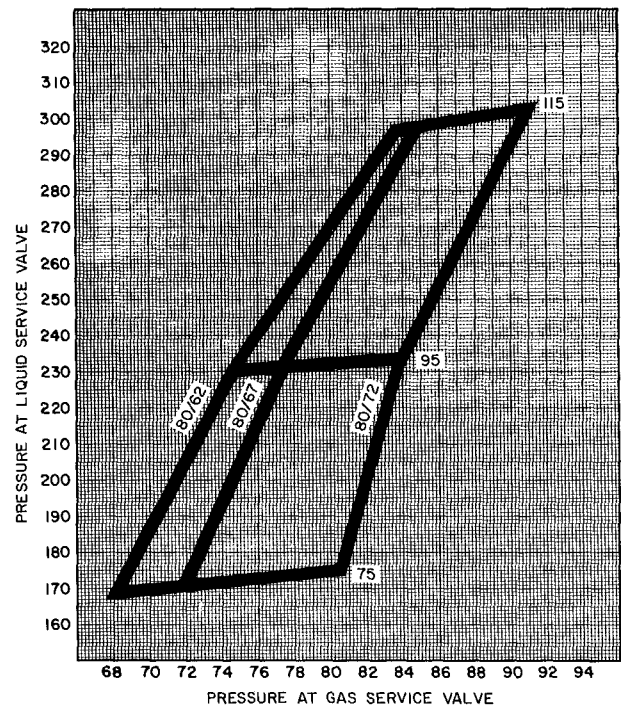

**Fig. 16 — 018, 2-Coil**

**START-UP**

1. Energize crankcase heater a minimum of 24 hours before starting unit. To energize heater only, set thermostat at OFF position and close electrical disconnect to outdoor unit.
2. Turn on main disconnect switch(es) to indoor and outdoor units.
3. Set fan switch as desired (ON or AUTO).
4. Set thermostat dial at desired temperature.
5. Set selector switch at COOL. Operate unit for 15 minutes.
6. Check indoor fan coil fan speeds for proper operation.

7. Check system operation using operational check charts provided. See Fig. 13 - 16.

NOTE: If system requires recharging, use weigh-in method. Do not use operational check charts for charging.

Motors and controls are designed to operate satisfactorily in the voltage range shown in Table 5. If necessary to use manifold gages for servicing, refer to Carrier Standard Service Techniques Manual, Chapter 1, Refrigerants, Page 1-5, Fig. 8 for bypass method of returning charge to system. Removal of liquid line charging hose without following these precautions could result in some loss of charge.

# OPERATIONAL CHECK CHARTS

## 38EHX COOLING ONLY

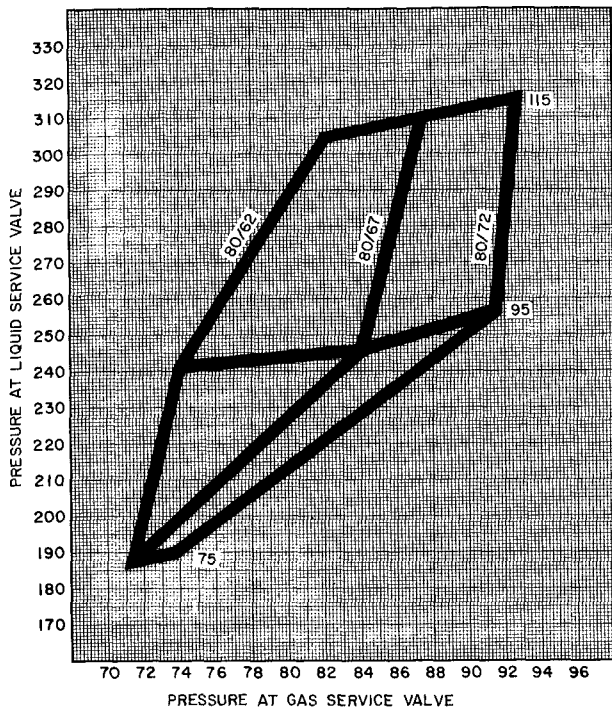

**Fig. 13 — 030, 3-Coil**

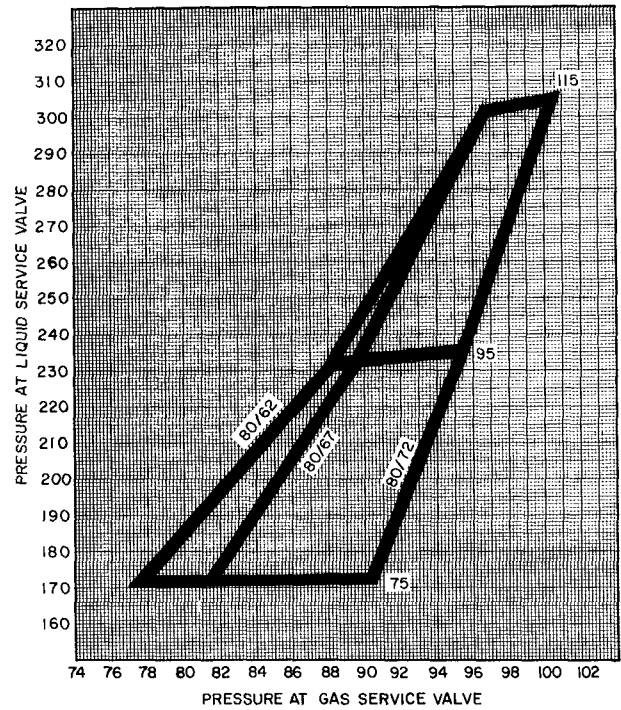

**Fig. 15 — 018, 3-Coil**

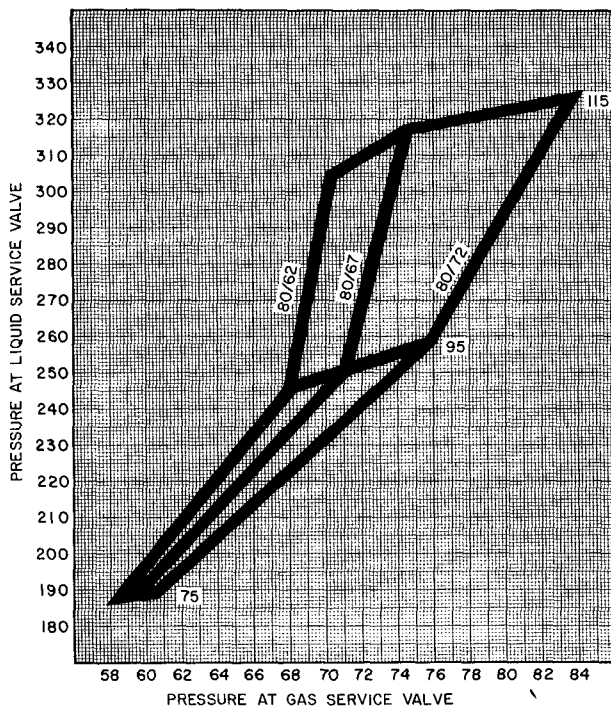

**Fig. 14 — 030, 2-Coil**

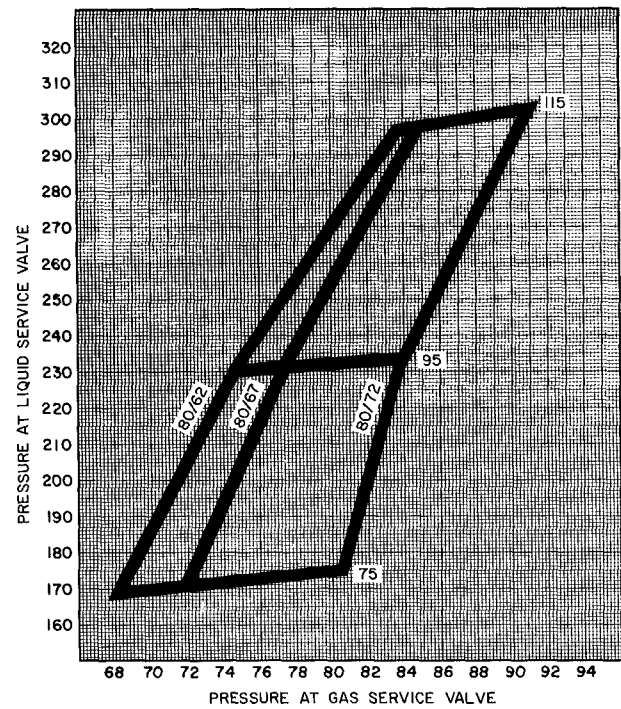

**Fig. 16 — 018, 2-Coil**

### START-UP

1. Energize crankcase heater a minimum of 24 hours before starting unit. To energize heater only, set thermostat at OFF position and close electrical disconnect to outdoor unit.
2. Turn on main disconnect switch(es) to indoor and outdoor units.
3. Set fan switch as desired (ON or AUTO).
4. Set thermostat dial at desired temperature.
5. Set selector switch at COOL. Operate unit for 15 minutes.
6. Check indoor fan coil fan speeds for proper operation.

7. Check system operation using operational check charts provided. See Fig. 13 - 16.

**NOTE:** If system requires recharging, use weigh-in method. *Do not* use operational check charts for charging.

Motors and controls are designed to operate satisfactorily in the voltage range shown in Table 5. If necessary to use manifold gages for servicing, refer to Carrier Standard Service Techniques Manual, Chapter 1, Refrigerants, Page 1-5, Fig. 8 for bypass method of returning charge to system. Removal of liquid line charging hose without following these precautions could result in some loss of charge.

## OPERATING INSTRUCTIONS

The Carrier Multiplex system for cooling fills the need for low installation and operating costs.

Multiplex system not only eliminates the need for installation of a duct system, but through the use of multiple (up to 3 per system) indoor fan coils, it also enables you to selectively control temperatures in individual rooms, thus saving energy costs. A manually operated thermostat in each room provides the desired energy management.

Multiplex is ideally suited for use in housing retrofit applications, motels, apartments, condominiums and small commercial structures. Four major components are utilized: an outdoor coil section, 2 or 3 indoor fan coils, the Multiplex control box that unites all sections and controls system operation, plus a room thermostat for each indoor fan coil for comfort control selection.

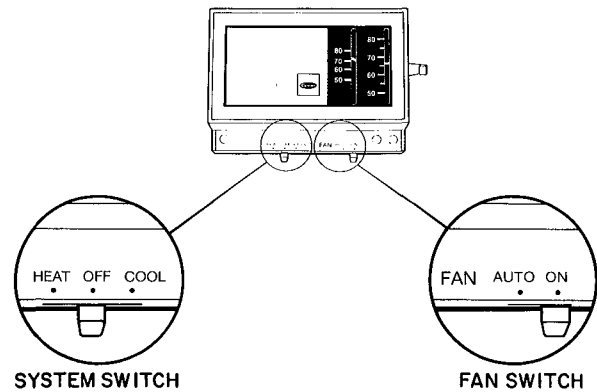

Fig. 17 — Multiplex Thermostat Operation

### Operating Characteristics

Individual room thermostats call for cooling. Compressor in outdoor condensing unit pumps refrigerant through Multiplex control box and then to individual room fan coils. Fan coils distribute cooled air while absorbing heat from rooms. Heat is transferred to outdoor unit where it is expelled to outdoor air.

### Operating your Multiplex System

1. Be sure power to system is turned ON.
2. Set room thermostats to temperatures desired in each room.
3. Set room thermostats to COOLING position.
4. Select fan speeds: high, medium or low. You may prefer different speeds for different rooms, depending on usage of the rooms.
5. If you do not wish to cool a particular zone, simply set thermostat at OFF position.
6. Be sure indoor fan coil units are not blocked by draperies, curtains, furniture, etc.

**THERMOSTAT OPERATION** (See Fig. 17) — Your Carrier Multiplex system can operate automatically all year long. The system is thermostatically controlled. Do not jiggle or frequently reset cooling thermostat lever.

**NOTE:** Setting cooling temperature lower than normal (78 F) results in increased energy consumption and higher operating costs.

- Initially set system switch at OFF.
- Set thermostat cooling control lever at desired temperature.
- Set fan switch at AUTO. (ON for continuous air circulation).
- Set system switch at COOL.

### Energy-saving tips

1. If a room is to be vacant for a period of time, set thermostat at OFF position to avoid unneeded use of energy. Turn off thermostats before going away on vacation or extended trips.
2. Do not allow fan coils to become blocked by furnishings. This prevents proper air circulation.
3. Check indoor fan coil filters (2 per coil, located side by side) periodically to be sure they are not clogged with dust. Clean if needed.
4. Try the lowest fan setting speed first. It may provide all the cooling you need.
5. Be sure there is no air seepage around windows. Check insulation around doors and windows.
6. On sunny days, if heat is needed, open drapes to allow sun's heat to enter room. In cooling season, close drapes to reduce heat gain through windows.

## MAINTENANCE

**Personal Safety Considerations** — Installing and servicing air conditioning equipment can be hazardous due to system pressure and electrical components. Only trained and qualified service personnel should install or service air conditioning equipment.

Untrained personnel can perform basic maintenance functions such as cleaning *indoor* coils and cleaning and replacing filters. All other operations should be performed by trained service personnel. When working on air conditioning equipment, observe precautions in literature, and on tags and labels attached to unit.

Follow all safety codes. Wear safety glasses and work gloves.

### ⚠ WARNING

Before performing service or maintenance operations, turn off main power switches to indoor and outdoor units. Electrical shock can cause personal injury.

If electricity is interrupted during operation, **TURN OFF** system at all thermostats before restarting. Otherwise damage can result. Keep in mind there is a built-in *5-minute* time delay that takes place before system restarts.

**Maintenance By Service Technician** — At least once each year, system should be inspected by a properly trained service technician. Technician should:

1. Check, and clean when necessary, outdoor and indoor coils.  
NOTE: Owner should not attempt to clean outdoor coil under any circumstances to avoid damage to coil and personal injury.
2. Check, and clean when necessary, indoor coil drain pan and hose connections.
3. Inspect and clean indoor coil blower wheel and housing.
4. Inspect and change or clean air filters, if necessary.
5. Check all piping connections for possible leaks.
6. Inspect electrical wiring, connections and components for loose connections and wear.
7. Lubricate outdoor unit fan motor.
8. Perform operational check to determine whether unit is working properly and efficiently, and whether adjustments are needed.

**SERVICE CONTRACT PROTECTION** — A Carrier planned maintenance service contract provides regular inspection and maintenance service at reasonable cost. This assures long, troublefree equipment operation. Contact your local Carrier dealer for details.

### ⚠ CAUTION

Before doing any cleaning, be sure that power to all unit components is turned off. Do not wash filter in water over 120 F (to avoid shrinkage). Do not expose filter to fire (to avoid fire damage). Do not expose filter to direct sunlight. Clean filter more frequently when air is extremely dirty. *Do not* attempt to clean or service components in control box.

## Cleaning Air Filters (see Fig. 18)

1. Remove filters by pulling straight down.
2. Wash dust off filter with clean, warm (not over 120 F) water, or use a vacuum to clean filter.
3. Dry filter carefully. After cleaning, replace in its original position. If air filter is not replaced, dust gathers in air conditioner and operation becomes impaired.

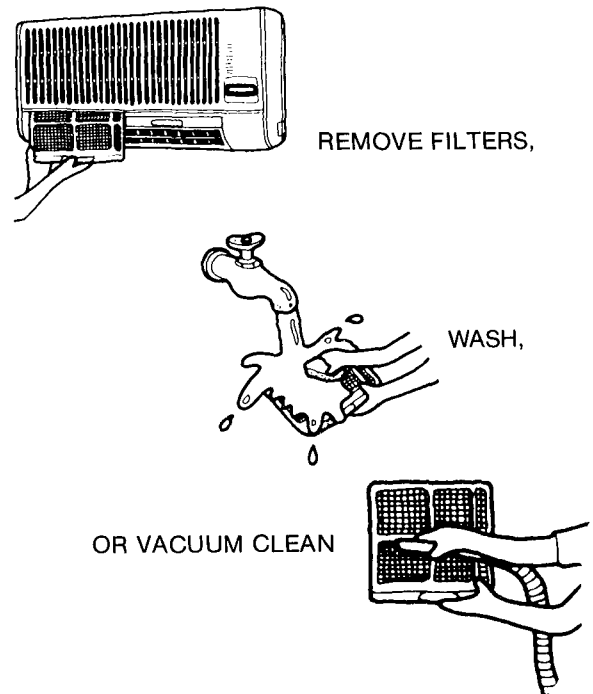

Fig. 18 — Air Filter Maintenance

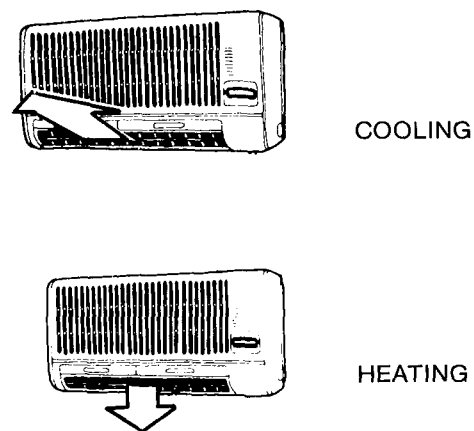

Fig. 19 — Air Discharge Direction

**Air Direction (see Fig. 19)** — For cooling, rotate long air discharge grille louvers straight outward (not upward or downward).

For heating, rotate grille downward to direct warm air toward floor.

Turn vertical discharge vanes to left or right to direct warm or cool air toward room occupants.

**Cleaning Indoor Unit** — Dust or wipe exterior cabinet lightly with soft cloth. If extremely dirty, use soft cloth dampened with water and ordinary household detergent. *Do not* use water over 120 F to clean indoor cabinet. Do not use harsh cleaners such as benzene, gasoline, thinner, etc.

**TO CLEAN INDOOR COIL** — Remove cabinet front. Vacuum coil fins, being very careful not to bend or damage fins, as this will affect operating performance. Also vacuum indoor coil blower motor area.

**Before Calling for Service** — You may save the cost of a service call by following these simple procedures:

Turn thermostats to OFF. Wait 5 minutes. Turn thermostats ON, and to COOL. If system starts, you may not need a service call. If system does not start, check Table for typical corrective actions.

**SYSTEM FAILS TO OPERATE** — Be sure thermostats are not turned to OFF. Be sure power to system is ON. Be sure fuse or circuit breaker has not tripped. If necessary, call Carrier dealer for service.

**Table 6 — Troubleshooting**

SYMPTOM & CAUSE	ACTION
<b>Insufficient Airflow:</b>	
1 Dirty filters	1 Clean and replace filters. If a filter is damaged, contact dealer
2 Blocked indoor coil louvers	2 Clean air discharge louvers
<b>Inadequate Cooling:</b>	
1 Dirty indoor coil	1 Clean coil per directions
2 Air leaks in room	2 Check windows and doors and insulate where necessary
3 Dirty outdoor coil	3 Contact Carrier dealer for service

**Owner's Record** — Record and retain below the information your service technician needs to know about your Multiplex system. To find model and serial numbers, refer to nameplates on each section of system.

Dealer Name \_\_\_\_\_

Address \_\_\_\_\_

City \_\_\_\_\_ State \_\_\_\_\_

Dealer Phone \_\_\_\_\_ Date System Installed \_\_\_\_\_

System Model Nos.                      System Serial Nos.

Outdoor Section \_\_\_\_\_

Indoor Section \_\_\_\_\_

Control Box \_\_\_\_\_

Manufacturer reserves the right to discontinue, or change at any time, specifications or designs without notice and without incurring obligations.

Book 1 4  
Tab 3a 2a

PC 111

Catalog No 535-307

Printed in U S A

Form 53MX-1SI

Pg 16

12-87

Replaces: New

For replacement items use Carrier Specified Parts

Download from [Www.Somanuals.com](http://www.Somanuals.com). All Manuals Search And Download.



## Free Manuals Download Website

<http://myh66.com>

<http://usermanuals.us>

<http://www.somanuals.com>

<http://www.4manuals.cc>

<http://www.manual-lib.com>

<http://www.404manual.com>

<http://www.luxmanual.com>

<http://aubethermostatmanual.com>

Golf course search by state

<http://golfingnear.com>

Email search by domain

<http://emailbydomain.com>

Auto manuals search

<http://auto.somanuals.com>

TV manuals search

<http://tv.somanuals.com>