

Biesemeyer^{fi} T-Square^{fi} Commercial Fence Systems

50 Capacity (Model 78-904)

30 Capacity (Model 78-907)

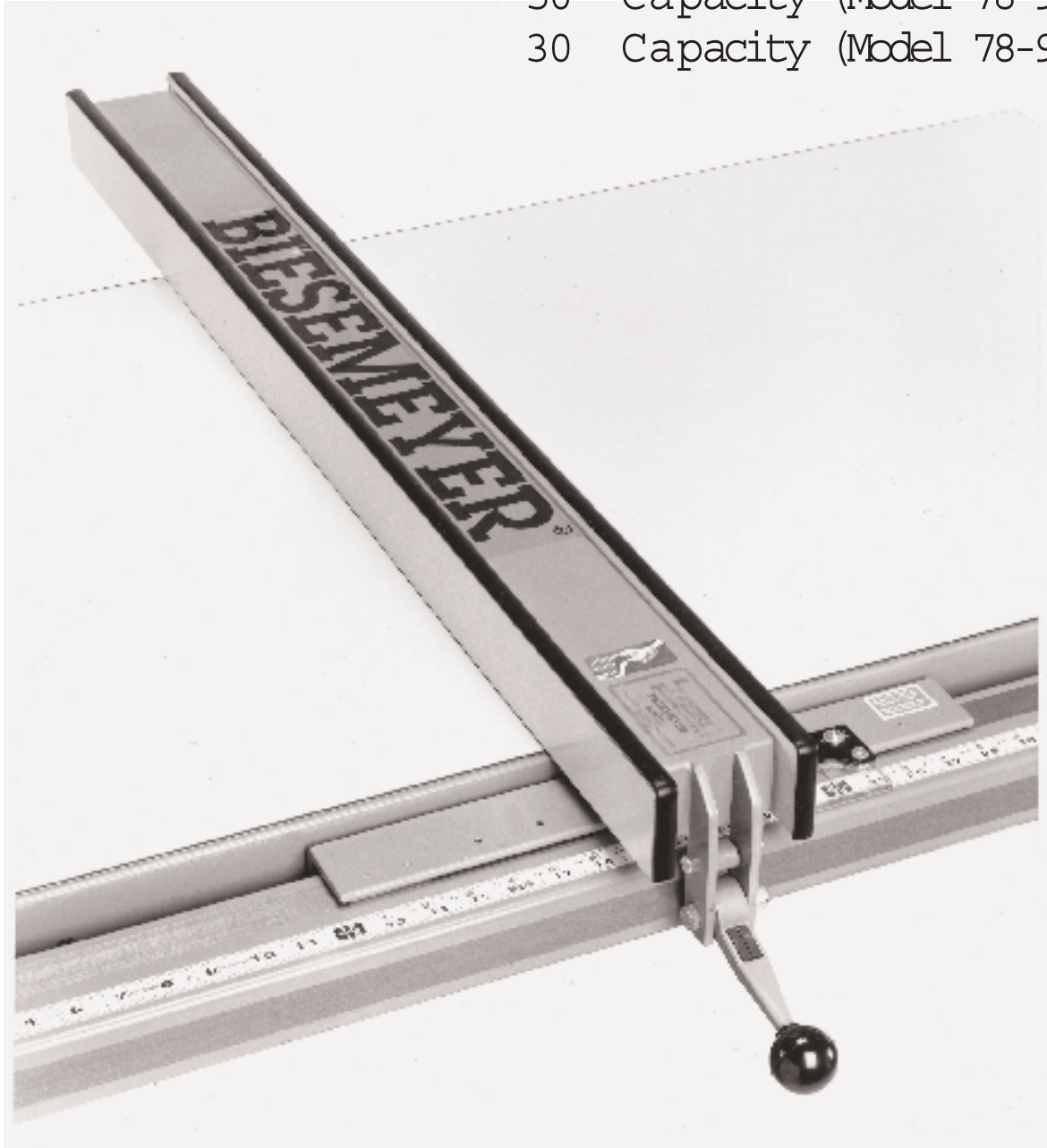

DATED 3-5-96

PART NO. 1349984

Delta International Machinery Corp. 1996

INSTRUCTION MANUAL

 **DELTA**

INTRODUCTION

The 50 capacity (model 78-904) and 30 capacity (model 78-907) Biesemeyer^{fi} T-Square^{fi} Commercial fence systems are specially designed to be used with:

Delta 10 Tilting Arbor Unisaws^{fi}
Delta 10 Tilting Arbor Saws
Delta 10 Contractor s^{fi} Saws
Delta 10 Contractor s^{fi} Saws II

The T-Square^{fi} Commercial Fence Systems include the fence assembly, front rail, rear rail and front guide tube. The accessory right extension table (78-925 for 50 capacity model and 78-927 for 30 capacity model) must be ordered separately or a similar extension table must be constructed by following instructions in this manual. The accessory leg kit (model 78-952), used to support the extension table, must also be ordered separately. IMPORTANT: The T-Square^{fi} Fence System is designed to be used ONLY with a supporting extension table.

The following instructions illustrate assembling the T-Square^{fi} Commercial Fence System to a Delta 10 Tilting Arbor Unisaw^{fi}. Instructions for assembling the fence system to Delta 10 Tilting Arbor Saws and 10 Contractor s^{fi} Saws are identical unless otherwise noted.

UNPACKING

Carefully unpack the T-Square^{fi} fence system from the shipping carton(s). Figure 2 illustrates all the items supplied with the 78-904 and 78-907 fence system.

- | | |
|---|---|
| 1 - Rear Rail | for fastening front rail to saw table and sheet metal extension wing if applicable |
| 2 - Front Rail | |
| 3 - Guide Tube | 16 - 3/8-16 x 1-1/4 long flat head Phillips screws (3) |
| 4 - T-Square ^{fi} Fence Assembly | 17 - 7/8 O.D. flat washers (3) |
| 5 - Switch Adapter for Unisaws ^{fi} | 18 - Lock washers (3) |
| 6 - Switch Adapter for Contractor s ^{fi} Saws | 19 - 3/8-16 hex nuts (3) |
| 7 - Cable Strap | for fastening guide tube to front rail |
| 8 - Template for aligning front rail to saw table | 20 - 1/2 long hex screws (7) |
| for fastening front and rear rails to right extension table | 21 - Lock washers (7) |
| 9 - 1-1/2 long flat head Phillips screws (14) | for fastening on-off switch adapter to guide tube where applicable on Unisaws ^{fi} or Contractors ^{fi} Saws |
| 10 - 1-1/4 O.D. Flat Washers (14) | 22 - 3/4 long hex head screws (2) |
| 11 - 1/4-20 hex nuts (14) | 23 - Lock washers (2) |
| for fastening rear rail to saw table and sheet metal extension wing if applicable | for fastening on-off switch to switch adapter where applicable on Contractor s ^{fi} Saws |
| 12 - 3/8-24 x 1-1/4 long hex head cap screws (3) | 24 - 3/8-16 x 1 long hex head screw (1) |
| 13 - 7/8 O.D. flat washers (3) | 25 - 7/8 O.D. Flat washer (1) |
| 14 - Lock washers (3) | 27 - Hex nut (1) |
| 15 - 3/8-24 hex nuts (3) | |

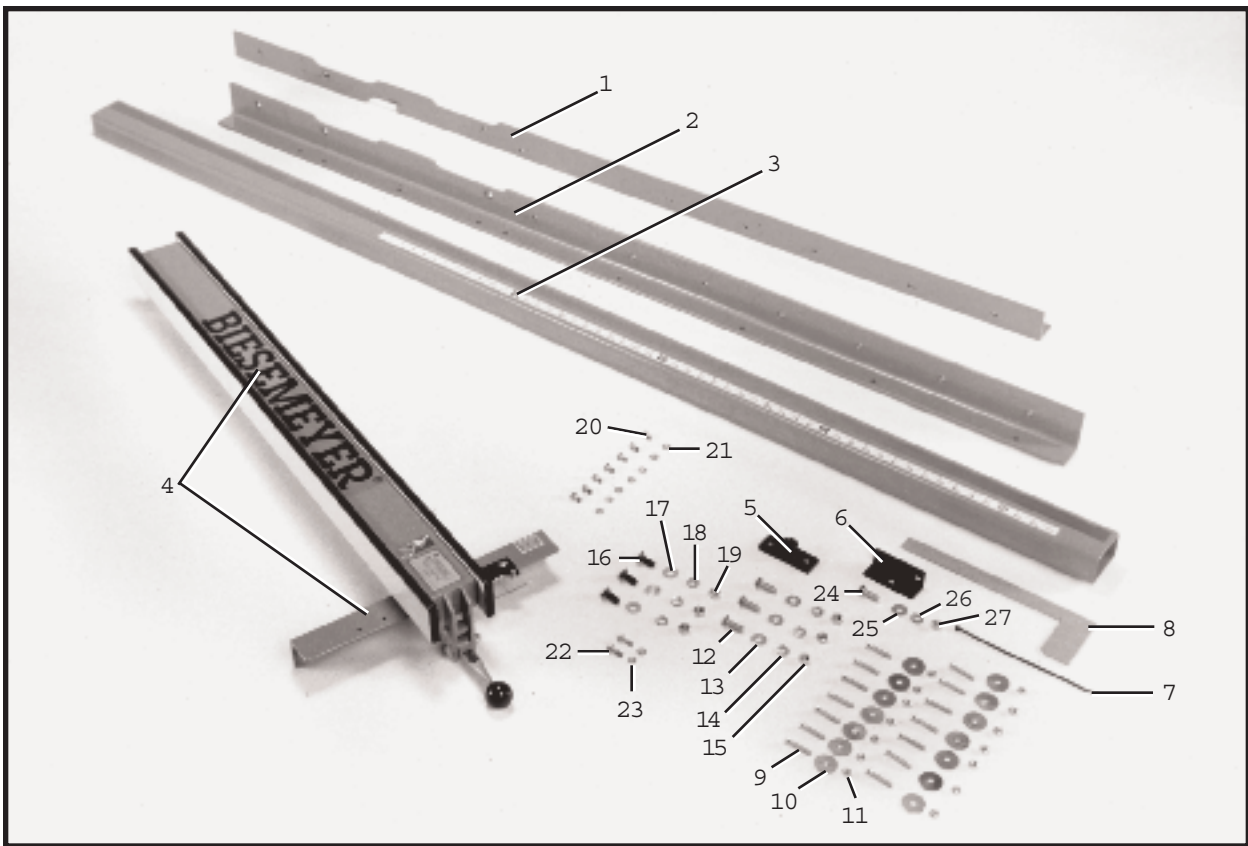

Fig. 2

If you purchased the accessory right extension table (model 78-925 for 50 capacity fence or model 78-927 for 30 capacity fence) carefully unpack the extension table from the shipping container. Figure 3 illustrates the right extension table removed from the container. NOTE: If you did not purchase the accessory right extension table for use with your T-Square[®] fence, refer to the ASSEMBLY INSTRUCTION section of this manual for information on constructing a right extension table.

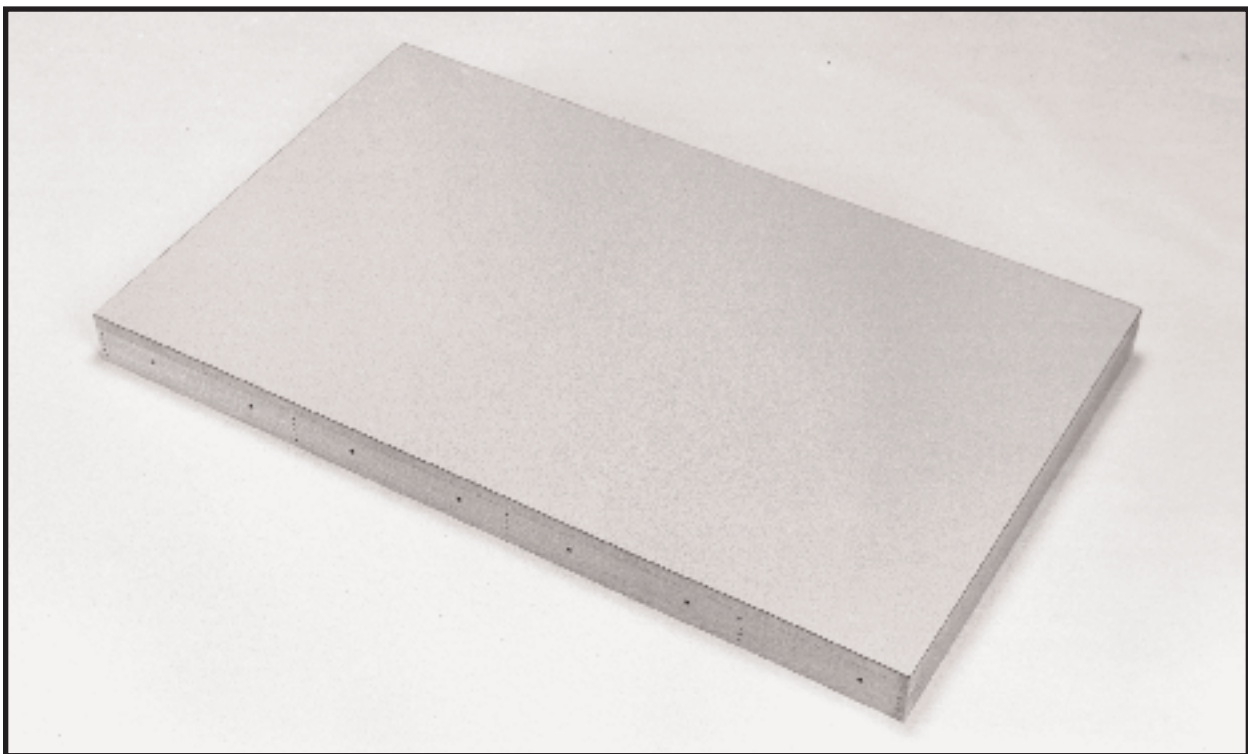

Fig. 3

If you purchased the accessory leg kit (model 78-952) for use with the right extension table, Figure 4 illustrates the legs and loose items supplied with this accessory.

- 1- Legs (2)
- 2- 5/8 long wood screws #8 (8)
- 3- 1/4-20 x 1-1/2 long flat head Phillips screws (4)
- 4- 1/4 flat washers (4)
- 5- 1/4-20 hex nuts (4)

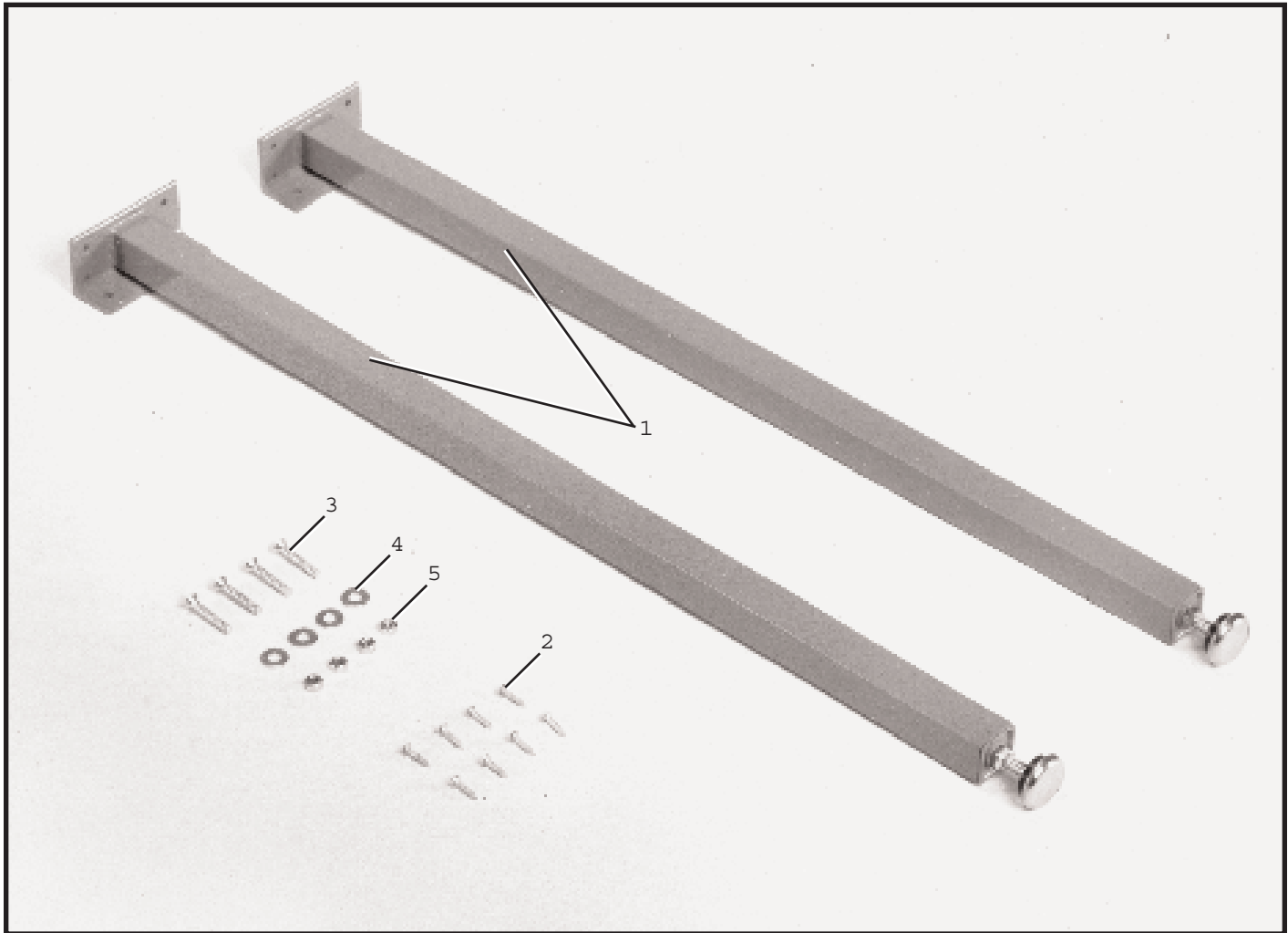

Fig. 4

ASSEMBLY INSTRUCTIONS

When retrofitting the T-Square[®] Fence System to table saws that have been equipped with original equipment fence, guide rails and extension wings, remove the fence, front and rear guide rails and right hand extension wing from the saw. If you purchased the saw and T-Square[®] fence system as a promotional item, assemble the saw as explained in the machine instruction manual and proceed to assemble the T-Square[®] fence to the saw as follows:

- 1 DISCONNECT THE SAW FROM THE POWER SOURCE.

2. Assemble the front rail (A) Fig. 5, to front of saw table using the two 3/8-16 x 1-1/4 long flat head Phillips screws (B), 7/8 flat washers, lock washers and 3/8-16 hex nuts supplied. Screws (B) are inserted through the two holes in the front rail, as shown and through the two through holes in the front of the saw table and fastened to the table with the flat washers, lockwashers and hex nuts IMPORTANT: Do not completely tighten front rail mounting hardware at this time.

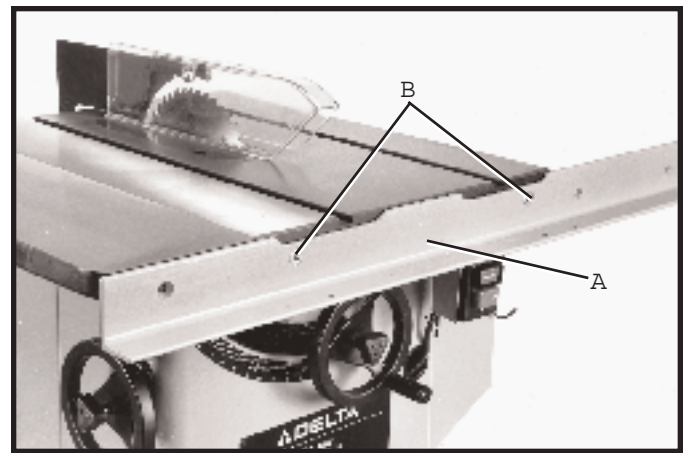

Fig. 5

3. Using the template (D) Figures 6 and 7, check and adjust front rail at both ends of the saw table as shown, to make sure rail (A) is level with table surface and tighten rail mounting hardware (B). IMPORTANT: Template (D) must be on saw table when checking, not on extension wing.

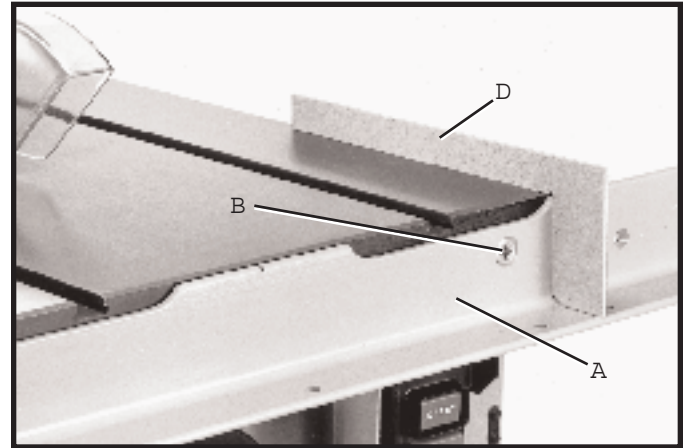

Fig. 6

4. Assemble rear rail (E) Fig. 8, to rear of saw table using the two 3/8-24 x 1-1/4 long hex head screws (F), 7/8 flat washers and lockwashers as shown. NOTE: When mounting fence to Unisaws, the two screws (F) are threaded into the threaded holes in the saw table, as shown. When mounting fence to 10 Tilting Arbor Saws or 10 Contractor's Saws, through holes are provided instead of threaded holes on the rear edge of the saw table. In this case the rear rail (E) is fastened to the table with the two hex head screws (F) and the flat washers, lockwashers and hex nuts will be inside the rear edge of the saw table.

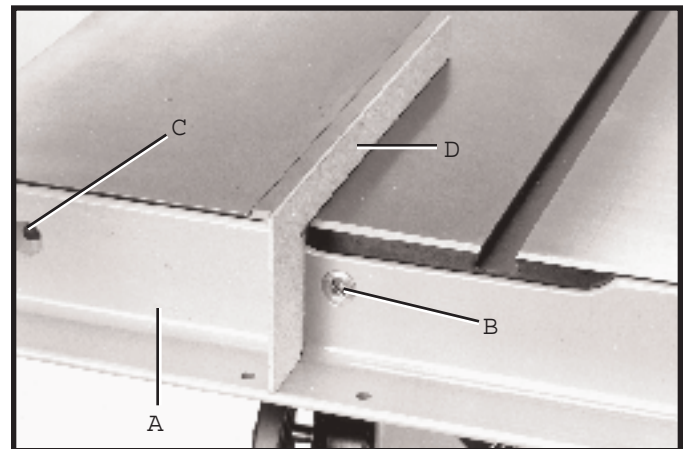

Fig. 7

5. Make certain top edge of rail (E) Fig. 8 is below table surface and that top edge of cut-outs (G) are below miter gage slots before tightening screws (F).

6. If the table saw is equipped with a left hand sheet metal extension wing, fasten the front rail (A) Fig. 7, to the sheet metal extension wing with the 1-1/4 long flat head Phillips screw through hole (C) Fig. 7, in the front rail and through the slot in the sheet metal extension wing. Fasten the rear rail (E) Fig. 8, to the sheet metal extension wing with the 1-1/4 long hex head screw through hole (H) Fig. 8, in the rear rail and through the slot in the sheet metal extension wing. Fasten both the front and rear rails in place using the flat washers, lock washers and hex nuts supplied.

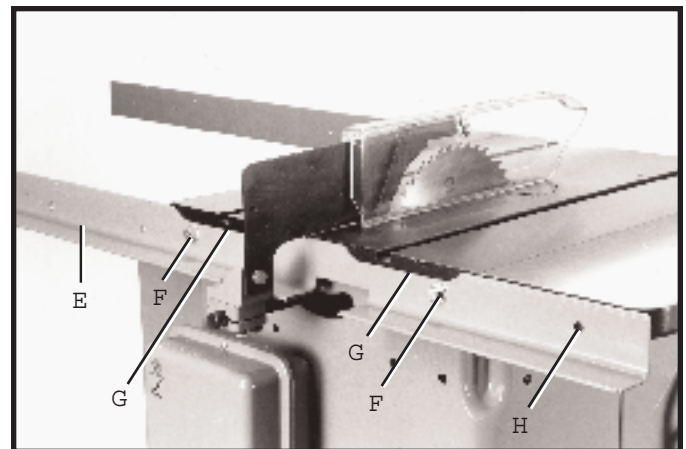

Fig. 8

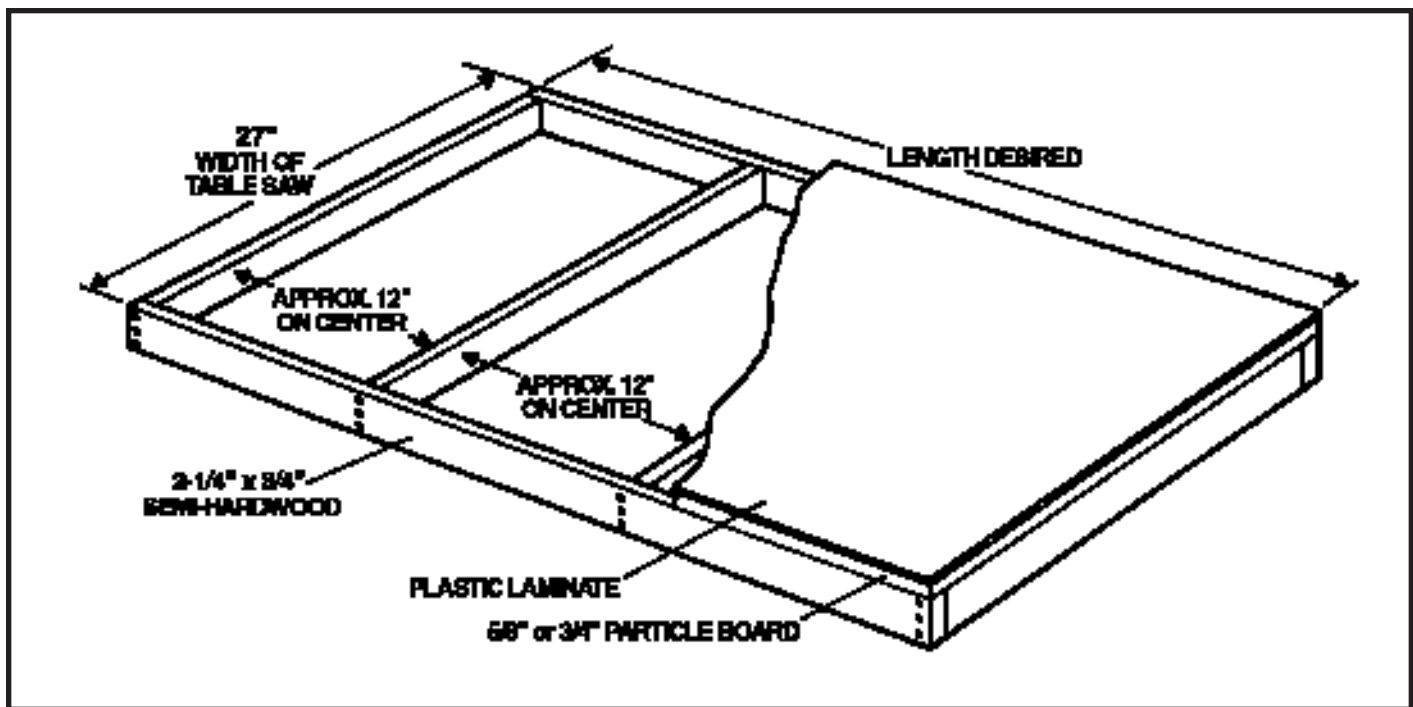

Fig. 9

7. If you did not purchase the accessory right extension table for use with your T-Square[®] fence, construct an extension table by following the dimensions shown in Fig. 9.

8. Position the two legs (H) Fig. 10, at the two far corners of the inside of one end of the extension table, as shown, and mark the position of the eight holes to be drilled into the bottom of the table. **IMPORTANT:** If your saw and fence system will be used with a mobile base underneath the saw base and table legs, the position of the legs may have to be changed to fit onto the mobile base. Remove the two legs (H) and using a 1/16" drill bit, drill the eight holes 1/2" deep. Replace the two legs (H) and fasten to the bottom of the table using the eight 3/4" long wood screws (I) supplied.

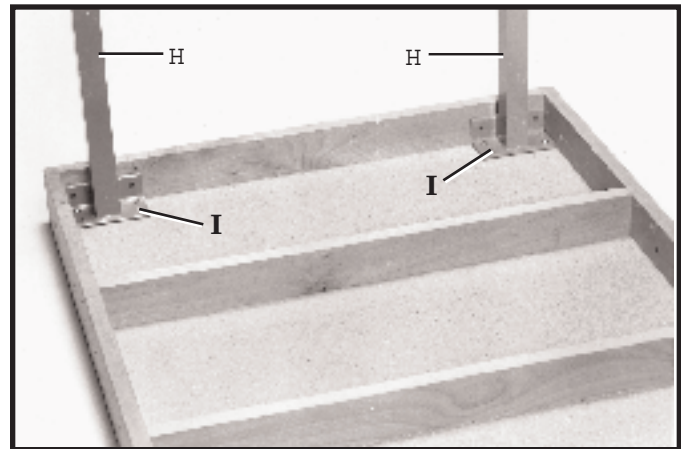

Fig. 10

9. Figure 11 illustrates one of the legs (H) fastened to the bottom of the extension table with the four wood screws (I). Using a 1/4" drill bit, drill two through holes through the end piece (J) of the table using the two holes (K) as a template.

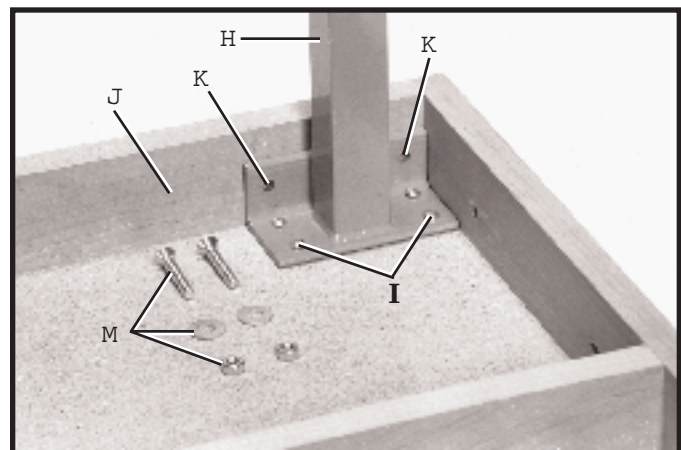

Fig. 11

10. Fasten the leg bracket (L) Fig. 12, to the end piece (J) of the table using the two 1-1/2 long flat head Phillips screws, flat washers and hex nuts (M) Figs. 11 and 12. Fasten the remaining leg to the extension table in the same manner.

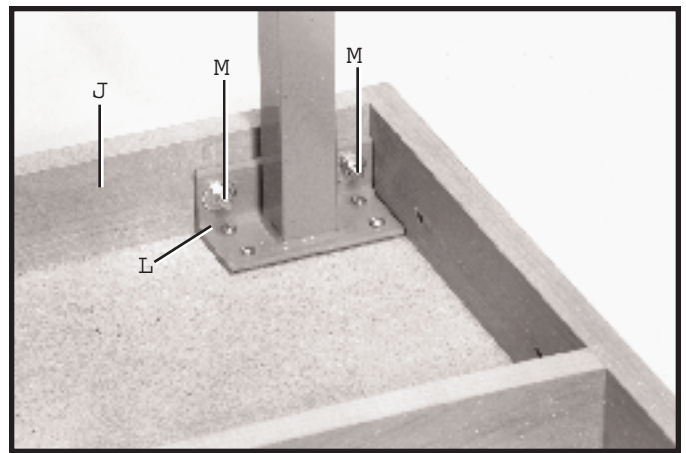

Fig. 12

11. Figure 13 illustrates the two legs (H) assembled to the bottom of the table.

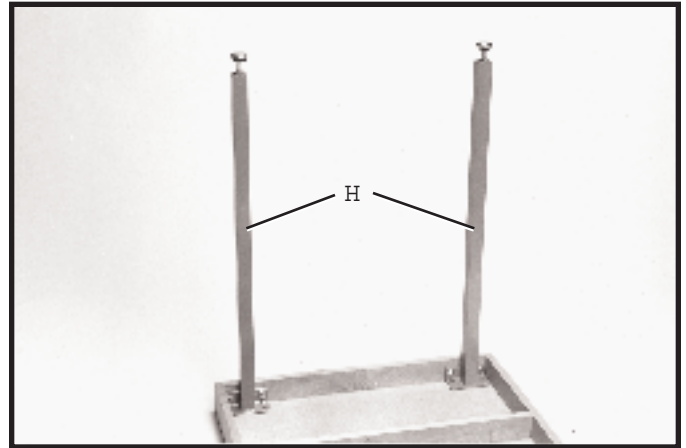

Fig. 13

12. Place table assembly (N) Fig. 14, in position between the two rails, as shown. Make sure end of table (O) is flush against saw table (P) and using a bar clamp (Q) snug up end of rails to hold table in position. Using a straight edge make sure table (O) is in the same plane and level with saw table (P). Lightly tap table up or down and adjust leveling screws (R) Fig. 15, in bottom of legs to accomplish this. When you are certain table (O) Fig. 14, is level and in the same plane with saw table (P), tighten bar clamp (Q) to hold everything in position. Then drill 1/4 through holes through the front and rear of the extension table using the holes (S) provided in rails as template. NOTE: Number of holes (S) in the front and rear rails will vary depending on the length of the rails you purchased.

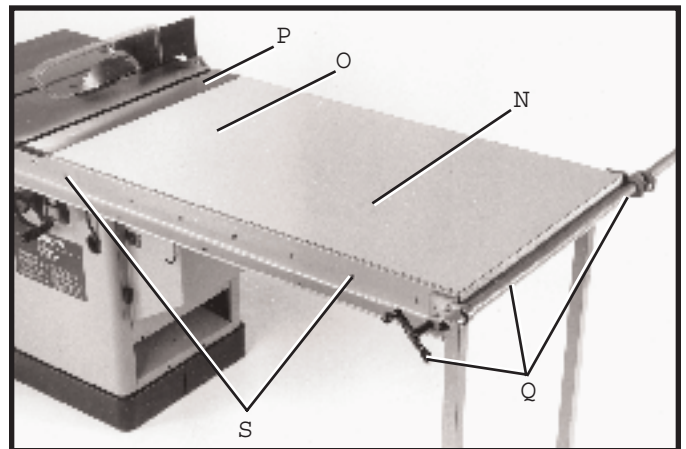

Fig. 14

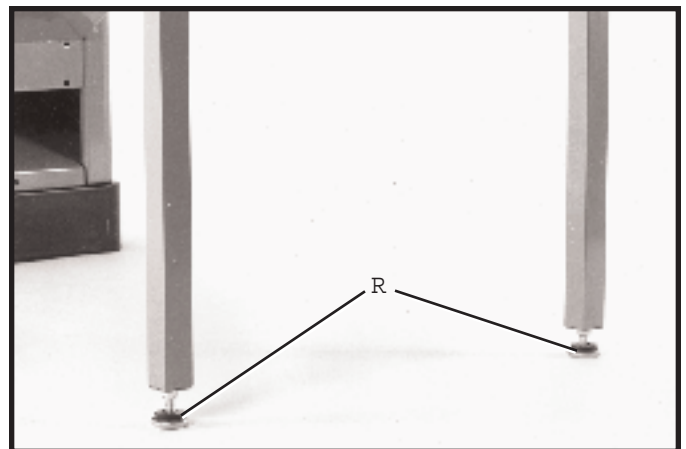

Fig. 15

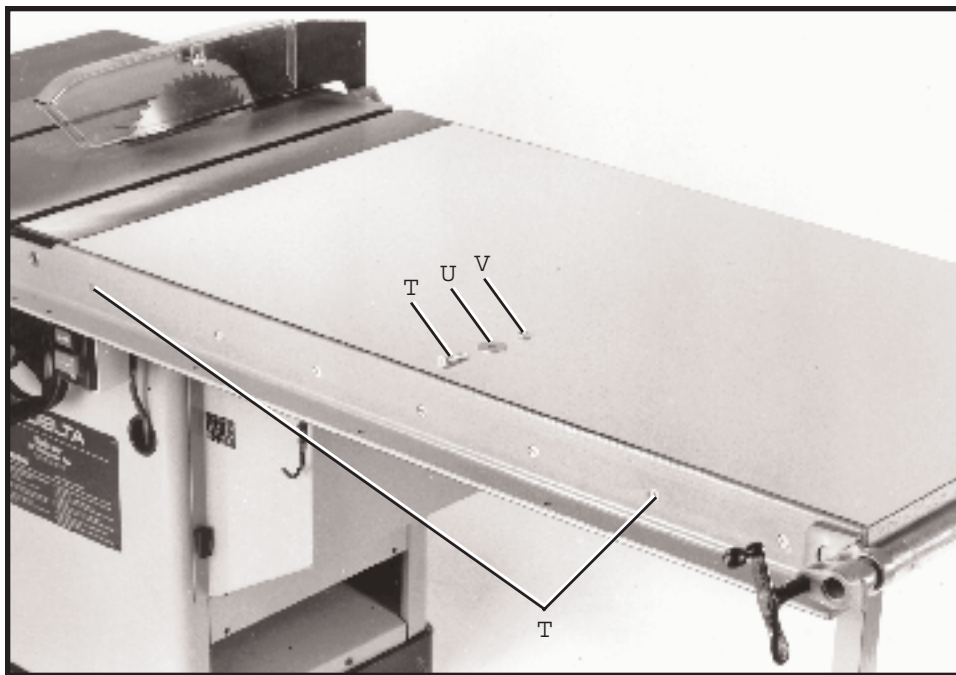

Fig. 16

13. After the holes have been drilled in the edge of the front and rear extension table board, fasten both front and rear rail to table using the 1-1/2 flat head Phillips screws (T) Fig. 16, 1-1/4 O.D. flat washers (U) and hex nuts (V).

14. If you are assembling the T-Square[®] fence to a Delta Unisaw[®] that has the on-off switch (W) Fig. 17, suspended from the bottom of the saw table, as shown, remove the switch and nipple (W) from the bottom of the saw table.

15. Assemble the switch and nipple (W) Fig. 18, to switch adapter for Unisaws (X) supplied with your T-Square fence.

16. Figure 19 illustrates the switch and nipple (W) assembled to the switch adapter (X). The switch adapter will be fastened to the front rail (A) and guide tube through holes (Y) in the front rail after the guide tube is fastened to the front rail (A).

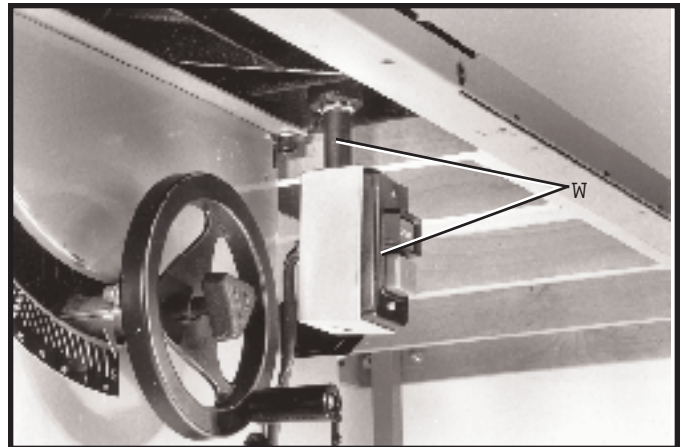

Fig. 17

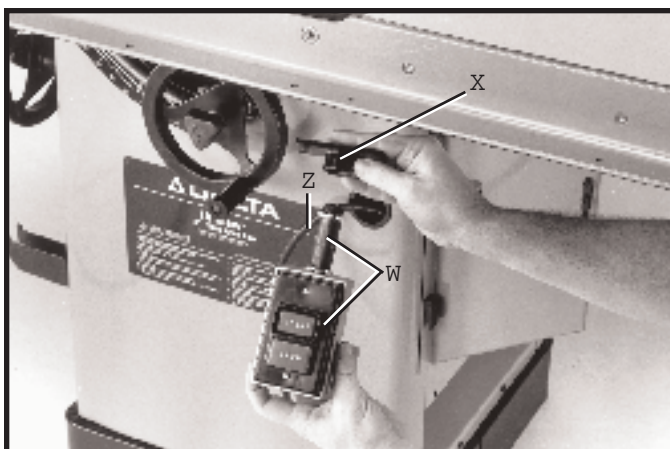

Fig. 18

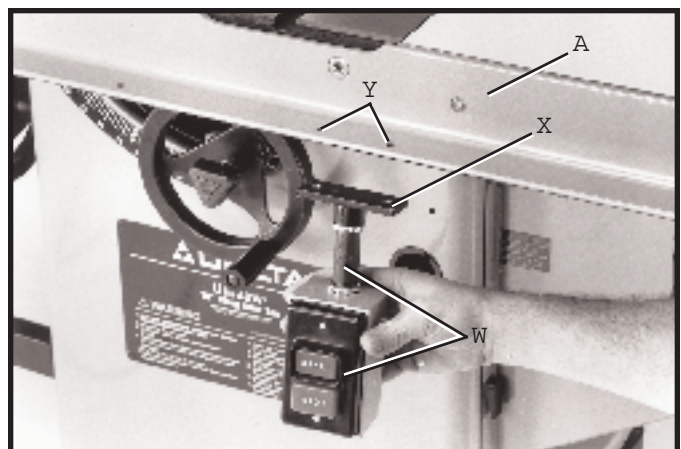

Fig. 19

17. Lay the guide tube (B) Fig. 20, on the saw table as shown, and line up the threaded holes (C) on bottom of guide tube (B) with the through holes (D) on the front rail (A). IMPORTANT: If a switch adapter is being used for Unisaws or 10 Contractor's Saws to mount the switch to the rail and guide tube, holes (E) are used to mount the Unisaw switch adapter and holes (F) will be used for the Contractor's Saw switch adapter.

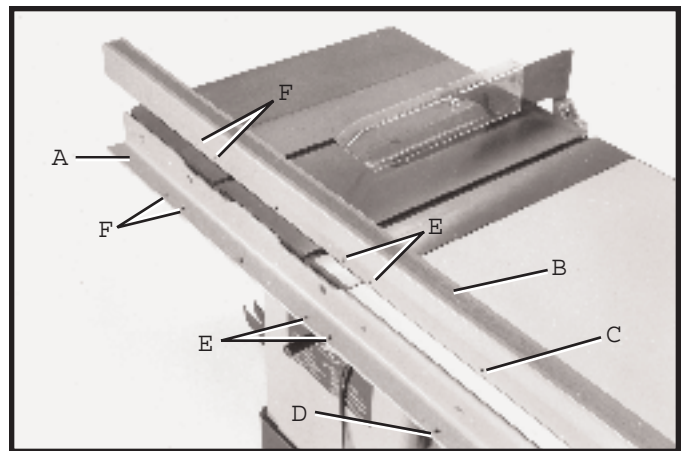

Fig. 20

18. Position the guide tube (B) Figs. 21 and 22, on the front rail and fasten the guide tube to the rail using the 1/2" long hex screws (G) and lockwashers in all of the holes except the ones used to fasten the switch adapter if applicable.

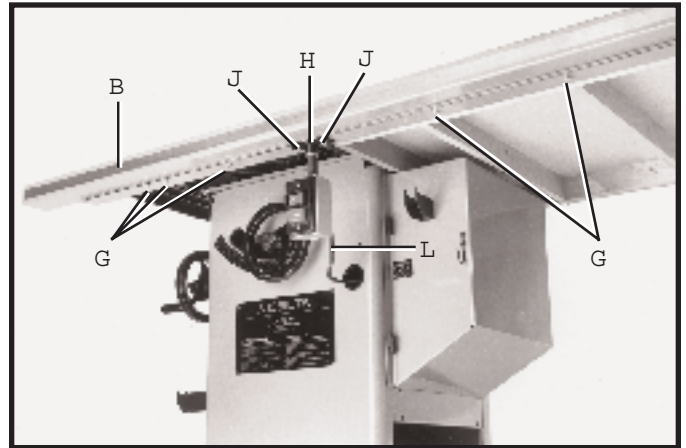

Fig. 21

19. Figure 21 illustrates the Unisaw switch adapter (H) mounted to the front rail and guide tube using two 3/4" long hex screws (J) and lockwashers.

20. Figure 22 illustrates the Contractor's Saw switch adapter (K) mounted to the front rail guide tube using two 3/4" long hex screws (J) and lockwashers.

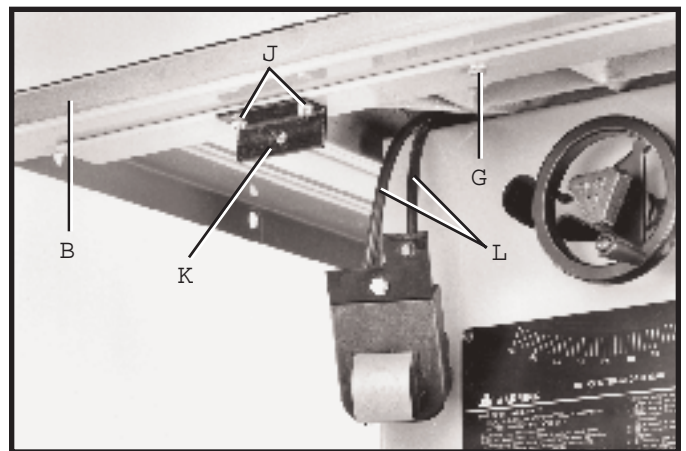

Fig. 22

21. NOTE: If there is not enough cord (L) Figs. 21 and 22, available to pull out and reposition the switch, simply cut the cable strap holding the cord to the inside of the saw cabinet. After switch is repositioned, make certain that the cord does not come into contact with the saw blade and use the cable clamp supplied with the fence to hold the cord in position.

22. On the Contractor's Saw, attach the switch (M) Fig. 23, to the switch adapter (K) using the 1" long hex screw (N), flat washer, lockwasher and hex nut supplied.

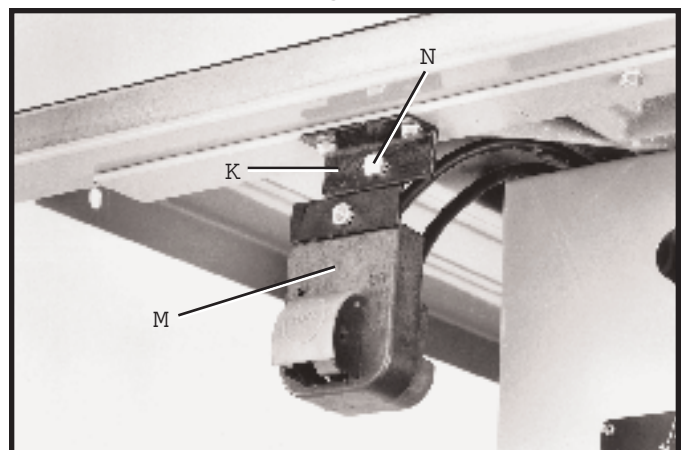

Fig. 23

FENCE OPERATION

IMPORTANT: Before operating fence, make sure the fence is adjusted parallel to the miter gage slot, as explained later on in this manual

1. To move the fence along the guide rail, simply lift up clamp lever (A) as shown in Fig. 24, slide fence to desired position on rail, and push down on clamp lever (A) as shown in Fig. 25, to lock fence in position. **NOTE:** A magnet (E) Fig. 25, is provided to hold clamp handle (A) Figs. 24 and 25, in the up position when moving the fence.

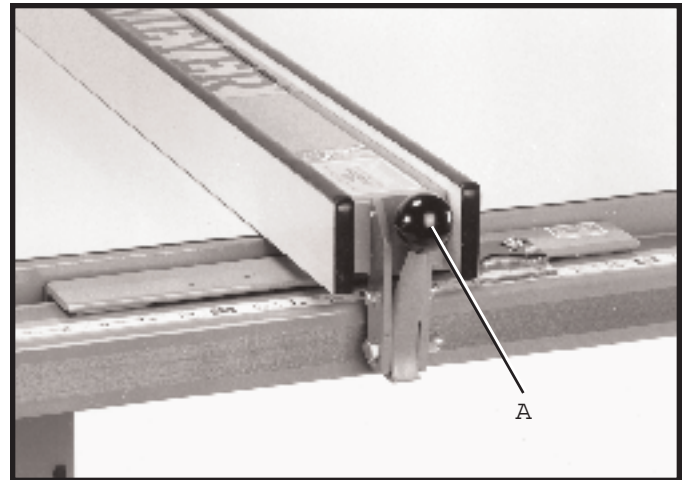

Fig. 24

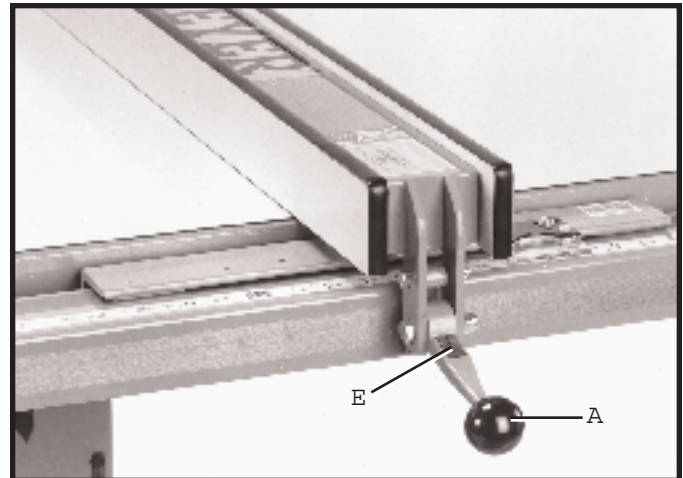

Fig. 25

2. The distance the fence is positioned away from the blade is indicated by the witness line (B) Fig. 26, located on the cursor (C). If it is necessary to adjust the cursor (C), make a test cut with the fence locked in position. Measure the width of the finished cut and adjust the cursor (C) by loosening the two screws (D), adjusting the cursor (C) until the witness line (B) is aligned with the same marking on the scale as the finished cut. Then tighten the two screws (D).

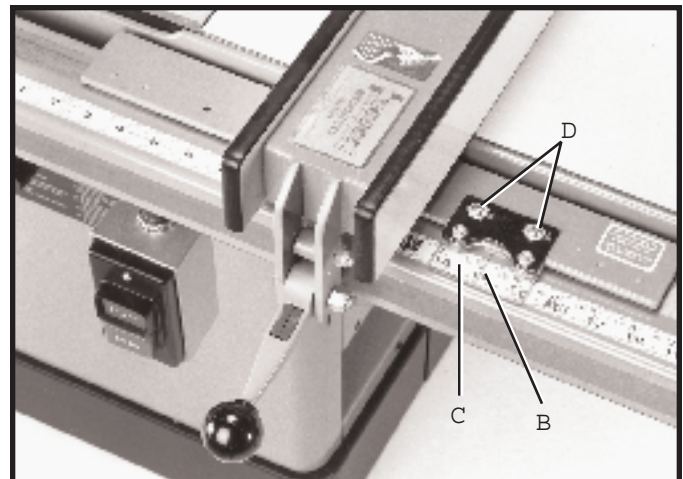

Fig. 26

ADJUSTING FENCE PARALLEL TO MITER GAGE SLOTS

NOTE: Delatatable saws have been aligned at the factory so that the miter gage slots in the table are parallel with the saw blade. It is recommended, however, to check and make certain this alignment is correct before adjusting the fence parallel to the miter gage slot as follows:

The fence (A) Fig. 27, must be adjusted so it is parallel to the miter gage slots (B). To check and adjust, move fence (A) until the bottom edge of the fence is in line with the edge of one of the miter gage slots as shown, and push down on the fence clamping lever (C). Check to see if the fence (A) is parallel to the miter gage slot the entire length of the table. If an adjustment must be made, lift up fence locking lever (C) and raise fence up off the guide tube, as shown in Fig. 28. Slightly tighten or loosen one of the two adjusting screws (D) or (E) Fig. 28, using a 3/16 allen wrench (F), not supplied. Replace the fence on the guide tube and check again to see if the edge of the fence is parallel with the miter gage slot the entire length of the slot. Repeat this adjustment until you are sure the fence is parallel with the miter gage slot. **IMPORTANT: VERY LITTLE MOVEMENT OF SCREWS (D) AND (E) IS NECESSARY TO ADJUST THE FENCE PARALLEL WITH THE MITER GAGE SLOT.**

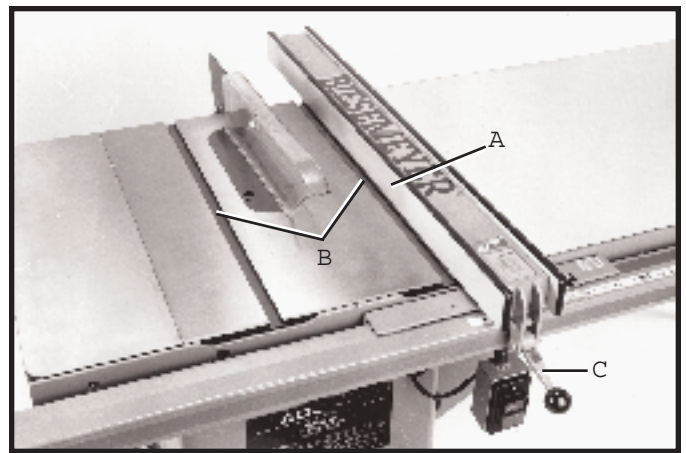

Fig. 27

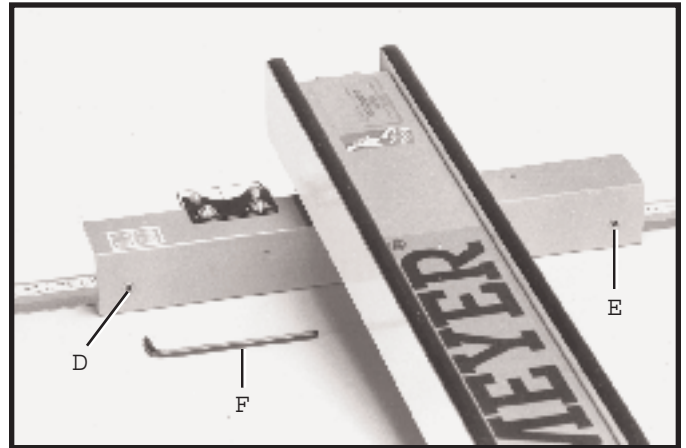

Fig. 28

ADJUSTING CLAMPING ACTION OF FENCE LOCKING HANDLE

When the fence locking handle (A) is pushed to the down position, as shown in Fig. 29, the fence assembly (B) should be completely clamped to the guide tube (C). If the fence assembly (B) is not completely clamped to the guide tube (C) when the handle (A) is pushed down, as shown in Fig. 29, lift up handle (A) and raise fence assembly (B) up off the guide tube (C). Slightly tighten the two adjusting screws (D) and (E) Fig. 30, using the 3/16 allen wrench (F) not supplied. Adjusting screws (D) and (E) Fig. 30, should be tightened an equal amount. Replace fence onto the guide tube and re-check to see if the fence assembly (B) Fig. 29, is completely tightened to the guide tube (C) with the locking handle (A) pushed down. Adjust further if necessary. **IMPORTANT: AFTER ADJUSTING THE CLAMPING ACTION OF THE FENCE LOCKING HANDLE, CHECK TO SEE IF THE FENCE IS PARALLEL TO THE MITER GAGE SLOT AND ADJUST IF NECESSARY.**

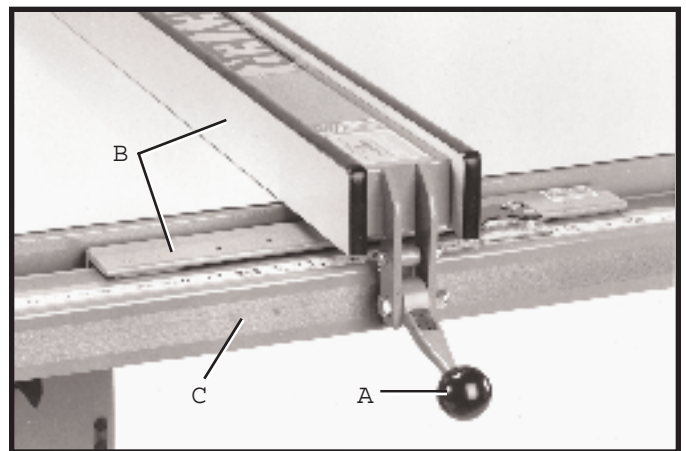

Fig. 29

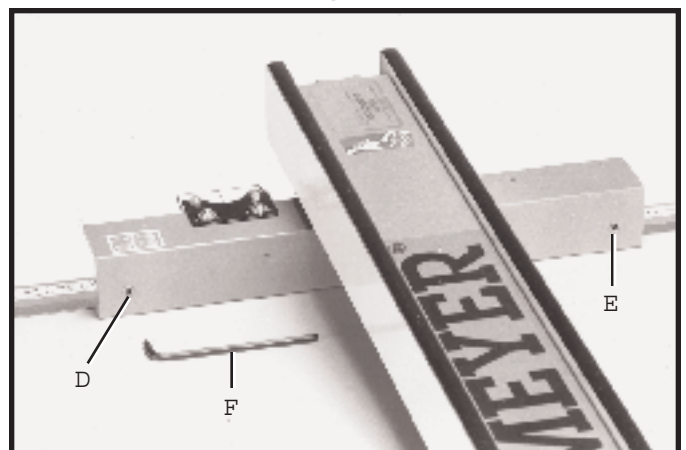

Fig. 30

LUBRICATION

1. Apply paste wax to fence and guide tube sliding surfaces weekly. Also, saw table and extension table surface should be waxed often.
2. Apply grease to cam lock (A) Fig. 31, and cam foot (B) occasionally to prevent wear.

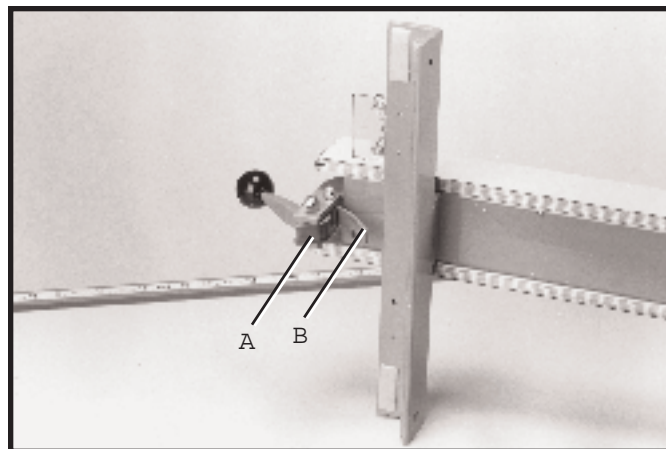

Fig. 31

PARTS, SERVICE OR WARRANTY ASSISTANCE

To obtain additional information regarding this product or to obtain parts, service or warranty assistance, please call or fax the following toll free Hotline number. Highly qualified and experienced Customer Service Representatives are standing by to assist you on weekdays from 7:00 AM to 5:00 PM Mountain Standard Time.

Biesemeyer^{fi}

a subsidiary of Delta Woodworking Machinery
216 South Alma School Rd., Suite 3
Mesa, AZ 85210

Phone:

(602) 835-9300

Hotline:

(800) 782-1831

Fax:

(602) 834-8515



Two Year Limited Warranty

Delta Machinery

Delta will repair or replace, at its expense and at its option, any Delta machine, machine part, or machine accessory which in normal use has proven to be defective in workmanship or material, provided that the customer notifies his supplying distributor of the alleged defect within two years from the date of delivery to him, of the product and provides Delta Machinery with reasonable opportunity to verify the defect by inspection. Delta Machinery may require that electric motors be returned prepaid to the supplying distributor or authorized service center for inspection and repair or replacement. Delta Machinery will not be responsible for any asserted defect which has resulted from misuse, abuse or repair or alteration made or specifically authorized by anyone other than an authorized Delta service facility or representative. Under no circumstances will Delta Machinery be liable for incidental or consequential damages resulting from defective products. This warranty is Delta Machinery's sole warranty and sets forth the customer's exclusive remedy, with respect to defective products; all other warranties, express or implied, whether of merchantability, fitness for purpose, or otherwise, are expressly disclaimed by Delta.

Free Manuals Download Website

<http://myh66.com>

<http://usermanuals.us>

<http://www.somanuals.com>

<http://www.4manuals.cc>

<http://www.manual-lib.com>

<http://www.404manual.com>

<http://www.luxmanual.com>

<http://aubethermostatmanual.com>

Golf course search by state

<http://golfingnear.com>

Email search by domain

<http://emailbydomain.com>

Auto manuals search

<http://auto.somanuals.com>

TV manuals search

<http://tv.somanuals.com>