

# Limited Edition 10" Contractor's Saw

with 30" Unifence®  
(Model 36-426)

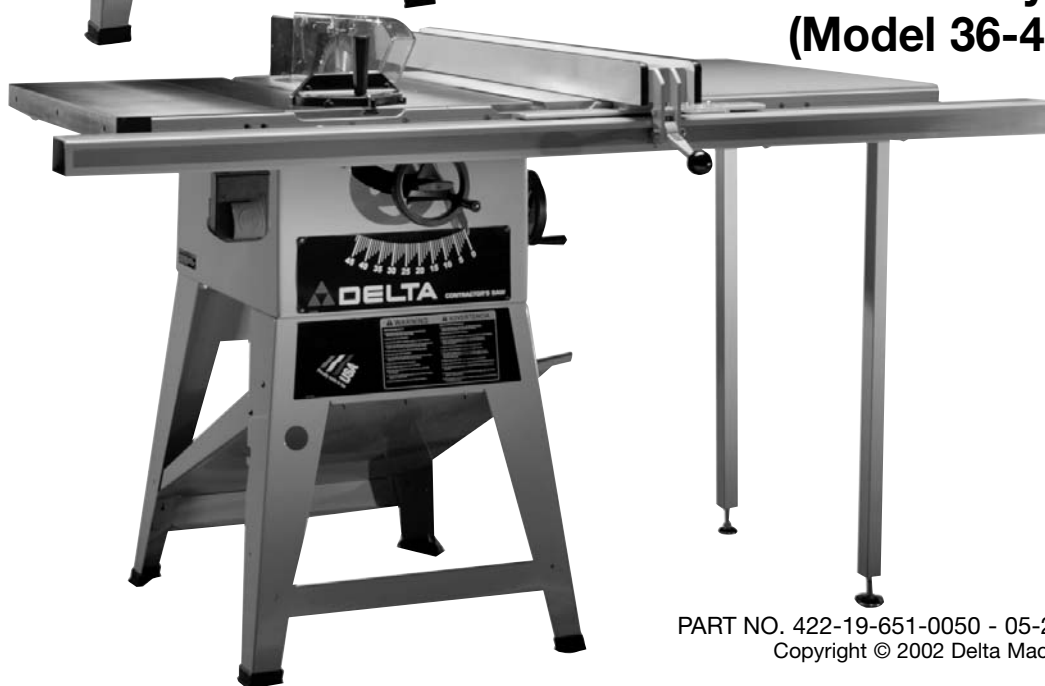

with 30" Biesemeyer®  
(Model 36-431)



PART NO. 422-19-651-0050 - 05-28-02  
Copyright © 2002 Delta Machinery



# DELTA

To learn more about DELTA MACHINERY  
visit our website at: [www.deltamachinery.com](http://www.deltamachinery.com).

For Parts, Service, Warranty or other Assistance,

please call **1-800-223-7278** (In Canada call **1-800-463-3582**).

# GENERAL SAFETY RULES

Woodworking can be dangerous if safe and proper operating procedures are not followed. As with all machinery, there are certain hazards involved with the operation of the product. Using the machine with respect and caution will considerably lessen the possibility of personal injury. However, if normal safety precautions are overlooked or ignored, personal injury to the operator may result. Safety equipment such as guards, push sticks, hold-downs, featherboards, goggles, dust masks and hearing protection can reduce your potential for injury. But even the best guard won't make up for poor judgment, carelessness or inattention. Always use common sense and exercise caution in the workshop. If a procedure feels dangerous, don't try it. Figure out an alternative procedure that feels safer. **REMEMBER:** Your personal safety is your responsibility.

This machine was designed for certain applications only. Delta Machinery strongly recommends that this machine not be modified and/or used for any application other than that for which it was designed. If you have any questions relative to a particular application, **DO NOT** use the machine until you have first contacted Delta to determine if it can or should be performed on the product.

## Technical Service Manager

Delta Machinery  
4825 Highway 45 North  
Jackson, TN 38305

(IN CANADA: 505 SOUTHGATE DRIVE, GUELPH, ONTARIO N1H 6M7)

## **WARNING: FAILURE TO FOLLOW THESE RULES MAY RESULT IN SERIOUS PERSONAL INJURY**

1. **FOR YOUR OWN SAFETY, READ INSTRUCTION MANUAL BEFORE OPERATING THE MACHINE.** Learn the machine's application and limitations as well as the specific hazards peculiar to it.

2. **KEEP GUARDS IN PLACE** and in working order.

3. **ALWAYS WEAR EYE PROTECTION.** Wear safety glasses. Everyday eyeglasses only have impact resistant lenses; they are not safety glasses. Also use face or dust mask if cutting operation is dusty. These safety glasses must conform to ANSI Z87.1 requirements. **NOTE:** Approved glasses have Z87 printed or stamped on them.

4. **REMOVE ADJUSTING KEYS AND WRENCHES.** Form habit of checking to see that keys and adjusting wrenches are removed from machine before turning it "on".

5. **KEEP WORK AREA CLEAN.** Cluttered areas and benches invite accidents.

6. **DON'T USE IN DANGEROUS ENVIRONMENT.** Don't use power tools in damp or wet locations, or expose them to rain. Keep work area well-lighted.

7. **KEEP CHILDREN AND VISITORS AWAY.** All children and visitors should be kept a safe distance from work area.

8. **MAKE WORKSHOP CHILDPROOF** – with padlocks, master switches, or by removing starter keys.

9. **DON'T FORCE MACHINE.** It will do the job better and be safer at the rate for which it was designed.

10. **USE RIGHT MACHINE.** Don't force machine or attachment to do a job for which it was not designed.

11. **WEAR PROPER APPAREL.** No loose clothing, gloves, neckties, rings, bracelets, or other jewelry to get caught in moving parts. Nonslip footwear is recommended. Wear protective hair covering to contain long hair.

12. **SECURE WORK.** Use clamps or a vise to hold work when practical. It's safer than using your hand and frees both hands to operate machine.

13. **DON'T OVERREACH.** Keep proper footing and balance at all times.

14. **MAINTAIN TOOLS IN TOP CONDITION.** Keep tools sharp and clean for best and safest performance. Follow instructions for lubricating and changing accessories.

15. **DISCONNECT TOOLS** before servicing and when changing accessories such as blades, bits, cutters, etc.

16. **USE RECOMMENDED ACCESSORIES.** The use of accessories and attachments not recommended by Delta may cause hazards or risk of injury to persons.

17. **REDUCE THE RISK OF UNINTENTIONAL STARTING.** Make sure switch is in "OFF" position before plugging in power cord. In the event of a power failure, move switch to the "OFF" position.

18. **NEVER STAND ON MACHINE.** Serious injury could occur if the machine is tipped or if the cutting machine is accidentally contacted.

19. **CHECK DAMAGED PARTS.** Before further use of the machine, a guard or other part that is damaged should be carefully checked to ensure that it will operate properly and perform its intended function – check for alignment of moving parts, binding of moving parts, breakage of parts, mounting, and any other conditions that may affect its operation. A guard or other part that is damaged should be properly repaired or replaced.

20. **DIRECTION OF FEED.** Feed work into a blade or cutter against the direction of rotation of the blade or cutter only.

21. **NEVER LEAVE MACHINE RUNNING UNATTENDED. TURN POWER OFF.** Don't leave machine until it comes to a complete stop.

22. **STAY ALERT, WATCH WHAT YOU ARE DOING, AND USE COMMON SENSE WHEN OPERATING A POWER MACHINE. DO NOT USE MACHINE WHILE TIRED OR UNDER THE INFLUENCE OF DRUGS, ALCOHOL, OR MEDICATION.** A moment of inattention while operating power tools may result in serious personal injury.

23. **MAKE SURE MACHINE IS DISCONNECTED FROM POWER SUPPLY** while motor is being mounted, connected or reconnected.

24. **THE DUST GENERATED** by certain woods and wood products can be injurious to your health. Always operate machinery in well ventilated areas and provide for proper dust removal. Use wood dust collection systems whenever possible.

25.  **WARNING: SOME DUST CREATED BY POWER SANDING, SAWING, GRINDING, DRILLING, AND OTHER CONSTRUCTION ACTIVITIES** contains chemicals known to cause cancer, birth defects or other reproductive harm. Some examples of these chemicals are:

- lead from lead-based paints,
  - crystalline silica from bricks and cement and other masonry products, and
  - arsenic and chromium from chemically-treated lumber.
- Your risk from these exposures varies, depending on how often you do this type of work. To reduce your exposure to these chemicals: work in a well ventilated area, and work with approved safety equipment, such as those dust masks that are specially designed to filter out microscopic particles.

**SAVE THESE INSTRUCTIONS.**

**Refer to them often and use them to instruct others.**

# ADDITIONAL SAFETY RULES FOR TABLE SAWS



**WARNING: FAILURE TO FOLLOW THESE RULES MAY RESULT IN SERIOUS PERSONAL INJURY.**

1. **DO NOT OPERATE THIS MACHINE** until it is **assembled** and **installed** according to the instructions.
2. **OBTAIN ADVICE FROM YOUR SUPERVISOR, instructor, or another qualified person** if you are not familiar with the operation of this machine.
3. **FOLLOW ALL WIRING CODES** and recommended electrical connections.
4. **USE THE GUARDS WHENEVER POSSIBLE.** Check to see that they are in place, secured, and working correctly.
5. **AVOID KICKBACK by:**
  - A. keeping blade sharp and free of rust and pitch.
  - B. keeping rip fence parallel to the saw blade.
  - C. using saw blade guard and spreader for every possible operation, including all through sawing.
  - D. pushing the workpiece past the saw blade prior to release.
  - E. never ripping a workpiece that is twisted or warped, or does not have a straight edge to guide along the fence.
  - F. using featherboards when the anti-kickback device cannot be used.
  - G. never sawing a large workpiece that cannot be controlled.
  - H. never using the fence as a guide when crosscutting.
  - I. never sawing a workpiece with loose knots or other flaws.
6. **ALWAYS USE GUARDS, SPLITTER, AND ANTI-KICKBACK FINGERS** except when otherwise directed in the manual.
7. **REMOVE CUT-OFF PIECES AND SCRAPS** from the table before starting the saw. The vibration of the machine may cause them to move into the saw blade and be thrown out. After cutting, turn the machine off. When the blade has **come to a complete stop, remove all debris.**
8. **NEVER START THE MACHINE** with the workpiece against the blade.
9. **HOLD THE WORKPIECE FIRMLY** against the miter gauge or fence.
10. **NEVER** run the workpiece between the fence and a moulding cutterhead.
11. **NEVER** perform “free-hand” operations. Use either the fence or miter gauge to position and guide the workpiece.
12. **USE PUSH STICK(S)** for ripping a narrow workpiece.
13. **AVOID AWKWARD OPERATIONS AND HAND POSITIONS** where a sudden slip could cause a hand to move into the blade.
14. **KEEP ARMS, HANDS, AND FINGERS** away from the blade.
15. **NEVER** have any part of your body in line with the path of the saw blade.
16. **NEVER REACH AROUND** or over the saw blade.
17. **NEVER** attempt to free a stalled saw blade without first turning the machine “OFF”.
18. **PROPERLY SUPPORT LONG OR WIDE** workpieces.
19. **NEVER PERFORM LAYOUT**, assembly or set-up work on the table/work area when the machine is running.
20. **TURN THE MACHINE “OFF” AND DISCONNECT THE MACHINE** from the power source before installing or removing accessories, before adjusting or changing set-ups, or when making repairs.
21. **TURN THE MACHINE “OFF”**, disconnect the machine from the power source, and clean the table/work area before leaving the machine. **LOCK THE SWITCH IN THE “OFF” POSITION** to prevent unauthorized use.
22. **ADDITIONAL INFORMATION** regarding the safe and proper operation of this machine is available from the Power Machine Institute, 1300 Summer Avenue, Cleveland, OH 44115-2851. Information is also available from the National Safety Council, 1121 Spring Lake Drive, Itasca, IL 60143-3201. Please refer to the American National Standards Institute ANSI O1.1 Safety Requirements for Woodworking Machines and the U.S. Department of Labor OSHA 1910.213 Regulations.

**SAVE THESE INSTRUCTIONS.  
Refer to them often  
and use them to instruct others.**

# POWER CONNECTIONS

A separate electrical circuit should be used for your tools. This circuit should not be less than #12 wire and should be protected with a time lag fuse. If an extension cord is used, use only 3-wire extension cords which have 3-prong grounding type plugs and matching receptacle which will accept the machine's plug. Before connecting the motor to the power line, make sure the switch is in the "OFF" position and be sure that the electric current is of the same characteristics as indicated on the machine. All line connections should make good contact. Running on low voltage will damage the motor.

 **WARNING: DO NOT EXPOSE THE MACHINE TO RAIN OR OPERATE THE MACHINE IN DAMP LOCATIONS.**

## GROUNDING INSTRUCTIONS

 **WARNING: THIS MACHINE MUST BE GROUNDED WHILE IN USE TO PROTECT THE OPERATOR FROM ELECTRIC SHOCK.**

1. All grounded, cord-connected tools:

In the event of a malfunction or breakdown, grounding provides a path of least resistance for electric current to reduce the risk of electric shock. This tool is equipped with an electric cord having an equipment-grounding conductor and a grounding plug. The plug must be plugged into a matching outlet that is properly installed and grounded in accordance with all local codes and ordinances.

Do not modify the plug provided - if it will not fit the outlet, have the proper outlet installed by a qualified electrician.

Improper connection of the equipment-grounding conductor can result in risk of electric shock. The conductor with insulation having an outer surface that is green with or without yellow stripes is the equipment-grounding conductor. If repair or replacement of the electric cord or plug is necessary, do not connect the equipment-grounding conductor to a live terminal.

Check with a qualified electrician or service personnel if the grounding instructions are not completely understood, or if in doubt as to whether the tool is properly grounded.

Use only 3-wire extension cords that have 3-prong grounding type plugs and matching 3-conductor receptacles that accept the tool's plug, as shown in Fig. A. Repair or replace damaged or worn cord immediately.

2. Grounded, cord-connected tools intended for use on a supply circuit having a nominal rating less than 150 volts:

If the tool is intended for use on a circuit that has an outlet that looks like the one illustrated in Fig. A. The tool will have a grounding plug that looks like the plug illustrated in Fig. A.

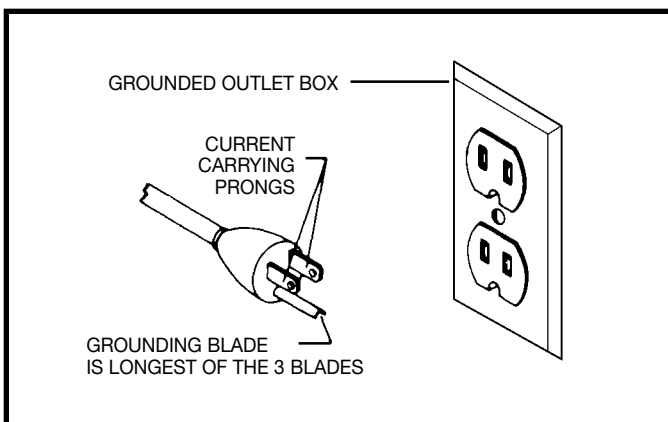



Fig. A

A temporary adapter, which looks like the adapter illustrated in Fig. B, may be used to connect this plug to a matching 2-conductor receptacle as shown in Fig. B if a properly grounded outlet is not available. The temporary adapter should be used only until a properly grounded outlet can be installed by a qualified electrician. The green-colored rigid ear, lug, and the like, extending from the adapter must be connected to a permanent ground such as a properly grounded outlet box. Whenever the adapter is used, it must be held in place with a metal screw.

**NOTE: In Canada, the use of a temporary adapter is not permitted by the Canadian Electric Code.**

3. Grounded, cord-connected tools intended for use on a supply circuit having a nominal rating between 150 - 250 volts, inclusive:

If the tool is intended for use on a circuit that has an outlet that looks like the one illustrated in Fig. C. The tool will have a grounding plug that looks like the plug illustrated in Fig. C. Make sure the tool is connected to an outlet having the same configuration as the plug. No adapter is available or should be used with this tool. If the tool must be reconnected for use on a different type of electric circuit, the reconnection should be made by qualified service personnel; and after reconnection, the tool should comply with all local codes and ordinances.

 **WARNING: IN ALL CASES, MAKE CERTAIN THE RECEPTACLE IN QUESTION IS PROPERLY GROUNDED. IF YOU ARE NOT SURE HAVE A QUALIFIED ELECTRICIAN CHECK THE RECEPTACLE.**

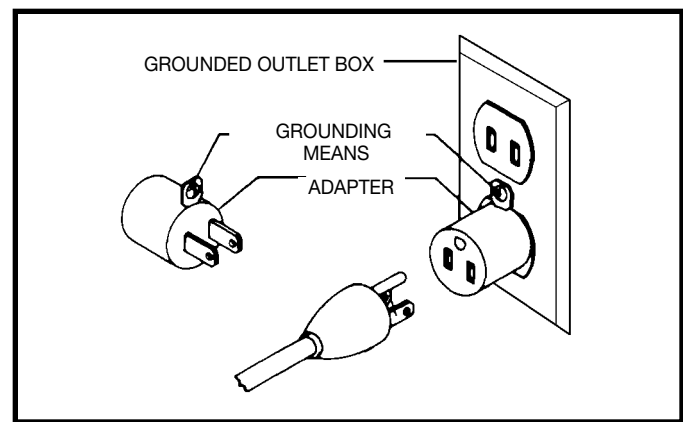

Fig. B

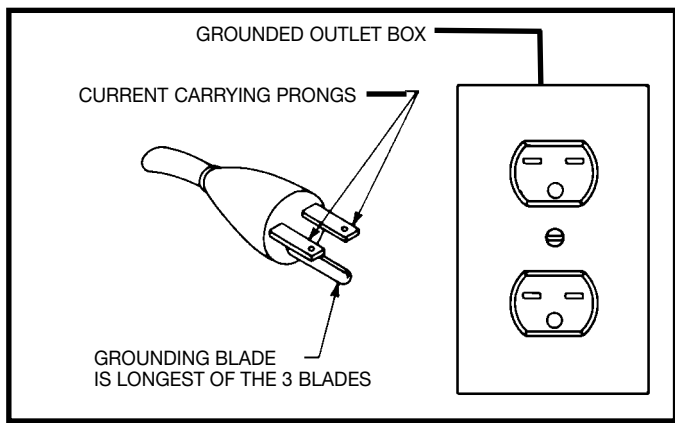

Fig. C

## EXTENSION CORDS

Use proper extension cords. Make sure your extension cord is in good condition and is a 3-wire extension cord which has a 3-prong grounding type plug and matching receptacle which will accept the machine's plug. When using an extension cord, be sure to use one heavy enough to carry the current of the machine. An undersized cord will cause a drop in line voltage, resulting in loss of power and overheating. Fig. D, shows the correct gauge to use depending on the cord length. If in doubt, use the next heavier gauge. The smaller the gauge number, the heavier the cord.

MINIMUM GAUGE EXTENSION CORD			
RECOMMENDED SIZES FOR USE WITH STATIONARY ELECTRIC TOOLS			
Ampere Rating	Volts	Total Length of Cord in Feet	Gauge of Extension Cord
0-6	120	up to 25	18 AWG
0-6	120	25-50	16 AWG
0-6	120	50-100	16 AWG
0-6	120	100-150	14 AWG
6-10	120	up to 25	18 AWG
6-10	120	25-50	16 AWG
6-10	120	50-100	14 AWG
6-10	120	100-150	12 AWG
10-12	120	up to 25	16 AWG
10-12	120	25-50	16 AWG
10-12	120	50-100	14 AWG
10-12	120	100-150	12 AWG
12-16	120	up to 25	14 AWG
12-16	120	25-50	12 AWG
12-16	120	GREATER THAN 50 FEET NOT RECOMMENDED	

Fig. D

MINIMUM GAUGE EXTENSION CORD			
RECOMMENDED SIZES FOR USE WITH STATIONARY ELECTRIC TOOLS			
Ampere Rating	Volts	Total Length of Cord in Feet	Gauge of Extension Cord
0-6	240	up to 50	18 AWG
0-6	240	50-100	16 AWG
0-6	240	100-200	16 AWG
0-6	240	200-300	14 AWG
6-10	240	up to 50	18 AWG
6-10	240	50-100	16 AWG
6-10	240	100-200	14 AWG
6-10	240	200-300	12 AWG
10-12	240	up to 50	16 AWG
10-12	240	50-100	16 AWG
10-12	240	100-200	14 AWG
10-12	240	200-300	12 AWG
12-16	240	up to 50	14 AWG
12-16	240	50-100	12 AWG
12-16	240	GREATER THAN 100 FEET NOT RECOMMENDED	

Fig. D

# OPERATING INSTRUCTIONS

## FOREWORD

Delta 10" Contractor's Saws are designed to give high quality performance with maximum depth of cut capacity up to 3-1/8" at 90° and 2-1/8" at 45°. Delta Model 36-426 includes a 30" Unifence Fence System with T-Slot rail and Model 36-431 includes a 30" Biesemeyer T-Square Home Shop Fence System. These Delta Models come equipped with basic machine, sturdy steel stand, integral dust chute, patented Auto-Set T-Slot miter gage, heavy duty motor, large on/off paddle switch, extension wing, cast table, convenient up-front blade raising and tilting controls, and 10" carbide blade.

**NOTICE: THE MANUAL COVER PHOTO ILLUSTRATES THE CURRENT PRODUCTION MODEL. ALL OTHER ILLUSTRATIONS ARE REPRESENTATIVE ONLY AND MAY NOT DEPICT THE ACTUAL COLOR, LABELING OR ACCESSORIES AND MAY BE INTENDED TO ILLUSTRATE TECHNIQUE ONLY.**



# UNPACKING AND CLEANING

Carefully unpack the table saw and all loose items from the shipping containers. Remove the protective coating from the machined surfaces of the saw. This coating may be removed with a soft cloth moistened with kerosene (do not use acetone, gasoline or lacquer thinner for this purpose). After cleaning, cover the unpainted surfaces with a good quality household floor paste wax. Fig. 2, illustrates the components of the table saw. Fig. 3, illustrates the components of the saw stand. Fig. 4, illustrates the components of the Unifence® Figs. 5, 6 and 7 illustrates the components of the Biesemeyer Fence.

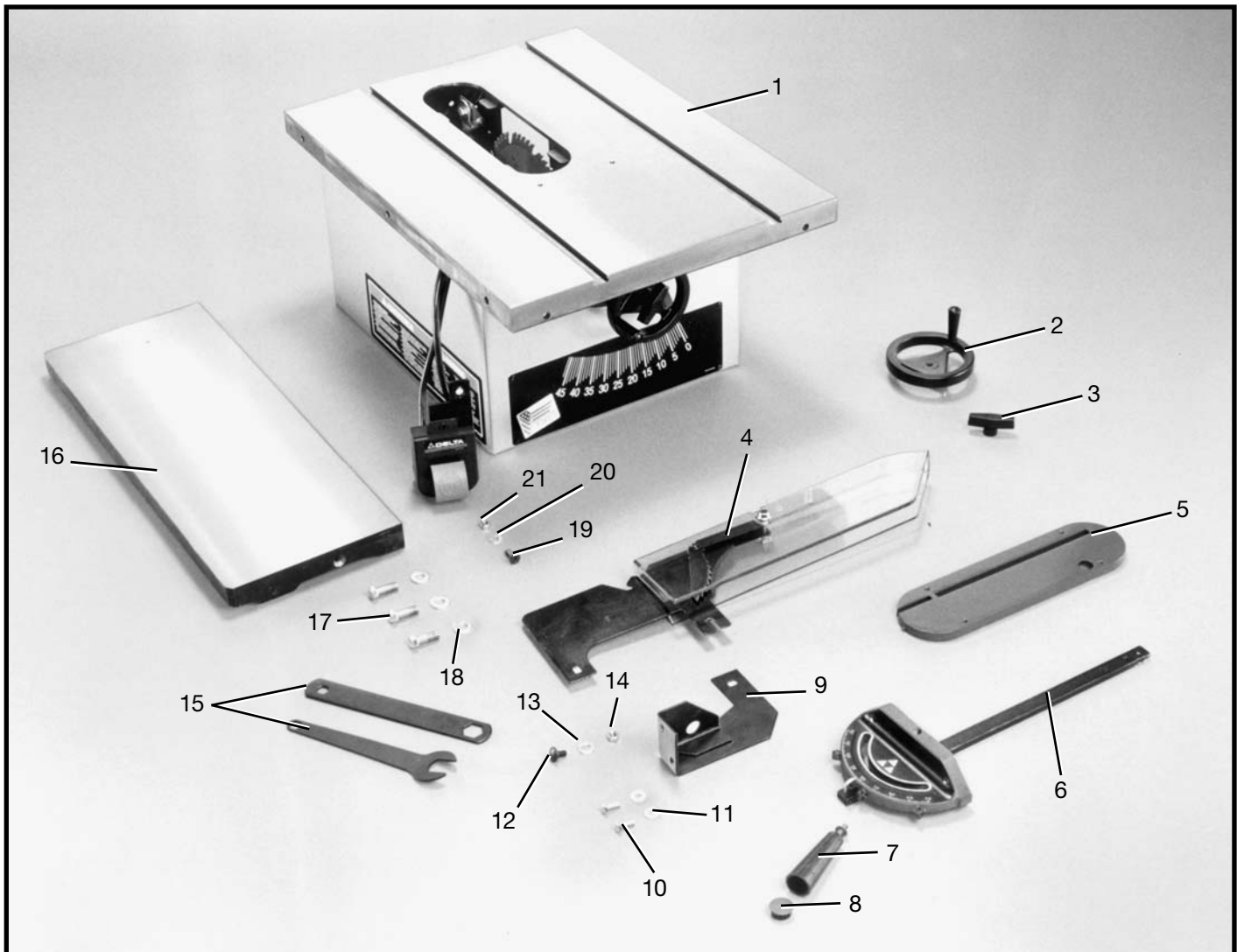

Fig. 2

- |                                       |   |
|---------------------------------------|---|
| 1. Contractor's Saw                   | 12. 5/16-18 x 5/8" Carriage Head Screw                                  |
| 2. Blade Tilting Handwheel            | 13. 5/16" Flat Washer   |
| 3. Handwheel Lock Knob                | 14. 5/16-18 Hex Nut   |
| 4. Blade Guard and Splitter Assembly  | 15. Arbor Wrenches (2)  |
| 5. Table Insert                       | 16. Extension Table   |
| 6. Miter Gage                         | 17. 7/16-20 x 1-3/4" Hex Head Screws for assembling extension table (3) |
| 7. Miter Gage Handle                  | 18. Flat Washers for assembling extension wing (3)                      |
| 8. Miter Gage Handle Cap              | 19. 1/4-20 x 3/4" Flat head Screw                                       |
| 9. Splitter Mounting Bracket          | 20. Flat Washer   |
| 10. 1/4-20 x 3/4" Hex Head Screws (2) | 21. Hex Nut   |
| 11. 1/4" Flat Washers (2)             |   |

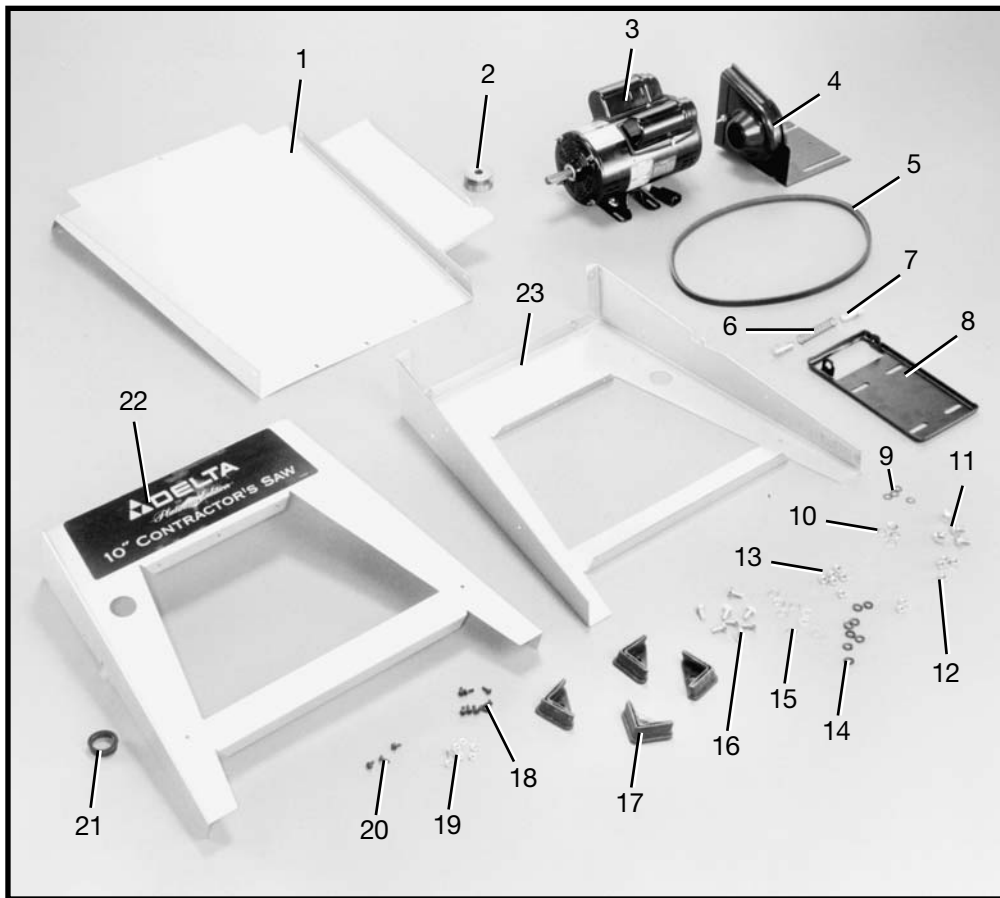

Fig. 3

### UNIFENCE T-SLOT RAIL FENCE SYSTEM

1. Combination Dust Chute/Support Panel
2. Motor Pulley
3. Motor
4. Pulley Guard
5. Drive Belt
6. Spring
7. Pins (2) for Mounting Motor
8. Motor Mounting Plate
9. Lockwashers (4)
10. Flat Washers (4)
11. 5/16-18 x 3/4" Carriage Head Screws (4)
12. 5/16" Hex Nuts (4)
13. 5/16" Hex Nuts (8)
14. 5/16" Lockwashers (8)
15. 5/16" Flat Washers
16. 5/16-18 x 5/8" Hex Head Screws (8)
17. Rubber Feet (4)
18. #10-32 x 12 Screws (8)
19. #10 Keps Nuts (8)
20. #10-1/2" Sheet Metal Screws (3)
21. Grommet
22. Front Leg Panel
23. Rear Leg Panel

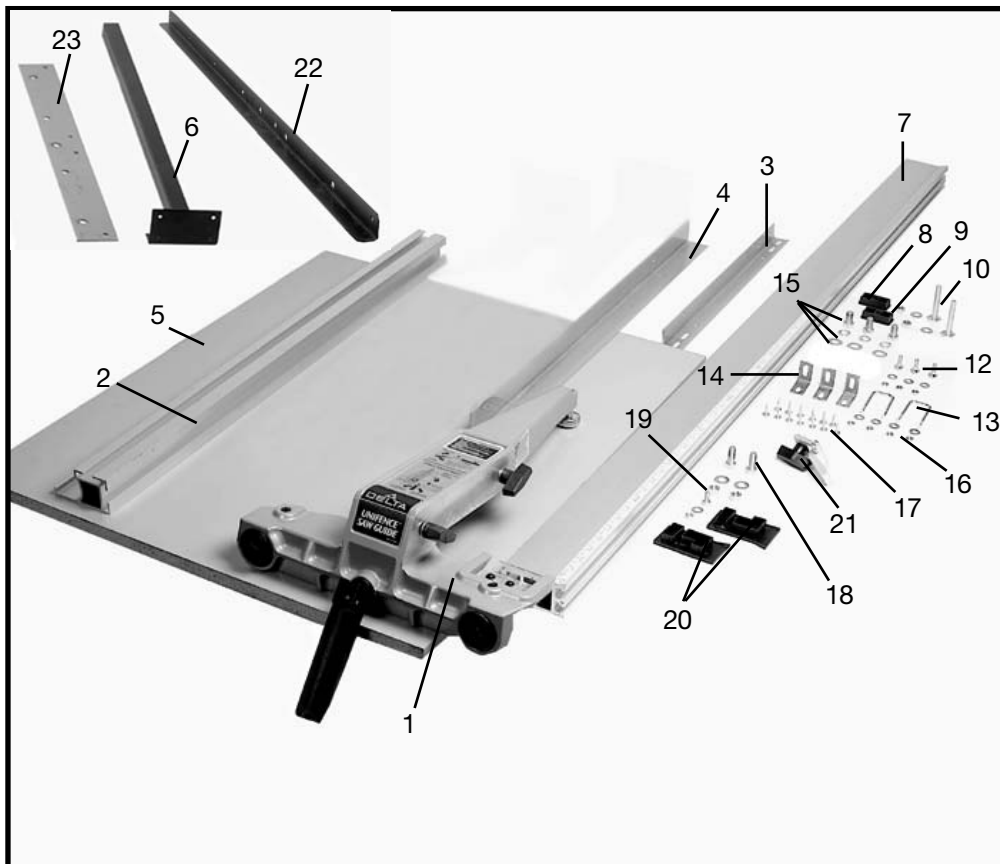

Fig. 4

1. Unifence Body
2. Fence
3. Shelf Support Bracket
4. Front Table Support
5. Table Board
6. Table Legs (2)
7. Front T-Slot Guide Rail
8. Leg Adapter Insert (2)
9. 3/8-16 Nut (2)
10. Leveling Screws (2)
12. 7/16-20 x 3/4" Hex Head Screws, Lockwashers, (3 ea.)
13. U-Bolts (2)
14. Angle Brackets (5)
15. 1/4-20 x 3/4" Carriage Head Screws, Flat Washers, and 1/4-20 Hex Nuts (5 ea.)
16. Flat Washers and 1/4-20 Hex Nuts for U-Bolts (4 ea.)
17. #8 x 3/4" Hex Washer Head Screws (14)
18. 3/8-16 x 1" Hex Head Bolts Flat Washers, and Hex Nuts (5 ea.)
19. 1/4-20 Hex Head Bolt, Flat Washer and Hex Nut (1 ea.)
20. Guide Rail End Caps (2 ea.) with Rail
21. Unifence Flip Stop Parts
22. Rear Guide Rail (1)
23. Table Adapter Plate (1)
24. Cursor (not shown)
25. 3/8-16 x 1-1/4" Hex Head Bolt, Flat Washer and Nut (1) (not shown)

# BIESEMEYER T-SQUARE FENCE SYSTEM

The T-Square® Commercial Fence System includes the fence assembly, front rail, rear rail, front guide tube and right extension table Model 78-943 for 30" capacity.

**IMPORTANT:** The T-Square® Fence System is designed to be used **ONLY** with a supporting extension table.

## UNPACKING

Carefully unpack the T-Square® fence system from the shipping carton(s). Figure(s) 5, 6 & 7 illustrates all the items supplied with the 78-914 fence system.

- 1 - Rear Rail
- 2 - Front Rail
- 3 - Guide Tube
- 4 - T-Square® Fence Assembly
- 5 - Template for aligning front rail to saw table

### for fastening guide tube to front rail

- 6 - 1/4-20 x 1/2" long hex head screws (7)
- 7 - Lock washers (7)

### for fastening rear rail to saw table and sheet metal extension wing if applicable

- 8 - 3/8-24 x 1-1/4" long hex head cap screws (2)
- 9 - 7/8" O.D. flat washers (2)
- 10 - Lock washers (2)
- 11 - 3/8-24 hex nuts (2)

### for fastening front rail to saw table

- 12 - 3/8-16 x 1-1/4" long flat head screws (2)
- 13 - 7/8" O.D. flat washers (2)
- 14 - Lock washers (2)
- 15 - 3/8-16 hex nuts (2)

### for fastening front and rear rails to right extension table

- 16 - 1/4-20 x 1-1/2" long flat head Phillips screws (8)
- 17 - 1-1/4" O.D. Flat Washers (6)
- 18 - 1/4-20 hex nuts (8)
- 19 - Extension Table

### for fastening extension table legs

- 20 - Legs (2)
- 21 - #8 x 5/8" long wood screws (8)
- 22 - 1/4-20 x 1-1/2" flat head Phillips screws (4)
- 23 - 1/4" flat washers (4)
- 24 - 1/4-20 hex nuts (4)

**NOTE: A common hardware package is used for several different models, therefore you may have leftover hardware.**



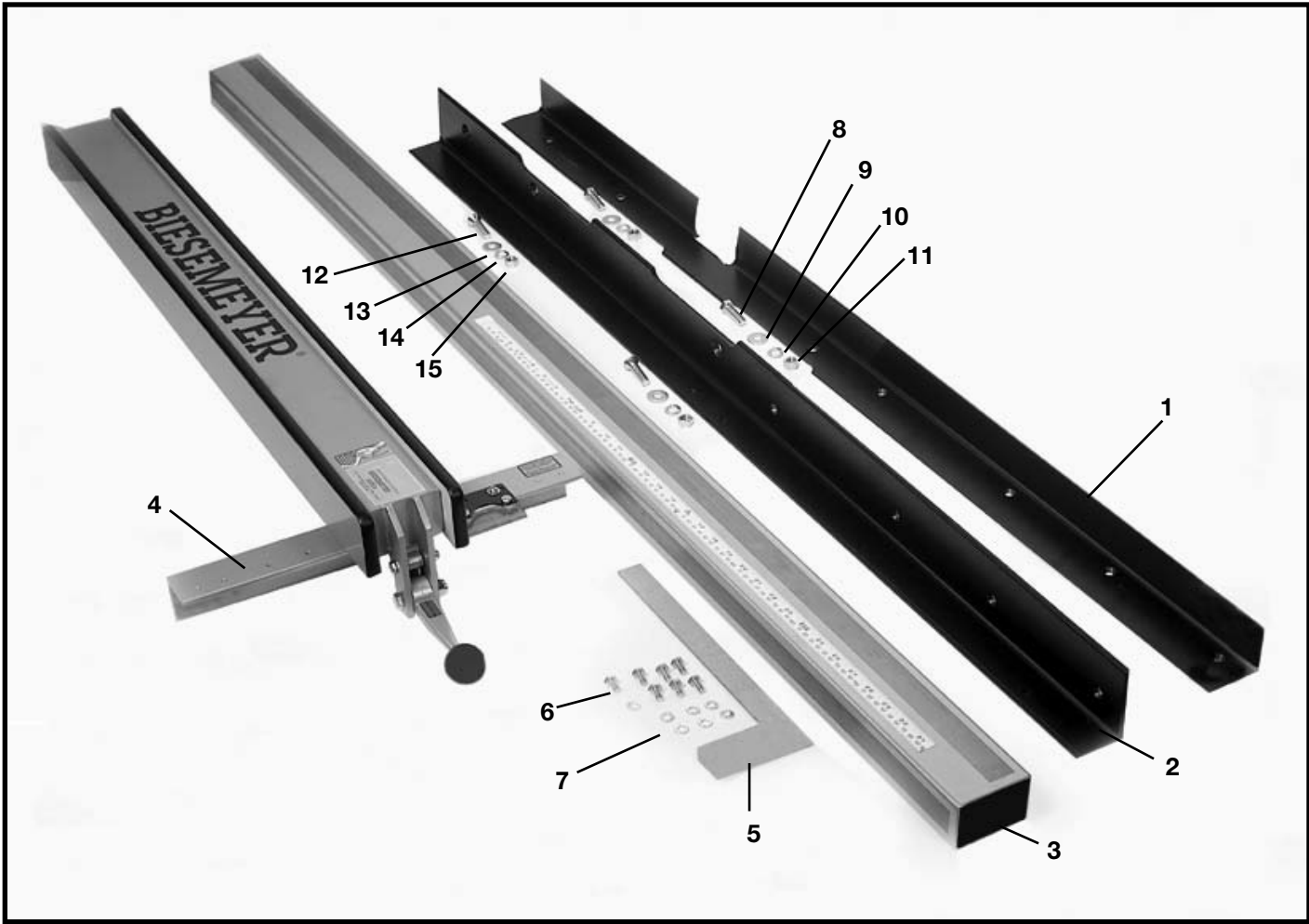

Fig. 5

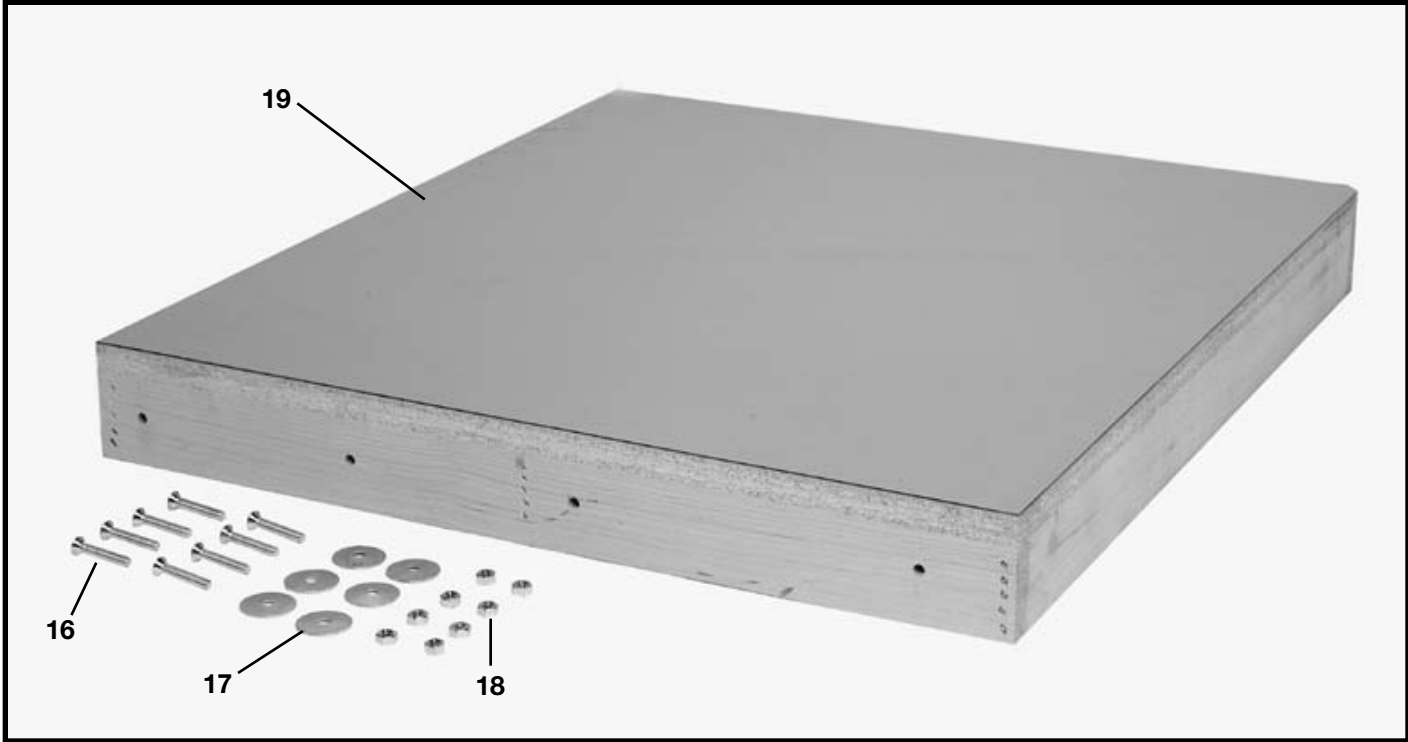

Fig. 6

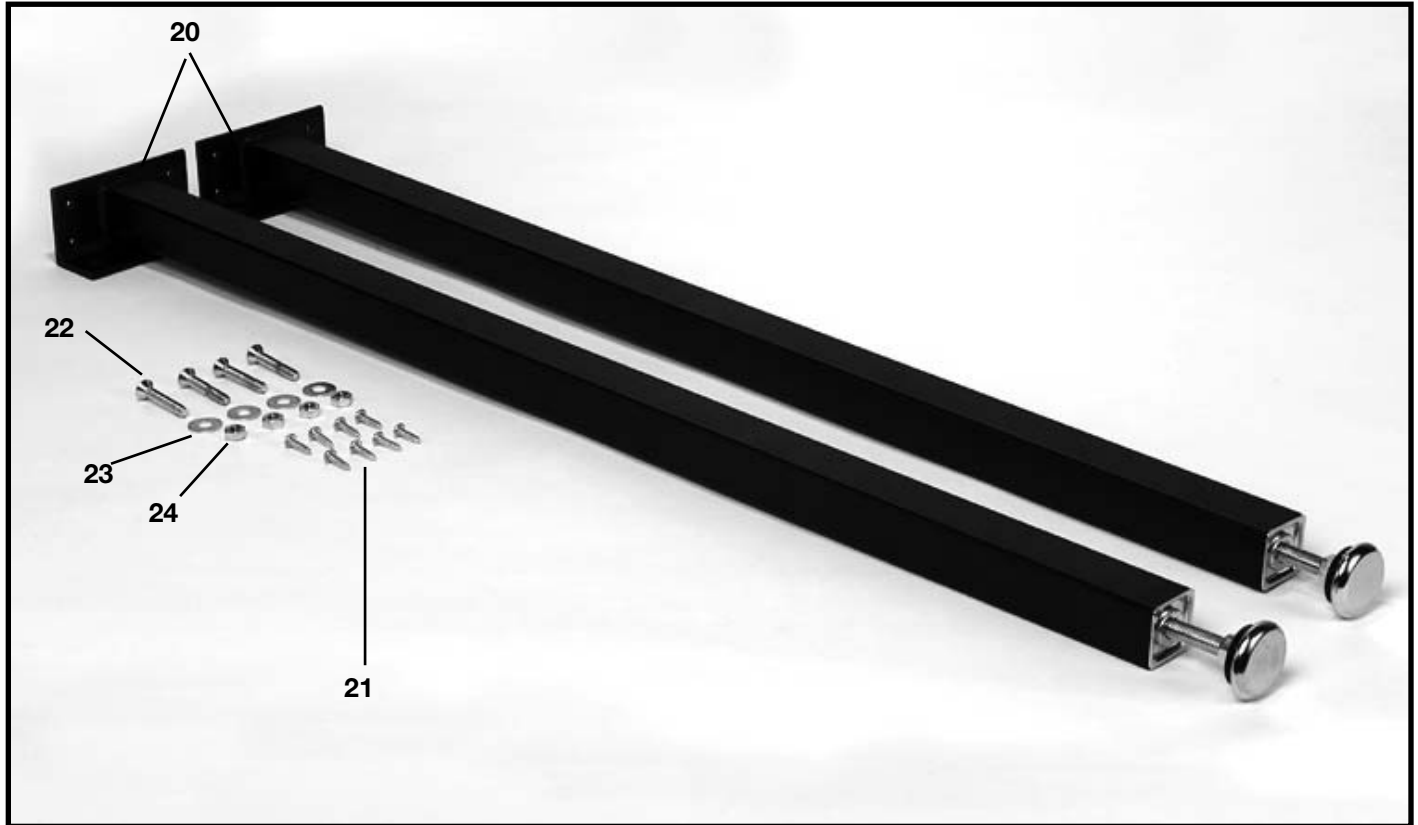

Fig. 7

# ASSEMBLY INSTRUCTIONS

**⚠ WARNING: MAKE SURE THE SAW IS SECURELY ATTACHED TO THE STAND BEFORE PERFORMING ANY CUTTING OPERATIONS. DO NOT OPERATE THIS MACHINE UNTIL YOU READ AND UNDERSTAND THE ENTIRE INSTRUCTION MANUAL.**

## ASSEMBLING SAW STAND

1. Assemble the dust chute and support panel (A) Fig. 8, to the inside of the front stand panel (B) with three #10 x 1/2" sheet metal screws (C).

2. Insert four #10-32 x 1/2" screws (D) Fig. 9 through support panel and dust chute. Install four #10-32 hex nuts (E) Fig. 9. **NOTE:** The front stand panel will have the saw identity labels facing you. Do not completely tighten the stand hardware at this time. Also, make certain the dust chute/support panel (A) Fig. 9, is located under the lip of front stand panel (B).

3. Assemble the other end of dust chute and support panel (A) Fig. 10, to rear stand panel (F) as shown with four #10-32 x 1/2" screws and #10-32 hex nuts, which are shown at (C). **NOTE:** Do not completely tighten stand hardware at this time.

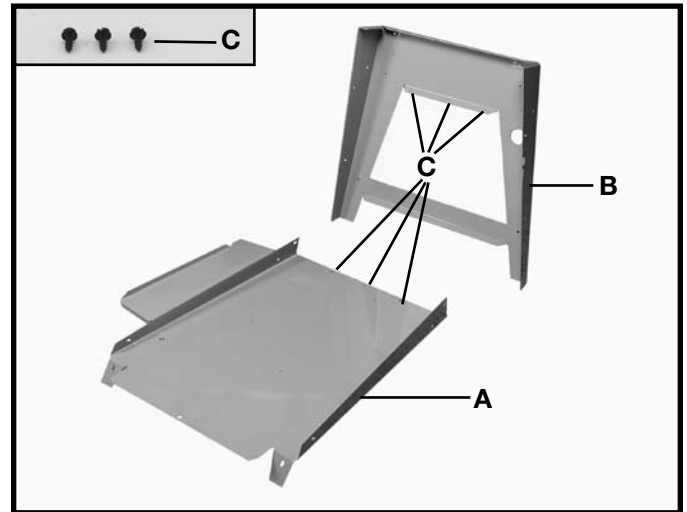

Fig. 8

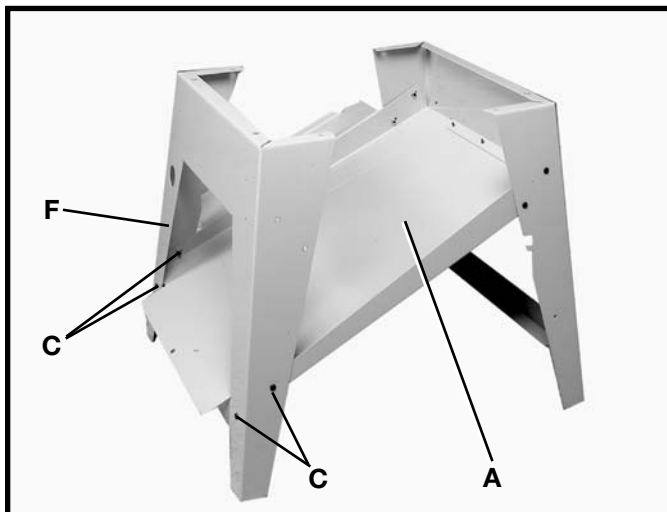

Fig. 10

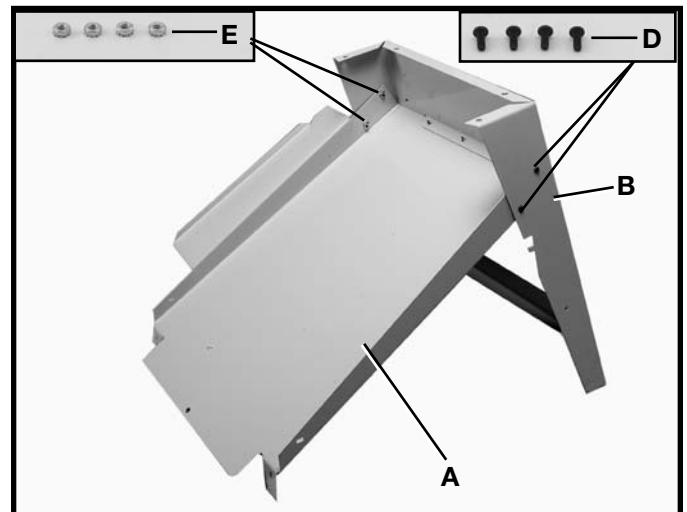

Fig. 9

## ASSEMBLING SAW TO STAND

1. Turn saw table face down on a piece of cardboard to protect the table surface. Place stand (B) Fig. 11, onto saw (A). Align eight holes in the stand (B) with mounting holes in the saw (A) and fasten with eight 5/16"-18 screws, flat washers, lockwashers, and hex nuts one of which is shown at (C) Fig. 11. Assemble flat washers onto screws, place screws through holes, assemble lockwashers then hex nuts finger tight. Do not completely tighten hardware at this time.

2. Install four rubber feet (D) Fig. 11, on the end of each stand leg (B).

3. Turn saw table face up.

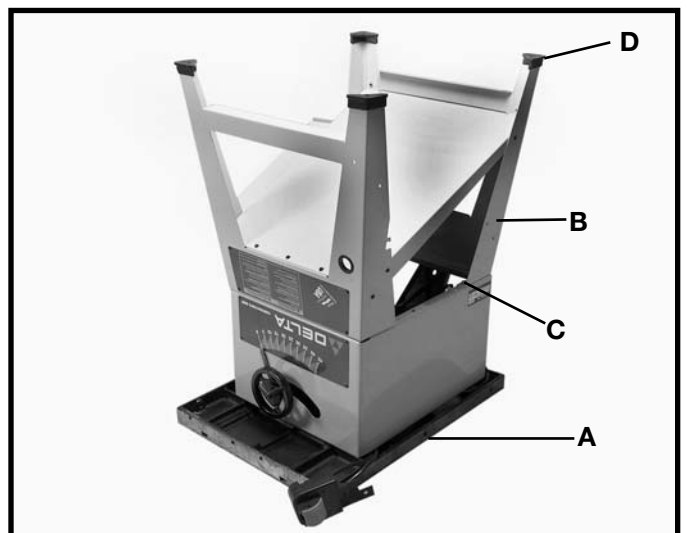

Fig. 11

## ASSEMBLING BLADE TILTING HANDWHEEL

1. Attach blade tilting handwheel (A) Fig. 13 to shaft (B). Make certain slot (C) in handwheel is engaged with roll pin (D) on the shaft.

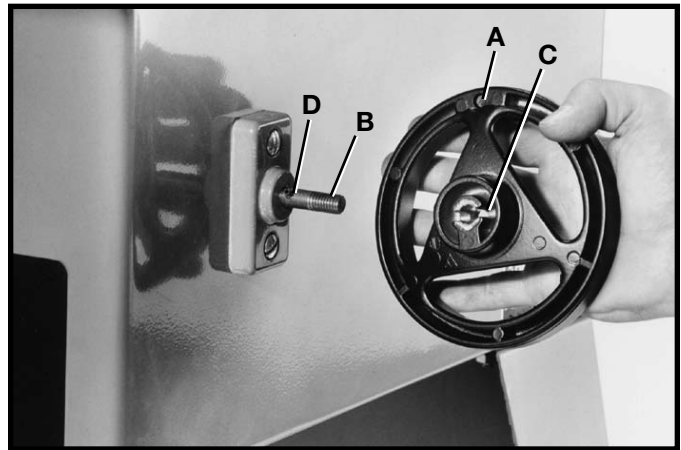

Fig. 13

2. Thread locking lever (E) Fig. 14, on shaft.
3. Fig. 14 illustrates the blade tilting handwheel (A) and locking lever (E) assembled to the saw.



Fig. 14

## MOTOR

The motor shipped with your saw is a 1-1/2 H.P. at 115 volts or 2 H.P. at 230 volts, Ball Bearing, Capacitor Start/Capacitor Run motor.

This motor has been especially selected to best supply power to your machine, and the relative safety of the machine is enhanced by its use. Use only this motor, as the use of other motors may be detrimental to the performance and safety of the saw.

## ASSEMBLING MOTOR TO MOTOR MOUNTING PLATE

**⚠ WARNING: WHEN ASSEMBLING THE MOTOR TO THE MOTOR MOUNTING PLATE, MAKE CERTAIN THE MACHINE IS DISCONNECTED FROM THE POWER SOURCE.**

1. Assemble the motor (A) to the motor mounting plate (B) as shown in Fig. 15, using four 5/16-18 carriage bolts, flat washers, star washers, and hex nuts (C). Assemble star washers on bolts, place bolts through holes, then assemble lockwashers and hex nuts.

**NOTE:** Do not completely tighten the hex nuts at this time.

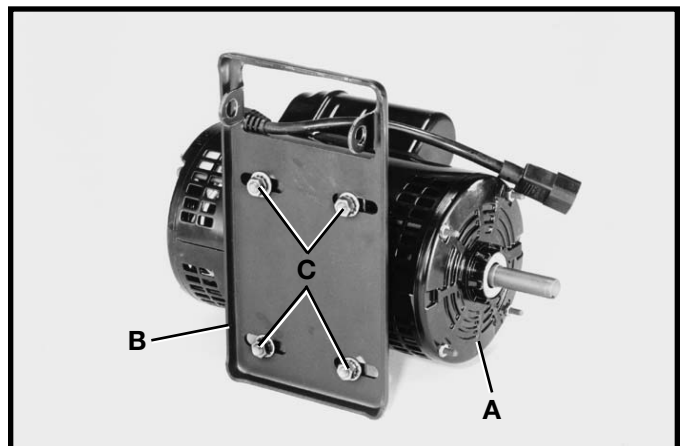

Fig. 15

# ASSEMBLING MOTOR AND MOTOR MOUNTING PLATE TO SAW

**⚠ WARNING: WHEN ASSEMBLING THE MOTOR AND MOTOR MOUNTING PLATE TO THE SAW, MAKE CERTAIN THE MACHINE IS DISCONNECTED FROM THE POWER SOURCE.**

1. Depress two pins (X) Fig. 16 and insert into holes (D) in each side of bracket (B). Pins are spring (Y) loaded from factory.

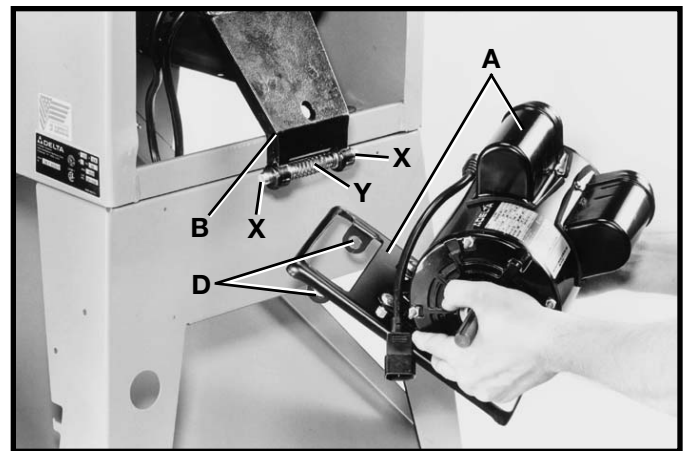

Fig. 16

2. Position motor and motor mounting plate (A) Fig. 17 below bracket (B) to allow bracket arm to slide through large opening in motor mounting plate (A).

3. Depress pins (C) Fig. 17, on both sides of bracket (B) and rotate motor mounting plate (A) until pins (C) are engaged in holes (D) Fig. 16, of motor mounting plate (A).

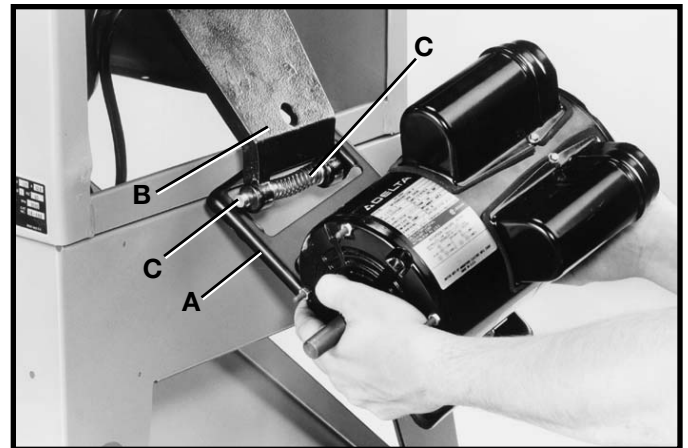

Fig. 17

4. Fig. 18 illustrates the motor and motor mounting plate assembled to the rear of the saw.



Fig. 18



# ASSEMBLING MOTOR PULLEY, BELT AND PULLEY GUARD, AND DRIVE BELT

**⚠ WARNING: WHEN ASSEMBLING MOTOR PULLEY, BELT AND PULLEY GUARD, AND DRIVE BELT, MAKE CERTAIN THE MOTOR IS DISCONNECTED FROM THE POWER SOURCE.**

1. Remove the motor shaft key that is taped to the motor.
2. Insert the key (A) Fig. 19 in the keyway on the motor shaft. Assemble the motor pulley (B) on the motor shaft with the hub of the pulley facing out. Tighten set screw (C).
3. Remove wing nut and external tooth lockwasher (D) Fig. 20, and outer cover (E) from belt and pulley guard (G).

4. Slide the belt and pulley guard bracket (G) Fig. 21 between the motor plate (M) and motor mounting plate (L), as shown.

5. Position belt and pulley guard bracket (G) Fig. 22, so that the motor pulley (B) is centered and through the hole in the belt and pulley guard bracket.
6. Use a straight edge to align the motor pulley with the arbor pulley. If necessary, adjust the motor pulley (B) Fig. 22 in or out on the motor shaft. Tighten the four hex nuts [refer back to (C) Fig. 15] that fasten the motor to the motor mounting plate.

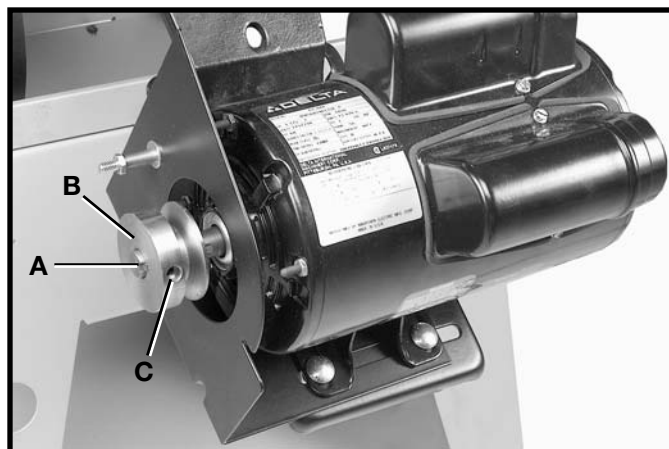

Fig. 19

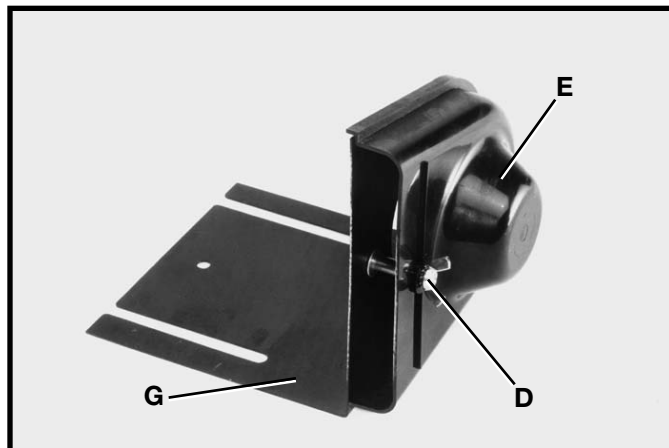

Fig. 20

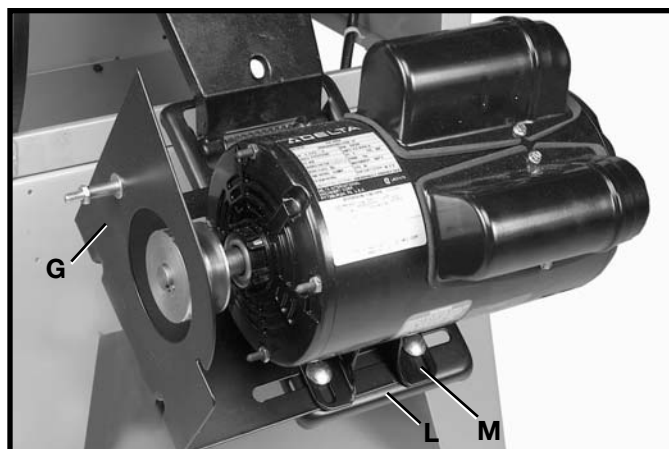

Fig. 21

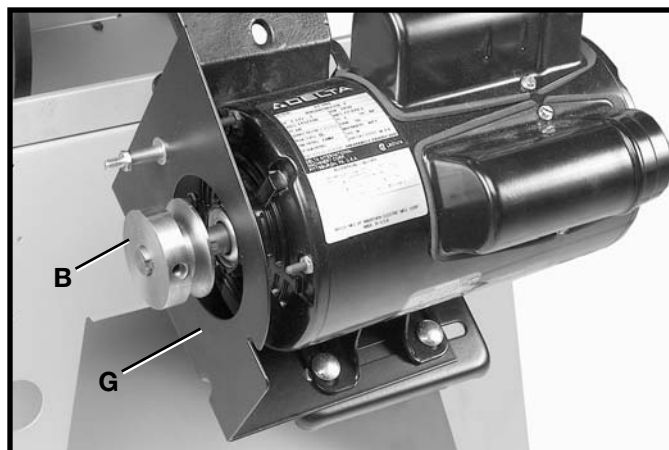

Fig. 22

7. Lift the motor and assemble the drive belt (H) Fig. 23 to the arbor pulley and motor pulley (B). The weight of the motor will provide the correct belt tension.

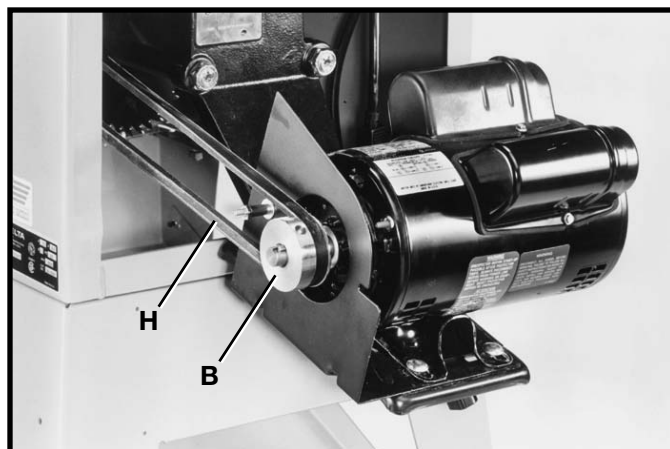

Fig. 23

8. **⚠ WARNING: IMMEDIATELY AFTER ASSEMBLING THE BELT, RAISE THE SAW BLADE TO ITS MAXIMUM HEIGHT AND TILT THE SAW BLADE TO 45 DEGREES. CHECK TO SEE IF THE MOTOR (J) FIG. 24 IS BELOW THE TOP OF THE TABLE SURFACE (K). IF THE MOTOR (J) IS ABOVE THE TOP OF THE TABLE SURFACE, MOVE THE MOTOR TO THE LEFT UNTIL THE END BELL (J) OF THE MOTOR IS BELOW THE TOP OF THE TABLE SURFACE. THEN RE-ALIGN THE MOTOR PULLEY TO THE ARBOR PULLEY.**

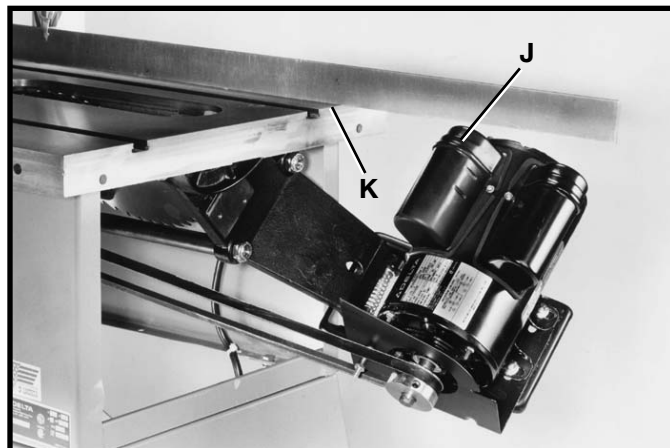

Fig. 24

9. Assemble the outer cover (E) Fig. 25, of the belt and pulley guard assembly, which was removed in **STEP 3**, and fasten with external tooth lockwasher and wing nut (D). **IMPORTANT:** Make certain the outer cover does not interfere with the drive belt and the motor pulley.



Fig. 25

## CONNECTING MOTOR CORD TO SWITCH ASSEMBLY

**⚠ WARNING: BEFORE CONNECTING MOTOR CORD TO THE SWITCH ASSEMBLY, MAKE CERTAIN THE MACHINE IS DISCONNECTED FROM THE POWER SOURCE.**

1. Insert the pronged motor plug (A) Fig. 26, into the female receptacle (B) of switch-to-motor cord (C).

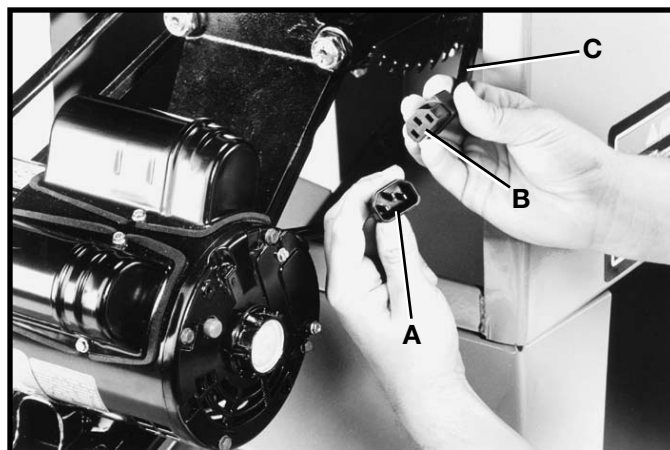

Fig. 26

2. Fig. 27, illustrates the motor cord connected to the switch assembly.

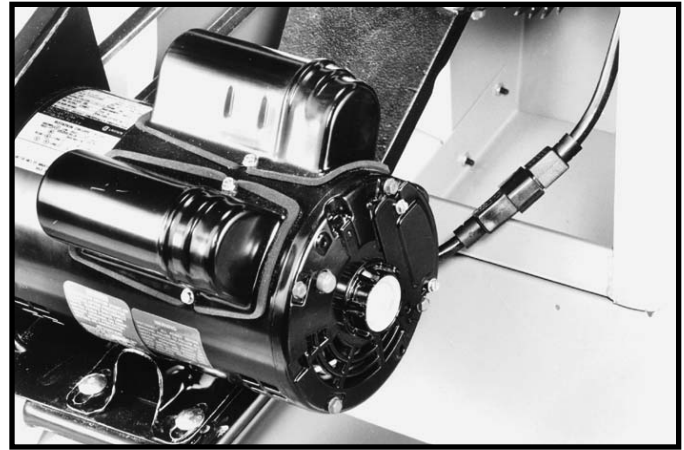

Fig. 27

## ASSEMBLING BLADE GUARD AND SPLITTER ASSEMBLY

**⚠ WARNING: DISCONNECT MACHINE FROM POWER SOURCE.**

1. Fasten the rear splitter mounting bracket (A) Fig. 28, to the rear trunnion using the two 1/4-20 x 3/4" hex head screws (B) and flat washers. Do not completely tighten the two screws (B) at this time.

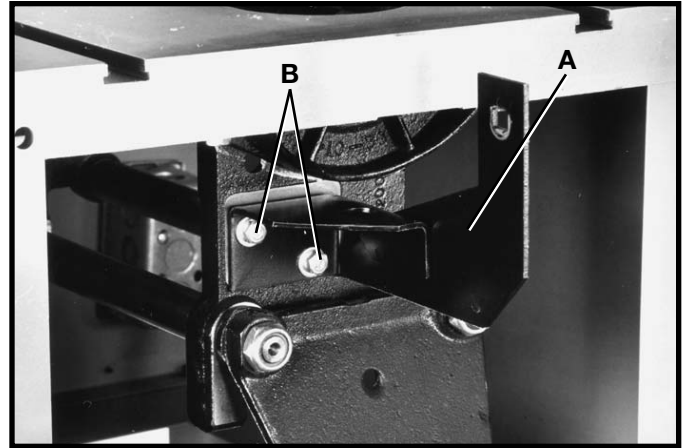

Fig. 28

2. Raise saw arbor to its highest position. With wrenches supplied, remove the saw blade from the saw. Refer to section "CHANGING THE SAW BLADE" of this manual.

3. Remove screw and large washer (C) Fig. 29, from the inside splitter mounting bracket.

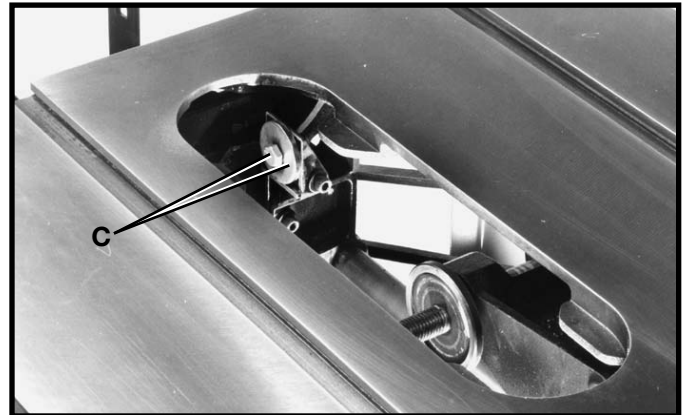

Fig. 29

4. Use a straight edge to check to see if the top and bottom of the inside splitter bracket (D) Fig. 30 is aligned with the inner arbor flange (E).

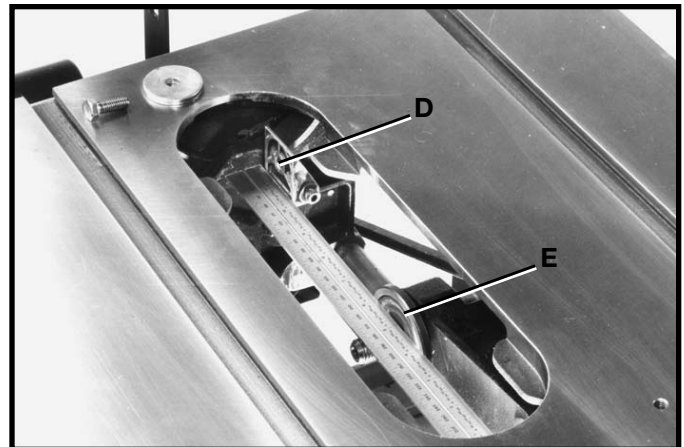

Fig. 30



5. If an alignment is necessary, loosen the two screws (F) Fig. 31, align bracket (D) with the arbor flange (E), and tighten screws (F).

6. Loosely assemble large washer and screw (C) Fig. 31, to the inside splitter bracket. This screw and washer was removed in **STEP 3**.

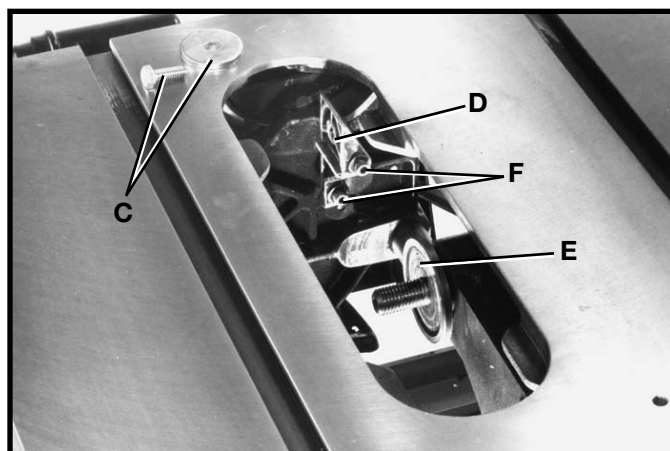

Fig. 31

7. Assemble the blade guard and splitter assembly (G) Fig. 32 between the large washer (C) and the splitter bracket and tighten screw (H) with wrench supplied.

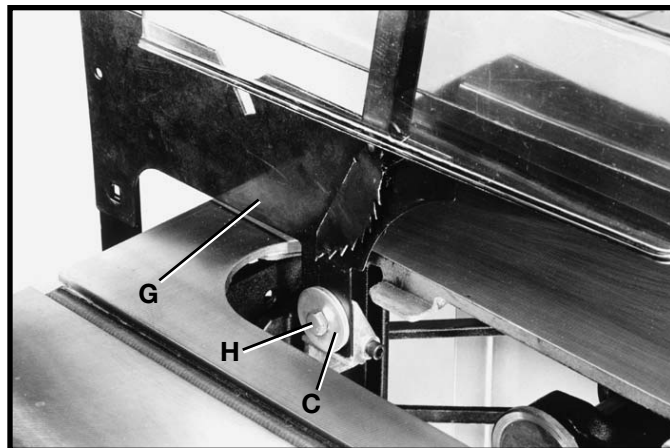

Fig. 32

8. Fasten the rear of the blade guard and splitter bracket assembly (G) Fig. 33, to the rear splitter mounting bracket using 5/16-18 x 5/8" carriage bolt (J), flat washer, and 5/16-18 hex nut. **IMPORTANT:** The splitter (G) Fig. 33, has a notch (L) cut in the top edge. This feature will enable the blade guard to stay in the raised position to make blade changing a little easier. Raise the front of blade guard (M) Fig. 34, until the rear edge of the blade guard slips into notch (L) of splitter (G); the blade guard will stay in this position.

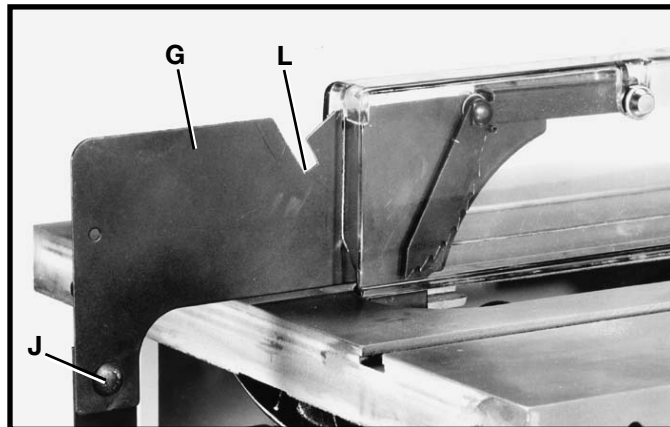

Fig. 33

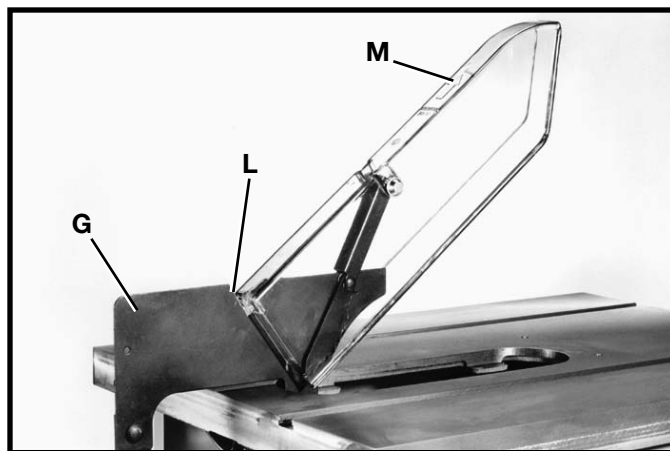

Fig. 34

9. With the blade guard (L) Fig. 35, in the raised position, assemble the saw blade (K) on the saw arbor with two arbor wrenches supplied.

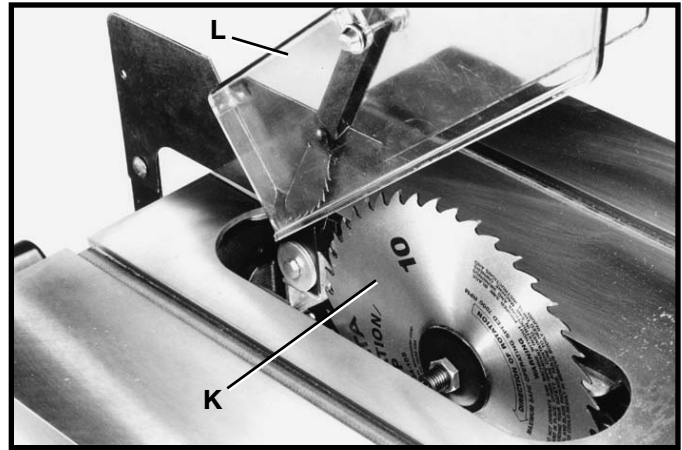

Fig. 35

10. Use a straight edge to check to see if the saw blade is aligned with the rear of the splitter (G) in Figs. 36 and 37. If alignment is necessary, loosen the screws (A) Fig. 37, align splitter (G) with the saw blade, and tighten two screws (A).

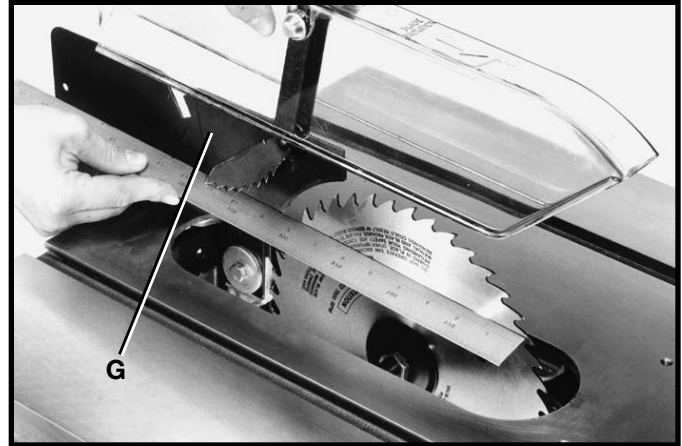

Fig. 36

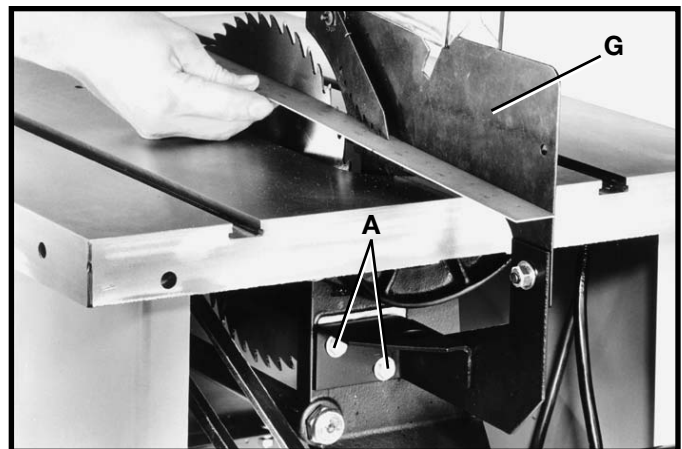

Fig. 37

11. Lower saw blade and install table insert (P) Fig. 38, in the saw table. **IMPORTANT:** When installing the table insert, make certain to hold on to the blade guard (L). The insert will automatically release the holding action on the splitter and lower the blade guard when it is installed in the table opening.



Fig. 38



## ASSEMBLING EXTENSION WING

1. Assemble extension wing (A) Fig. 39, to the saw table using three 7/16-20 x 1-1/4" screws (B) and lockwashers (C) Fig. 39.

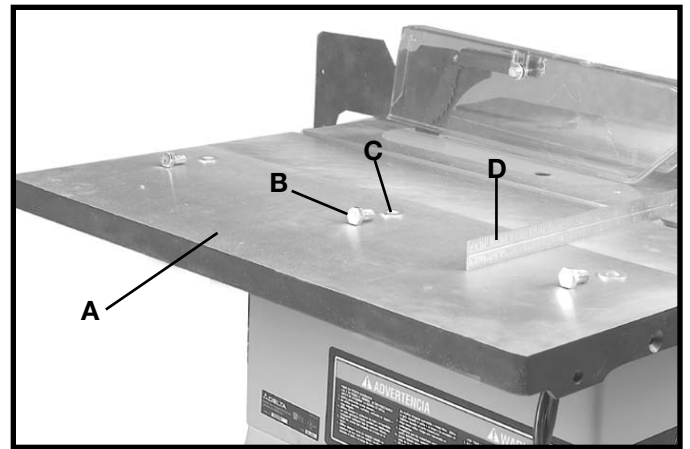

Fig. 39

2. With a straight edge (D) Fig. 39, make certain the extension wing (A) is level with the saw table before tightening three screws (B) Fig. 40.

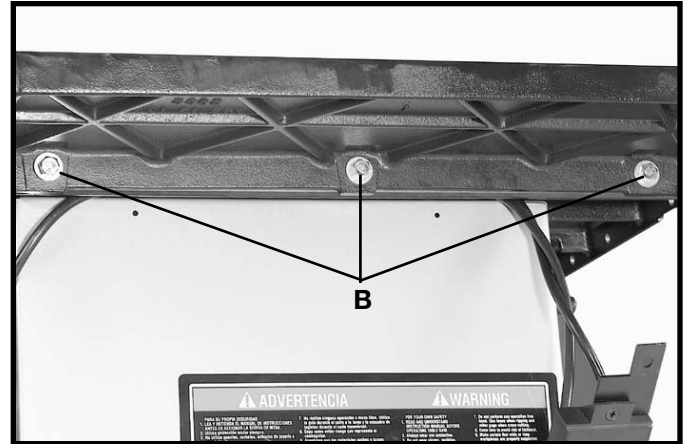

Fig. 40

## ASSEMBLING SWITCH TO EXTENSION WING

1. Assemble switch (A) Fig. 41, behind the lip of extension wing (B) insert 5/16-18 x 1" flat head screw (C), then assemble flat washer, and locknut.

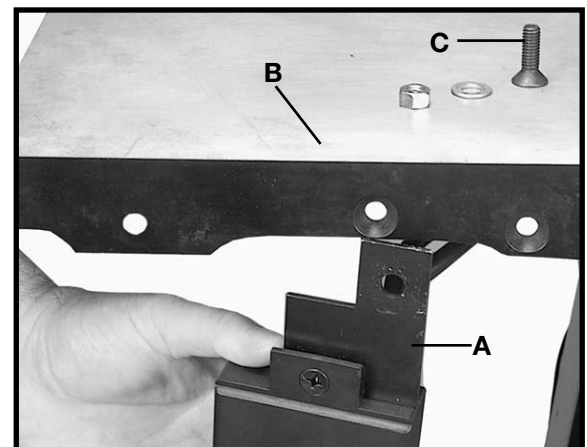

Fig. 41

2. Fig. 42 illustrates the switch assembled to the extension wing.



Fig. 42

# UNIFENCE ASSEMBLY INSTRUCTIONS

## ASSEMBLING TABLE BOARD TO SAW

1. Lay the table board upside down on the floor or bench, Fig. 44.
2. Assemble the two table legs (A) Fig. 45 to the bottom of the table using eight #8 x 3/4" self tapping wood screws. **NOTE:** Refer to Fig. 43 for the hole location for the 30" Unifence table legs.
3. Insert foot adapter (T) Fig. 46, into the bottom of each leg (A). Assemble the 3/8" jam nut (V) Fig. 46, approximately 3/4 of the way onto leveling screw (W) Fig. 46, into foot adapter. Fig. 47 illustrates the foot leveling assembly on the table leg. Assemble the remaining foot assembly to the other table leg in the same manner. **NOTE:** Height adjustments can be made later.

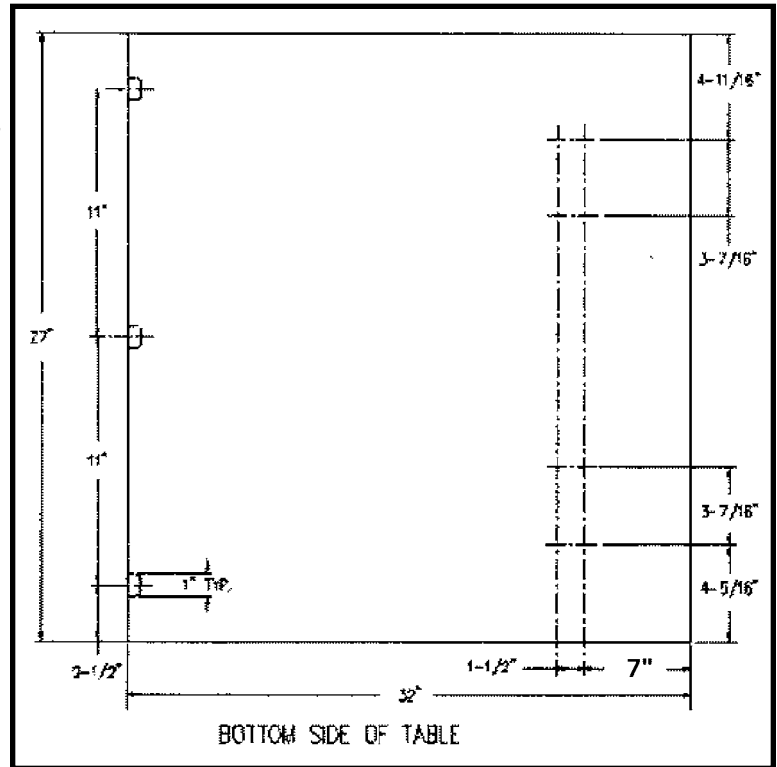

Fig. 43



Fig. 44

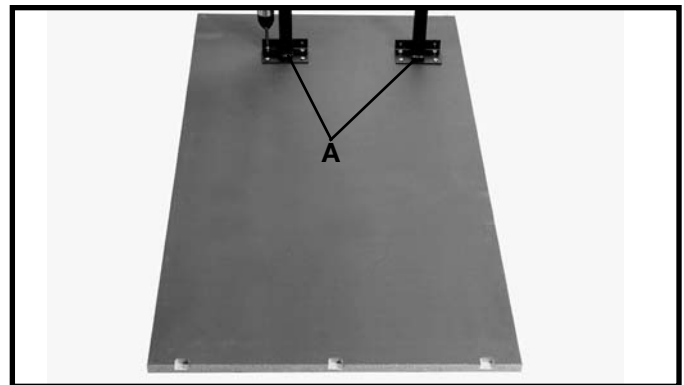

Fig. 45

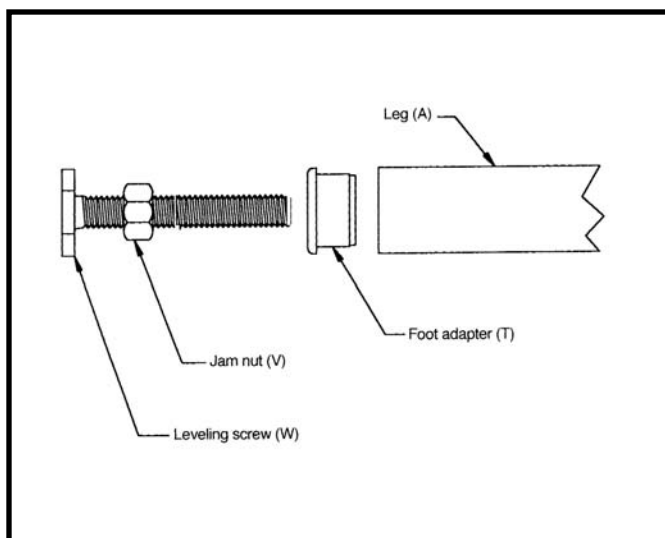

Fig. 46

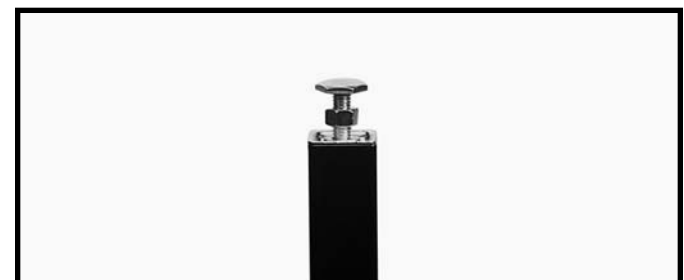

Fig. 47

4. Assemble shelf support bracket (M) Fig. 48 to the table legs (A) using two U-clamps (N), 1/4" flat washers, and 1/4-20 hex nuts (P). **NOTE:** Height adjustments to the bracket can be made later.

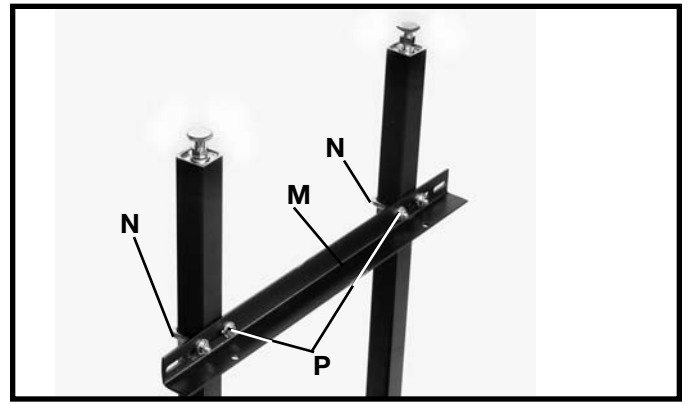

Fig. 48

5. Fasten the front table support (F) Fig. 49 to the bottom of the table using two #8 x 3/4" long self tapping wood screws (H) and (I) supplied. **NOTE:** The slots closer to the angles in the support (F) should be against the table and the vertical flange of the table support should be flush with the front edge of the table. **NOTE:** Screws (H) and (I) Fig. 49 should not be completely tightened to the table board at this time. **NOTE:** Make certain the end of the table support does not extend out past the table. **NOTE:** Screw (I) must be removed and reinstalled when table is mounted to the saw.

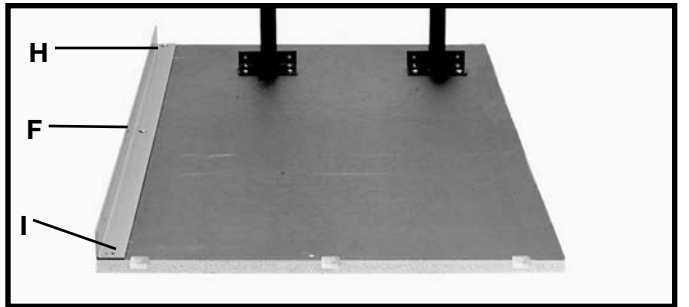

Fig. 49

**CAUTION: DO NOT OVER-TIGHTEN MOUNTING SCREWS.** Over-tightening screws in particle board may cause them to strip.

6. Fasten the rear table support (A) Fig. 50 to the saw table. Insert a 3/8-16 x 1" hex head screw (B), through hole in rear support and table, place a 3/8" washer onto the screw and thread a 3/8-16 hex nut onto screw and tighten. Repeat this process for the remaining hole. Hole (C) is not used on cast iron wing.

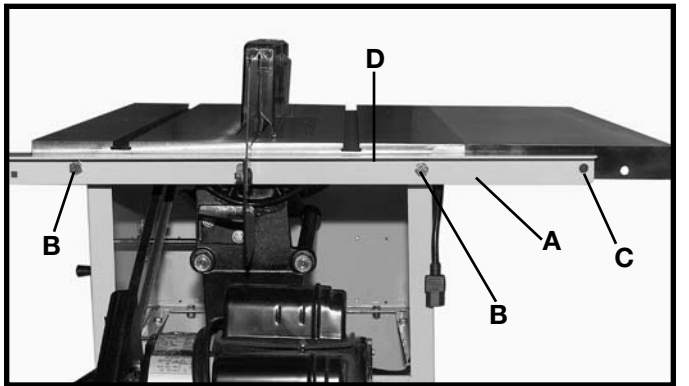

Fig. 50

7. Assemble the three brackets (J) to the table adapter plate (K) using the three 1/4-20 x 3/4" carriage bolts, nuts and washers (Fig. 51). **NOTE:** The long leg of the brackets (J) should be against the adapter plate (K). Do not completely tighten brackets (J) to adapter plate (K) at this time.

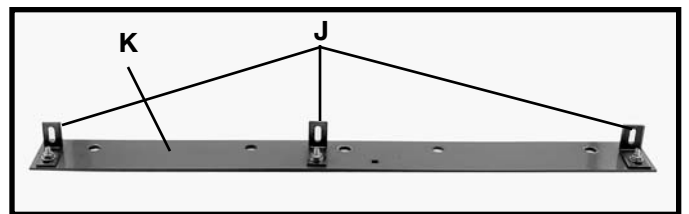

Fig. 51

8. Fasten the table adapter plate (B) Fig. 52 to the right side of the saw table. Place a 7/16" lockwasher onto a 7/16-20 x 1" hex head screw (D), insert screw through the table adapter plate and thread screw into right side of saw table. Repeat this process for the two remaining holes. **NOTE:** Before tightening screws (D), use a straight edge to make sure top of the adapter plate (B) is level with or slightly below surface of the saw table. Also make sure that the front edge of the adapter (B) does not stick out past the front edge of the saw table.

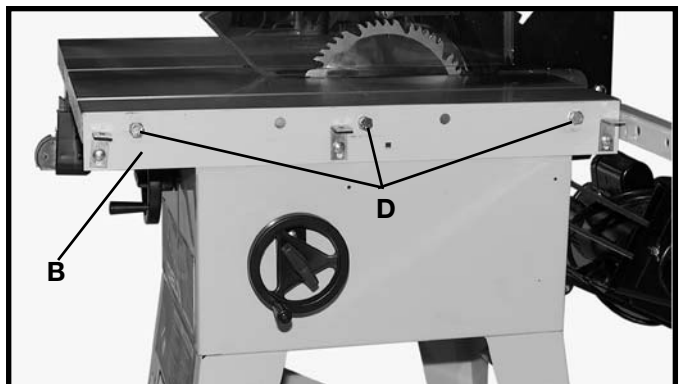

Fig. 52

# ASSEMBLING UNIFENCE TABLE TO SAW

1. Remove screw (I) Fig. 49 (D Fig. 54) before placing table on brackets. Position table board (A) Fig. 53 on three angle brackets (B).

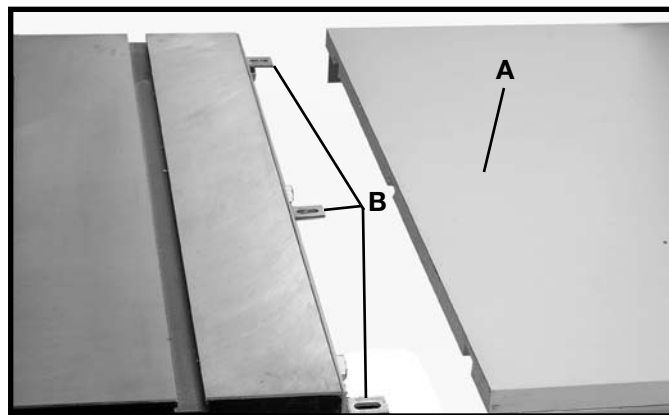

Fig. 53

2. While holding table board firmly against the saw adapter plate, fasten the table to the three brackets using three #8x7/8" wood screws (D), (E), and (F), Fig. 54. **NOTE:** The two screws (E) and (F), Fig. 54 can be tightened. Screw (D) Fig. 54 should be left slightly loose at this time.



Fig. 54

**CAUTION: DO NOT OVER-TIGHTEN TABLE MOUNTING SCREWS.** Over-tightening screws in particle board may cause them to strip.

3. Assemble the two brackets (J) to the rear guide rail (K) using the two 1/4-20 x 3/4" carriage bolts placing bolts through holes, then washers and nuts (L), Fig. 55. **NOTE:** The long leg of the brackets (J) should be against the bottom of the table (A).

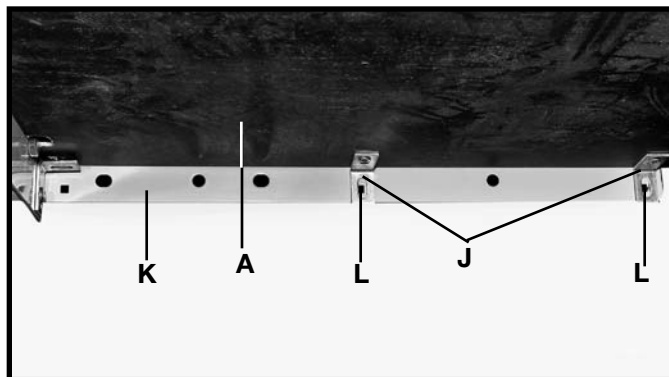

Fig. 55

4. Fasten the table (A) to the two brackets (J) on the rear guide rail (K) Fig. 56, using two #8x7/8" wood screws.

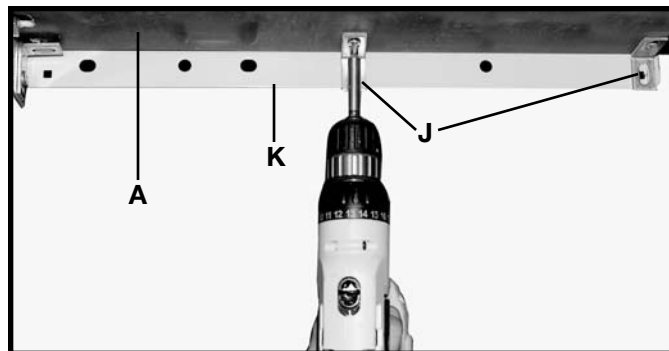

Fig. 56

5. Using a straight edge (S) Fig. 57, make certain the surface of the Unifence table is level with the saw table by adjusting the height of the two leveling screws (E) Fig. 58 at the base of the table legs, and adjusting the height of angle brackets (B) Fig. 53. Position hex nuts (H) Fig. 58, against the bottom of the table legs to hold the leveling screws in position and tighten. **IMPORTANT:** Use a level, side to side and front to back, to make sure the Unifence table is level with the saw table.

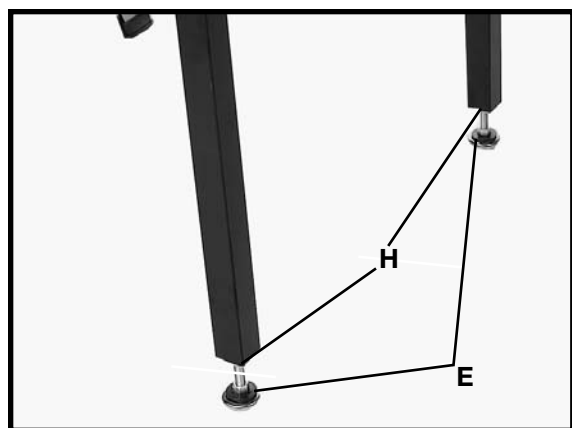

Fig. 58

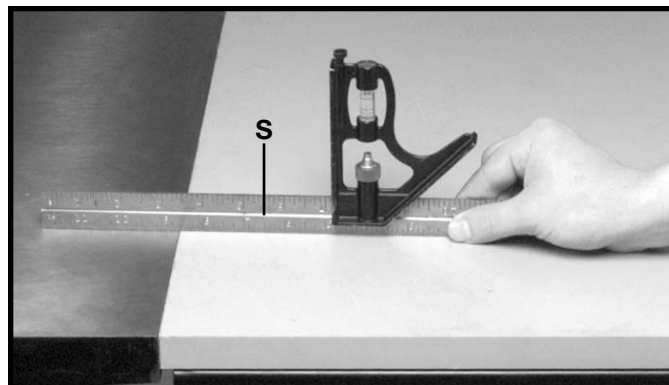

Fig. 57



# ASSEMBLING UNIFENCE GUIDE RAIL

1. Locate the T-Slot Guide Rail and mounting hardware Fig. 59 from the packing material of the Unifence. Remove the end caps (A) Fig. 59, prior to assembly, by inserting a flat headed screwdriver (B) into the channel and tap gently. **NOTE:** Take care not to damage either the cap or the rail.

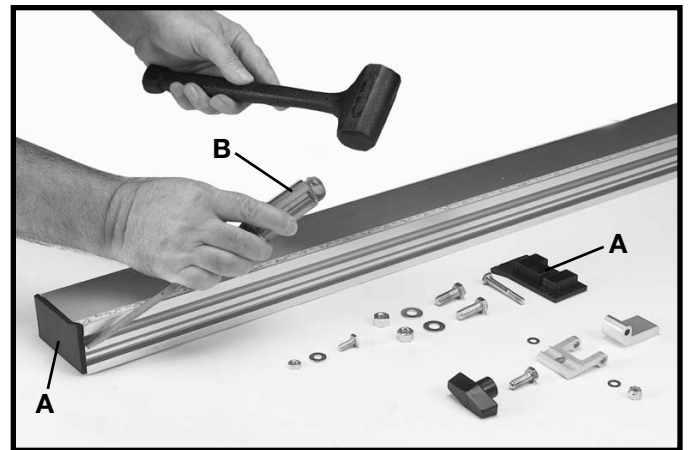

Fig. 59

2. Insert two 3/8-24 x 1" hex head bolts, flat washers and hex nuts (C) Fig. 60 into the two holes (F) Fig. 60 in the front of saw table (G). Screw bolts into nuts slightly leaving bolt head extended approximately 1/2". **Note:** Make sure to use only the two holes shown at (F) and that washers are on the nut side of the bolt.

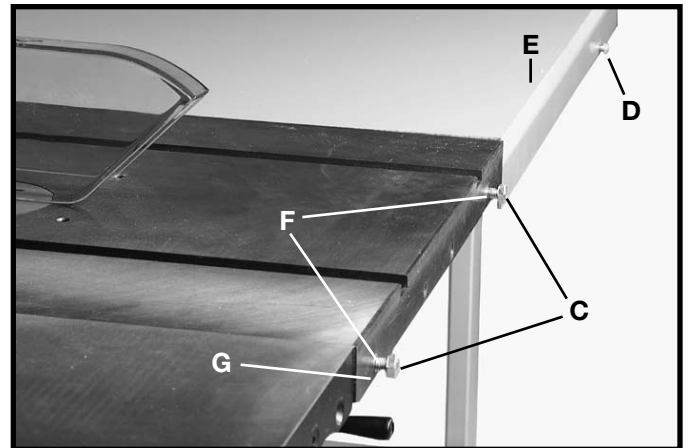

Fig. 60

3. Insert one 1/4-20 x 3/4" hex head bolt, flat washer and hex nut (D) Fig. 60, into the front support of the extension table (E) Fig. 60. Screw bolt into nut slightly leaving bolt head extended approximately 1/4". Make sure washer is on the nut side of the bolt.

4. From either end, slide the T-Slot guide rail (A) Fig. 61 on the hex head of the bolts partially inserted in step 2 and 3 above. **Note:** The bolt heads on the saw table, slide into the upper t-slot (B) Fig. 61 and the bolt head on the extension table slide into the lower t-slot (C) Fig. 61.

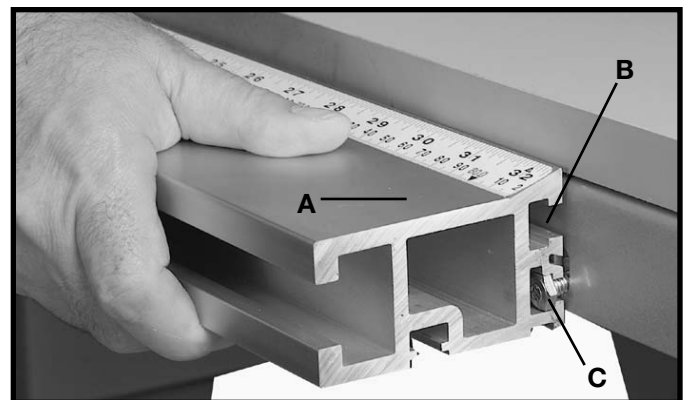

Fig. 61

5. Slide the guide rail along until the 0" on the unifence scale is aligned with the right edge of the saw table. Snug the hex nuts on the saw and extension table, but do not tighten at this time.

6. Adjust the guide rail (C) Fig. 62 parallel with the saw table surface by placing a square (H) on the saw table at both the left front end of the saw table (A) and the right front end of the extension table (B), with the rule of the square against the flat surface on top of the guide rail. The guide rail (C) Fig. 62, can be adjusted up or down slightly at either end. After being certain the guide rail is parallel with the table surface, firmly tighten the two hex nuts that fasten the guide rail to the table. **Note:** Make sure 0" (D) on the unifence scale is aligned with the right edge of the saw table (E).

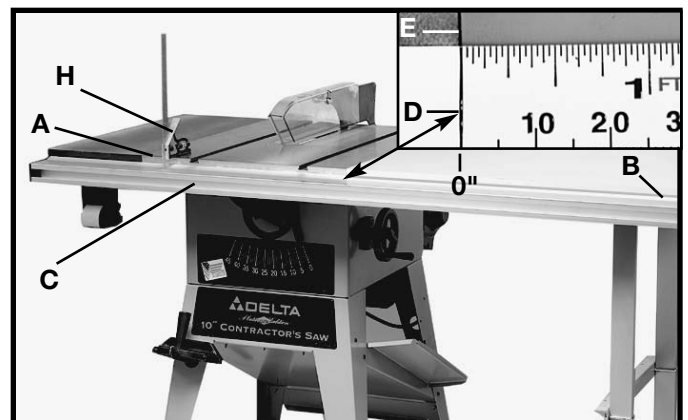

Fig. 62



7. Move the square (H) Fig. 62, to the end of the Unifence table and check to make certain the same distance is kept from the top surface of the extension table (K) to the top surface of the guide rail (C). Move the front table support (L) Fig. 63, against the guide rail (C), and fasten with 1/4-20 nut and flat washer (M). Tighten two screws, one of which is shown at (N) Fig. 63, that fasten the Unifence table to the guide rail.

## ASSEMBLING RAIL STOP

1. The Unifence Flip Stop, Fig. 64, can be easily assembled by inserting flip stop (A) into fence slide stop (B) which is held in place by inserting 1/4-20 x 2" hex head bolt (C), fiber washers (D) and tightening hex nut (E). Make sure fiber washers are placed on both sides of flip stop (A) when assembled. Do not over tighten hex nut (E). The flip stop must fit snugly but move freely.

2. The Rail Stop Assembly, Fig. 65, can then be attached to the guide rail by inserting head of 5/16-18 (F) hex head bolt into T-Slot (G) positioning the stop assembly to the rail and tightening knob (H) finger tight.

3. Use a rubber mallet (P) Fig. 66, or a hammer and a block of wood, to gently tap end cap (R) into both ends of the guide rail (C). **NOTE:** To avoid damage to the guide rail, **DO NOT** use a metal hammer directly against the guide rail.

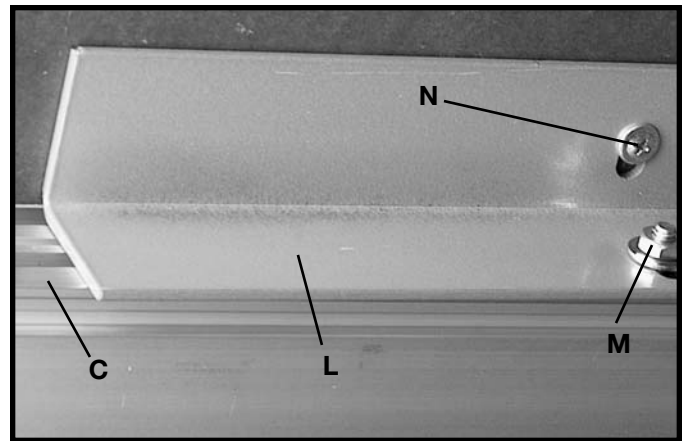

Fig. 63

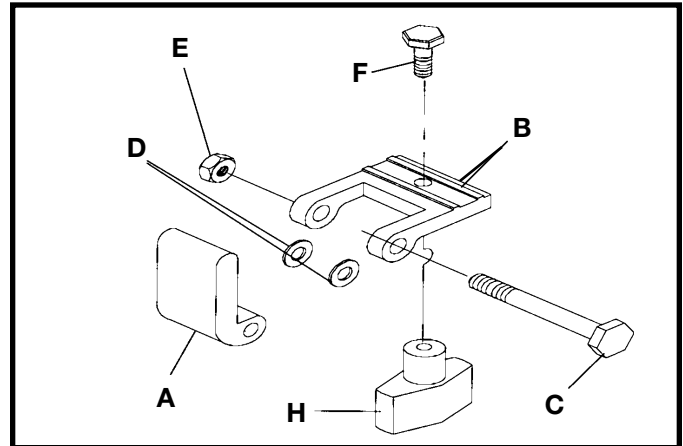

Fig. 64

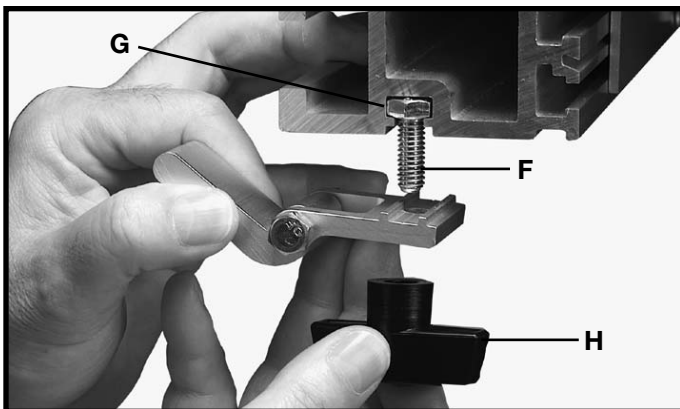

Fig. 65

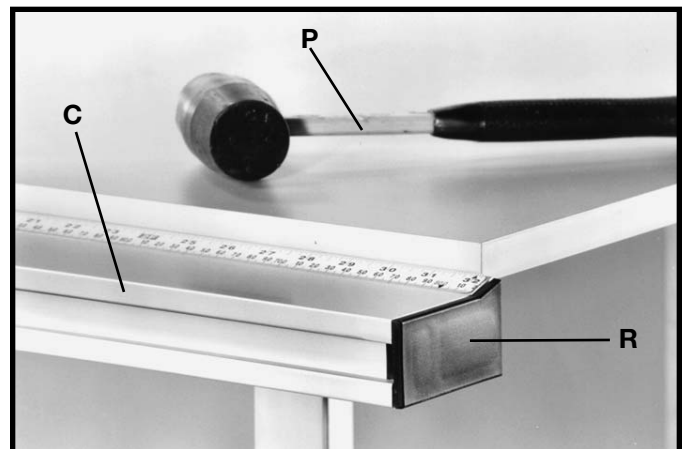

Fig. 66

## SETTING T-SLOT RAIL STOP

1. The Rail Stop Assembly Fig. 67 (A) can be set to any number of positions along the guide rail providing a quick stop setting for the Unifence body by loosening knob (B) and sliding the stop along the rail to the desired position (←→) and re-tighten.

**NOTE:** Any number of stops can be purchased and installed to provide time saving quick stop adjustment for the Unifence body.

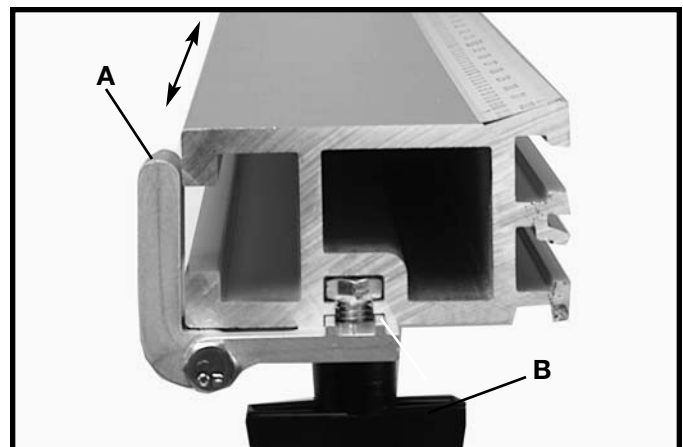

Fig. 67

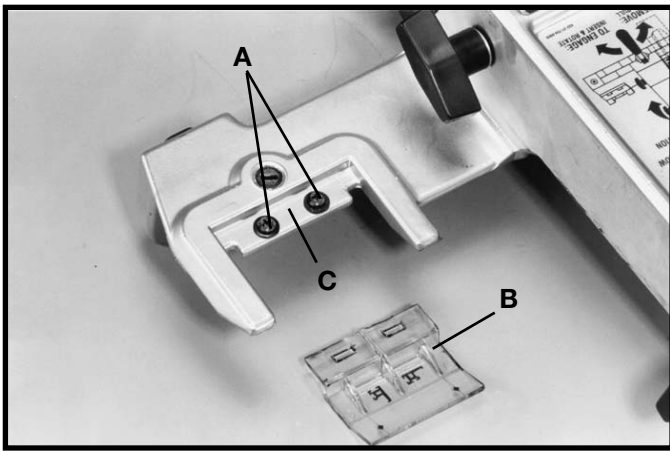

Fig. 68

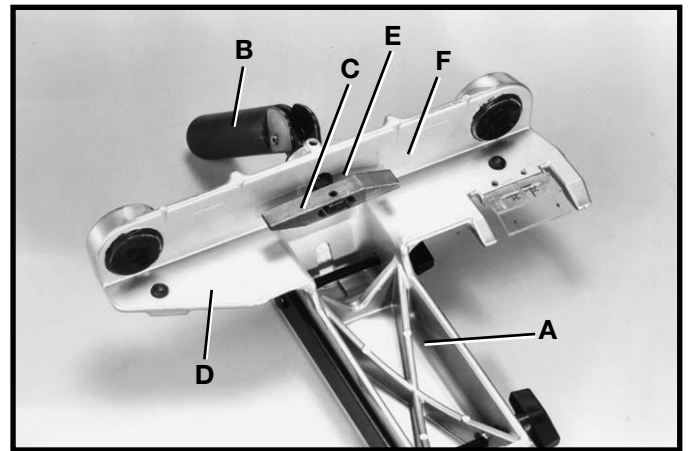

Fig. 70

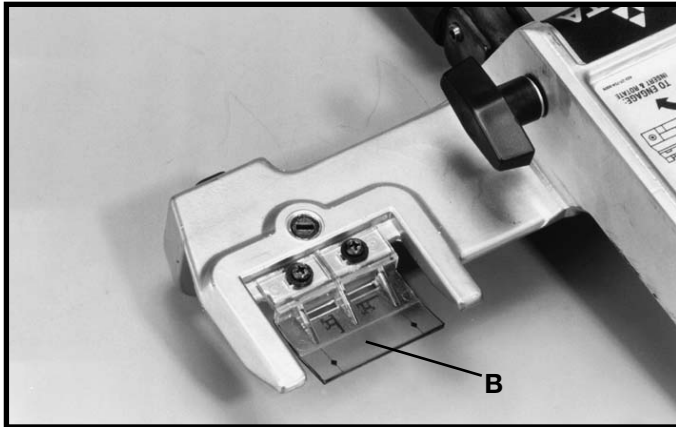

Fig. 69

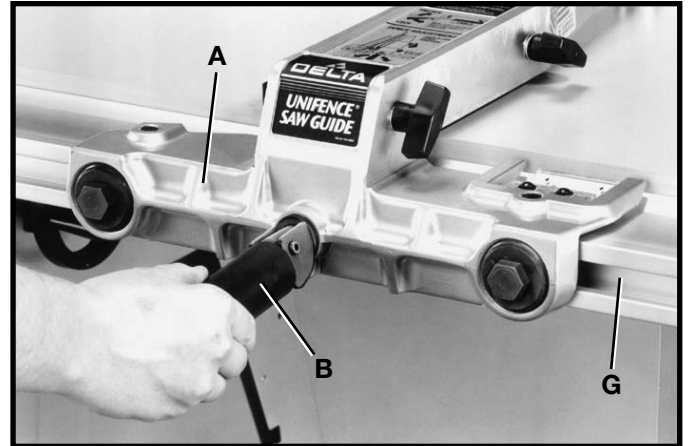

Fig. 71

## ASSEMBLING CURSOR TO UNIFENCE BODY

1. Remove two screws and flat washers (A) Fig. 68, and assemble the cursor (B) to the Unifence body (C). Replace the two screws and flat washers (A).
2. Fig. 69 illustrates the cursor (B) assembled to the Unifence body. Final adjustment to the cursor (B) will be made later.

## ASSEMBLING UNIFENCE BODY TO GUIDE RAIL

1. Turn fence body (A) Fig. 70, upside down and lay it on a table or bench. Push handle (B) in against fence body. Make certain the surface (C) of clamp bracket is parallel to the face (D) of the fence body, and that the inside edge (E) of the clamp bracket is parallel to surface (F) of the fence body. Turn handle (B) Fig. 70, if necessary.
2. Place fence body (A) Fig. 71, onto the guide rail, making sure that the clamp bracket is inserted into channel (G) on rail. Notice that the clamp handle (B) is turned to the left indent position.
3. Turn handle (B) Fig. 72, to the right indent position. This action will prevent fence clamp from sliding out of the channel (G).
4. Lock fence body (A) to the guide rail by pushing down on handle (B) Fig. 73.

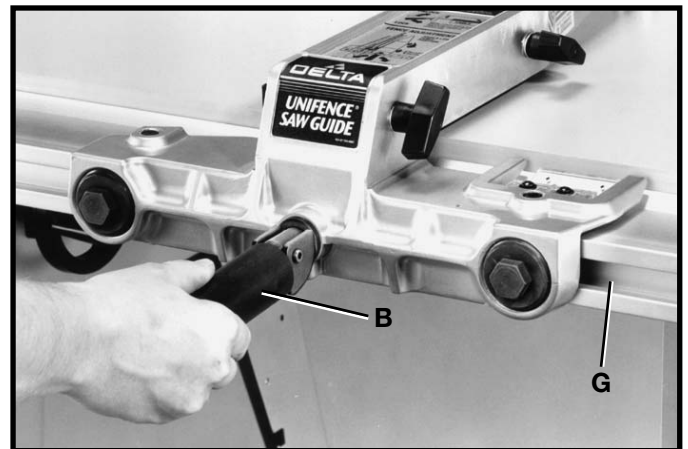

Fig. 72

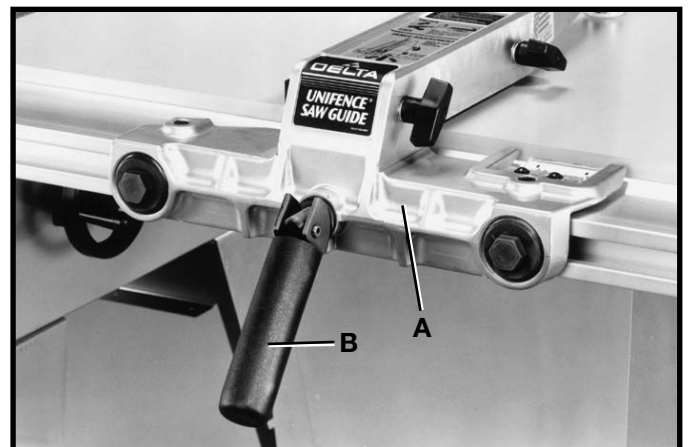

Fig. 73

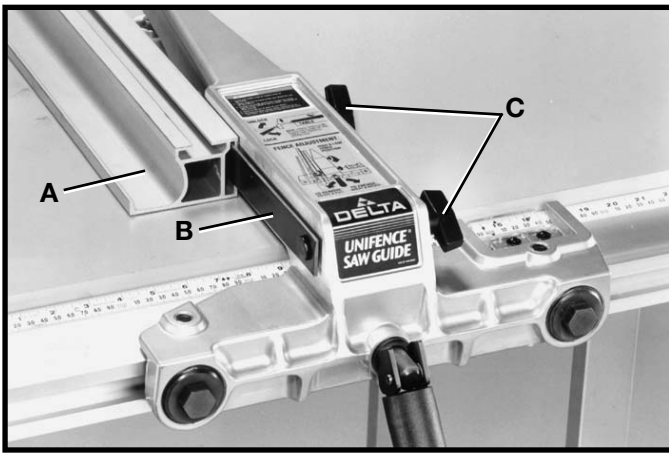

Fig. 74

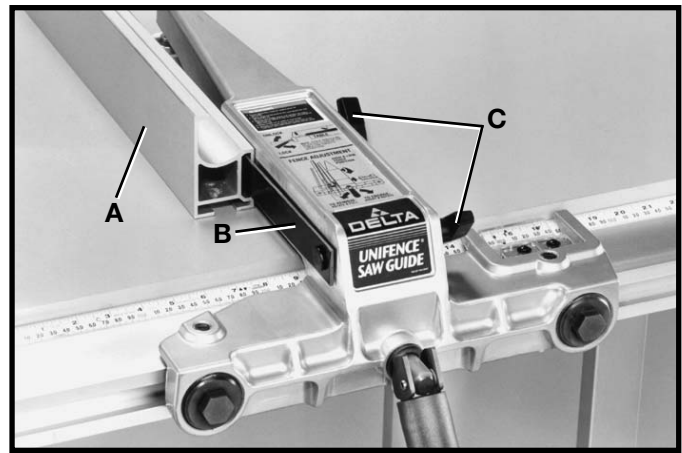

Fig. 75

## ASSEMBLING UNIFENCE TO UNIFENCE BODY

1. The fence (A) can be assembled to clamp plate (B) in either the horizontal position as shown in Fig. 74, or the vertical position as shown in Fig. 75. Make certain that the two lock knobs (C) are loose and slide fence (A) onto clamp plate (B) as shown. Then tighten the two lock knobs (C).
2. For most cutting operations, the bottom of the fence should be positioned slightly above the table surface. Loosen two lock knobs (C) Fig. 76, and place a thin object such as a scale (D) between the table and fence. Tighten two lock knobs (C).

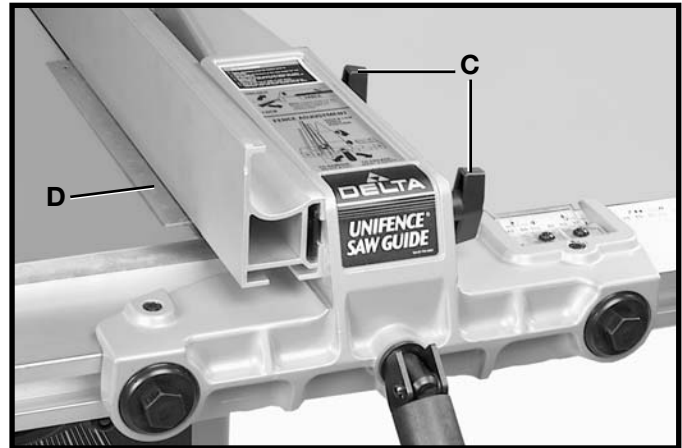

Fig. 76

## BIESEMEYER T-SQUARE FENCE SYSTEM ASSEMBLY INSTRUCTIONS

1. **⚠ WARNING: DISCONNECT MACHINE FROM POWER SOURCE.**
2. Assemble the front rail (A) Fig. 77 to front of saw table using the two 3/8-16 x 1-1/4" long flat head Phillips screws (B), 7/8" flat washers, lock washers and 3/8-16 hex nuts supplied. Screws (B) are inserted through the two holes in the front rail, and through the two through-holes in the front of the saw table, and fastened to the table with the flat washers, lockwashers, and hex nuts. **IMPORTANT: Do not completely tighten front rail mounting hardware at this time.**



Fig. 77

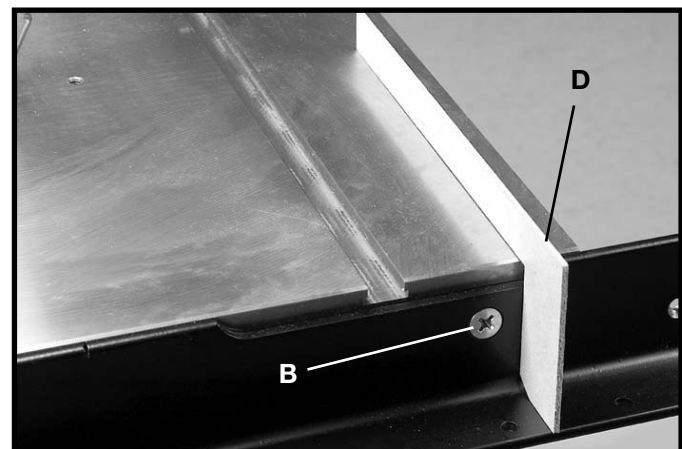

Fig. 78



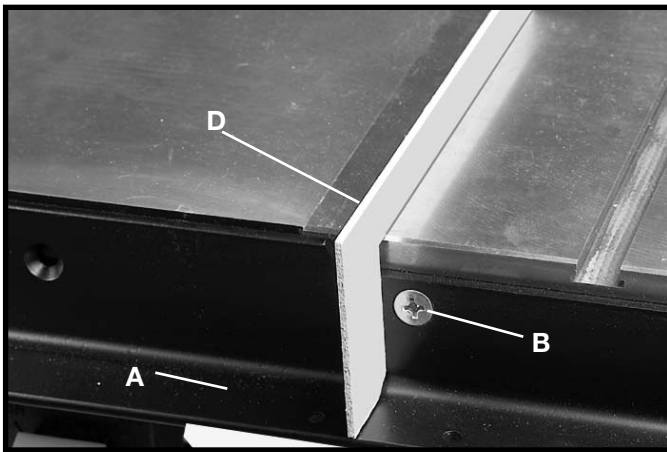

Fig. 79

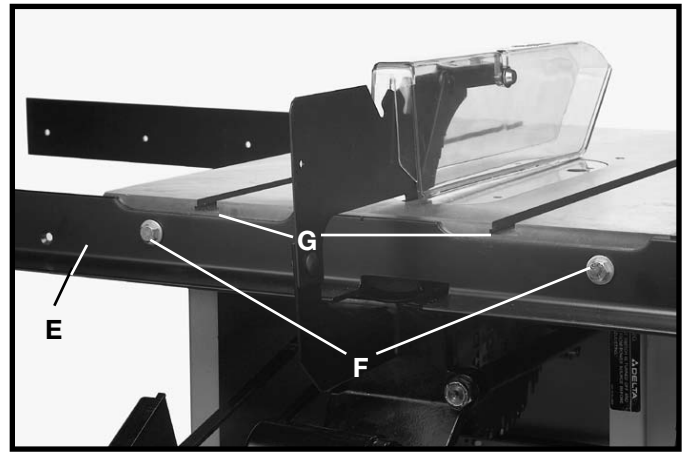

Fig. 80

3. Using the template (D) Figures 78 and 79, check and adjust front rail at both ends of the saw table to make sure rail (A) is level with table surface. Tighten rail mounting hardware (B). **IMPORTANT: Template (D) must be on saw table when checking, not on extension wing.**

4. Assemble rear rail (E) Fig. 80 to rear of saw table using the two 3/8-24 x 1-1/4" long hex head screws (F), 7/8" flat washers, 3/8-24nuts and 3/8" lockwashers (not shown). Place flat washer on bolt, then assemble bolt into rear rail, then assemble lockwasher and nut.

5. Make certain top edge of rail (E) Fig. 80 is below table surface, and that top edge of cut-outs (G) are below miter gage slots before tightening screws (F).

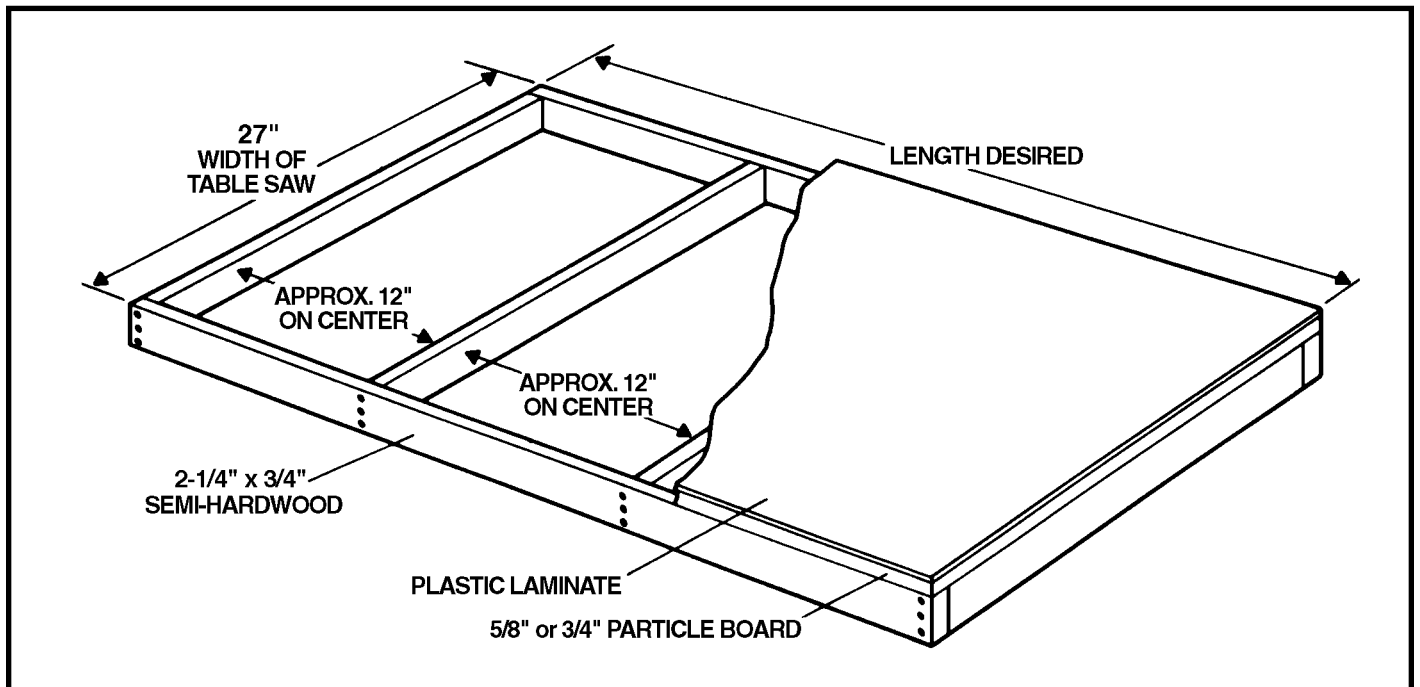

Fig. 81

6. If the accessory right extension table for use with the T-Square® fence was not purchased, construct an extension table by following the dimensions shown in Fig. 81.



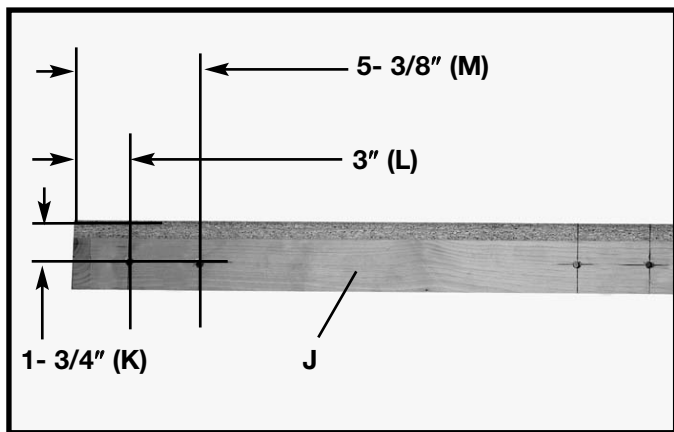

Fig. 82

7. Mark the position of the four leg mounting holes from each end of the table (Fig. 82). Use a 1/4" drill bit to drill four through holes through the end piece (J) of the table at the dimensions shown at (K) (L) and (M).

8. Position the two legs (H) Fig. 83. Assemble the four 1/4-20 x 1-1/2" leg mounting screws, washers, and hex nuts (I) into holes drilled in step 7 and tighten. Mark the eight holes (P) to attach the legs to the table top. Remove the screws and two legs (H). Using a 1/16" drill bit, drill the eight holes 1/2" deep.

**CAUTION: DO NOT OVER-TIGHTEN MOUNTING SCREWS.** Over-tightening screws in particle board may cause them to strip.

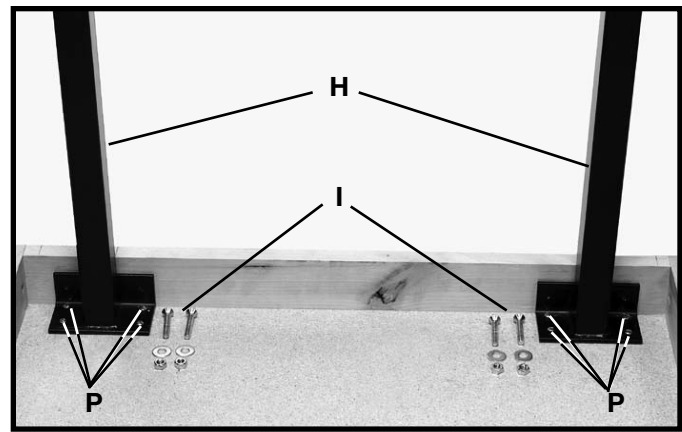

Fig. 83

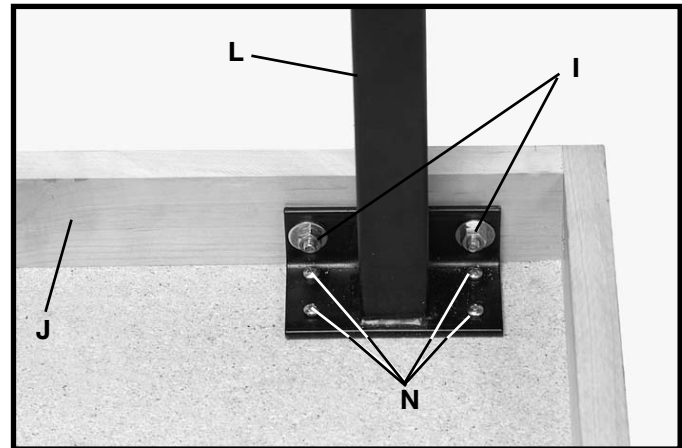

Fig. 84

**IMPORTANT NOTE: If your saw and fence system will be used with a mobile base underneath the saw base and table legs, the position of the legs may have to be changed to fit onto the mobile base.**

9. Fasten the leg bracket (L) Fig. 84, to the underside of table top using the eight 3/4" long wood screws [four are shown at (N) Fig. 84]. Assemble the four 1-1/2" long flat head Phillips screws, flat washers and hex nuts (I) to the end piece (J) of the table and retighten. Fasten the remaining leg to the extension table in the same manner.

10. Place table assembly (N) Fig. 85, in position between the two rails. Make sure end of table (O) is flush against saw table (P). Use a bar clamp (Q) to snug up end of rails to hold table in position. Use a straight edge to make sure table (O) is in the same plane and level with saw table (P). Lightly tap table up or down, and adjust leveling screws (R) Fig. 86 in bottom of legs. When the table (O) Fig. 85 is level and in the same plane with saw table (P), tighten bar clamp (Q) to hold in position. Then drill 1/4" through-holes in the front and rear of the extension table, using the holes (S) provided in rails as template.

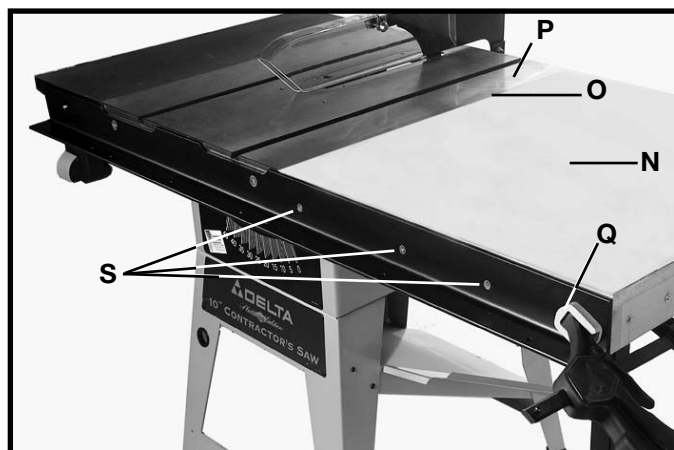

Fig. 85

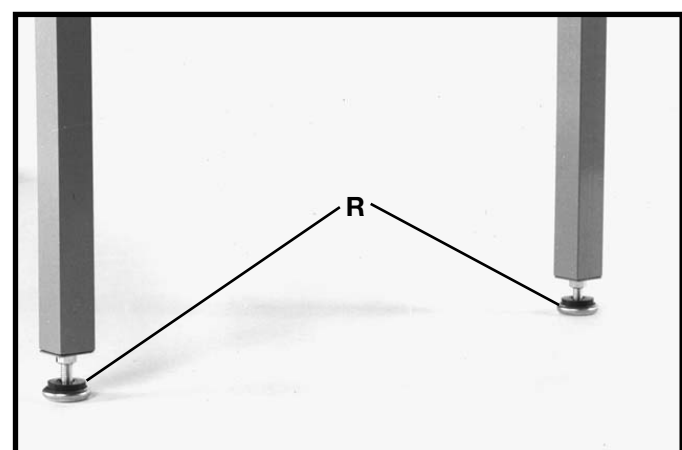

Fig. 86

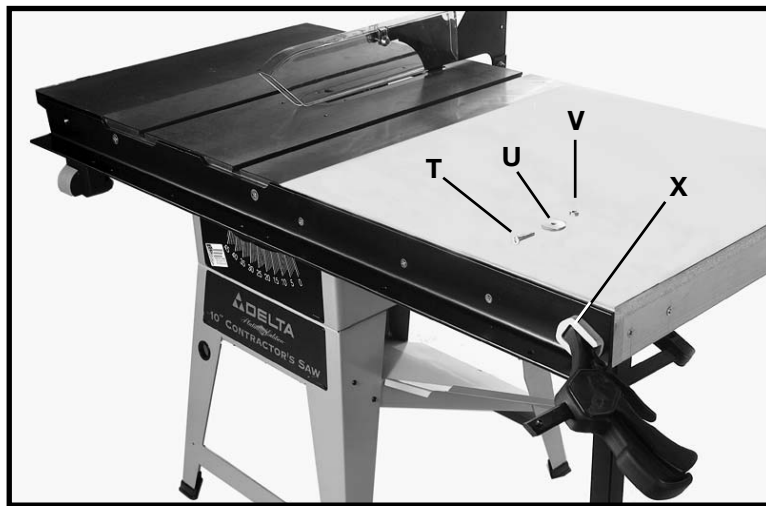

Fig. 87

11. After the holes have been drilled in the edge of the front and rear extension table board, fasten both front and rear rail to table using the 1-1/2" flat head Phillips screws (T) Fig. 87, 1-1/4" O.D. flat washers (U) and hex nuts (V). **NOTE:** The 1-1/4" flat washer cannot be used on the end holes (X) shown covered by clamp.

12. Lay the guide tube (B) Fig. 88, on the saw table, and line up the threaded holes (C) on bottom of guide tube (B) with the through-holes (D) on the front rail (A) in seven places.

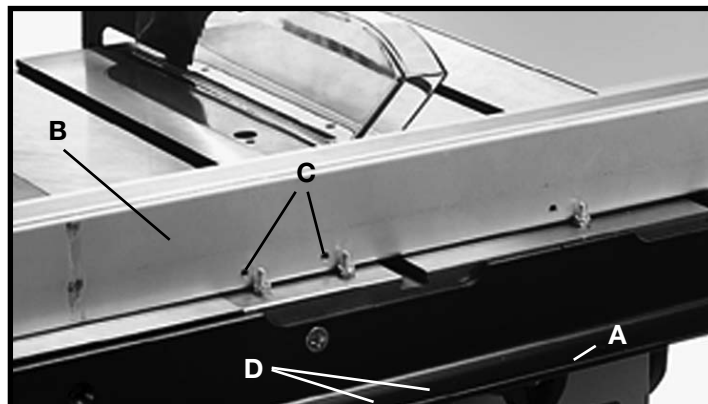

Fig. 88

13. Position the guide tube (B) Fig. 89 on the front rail and fasten the guide tube to the rail using the 1/4-20 x 1/2" long hex head screws (G) and lockwashers in seven places. Place lockwasher onto screw and assemble into rail.

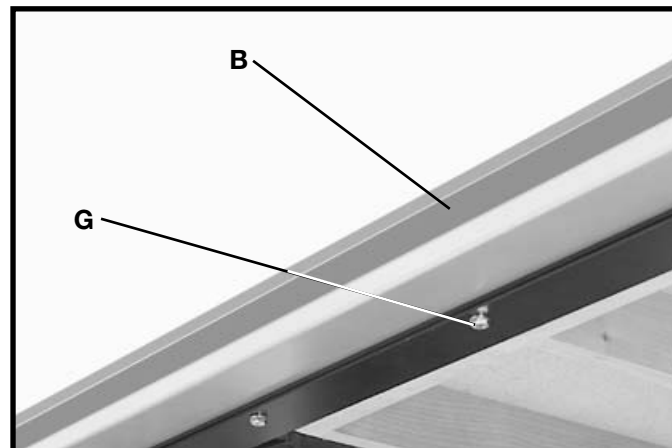

Fig. 89

# FASTENING STAND TO SUPPORTING SURFACE

IF, DURING OPERATION, ANY TENDENCY EXISTS FOR THE SAW TO TIP OVER, SLIDE OR WALK ON THE SUPPORTING SURFACE, THE SAW STAND SHOULD BE SECURED TO THE FLOOR SURFACE. THE RUBBER FEET OF THE STAND FEATURE HOLES WHICH ALLOW EASY MOUNTING WITHOUT REMOVING THE SAW FROM THE STAND.

## OPERATING CONTROLS AND ADJUSTMENTS

### STARTING AND STOPPING SAW

1. The on/off switch is located underneath the switch shield (A) Fig. 94. To turn the saw "ON," move switch trigger (B) to the up position.
2. To turn the saw "OFF," simply push down on switch shield (A) Fig. 95.

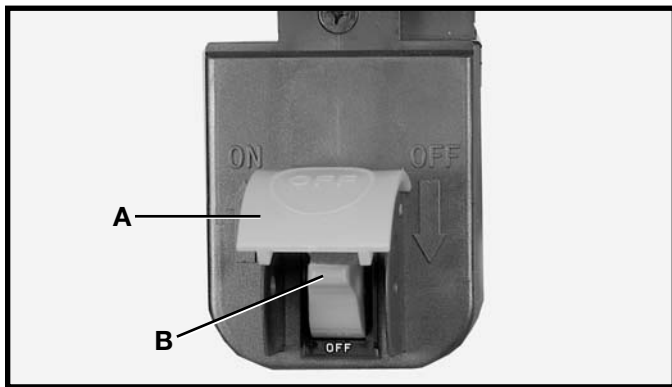

Fig. 94

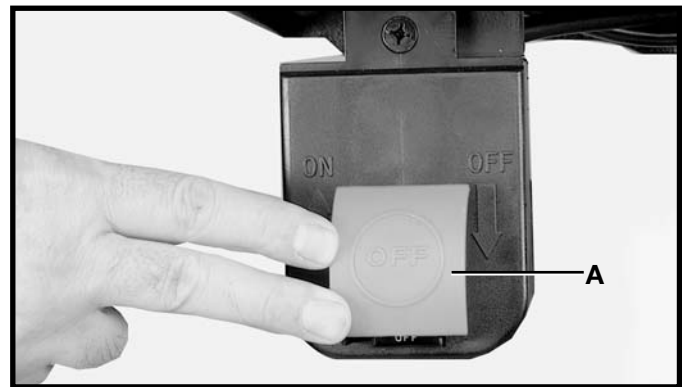

Fig. 95

### LOCKING SWITCH IN THE "OFF" POSITION

**IMPORTANT:** When the machine is not in use, the switch should be locked in the "OFF" position to prevent unauthorized use, using a padlock (C) Fig. 96 with a 3/16" diameter shackle.

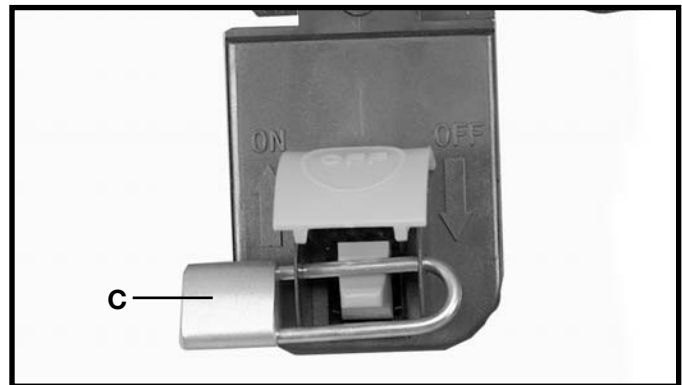

Fig. 96

### OVERLOAD PROTECTION

The motor supplied for use with your saw is equipped with a reset overload relay button (A) Fig. 97. If the motor shuts off or fails to start due to overloading (cutting stock too fast, using a dull blade, using the saw beyond its capacity, etc.), or low voltage, turn the switch to the "OFF" position, let the motor cool three to five minutes, and push the reset button (A). The motor can then be turned on again in the usual manner.

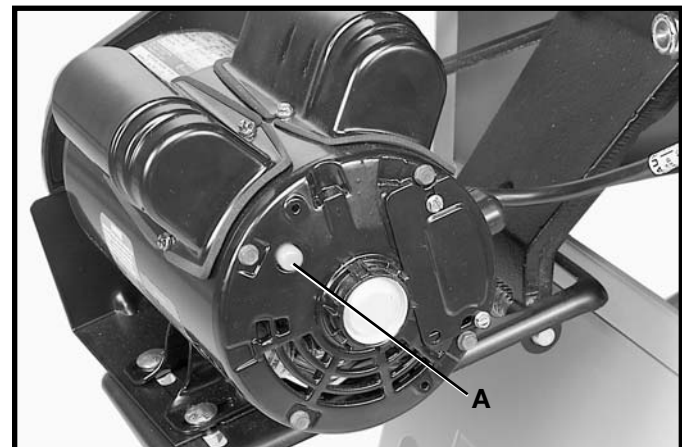

Fig. 97

# RAISING AND LOWERING THE BLADE

To raise the saw blade, loosen lock knob (A) Fig. 98, and turn the blade raising handwheel (B) clockwise. When the blade is at the desired height, tighten lock knob (A).

To lower the blade, loosen lock knob (A) Fig. 98, and turn the handwheel (B) counterclockwise. **NOTE:** One full turn of the handwheel will change blade height approximately 1/4".

# TILTING THE BLADE

To tilt the saw blade for bevel cutting, loosen lock knob (D) Fig. 98, and turn the tilting handwheel (C). When the desired blade angle as shown on scale and pointer (E), tighten lock knob (D).

# ADJUSTING 90 DEGREE AND 45 DEGREE POSITIVE STOPS

The machine is equipped with positive stops that will quickly and accurately position the saw blade at 90 degrees and 45 degrees to the table. To check and adjust the positive stops, proceed as follows:

1.  **WARNING:** When adjusting the positive stops, make certain the machine is disconnected from the power source.
2. Raise the saw blade to its highest position.
3. Set the blade at 90 degrees to the table by turning the blade tilting handwheel counterclockwise as far as it will go.
4. Use a combination square (A) Fig. 99 to see if the blade is at 90 degrees to the table surface.
5. If the blade is not at 90 degrees to the table, loosen set screw (B) Fig. 99 with 5/32" allen wrench (C), and turn the blade tilting handwheel until the blade is 90 degrees to the table. Turn set screw (B) clockwise until it bottoms.
6. Adjust the pointer (D) Fig. 100 to point to the zero degree mark on the scale by loosening screw (E), adjusting pointer (D), and tightening screw (E).
7. Turn the blade tilting handwheel clockwise as far as it will go and use a combination square to see if the blade is at 45 degrees to the table.
8. If the blade is not at 45 degrees to the table, loosen set screw (F) Fig. 99, and turn blade tilting handwheel until the blade is 45 degrees to the table. Turn set screw (F) clockwise until it bottoms.

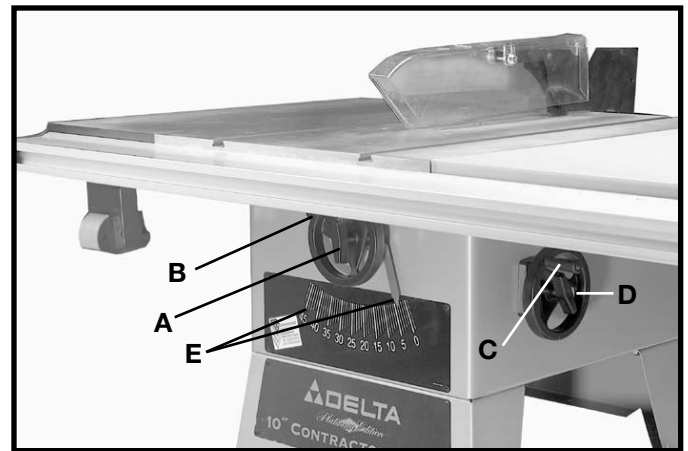

Fig. 98

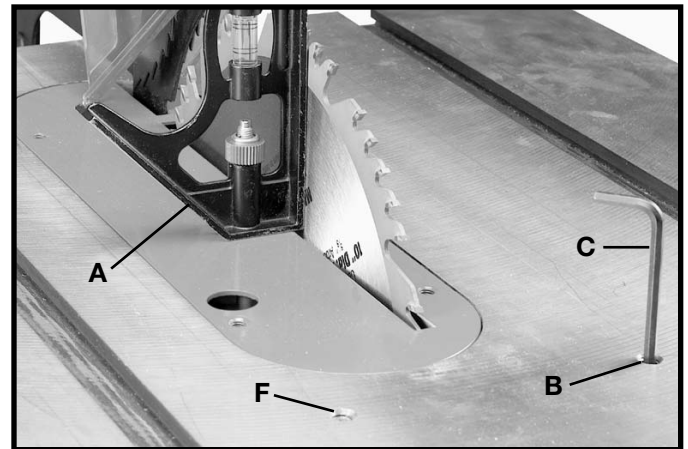

Fig. 99

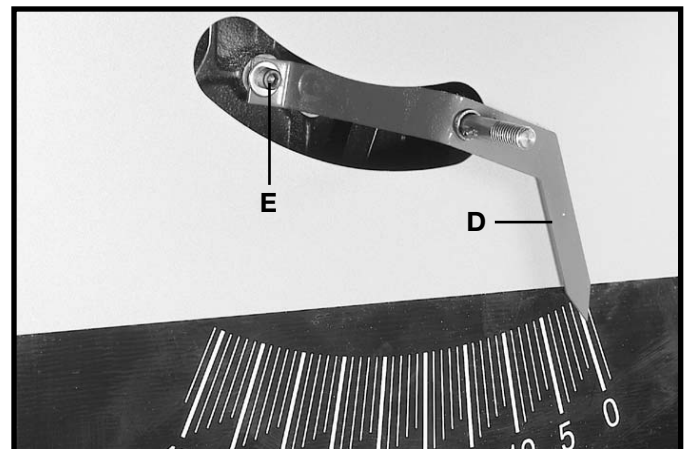

Fig. 100



# BACKLASH ADJUSTMENTS FOR BLADE RAISING AND BLADE TILTING MECHANISMS

After a period of extended use, if any play is detected in the blade raising or blade tilting mechanisms, make the following adjustments:

**⚠ WARNING: Disconnect machine from power source.**

2. **NOTE:** The machine has been turned upside down and the blade removed for clarity and safety.

3. **Adjusting blade raising mechanism** - Loosen locknut (A) Fig. 101, and turn eccentric sleeve (B) until all play is removed in mechanism and tighten locknut (A).

4. **Adjusting blade tilting mechanism** - Loosen locknut (C) Fig. 101, and turn eccentric (D) until all play is removed in mechanism and tighten locknut (C).

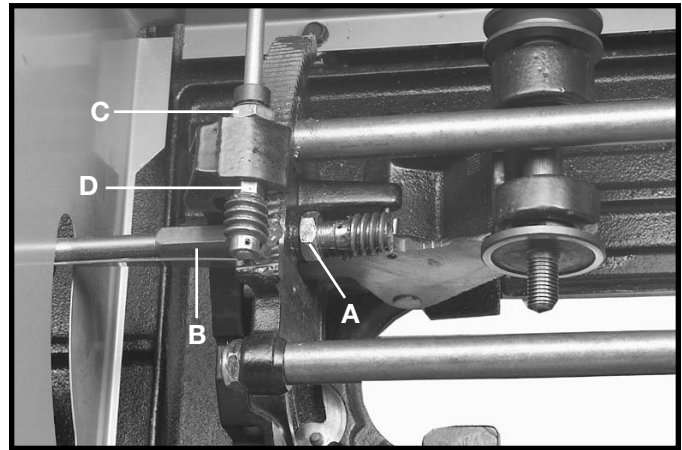

Fig. 101

## CHECKING BLADE ALIGNMENT

1. **⚠ WARNING: Disconnect machine from power source.**

2. Raise blade guard and adjust blade to its highest position. Mark one side of one saw blade tooth (F) with a dark colored marker Fig. 101A. Rotate the blade toward the front of the saw by hand until the marked tooth is at the top of the table.

3. Insert the miter gage into miter gage slot and position near the front edge of the blade. With a combination square (G), place the straight edge along the face of the miter gage. Position the end of the straight edge (H) to lightly contact the side of the marked tooth.

4. Firmly hold the straight edge in place while rotating blade to the rear side of the table. Firmly hold the straight edge in place to re-position the miter gage to the rear side of the saw table (Fig. 101B). Rotate the mark (made in step 2) on the blade (F) to end of straight edge to check blade alignment gap. The marked tooth (F) should be the same distance from the end of the straight edge in front and rear positions.

5. Repeat this procedure moving from front to rear until you have visual confirmation of the blade alignment. **NOTE:** All saw blades have some run-out. Therefore check the alignment each time a blade is changed.

6. If the blade alignment is off by .010" or the approximate thickness of a standard business card, follow **(ADJUSTING BLADE ALIGNMENT)** procedure.

7. Lower blade guard and saw blade before reconnecting power source.

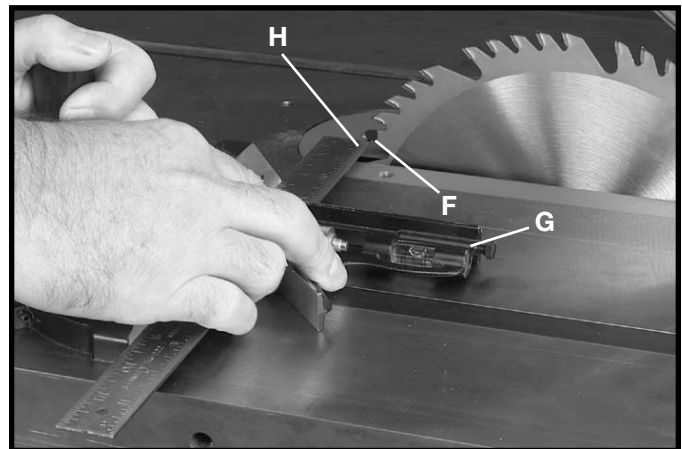

Fig. 101A



Fig. 101B

# ADJUSTING BLADE ALIGNMENT

**⚠ WARNING:** Blade Alignment is Factory Set and should not need adjustment. Adjusting Blade Alignment, in the field is a difficult and time-consuming procedure. All Saw Blades have some run-out. Therefore, re-adjusting blade alignment should only be attempted if it becomes necessary. (See step 6 in CHECKING BLADE ALIGNMENT.)

1. **⚠ WARNING:** Disconnect machine from power source.

2. Lower blade. Remove blade guard and table insert. With a 1/2" wrench, loosen the 4 front and rear trunnion mounting bolts (E) Fig. 101C. **NOTE:** Only the 2 rear trunnion mounting bolts are shown.

3. Move the trunnion assembly in the desired direction. Tap gently with rubber mallet if necessary.

4. To check blade alignment, follow (**CHECKING BLADE ALIGNMENT**) procedure until proper alignment is achieved. Tighten 4 trunnion bolts (E).

5. Check blade alignment again after tightening bolts to confirm alignment. If alignment is off, loosen the 4 trunnion bolts (E) and repeat the above steps until proper alignment is achieved with bolts fully tightened.

6. Install table insert, blade guard, and lower blade before reconnecting power source.

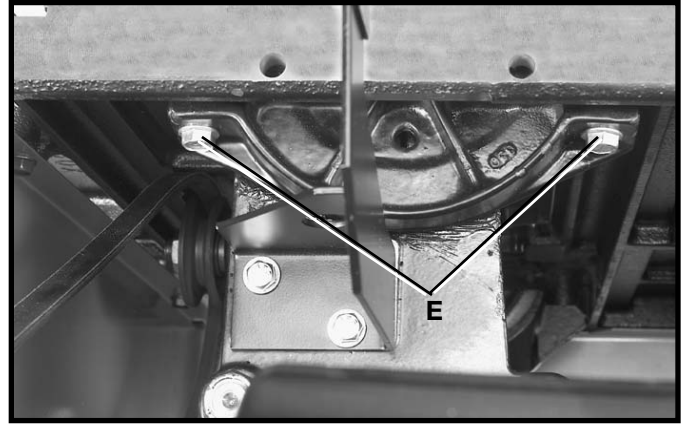

Fig. 101C

# MITER GAGE OPERATION AND ADJUSTMENT

1. Insert the miter gage bar into the miter gage slot and assemble the washer and lock handle (A) Fig. 102, to the miter gage bar. Insert cap (K) into top of handle (A).

2. The miter gage is equipped with adjustable index stops at 90 degrees and 45 degrees right and left. Adjustment to the index stops can be made by tightening or loosening the three adjusting screws (B) Fig. 103.

3. To rotate the miter gage, loosen lock knob (A) Fig. 103, and move the body of the miter gage (C) to the desired angle.

4. The miter gage body will stop at 90 degrees and 45 degrees both right and left. To rotate the miter gage body past these points, the stop link (D) Fig. 103, must be moved up and out of the way.

5. The head of the miter gage pivots on a special tapered screw (G) that fastens the head to the miter gage bar. If the miter gage head does not pivot freely, or pivots too freely, adjust it by loosening set screw (H) Fig. 104, and turning the screw (G), in or out. Be certain to tighten screw (H) after adjustment is made.

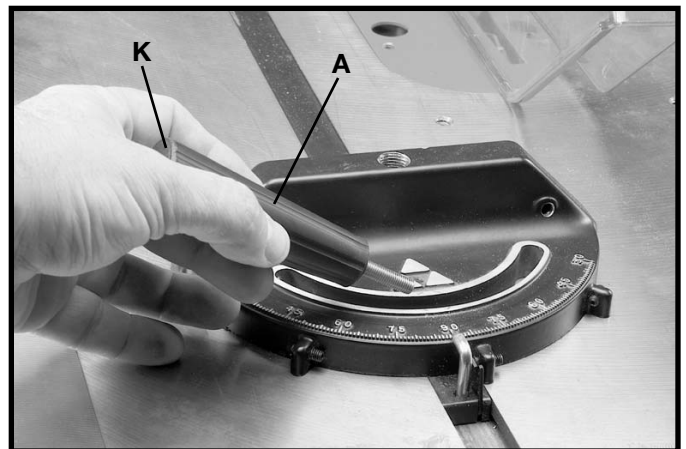

Fig. 102

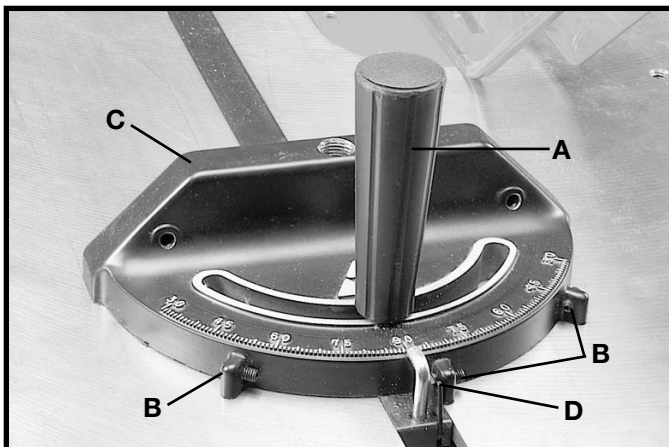

Fig. 103

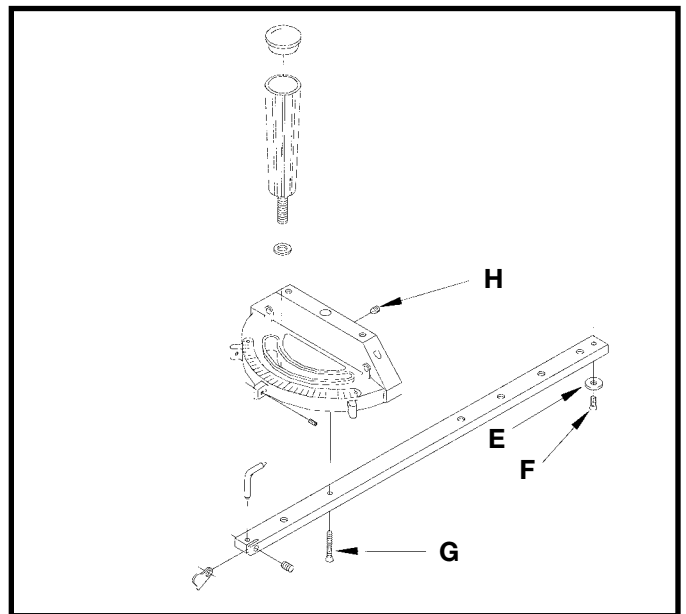

Fig. 104

## ADJUSTING TABLE INSERT

**⚠ WARNING: DISCONNECT MACHINE FROM POWER SOURCE.**

Place a straight edge across the table at both ends of the table insert (Fig. 105). The table insert (A) should always be level with the table. If an adjustment is necessary, turn the adjusting screws (B). Four adjusting screws (B) are supplied in the table insert. The table insert is equipped with a convenient finger hole (C) for easy removal.

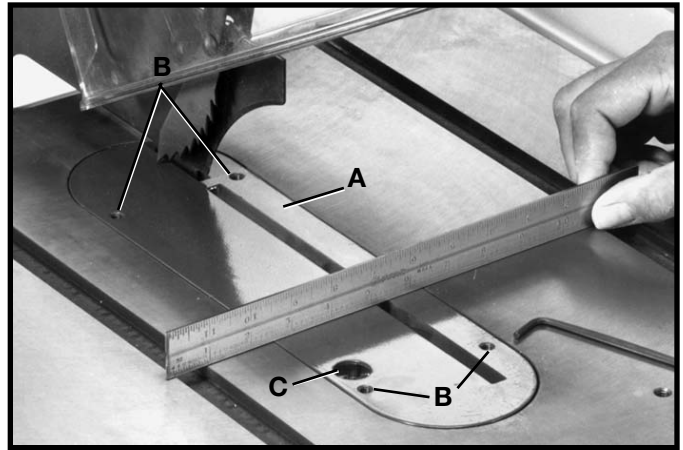

Fig. 105

## CHANGING THE SAW BLADE

1. **⚠ WARNING: DISCONNECT MACHINE FROM POWER SOURCE.**
2. **NOTE:** Two 7/8" wrenches are supplied with the saw for changing the saw blade: a box end wrench (A) Fig. 107, and open end wrench (B). Use only 10" saw blades rated for 3000 RPM or higher with 5/8" arbor holes.
3. Remove table insert (C) Fig. 106, and raise saw blade to its maximum height.
4. Place the open end wrench (B) Fig. 106 on the flats of the saw arbor to keep the arbor from turning, and use wrench (A), to turn the arbor nut toward the front of the saw. Remove arbor nut, blade flange, and saw blade.
5. Assemble the new blade, making certain the teeth point down at the front of the saw table, and assemble outside blade flange and arbor nut. With wrench (B) Fig. 106, on the flats of the arbor to keep it from turning, tighten arbor nut by turning wrench (A) counterclockwise.
6. Replace table insert.

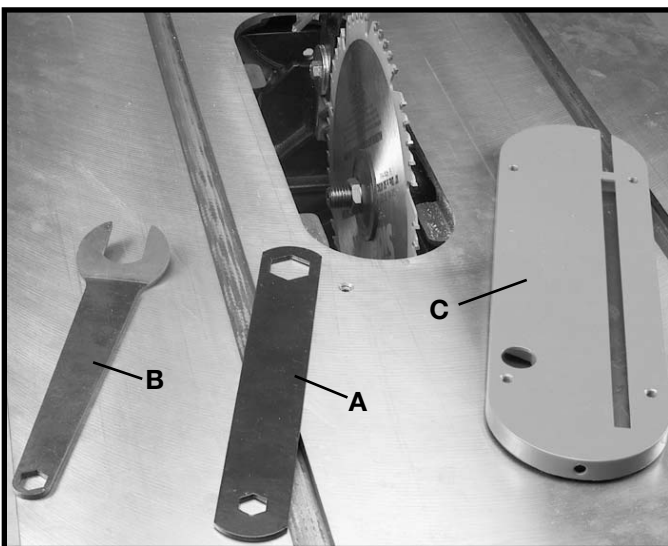

Fig. 106

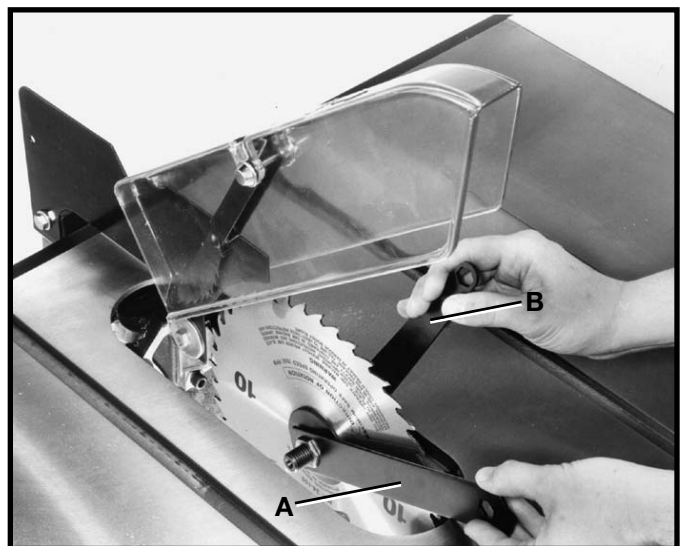

Fig. 107



# STORING THE MITER GAGE, RIP FENCE, AND ARBOR WRENCHES

1. When not in use, the miter gage (A) Fig. 108 can be stored through the hole located at the front side of the stand.
2. The rip fence (B) Fig. 108 can be conveniently stored out-of-the-way on the stamped ledges on the right side of the saw stand.
3. Arbor wrenches (C) Fig. 109, can be stored on one of the two notched legs.

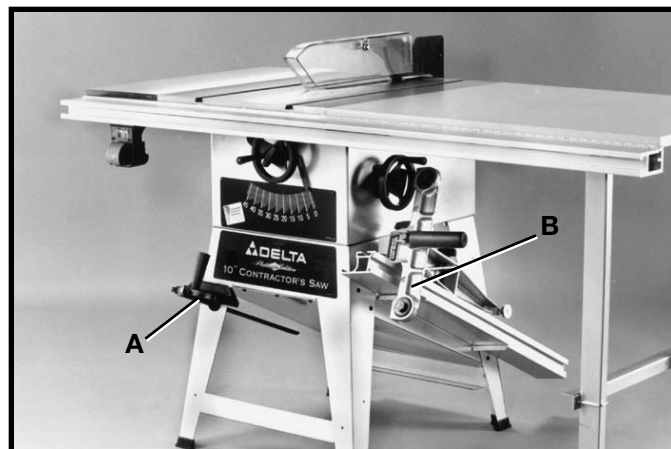

Fig. 108

## DUST CHUTE

The saw stand support panel (D) Fig. 109 also serves as a natural built-in dust chute. This dust chute (D) allows the sawdust to conveniently escape out the rear of the saw stand and away from the work area.

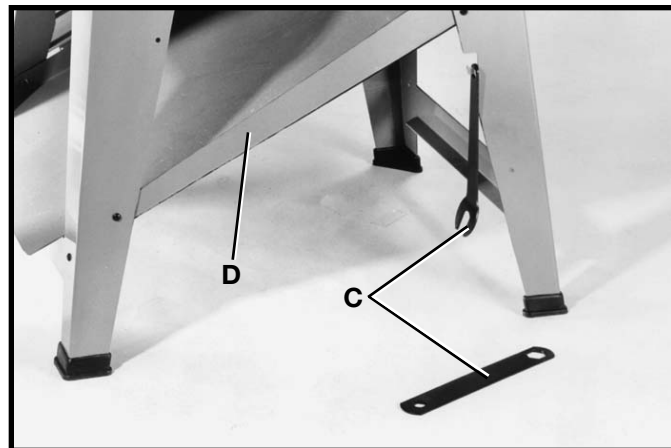

Fig. 109

## FENCE OPERATION

1. Before operating fence, make sure the fence is adjusted parallel to miter gage slot, as explained later on in this manual.
2. For most normal ripping operations of standard size lumber, the fence is used in the vertical position, as shown in (A) Fig. 110.
3. When ripping thin stock, use the fence in the horizontal position, (B) Fig. 111.

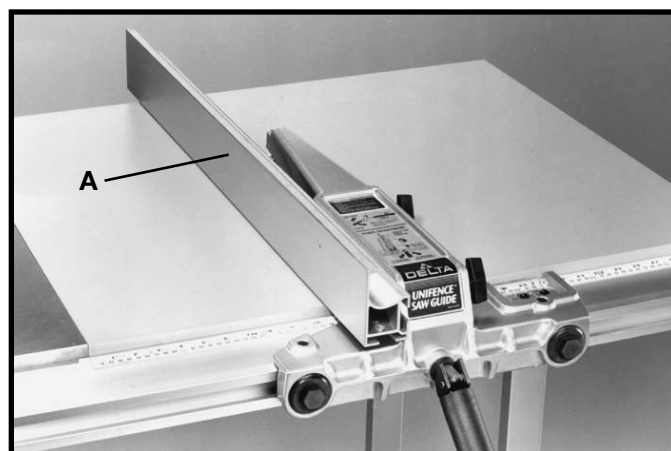

Fig. 110



Fig. 111



4. To move the fence along the guide rail, simply lift up clamp lever (A), Fig. 112, slide fence to desired position on the rail, and push down on clamp lever (A) to lock fence in place.

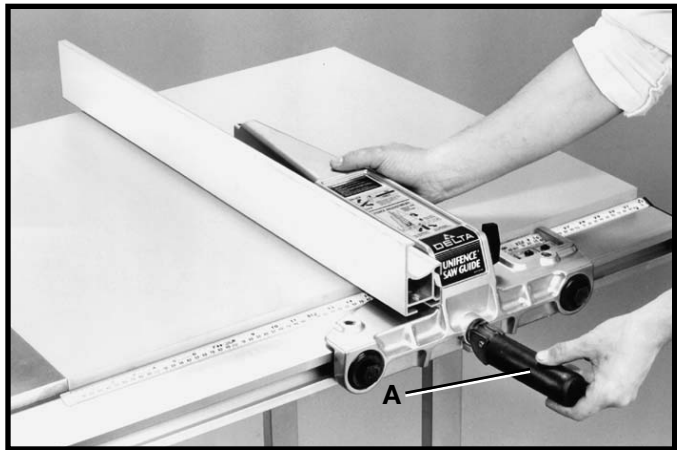

Fig. 112

5. The distance the fence is positioned away from the blade is indicated by the two witness lines (B) and (C) Fig. 113, located on the cursor (D). The witness lines (B) and (C) indicate the distance the fence is positioned away from the saw blade. Witness line (B) indicates the distance the fence is away from the blade when the fence is in the horizontal position (Fig. 111), and witness line (C) indicates the distance the fence is away from the blade when the fence is in the vertical position (Fig. 110). To adjust cursor (D), make a test cut with the fence in either the vertical or horizontal position, measure the distance of the finished cut and move the cursor (D) by loosening the two screws (E) Fig. 113. After adjustment is completed, tighten the two screws (E).

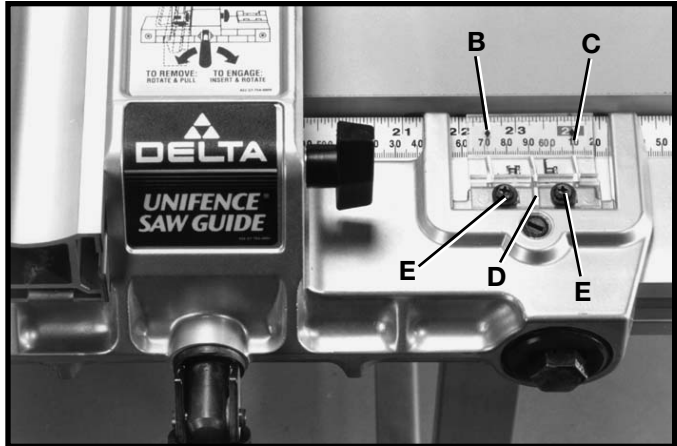

Fig. 113

6. To remove the fence and fence body assembly (F) Fig. 114, from the guide rail, lift up on fence clamping lever (A) and turn lever (A) to the CCW indent position. The fence assembly (F) can then be pulled straight off the guide rail and removed, as shown in Fig. 114.

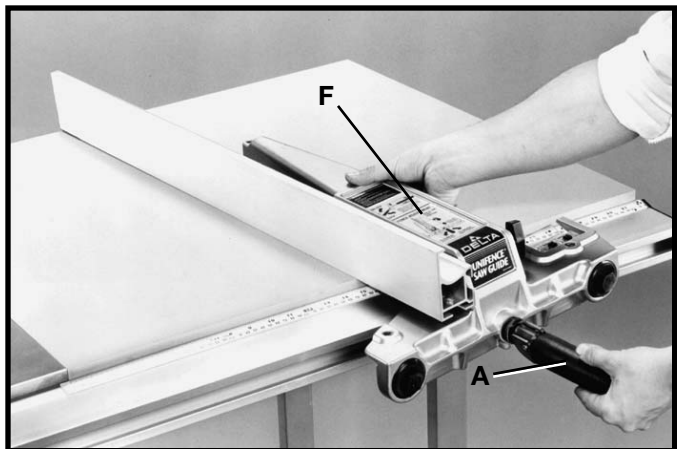

Fig. 114

## ADJUSTING FENCE PARALLEL TO MITER GAGE SLOTS

The fence (A) Fig. 115, should be adjusted so it is parallel to miter gage slots (B). To check and adjust, move the fence (A) until the bottom front edge of the fence is in line with the edge of the miter gage slot, and push down on fence clamping lever (C). Check to see that the fence is parallel to the miter gage slot the entire length of the table. If the rear of the fence must be moved, slightly tighten or loosen one of the adjustment plugs (D) or (E) Fig. 115, using the arbor wrench or 7/8" wrench, until the fence is parallel with the miter gage slot. **IMPORTANT: DO NOT OVERTIGHTEN ADJUSTMENT PLUGS (D) AND (E) FIG. 115. VERY LITTLE MOVEMENT OF THESE ADJUSTMENT PLUGS IS NECESSARY WHEN ADJUSTING THE FENCE PARALLEL WITH THE MITER GAGE SLOT.**

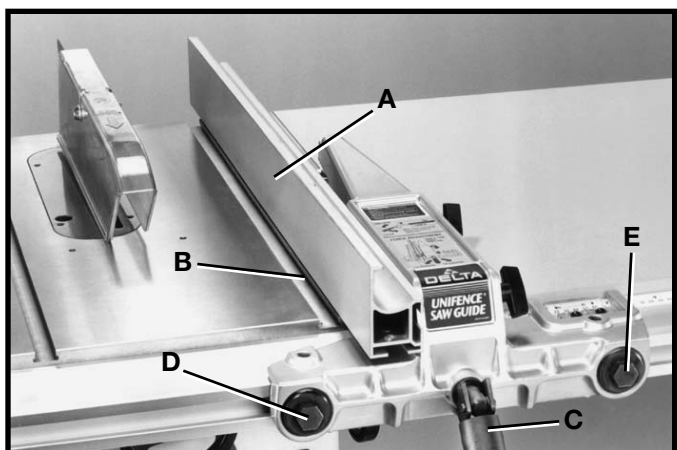

Fig. 115

## ADJUSTING FENCE 90 DEGREES TO TABLE

Adjust the fence so that the face of fence (A) Fig. 116 is 90 degrees to the table. To check if the fence is 90 degrees to the table, place a square (B) on the table with one end of the square against the fence. If an adjustment is necessary, tighten or loosen one of two screws (C) or (D) until the fence is 90 degrees to the table. **IMPORTANT: VERY LITTLE MOVEMENT OF THESE SCREWS (C) AND (D) IS NECESSARY TO MAKE THIS ADJUSTMENT.**

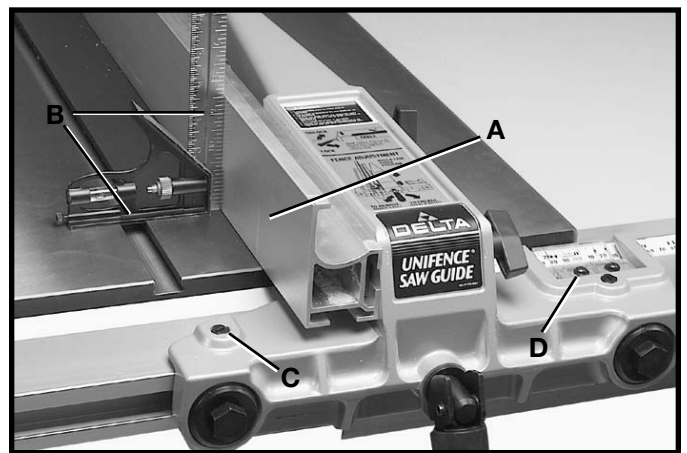

Fig. 116

## ADJUSTING CLAMPING ACTION OF FENCE LOCKING HANDLE

When the fence locking handle (A) is pushed to the down position (Fig. 117), the fence body (B) should be completely clamped to the guide rail. If the fence body (B) is not completely clamped to the guide rail when the handle (A) is in the position shown in Fig. 117, lift up the locking handle (A) Fig. 118, and slightly tighten two adjustment plugs (C) using arbor wrench or 7/8" wrench. Adjustment plugs (C) should be tightened an equal amount. Check to see if the fence body (B) is completely fastened to the rail by pushing down on locking lever (A). Adjust further if necessary.

**IMPORTANT: AFTER ADJUSTING THE CLAMPING ACTION OF THE FENCE LOCKING HANDLE, CHECK TO SEE IF THE FENCE IS PARALLEL TO THE MITER GAGE SLOT. ADJUST IF NECESSARY.**

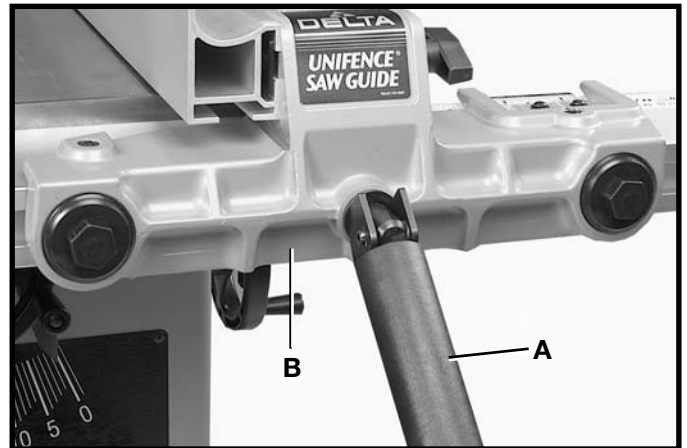

Fig. 117

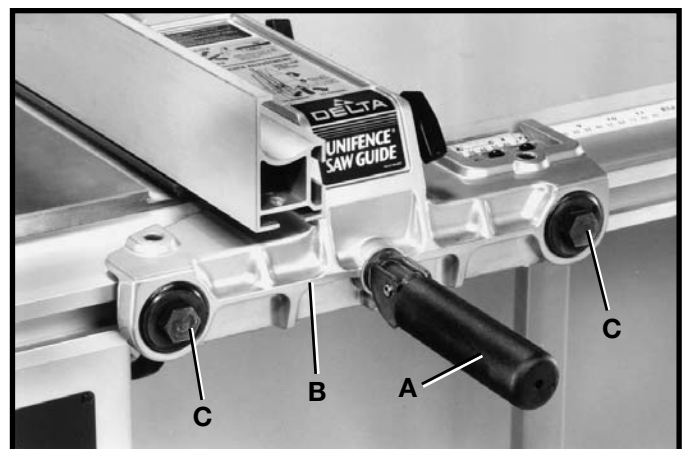

Fig. 118

## REPOSITIONING MOTOR FOR STORAGE

When the saw is not in use, the motor can be repositioned so that it hangs straight down at the rear, enabling you to move the saw against a wall. This can be accomplished by removing the belt and repositioning the motor and motor mounting plate, as shown in Fig. 119.

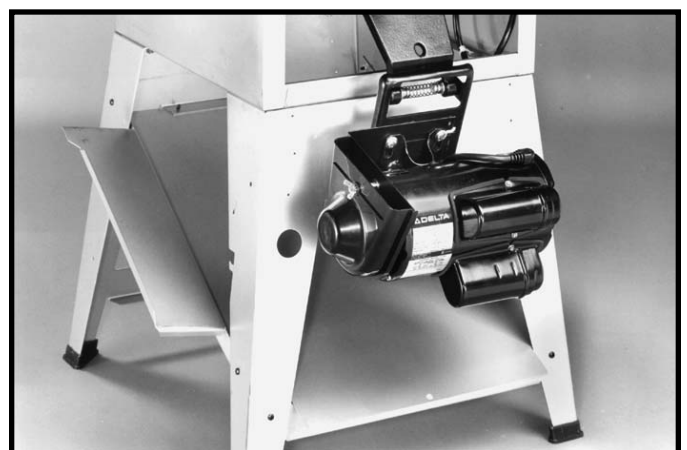

Fig. 119

# PROTECTING CAST IRON TABLE FROM RUST

To clean and protect cast iron tables from rust, you will need the following materials: 1 pushblock from a jointer, 1 sheet of medium Scotch-Brite™ Blending Hand Pad, 1 can of WD-40®, 1 can of degreaser, 1 can of TopCote® Aerosol. Apply the WD-40 and polish the table surface with the Scotch-Brite pad using the pushblock as a holddown. Degrease the table, then apply the TopCote® accordingly.

## COMMON SAWING OPERATIONS

Common sawing operations include ripping and cross-cutting, plus a few other standard operations of a fundamental nature. As with all power tools, there is a certain amount of hazard involved with the operation and use of the machine. Using the machine with the respect and caution, demanded as far as safety precautions are concerned, will considerably lessen the possibility of personal injury. However, if normal safety precautions are overlooked or completely ignored, personal injury to the operator can result.

**NOTE: THE USE OF ATTACHMENTS AND ACCESSORIES NOT RECOMMENDED BY DELTA MAY RESULT IN THE RISK OF INJURY.**

### CROSS-CUTTING

Cross-cutting requires the use of the miter gage to position and guide the work. Place the work against the miter gage and advance both the gage and work toward the saw blade, as shown in Fig. 120. The miter gage may be used in either table slot. When bevel cutting (blade tilted), use the table groove that does not cause interference of your hand or miter gage with the saw blade guard.

Start the cut slowly and hold the work firmly against the miter gage and the table. One of the rules in running a saw is that you never hang onto or touch a free piece of work. Hold the supported piece, not the free piece that is cut off. The feed in cross-cutting continues until the work is cut in two, and the miter gage and work are pulled back to the starting point. Before pulling the work back, it is good practice to give the work a little sideways shift to move the work slightly away from the saw blade. Never pick up any short length of free work from the table while the saw is running. Never touch a cut-off piece unless it is at least a foot long.

For added safety and convenience the miter gage can be fitted with an auxiliary wood-facing (C), as shown in Fig. 121, that should be at least 1 inch higher than the maximum depth of cut, and should extend out 12 inches or more to one side or the other depending on which miter gage slot is being used. This auxiliary wood-facing (C) can be fastened to the front of the miter gage by using two wood screws (A) through the holes provided in the miter gage body and into the wood-facing.



Fig. 120

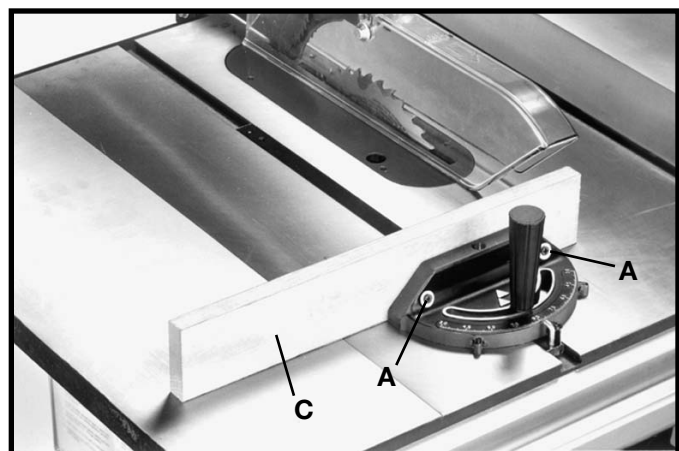

Fig. 121



**⚠ WARNING: NEVER USE THE BIESEMEYER FENCE SYSTEM AS A CUT-OFF GAGE WHEN CROSS-CUTTING WITHOUT USING (B) FIG. 121A.**

When cross-cutting a number of pieces to the same length, a block of wood (B) can be clamped to the fence and used as a cut-off gage as shown in Fig. 121A. It is important that this block of wood always be positioned in front of the saw blade as shown. Once the cut-off length is determined, secure the fence and use the miter gage to feed the work into the cut.

This block allows the cut-off piece to move freely along the table surface without binding between the fence and the saw blade, thereby eliminating the possibility of kickback and injury to the operator.

**IMPORTANT:** When using the block (B) Fig. 121A, as a cut-off gage, it is very important that the rear end of the block be positioned so the work piece is clear of the block before it enters the blade.

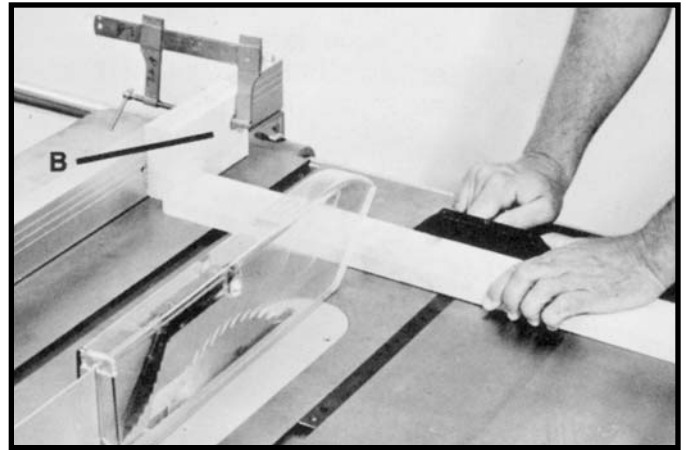

Fig. 121A

---

## FOR UNIFENCE SYSTEMS ONLY THE UNIFENCE CAN BE USED AS A CUT-OFF GAGE

The fence can be used as a cut-off gage when cross cutting a number of pieces to the same length.

**IMPORTANT: WHEN USING THE FENCE AS A CUT-OFF GAGE, IT IS VERY IMPORTANT THAT THE REAR END OF THE FENCE BE POSITIONED IN FRONT OF THE SAW BLADE.**

When using the fence as a cut-off gage, simply position the fence (A) to the front (Fig. 122), or purchase the accessory 12" long fence (B), Fig. 123. Fig. 124 illustrates a typical operation using the accessory 12" long fence (B) as a cut-off gage.

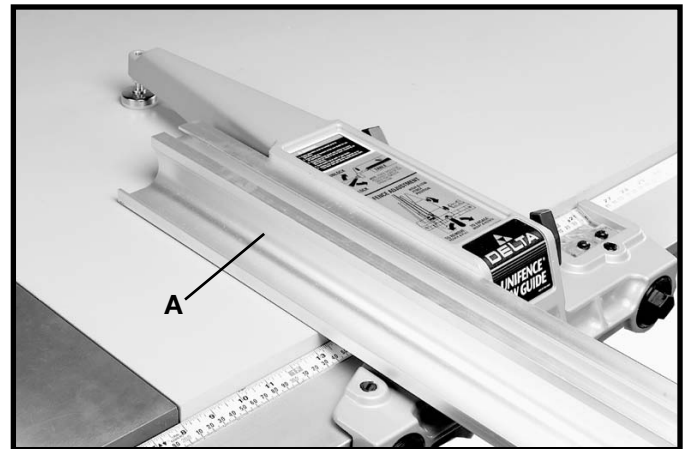

Fig. 122

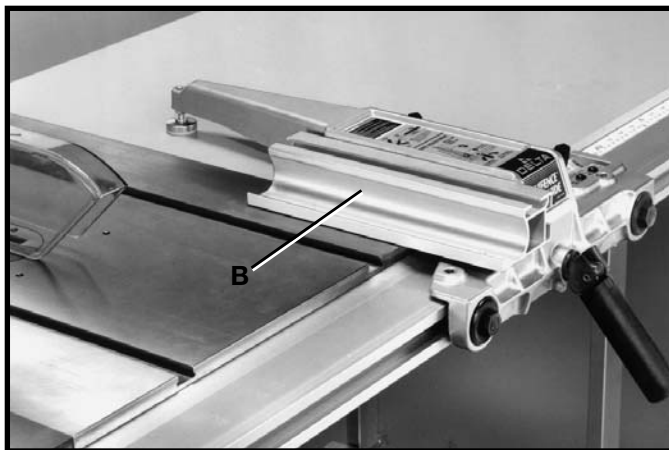

Fig. 123



Fig. 124



# RIPPING WITH THE UNIFENCE

Ripping is cutting lengthwise through a board, (Fig. 125). The rip fence (A) is used to position and guide the work. One edge of the work rides against the rip fence while the flat side of the board rests on the table. Since the work is pushed along the fence, it must have a straight edge and make solid contact with the table. The saw blade guard must be used. On Delta saws, the guard has anti-kickback fingers to prevent kickback and a splitter to prevent the wood kerf from closing and binding the blade.

1. Never stand in the line of the saw cut when ripping. Hold the work with both hands and push it along the fence and into the saw blade (Fig. 125). The work can then be fed through the saw blade with one or two hands. After the work is beyond the saw blade and anti-kickback fingers, the hand is removed from the work. When this is done the work will either stay on the table, tilt up slightly and be caught by the end of the rear guard, or slide off the table to the floor. Alternately, the feed can continue to the end of the table, after which the work is lifted and brought along the outside edge of the fence. The cut-off stock remains on the table and is not touched until the saw blade has stopped, unless it is a large piece allowing safe removal. When ripping boards longer than three feet, use a work support at the rear of the saw to keep the workpiece from falling off the saw table.

2. If the ripped work is less than 4 inches wide, a push stick should always be used to complete the feed, as shown in Fig. 126. The push stick can easily be made from scrap material as explained in the section **"CONSTRUCTING A PUSH STICK."**

3. Ripping narrow pieces can be dangerous if not done carefully. Narrow pieces usually cannot be cut with the guard in position. If the workpiece is short enough, use a pushboard. When ripping material under 2 inches in width, a flat pushboard is a valuable accessory since ordinary type sticks may interfere with the blade guard. When using a pushboard, the width of the pushboard must be added to the width of the rip fence position setting. A flat pushboard can be constructed as shown in Fig. 126A and should be used as shown in Fig. 126B.

**NOTE:** Some special operations (when using the moulding cutterhead) require the addition of an auxiliary wood facing to the fence, as explained in the section **"USING AUXILIARY WOOD FACING ON THE UNIFENCE"** and use of a push stick.



Fig. 125



Fig. 126

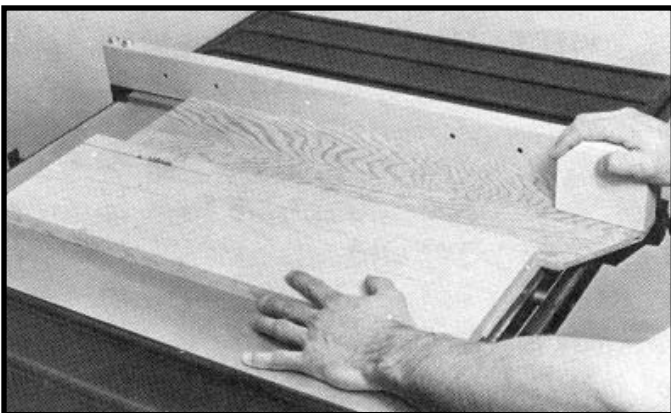

Fig. 126B

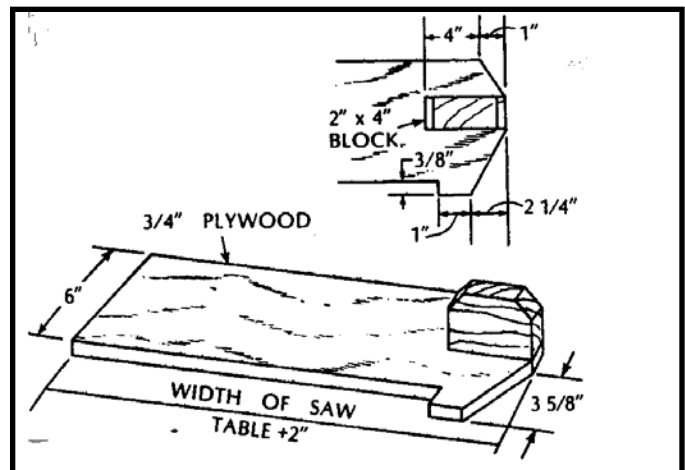

Fig. 126A

4. When ripping material with a veneer facing that extends over the material, the fence (A) should be in the horizontal position with the veneer (B) extending over the lip of the fence, (Fig. 127).

5. When ripping material with a veneer facing and the material is not thick enough for the veneer to extend over the lip of the fence, or if the veneer facing (B) is on both sides of the material, (Fig. 128), the fence can be positioned slightly above the surface of the table. The veneer can be placed between the fence and the table or the veneer can straddle the fence with the material solidly against the fence, as shown.



Fig. 127

## RIPPING ON LEFT SIDE OF SAW BLADE

In some cases, it may be desirable to use the fence on the left side of the saw blade. This action is easily accomplished by repositioning the fence (A) Figs. 129 and 130, fence clamp bar (B), and lock knobs (C) so that the fence (A) will be attached to the right side of the fence body, (Fig. 130). The complete fence assembly (D) Fig. 130 can easily be moved to the left side of the saw table.

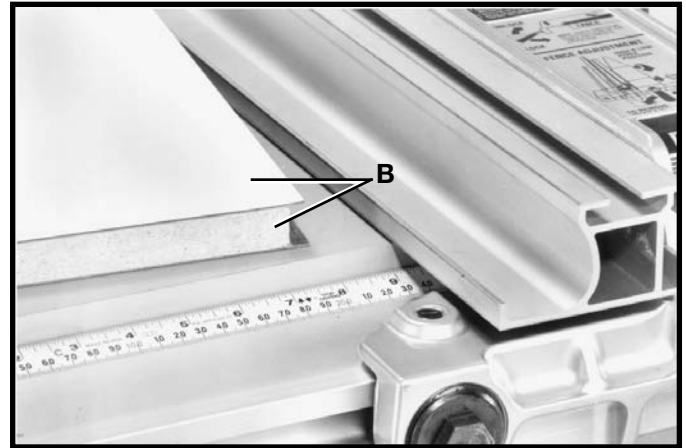

Fig. 128

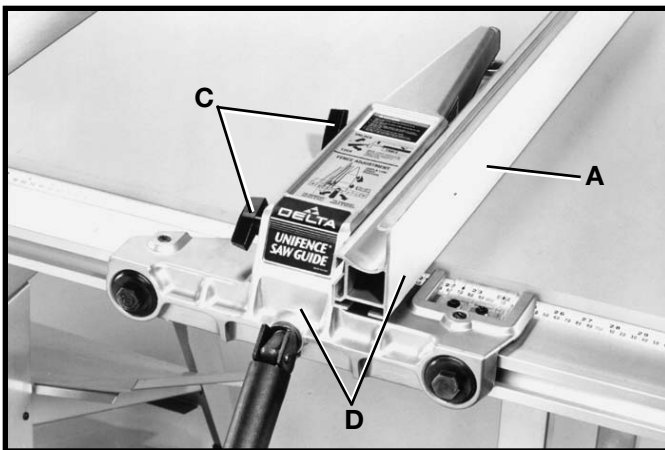

Fig. 130

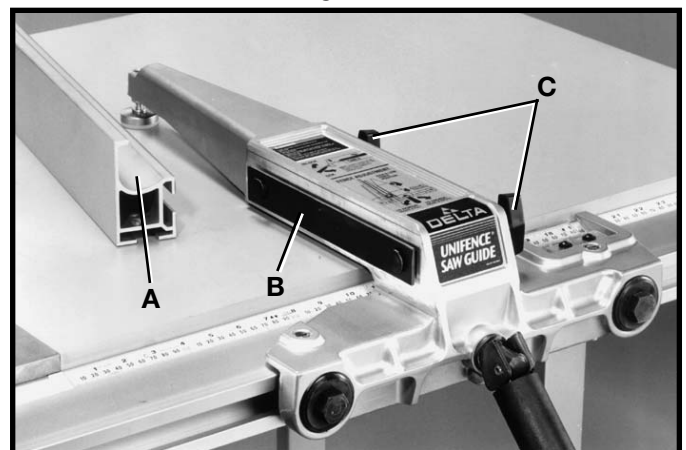

Fig. 129

## USING AUXILIARY WOOD FACING ON RIP FENCE

Some special operations (when using the moulding cutterhead) require the addition of a wood facing (A) Fig. 130A to one side of the rip fence. The wood facing is attached to the fence with wood screws through holes drilled in the fence. Stock that is 3/4 inch is suitable for most work, although an occasional job may require one-inch facing.

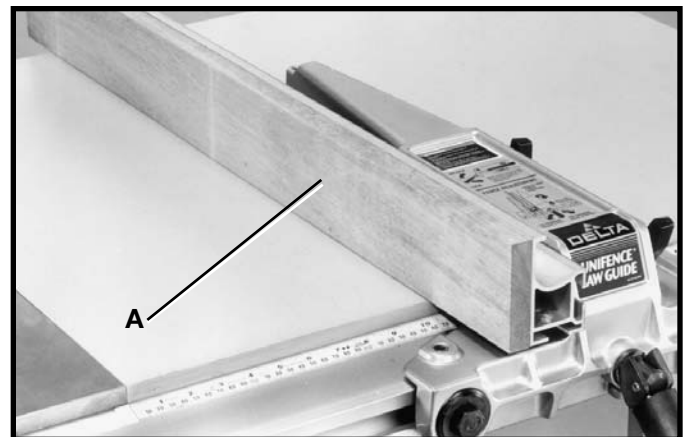

Fig. 130A



# USING ACCESSORY MOULDING CUTTERHEAD

Moulding is cutting a shape on the edge or face of the work. Cutting mouldings with a moulding cutterhead in the circular saw is a fast, safe and clean operation. The many different knife shapes available make it possible for the operator to produce almost any kind of mouldings, such as various styles of corner moulds, picture frames, table edges, etc.

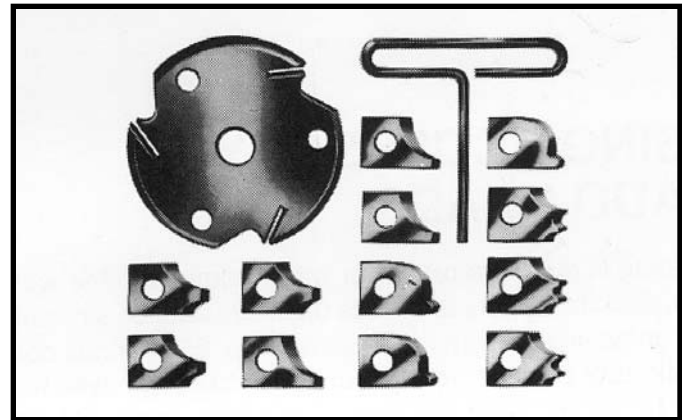

Fig. 131

The moulding head consists of a cutterhead in which can be mounted various shapes of steel knives, (Fig. 131). Each of the three knives in a set is fitted into a groove in the cutterhead and securely clamped with a screw. The knife grooves should be kept free of sawdust which would prevent the cutter from seating properly.

**IMPORTANT:** For certain cutting operations (dadoing and moulding) where the workpiece is not cut completely through, the blade guard and splitter assembly cannot be used. Loosen screws (G) and (H) Fig. 132. Lift up and swing blade guard and splitter assembly (W) Fig. 133 to the rear of the saw and retighten (H). **CAUTION:** Always return and fasten the blade guard and splitter assembly to its proper operating position for normal thru-sawing operations as shown in Fig. 32 and 33.



Fig. 132

A moulding cutterhead (A) Fig. 134 is shown assembled to the saw arbor. Also, the accessory moulding cutterhead table insert (B) must be used in place of the standard table insert.

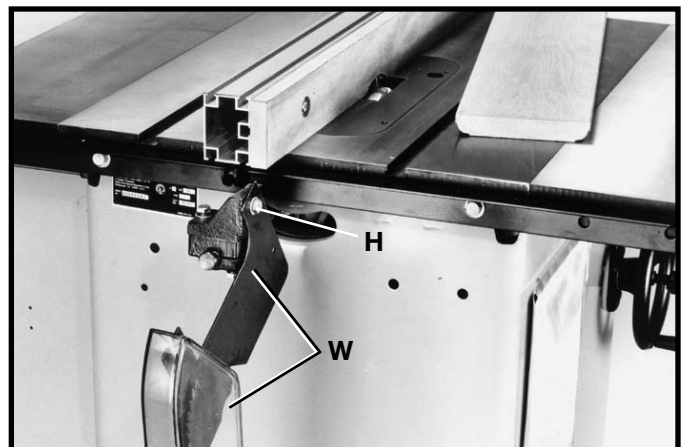

Fig. 133

When using the moulding cutterhead, add wood-facing (C) to the face of the rip fence (Fig. 135). The wood-facing is attached to the fence with wood screws through holes which must be drilled in the fence. Stock that is 3/4" inch thick is suitable for most work, although an occasional job may require 1 inch facing.

Position the wood-facing over the cutterhead with the cutterhead below the surface of the table. Turn the saw on and raise the cutterhead. The cutterhead will cut its own groove in the wood-facing. Fig. 135 shows a typical moulding operation. See accessories for molding cutterhead set. **NEVER USE MOULDING CUTTERHEAD IN A BEVEL POSITION.**

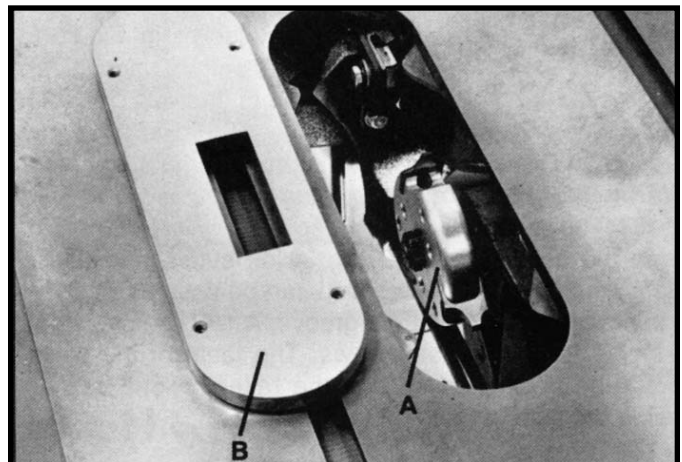

Fig. 134

**IMPORTANT: NEVER RUN THE STOCK BETWEEN THE FENCE AND THE MOULDING CUTTERHEAD. IRREGULAR SHAPED WOOD WILL CAUSE KICKBACK.**

**IMPORTANT: Special attention should be given the grain direction. Make all cuts in the same direction as the grain whenever possible.**

**⚠ WARNING: ALWAYS INSTALL BLADE GUARD AFTER OPERATION IS COMPLETE.**



Fig. 135

## USING ACCESSORY DADO HEAD

**IMPORTANT: THE BLADE GUARD AND SPLITTER ASSEMBLY CANNOT BE USED WHEN DADOING OR MOULDING. IT MUST BE REMOVED OR SWUNG TO THE REAR OF THE SAW AS DESCRIBED IN "USING ACCESSORY MOULDING CUTTERHEAD" SECTION.**

1. Dadoing is cutting a rabbet or wide groove into the work. Most dado head sets are made up of two outside saws and four or five inside cutters, (Fig. 136). Various combinations of saws and cutters are used to cut grooves from 1/8" to 13/16" for use in shelving, making joints, tenoning, grooving, etc. The cutters are heavily swaged and must be arranged so that this heavy portion falls in the gullets of the outside saws, as shown in Fig. 137. The saw and cutter overlap is shown in Fig. 138, (A) being the outside saw, (B) an inside cutter, and (C) a paper washer or washers, used as needed to control the exact width of groove. A 1/4" groove is cut by using the two outside saws. The teeth of the saws should be positioned so that the raker on one saw is beside the cutting teeth on the other saw.

2. Attach the dado head set (D) Fig. 139, to the saw arbor. **IMPORTANT:** The blade guard and splitter assembly cannot be used when dadoing and must be removed or swung to the rear of the saw as explained previously in this manual. Auxiliary jigs, fixtures, push sticks, and feather boards should also be used. Also, the accessory dado head table insert (E) Fig. 139, must be used in place of the standard table insert.

3. Fig. 140 shows a typical dado operation using the miter gage as a guide.

**⚠ WARNING: NEVER USE THE DADO HEAD IN A BEVEL POSITION.**

**⚠ WARNING: ALWAYS INSTALL BLADE GUARD AFTER OPERATION IS COMPLETED.**

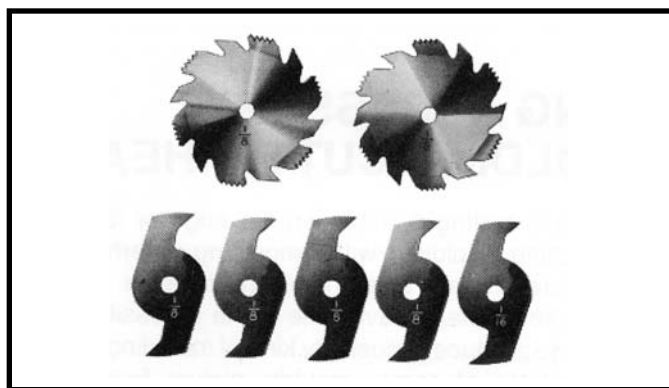

Fig. 136

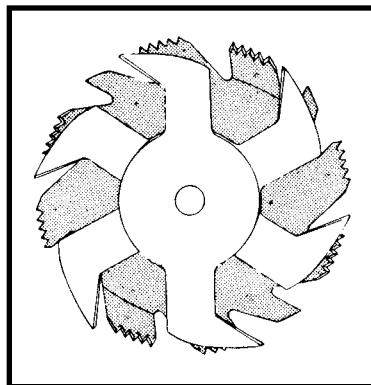

Fig. 137

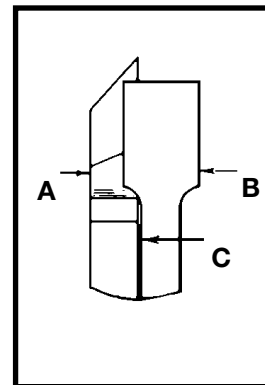

Fig. 138

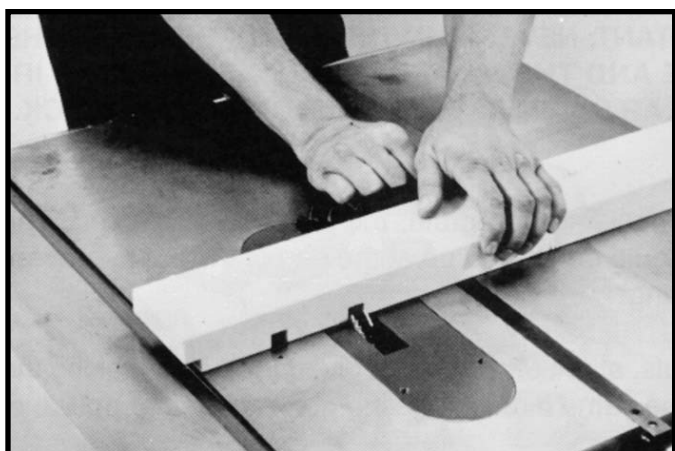

Fig. 140

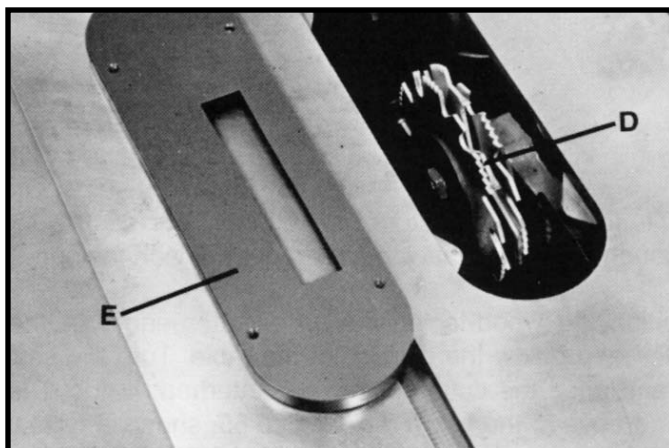

Fig. 139



# CONSTRUCTING A FEATHERBOARD

Fig. 141, illustrates dimensions for making a typical featherboard. The material which the featherboard is constructed of, should be a straight piece of wood that is free of knots and cracks. Featherboards are used to keep the work in contact with the fence and table, as shown in Fig. 141A, and help prevent kickbacks. Clamp the featherboards to the fence and table so that the leading edge of the featherboards will support the workpiece until the cut is completed. An 8" high flat board can be clamped to the rip fence and the featherboard can be clamped to the 8" high board. Use featherboards for all non "thru-sawing" operations where the guard and splitter assembly must be removed. Always replace the guard and splitter assembly when the non thru-sawing operation is completed.

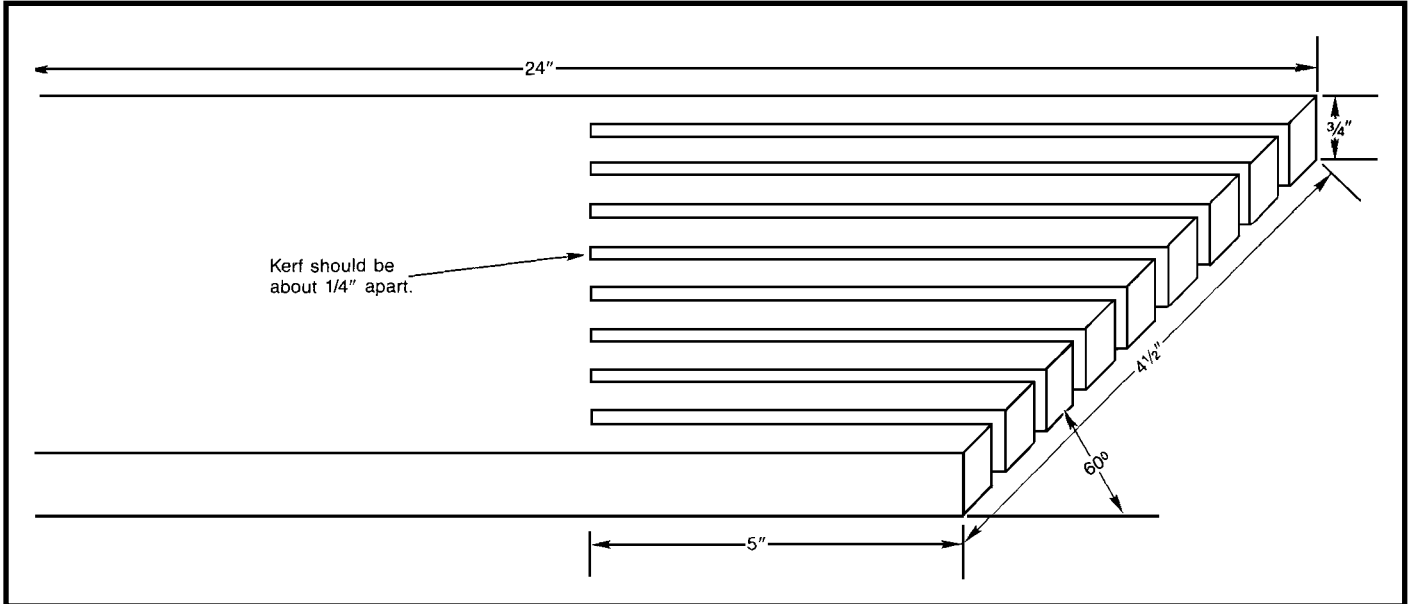

Fig. 141

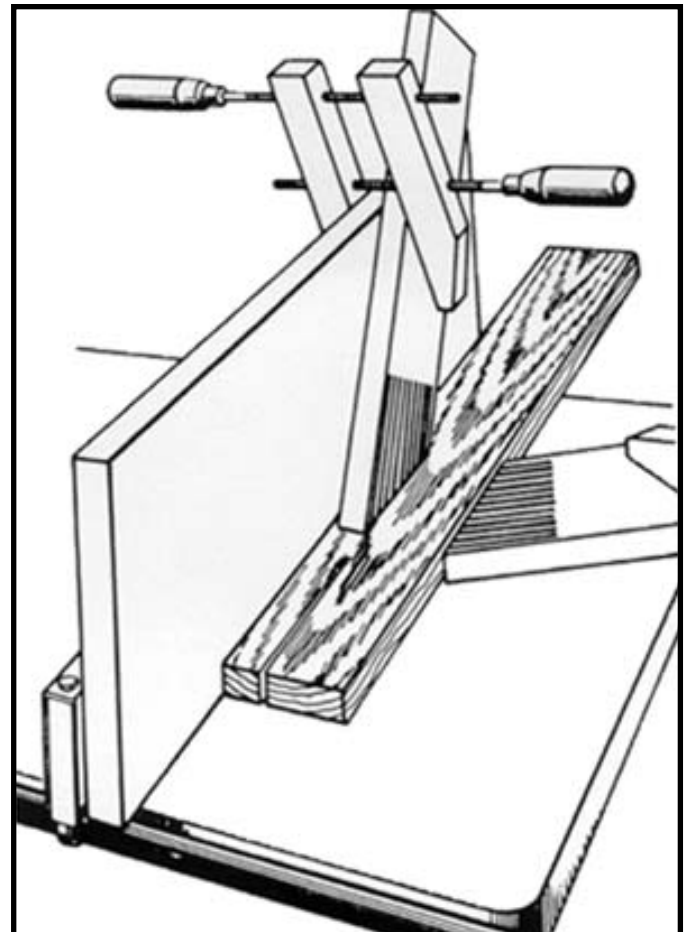

Fig. 141A

Further information on the safe and proper operation of table saws is available in the Delta "Getting the Most Out of Your Table Saw" How-To Book, Catalog No. 11-400. Additional Information on table saw safety is also available by writing to:

**NATIONAL SAFETY COUNCIL  
1121 SPRING LAKE DRIVE  
ITASCA, IL 60143-3201**

# BIESEMEYER T-SQUARE FENCE SYSTEM FENCE OPERATION

**IMPORTANT:** Before operating fence, make sure the fence is adjusted parallel to the miter gage slot, as explained later in this manual.



Fig. 142

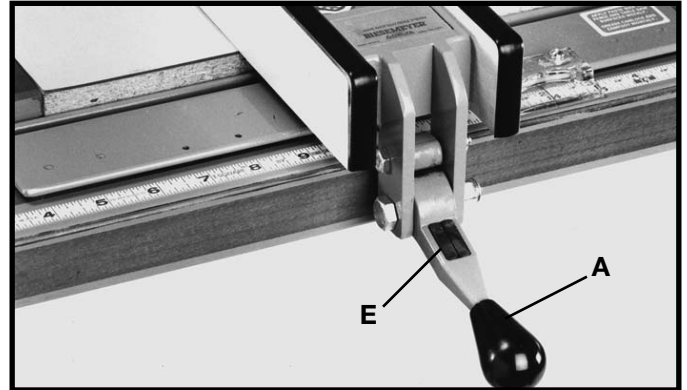

Fig. 143

1. To move the fence along the guide rail, simply lift up clamp lever (A) as shown in Fig. 142, slide fence to desired position on rail, and push down on clamp lever (A) as shown in Fig. 143. **NOTE:** A magnet (E) Fig. 143, is provided to hold clamp handle (A) Figs. 142 and 143, in the up position when moving the fence.

2. The distance the fence is positioned away from the blade is indicated by the witness line (B) Fig. 144, located on the cursor (C). To adjust the cursor (C), make a test cut with the fence locked in position. Measure the width of the finished cut and adjust the cursor (C) by loosening the two screws (D), adjusting the cursor (C) until the witness line (B) is aligned with the same marking on the scale as the finished cut. Tighten the two screws (D).

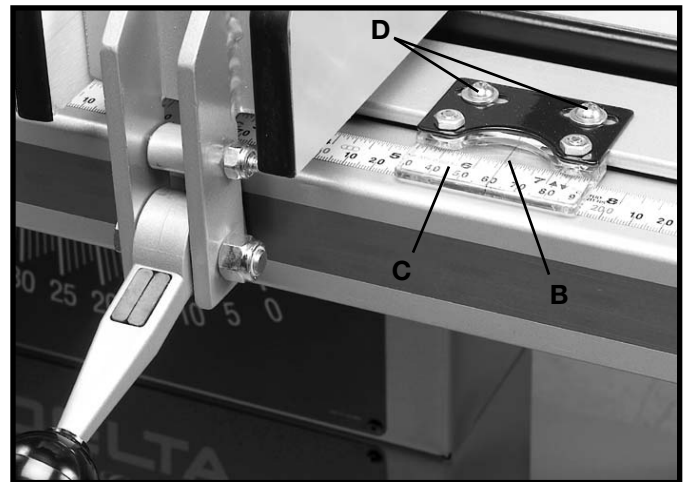

Fig. 144

## ADJUSTING FENCE PARALLEL TO MITER GAGE SLOTS

Adjust the fence (A) Fig. 145 so that it is parallel to the miter gage slots (B). To check and adjust, move fence (A) until the bottom edge of the fence is in line with the edge of one of the miter gage slots, and push down on the fence clamping lever (C). Check to see if the fence (A) is parallel to the miter gage slot the entire length of the table. If an adjustment must be made, lift up fence locking lever (C) and raise fence up off the guide tube, (Fig. 146). Tighten or loosen one of the two adjusting screws (D) or (E) Fig. 146, using a 3/16" allen wrench (F), not supplied. Replace the fence on the guide tube and check again to see if the edge of the fence is parallel with the miter gage slot along the entire length of the slot. Repeat this adjustment until the fence is parallel with the miter gage slot. **IMPORTANT: VERY LITTLE MOVEMENT OF SCREWS (D) AND (E) IS NECESSARY TO ADJUST THE FENCE PARALLEL WITH THE MITER GAGE SLOT.**

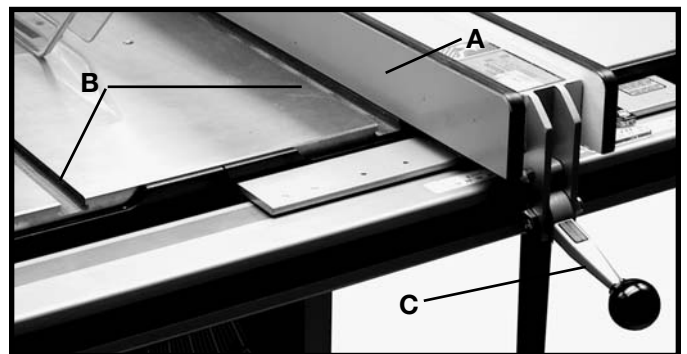

Fig. 145



Fig. 146

## ADJUSTING CLAMPING ACTION OF FENCE LOCKING HANDLE

When the fence locking handle (A) is pushed to the down position, (Fig. 147), the fence assembly (B) should be completely clamped to the guide tube (C). If the fence assembly (B) is not completely clamped to the guide tube (C) when the handle (A) is pushed down, as shown in Fig. 147, lift up handle (A) and raise fence assembly (B) up off the guide tube (C). Slightly tighten the two adjusting screws (D) and (E) Fig. 148, using the 3/16" allen wrench (F) not supplied. **Adjusting screws (D) and (E) Fig. 148, should be tightened an equal amount.** Replace fence onto the guide tube and re-check to see if the fence assembly (B) Fig. 147 is completely tightened to the guide tube (C) with the locking handle (A) pushed down. Adjust further if necessary. **IMPORTANT: AFTER ADJUSTING THE CLAMPING ACTION OF THE FENCE LOCKING HANDLE, CHECK TO SEE IF THE FENCE IS PARALLEL TO THE MITER GAGE SLOT AND ADJUST IF NECESSARY.**

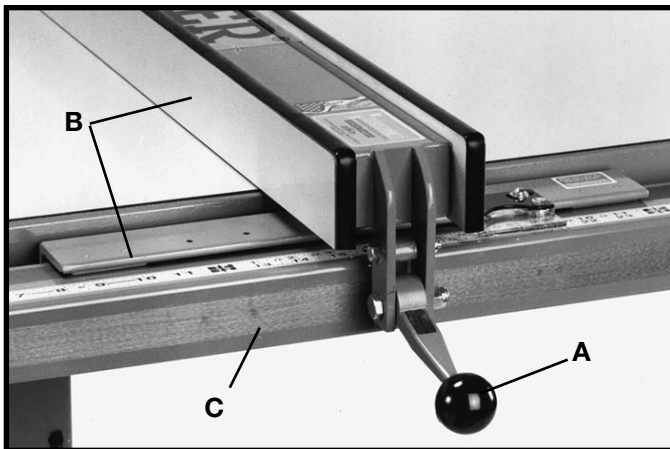

Fig. 147

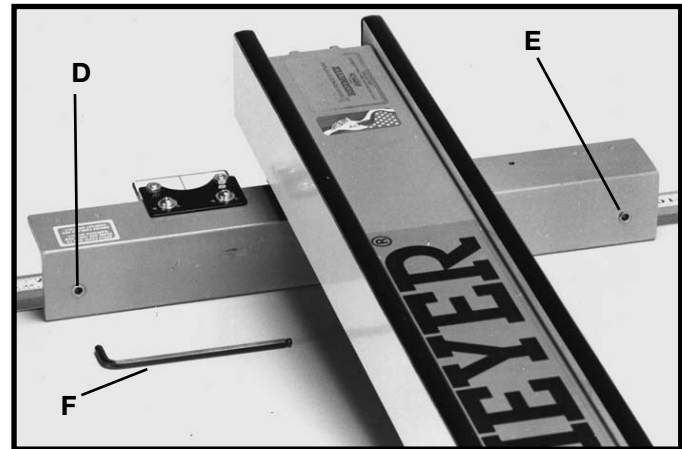

Fig. 148

## LUBRICATION

1. Apply household floor paste wax to fence and guide tube sliding surfaces weekly. Also, saw table and extension table surface should be waxed often.
2. Apply grease to cam lock (A) Fig. 149, and cam foot (B) occasionally to prevent wear.

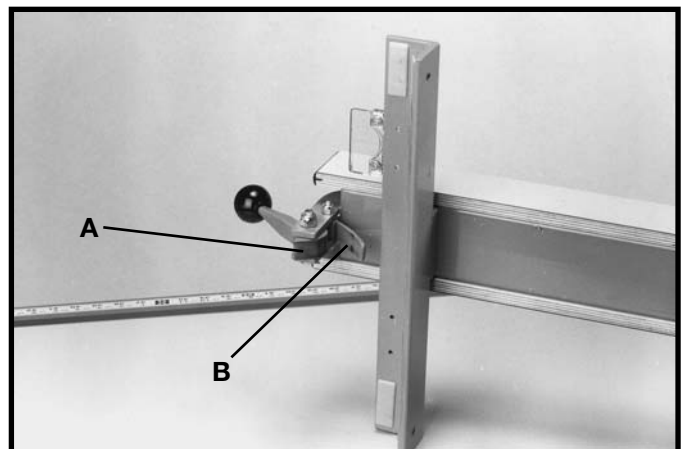

Fig. 149

# CONSTRUCTING A PUSH STICK

When ripping work less than 4 inches wide, a push stick should be used to complete the feed and could easily be made from scrap material by following the pattern shown in Fig. 150.

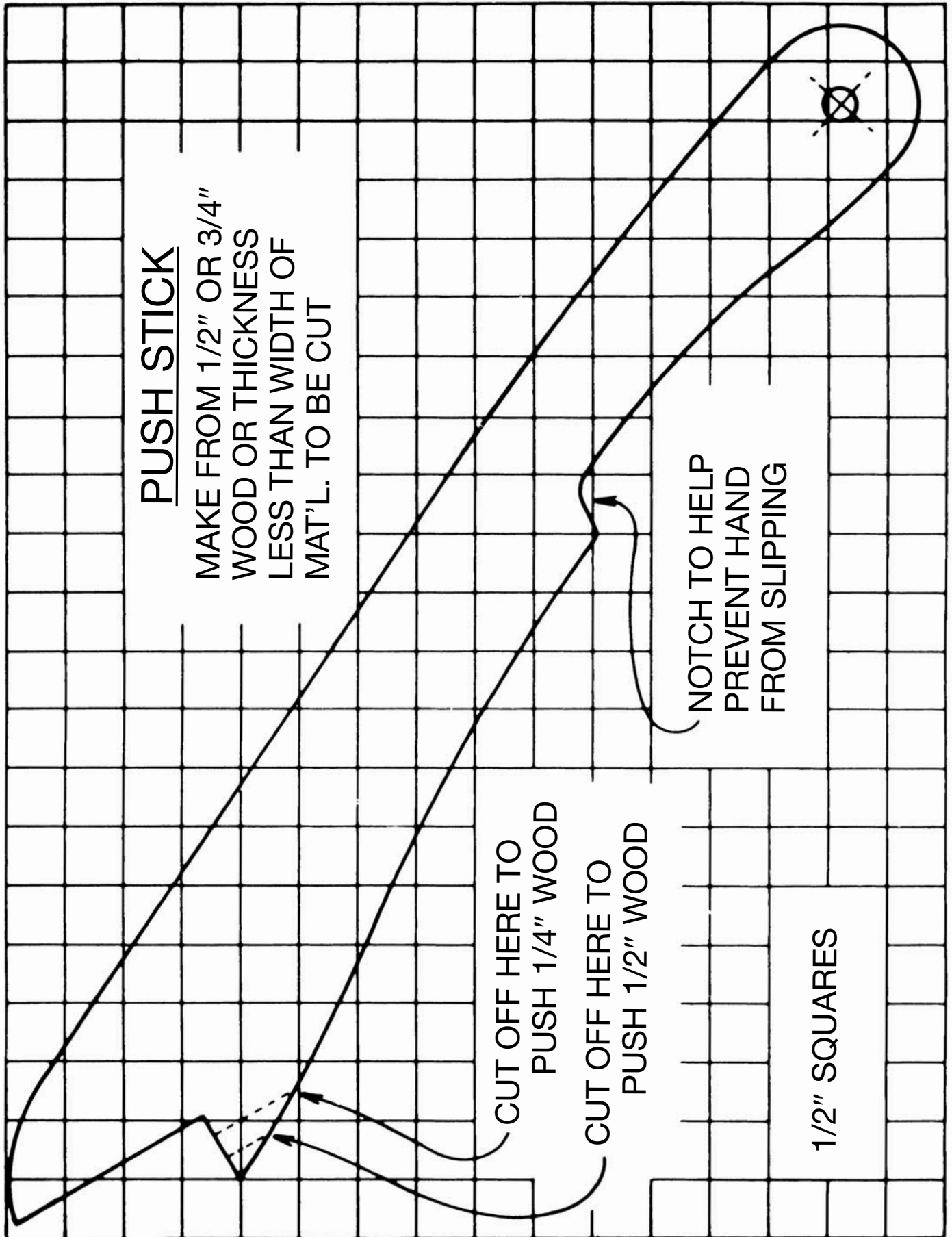

Fig. 150



# BLADE GUARD ACCESSORIES

## Deluxe Uniguard® Blade Guard

The Delta Model 34-976 Uniguard Blade Guard with Splitter and Anti-kickback Fingers Fig. 151, is an accessory that can be used in place of the standard blade guard that is supplied with the Contractor's Saw. The Delta Model 34-976 Uniguard Blade Guard can be mounted to the Contractor's Saw with a UniRip or Unifence, fence systems.

**78-953** Uniguard Strap Kit. Kit replaces the rear angle rail of Biesemeyer 30" and 50" Commercial Fence Systems and Home Shop Fence Systems up to 52" for mounting the No. 34-976 Delta Uniguard Blade Guard. Mounting hardware included.



Fig. 151

## Biesemeyer® T-Square® Table Saw Blade Guard System

The Biesemeyer Model 78-960 T-Square Table Saw Blade Guard System Fig. 152, is an accessory that can be used in place of the standard blade guard that is supplied with the Contractor's Saw.

### Catalog Listing Biesemeyer T-Square Blade Guard Systems

**78-960** 10" System for Home Shop 52" and Commercial 50" Fence Systems. With T-arm assembly, blade guard, splitter, installation bracket, mounting hardware and instruction manual.

**78-955** 10" System for Home Shop 28", 40" and Commercial 26", 30" and 38" Fence Systems. Same as 78-960 except for fence systems 40" and under.

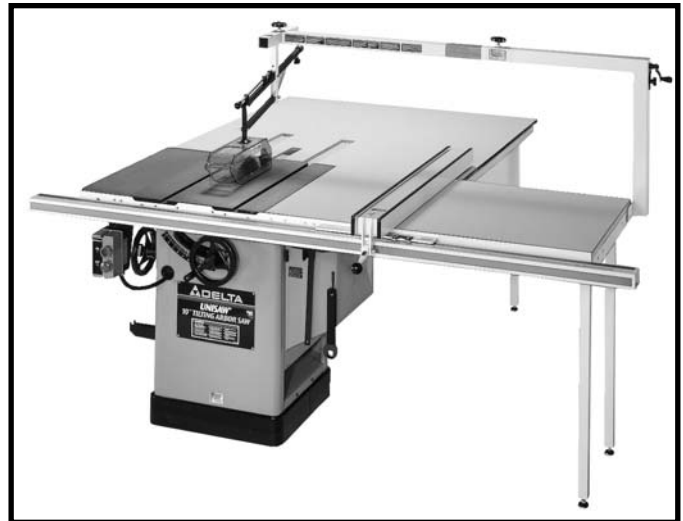

Fig. 152

# ACCESSORIES

A complete line of accessories is available from your Delta Supplier, Porter-Cable • Delta Factory Service Centers, and Delta Authorized Service Stations. Please visit our Web Site [www.deltamachinery.com](http://www.deltamachinery.com) for a catalog or for the name of your nearest supplier.



**WARNING:** Since accessories other than those offered by Delta have not been tested with this product, use of such accessories could be hazardous. For safest operation, only Delta recommended accessories should be used with this product.

<b>MODEL</b>	<b>DESCRIPTION</b>
34-976	Deluxe Uniguard Blade Guard
78-960	Biesemeyer T-Square Table Saw Blade Guard System



## PARTS, SERVICE OR WARRANTY ASSISTANCE

All Delta Machines and accessories are manufactured to high quality standards and are serviced by a network of Porter-Cable • Delta Factory Service Centers and Delta Authorized Service Stations. To obtain additional information regarding your Delta quality product or to obtain parts, service, warranty assistance, or the location of the nearest service outlet, please call 1-800-223-7278 (In Canada call 1-800-463-3582).



### Two Year Limited Warranty

Delta will repair or replace, at its expense and at its option, any Delta machine, machine part, or machine accessory which in normal use has proven to be defective in workmanship or material, provided that the customer returns the product prepaid to a Delta factory service center or authorized service station with proof of purchase of the product within two years and provides Delta with reasonable opportunity to verify the alleged defect by inspection. Delta may require that electric motors be returned prepaid to a motor manufacturer's authorized station for inspection and repair or replacement. Delta will not be responsible for any asserted defect which has resulted from normal wear, misuse, abuse or repair or alteration made or specifically authorized by anyone other than an authorized Delta service facility or representative. Under no circumstances will Delta be liable for incidental or consequential damages resulting from defective products. This warranty is Delta's sole warranty and sets forth the customer's exclusive remedy, with respect to defective products; all other warranties, express or implied, whether of merchantability, fitness for purpose, or otherwise, are expressly disclaimed by Delta.

# NOTES

# NOTES



## PORTER-CABLE • DELTA SERVICE CENTERS (CENTROS DE SERVICIO DE PORTER-CABLE • DELTA)

Parts and Repair Service for Porter-Cable • Delta Machinery are Available at These Locations  
(Obtenga Refaccion de Partes o Servicio para su Herramienta en los Siguientes Centros de Porter-Cable • Delta)

### ARIZONA

Tempe 85282 (Phoenix)  
2400 West Southern Avenue  
Suite 105  
Phone: (602) 437-1200  
Fax: (602) 437-2200

### CALIFORNIA

Ontario 91761 (Los Angeles)  
3949A East Guasti Road  
Phone: (909) 390-5555  
Fax: (909) 390-5554  
San Leandro 94577 (Oakland)  
3039 Teagarden Street  
Phone: (510) 357-9762  
Fax: (510) 357-7939

### COLORADO

Arvada 80003 (Denver)  
8175 Sheridan Blvd., Unit S  
Phone: (303) 487-1809  
Fax: (303) 487-1868

### FLORIDA

Davie 33314 (Miami)  
4343 South State Rd. 7 (441)  
Unit #107  
Phone: (954) 321-6635  
Fax: (954) 321-6638  
Tampa 33609  
4538 W. Kennedy Boulevard  
Phone: (813) 877-9585  
Fax: (813) 289-7948

### GEORGIA

Forest Park 30297 (Atlanta)  
5442 Frontage Road,  
Suite 112  
Phone: (404) 608-0006  
Fax: (404) 608-1123

### ILLINOIS

Addison 60101 (Chicago)  
400 South Rohlwing Rd.  
Phone: (630) 424-8805  
Fax: (630) 424-8895  
Woodridge 60517 (Chicago)  
2033 West 75th Street  
Phone: (630) 910-9200  
Fax: (630) 910-0360

### MARYLAND

Elkridge 21075 (Baltimore)  
7397-102 Washington Blvd.  
Phone: (410) 799-9394  
Fax: (410) 799-9398

### MASSACHUSETTS

Braintree 02185 (Boston)  
719 Granite Street  
Phone: (781) 848-9810  
Fax: (781) 848-6759  
Franklin 02038 (Boston)  
Franklin Industrial Park  
101E Constitution Blvd.  
Phone: (508) 520-8802  
Fax: (508) 528-8089

### MICHIGAN

Madison Heights 48071 (Detroit)  
30475 Stephenson Highway  
Phone: (248) 597-5000  
Fax: (248) 597-5004

### MINNESOTA

Minneapolis 55429  
5522 Lakeland Avenue North  
Phone: (763) 561-9080  
Fax: (763) 561-0653

### MISSOURI

North Kansas City 64116  
1141 Swift Avenue  
P.O. Box 12393  
Phone: (816) 221-2070  
Fax: (816) 221-2897  
St. Louis 63119  
7574 Watson Road  
Phone: (314) 968-8950  
Fax: (314) 968-2790

### NEW YORK

Flushing 11365-1595 (N.Y.C.)  
175-25 Horace Harding Expwy.  
Phone: (718) 225-2040  
Fax: (718) 423-9619

### NORTH CAROLINA

Charlotte 28270  
9129 Monroe Road, Suite 115  
Phone: (704) 841-1176  
Fax: (704) 708-4625

### OHIO

Columbus 43214  
4560 Indianola Avenue  
Phone: (614) 263-0929  
Fax: (614) 263-1238

Cleveland 44125  
8001 Sweet Valley Drive  
Unit #19  
Phone: (216) 447-9030  
Fax: (216) 447-3097

### OREGON

Portland 97230  
4916 NE 122 nd Ave.  
Phone: (503) 252-0107  
Fax: (503) 252-2123

### PENNSYLVANIA

Willow Grove 19090  
520 North York Road  
Phone: (215) 658-1430  
Fax: (215) 658-1433

### TEXAS

Carrlton 75006 (Dallas)  
1300 Interstate 35 N, Suite 112  
Phone: (972) 446-2996  
Fax: (972) 446-8157

Houston 77055  
West 10 Business Center  
1008 Wirt Road, Suite 120  
Phone: (713) 682-0334  
Fax: (713) 682-4867

### WASHINGTON

Auburn 98001 (Seattle)  
3320 West Valley HWY, North  
Building D, Suite 111  
Phone: (253) 333-8353  
Fax: (253) 333-9613

Authorized Service Stations are located in many large cities. Telephone **800-438-2486** or **731-541-6042** for assistance locating one. Parts and accessories for Porter-Cable-Delta products should be obtained by contacting any Porter-Cable-Delta Distributor, Authorized Service Center, or Porter-Cable-Delta Factory Service Center. If you do not have access to any of these, call **800-223-7278** and you will be directed to the nearest Porter-Cable-Delta Factory Service Center. Las Estaciones de Servicio Autorizadas están ubicadas en muchas grandes ciudades. Llame al **800-438-2486** ó al **731-541-6042** para obtener asistencia a fin de localizar una. Las piezas y los accesorios para los productos Porter-Cable-Delta deben obtenerse poniéndose en contacto con cualquier distribuidor Porter-Cable-Delta, Centro de Servicio Autorizado o Centro de Servicio de Fábrica Porter-Cable-Delta. Si no tiene acceso a ninguna de estas opciones, llame al **800-223-7278** y le dirigirán al Centro de Servicio de Fábrica Porter-Cable-Delta más cercano.

## CANADIAN PORTER-CABLE • DELTA SERVICE CENTERS

### ALBERTA

Bay 6, 2520-23rd St. N.E.  
Calgary, Alberta  
T2E 8L2  
Phone: (403) 735-6166  
Fax: (403) 735-6144

### BRITISH COLUMBIA

8520 Baxter Place  
Burnaby, B.C.  
V5A 4T8  
Phone: (604) 420-0102  
Fax: (604) 420-3522

### MANITOBA

1699 Dublin Avenue  
Winnipeg, Manitoba  
R3H 0H2  
Phone: (204) 633-9259  
Fax: (204) 632-1976

### ONTARIO

505 Southgate Drive  
Guelph, Ontario  
N1H 6M7  
Phone: (519) 836-2840  
Fax: (519) 767-4131

### QUÉBEC

1515 ave.  
St-Jean Baptiste,  
Québec, Québec  
G2E 5E2  
Phone: (418) 877-7112  
Fax: (418) 877-7123

1447, Begin  
St-Laurent, (Montréal),  
Québec  
H4R 1V8  
Phone: (514) 336-8772  
Fax: (514) 336-3505

The following are trademarks of PORTER-CABLE-DELTA (Las siguientes son marcas registradas de PORTER-CABLE S.A.): BAMMER®, INNOVATION THAT WORKS®, JETSTREAM®, LASERLOC®, OMNIGIG®, POCKET CUTTER®, PORTA-BAND®, PORTA-PLANE®, PORTER-CABLE®, QUICKSAND®, SANDTRAP®, SAW BOSS®, SPEED-BLOC®, SPEEDMATIC®, SPEEDTRONIC®, STAIR-EASE®, THE PROFESSIONAL EDGE®, THE PROFESSIONAL SELECT®, TIGER CUB®, TIGER SAW®, TORQBUSTER®, WHISPER SERIES®, DURATRONIC™, FLEX™, FRAME SAW™, MICRO-SET™, MORTEN™, NETWORK™, RIPTIDE™, TRU-MATCH™, WOODWORKER'S CHOICE™, THE AMERICAN WOOD SHOP™ (design), AUTO-SET™, B.O.S.S.™, BUILDER'S SAW™, CONTRACTOR'S SAW™, DELTA™, DELTACRAFT™, HOMECRAFT™, JET-LOCK™, KICKSTAND™, THE LUMBER COMPANY™ (design), MICRO-SET™, Q3™, QUICKSET II™, QUICKSET PLUS™, SAFEGUARD II™, SANDING CENTER™, SIDEKICK™, UNIFENCE™, UNIGUARD™, UNIRIP™, UNISAW™, VERSA-FEEDER™, THIN-LINE™, TPS™, Emc<sup>2</sup>™.

Trademarks noted with ™ and © are registered in the United States Patent and Trademark Office and may also be registered in other countries. Las Marcas Registradas con el signo de ™ y © son registradas por la Oficina de Registros y Patentes de los Estados Unidos y también pueden estar registradas en otros países.

Printed in U.S.A.

## Free Manuals Download Website

<http://myh66.com>

<http://usermanuals.us>

<http://www.somanuals.com>

<http://www.4manuals.cc>

<http://www.manual-lib.com>

<http://www.404manual.com>

<http://www.luxmanual.com>

<http://aubethermostatmanual.com>

Golf course search by state

<http://golfingnear.com>

Email search by domain

<http://emailbydomain.com>

Auto manuals search

<http://auto.somanuals.com>

TV manuals search

<http://tv.somanuals.com>