

*Comfort Glow*<sup>®</sup>

# UNVENTED (VENT-FREE) FIREPLACE OWNER'S OPERATION AND INSTALLATION MANUAL

For more information, visit [www.desatech.com](http://www.desatech.com)

**CF26PT**  
**CF26NT**

19,000 to 26,000 Btu/Hr  
with Thermostat

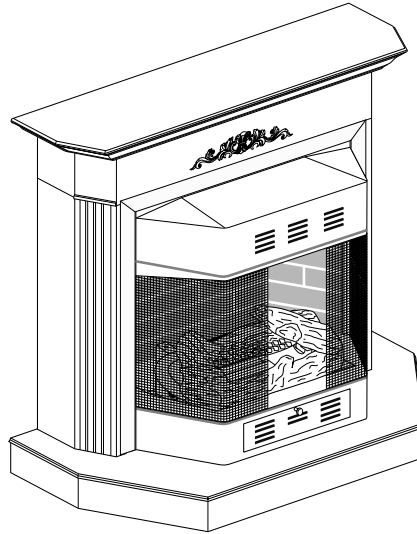

Patent Pending

Fireplace Shown With Optional  
Bay Front Mantel

## BAY FRONT PROPANE/LP AND NATURAL GAS FIREPLACE MODELS

**WARNING:** If the information in this manual is not followed exactly, a fire or explosion may result causing property damage, personal injury, or loss of life.

- Do not store or use gasoline or other flammable vapors and liquids in the vicinity of this or any other appliance.
- **WHAT TO DO IF YOU SMELL GAS**
  - Do not try to light any appliance.
  - Do not touch any electrical switch; do not use any phone in your building.
  - Immediately call your gas supplier from a neighbor's phone. Follow the gas supplier's instructions.
  - If you cannot reach your gas supplier, call the fire department.
- Installation and service must be performed by a qualified installer, service agency, or the gas

**WARNING:** Improper installation, adjustment, alteration, service, or maintenance can cause injury or property damage. Refer to this manual for correct installation and operational procedures. For assistance or additional information consult a qualified installer, service agency, or the gas supplier.

**WARNING:** This is an unvented gas-fired heater. It uses air (oxygen) from the room in which it is installed. Provisions for adequate combustion and ventilation air must be provided. Refer to *Air for Combustion and Ventilation* section on page 4 of this manual.

This appliance may be installed in an aftermarket,\* permanently located, manufactured (mobile) home, where not prohibited by local codes.

This appliance is only for use with type of gas indicated on the rating plate. This appliance is not convertible for use with other gases.

\* Aftermarket: Completion of sale, not for purpose of resale, from the manufacturer

Save this manual for future reference.

**DESA**

## TABLE OF CONTENTS

SAFETY INFORMATION .....	2	SPECIFICATIONS .....	18
PRODUCT IDENTIFICATION .....	3	SERVICE HINTS .....	18
LOCAL CODES .....	4	TECHNICAL SERVICE .....	18
UNPACKING .....	4	TROUBLESHOOTING .....	19
PRODUCT FEATURES .....	4	ILLUSTRATED PARTS BREAKDOWN AND PARTS LIST .....	22
AIR FOR COMBUSTION AND VENTILATION .....	4	REPLACEMENT PARTS .....	26
INSTALLATION .....	6	PARTS CENTRALS .....	26
OPERATING FIREPLACE .....	16	OWNER'S REGISTRATION FORM .....	27
INSPECTING BURNERS .....	17	ACCESSORIES .....	29
CLEANING AND MAINTENANCE .....	17	WARRANTY INFORMATION .....	30

## SAFETY INFORMATION

### WARNINGS

**⚠ WARNING:** This product contains and/or generates chemicals known to the State of California to cause cancer or birth defects, or other reproductive harm.

**IMPORTANT:** Read this owner's manual carefully and completely before trying to assemble, operate, or service this fireplace. Improper use of this fireplace can cause serious injury or death from burns, fire, explosion, electrical shock, and carbon monoxide poisoning.

**⚠ DANGER:** Carbon monoxide poisoning may lead to death!

**Carbon Monoxide Poisoning:** Early signs of carbon monoxide poisoning resemble the flu, with headaches, dizziness, or nausea. If you have these signs, the fireplace may not be working properly. **Get fresh air at once!** Have fireplace serviced. Some people are more affected by carbon monoxide than others. These include pregnant women, people with heart or lung disease or anemia, those under the influence of alcohol, and those at high altitudes.

**Natural and Propane/LP Gas:** Natural and propane/LP gases are odorless. An odor-making agent is added to the gas. The odor helps you detect a gas leak. However, the odor added to the gas can fade. Gas may be present even though no odor exists.

Make certain you read and understand all warnings. Keep this manual for reference. It is your guide to safe and proper operation of this fireplace.

**⚠ WARNING:** Any change to this fireplace or its controls can be dangerous.

**⚠ WARNING:** Do not allow fans to blow directly into the fireplace. Avoid any drafts that alter burner flame patterns. Ceiling fans can create drafts that alter burner flame patterns. Altered burner patterns can cause sooting.

**⚠ WARNING:** Do not use a blower insert, heat exchanger insert, or other accessory not approved for use with this fireplace.

**Due to high temperatures, the appliance should be located out of traffic and away from furniture and draperies.**

**Do not place clothing or other flammable material on or near the appliance. Never place any objects in the fireplace.**

**Fireplace front and screen becomes very hot when running fireplace. Keep children and adults away from hot surfaces to avoid burns or clothing ignition. Fireplace will remain hot for a time after shutdown. Allow surfaces to cool before touching.**

**Carefully supervise young children when they are in the room with fireplace.**

**For more information, visit [www.desatech.com](http://www.desatech.com)**

## SAFETY INFORMATION

### Continued

**You must operate this fireplace with a fireplace screen in place. Make sure fireplace screen is in place before running fireplace.**

**Keep the appliance area clear and free from combustible materials, gasoline, and other flammable vapors and liquids.**

1. This appliance is only for use with the type of gas indicated on the rating plate. This appliance is not convertible for use with other gases.
2. Do not place propane/LP supply tank(s) inside any structure. Locate propane/LP supply tank(s) outdoors (propane/LP units only).
3. If you smell gas
  - shut off gas supply
  - do not try to light any appliance
  - do not touch any electrical switch; do not use any phone in your building
  - immediately call your gas supplier from a neighbor's phone. Follow the gas supplier's instructions
  - if you cannot reach your gas supplier, call the fire department
4. This fireplace shall not be installed in a bedroom or bathroom.
5. Do not use this fireplace as a wood-burning fireplace. Use only the logs provided with the fireplace.
6. Do not add extra logs or ornaments such as pine cones, vermiculite, or rock wool. Using these added items can cause soot-fall. Do not add lava rock around base. Rock and debris could fall into the control area of fireplace.
7. This fireplace is designed to be smokeless. If logs ever appear to smoke, turn off fireplace and call a qualified service person. **Note:** During initial operation, slight smoking could occur due to log curing and fireplace burning manufacturing residues.
8. To prevent the creation of soot, follow the instructions in *Cleaning and Maintenance*, pages 17 and 18.
9. Before using furniture polish, wax, carpet cleaner, or similar products, turn heater off. If heated, the vapors from these products may create a white powder residue within burner box or on adjacent walls or furniture.
10. This fireplace needs fresh air ventilation to run properly. This fireplace has an Oxygen Depletion Sensing (ODS) safety shutoff system. The ODS shuts down the fireplace if not enough fresh air is available. See *Air for Combustion and Ventilation*, pages 4 through 6. If fireplace keeps shutting off, see *Troubleshooting*, pages 19 through 21.
11. Do not run fireplace
  - where flammable liquids or vapors are used or stored.
  - under dusty conditions.
12. Do not use this fireplace to cook food or burn paper or other objects.
13. Do not use fireplace if any part has been under water. Immediately call a qualified service technician to inspect the room fireplace and to replace any part of the control system and any gas control which has been under water.
14. Turn off and unplug fireplace and let cool before servicing. Only a qualified service person should service and repair fireplace.
15. Operating fireplace above elevations of 4,500 feet could cause pilot outage.
16. Do not operate fireplace if any log is broken. Do not operate fireplace if a log is chipped (dime-sized or larger).
17. To prevent performance problems, do not use propane/LP fuel tank of less than 100 lbs. capacity (propane/LP units only).
18. Provide adequate clearances around air openings.

## PRODUCT IDENTIFICATION

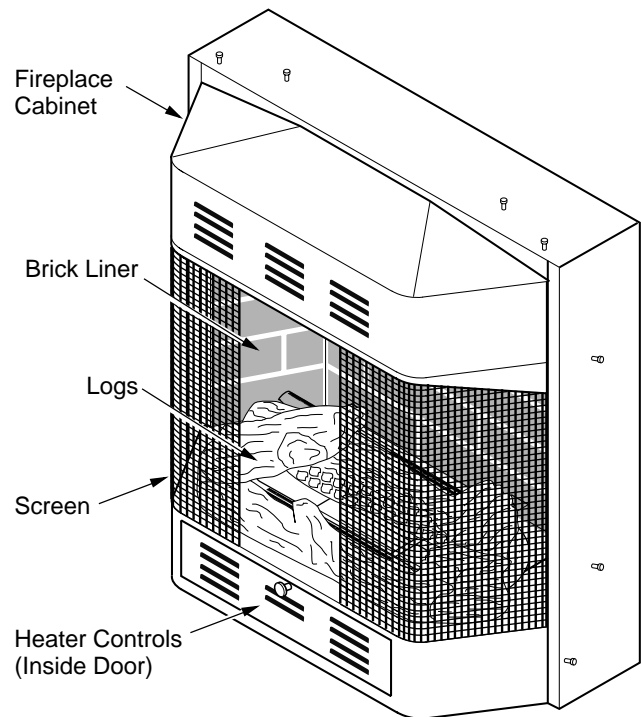

Figure 1 - Vent-Free Bay Front Compact Fireplace

## LOCAL CODES

Install and use fireplace with care. Follow all local codes. In the absence of local codes, use the latest edition of *The National Fuel Gas Code ANSI Z223.1/NFPA 54\**.

\*Available from:

American National Standards Institute, Inc.  
 1430 Broadway  
 New York, NY 10018

National Fire Protection Association, Inc.  
 Batterymarch Park  
 Quincy, MA 02269

## UNPACKING

1. Remove and fireplace from carton.
2. Remove all protective packaging applied to fireplace for shipment.
3. Make sure your fireplace includes one hardware packet.
4. Check fireplace for any shipping damage. If fireplace is damaged, promptly inform dealer where you bought fireplace.

## PRODUCT FEATURES

### SAFETY PILOT

This fireplace has a pilot with an Oxygen Depletion Sensing (ODS) safety shutoff system. The ODS/pilot is a required feature for vent-free room fireplaces. The ODS/pilot shuts off the fireplace if there is not enough fresh air.

### PIEZO IGNITION SYSTEM

This fireplace has a piezo ignitor. This system requires no matches, batteries, or other sources to light fireplace.

## AIR FOR COMBUSTION AND VENTILATION

**⚠ WARNING:** This heater shall not be installed in a confined space or unusually tight construction unless provisions are provided for adequate combustion and ventilation air. Read the following instructions to insure proper fresh air for this and other fuel-burning appliances in your home.

Today's homes are built more energy efficient than ever. New materials, increased insulation, and new construction methods help reduce heat loss in homes. Home owners weather strip and caulk around windows and doors to keep the cold air out and the warm air in. During heating months, home owners want their homes as airtight as possible.

While it is good to make your home energy efficient, your home needs to breathe. Fresh air must enter your home. All fuel-burning appliances need fresh air for proper combustion and ventilation.

Exhaust fans, fireplaces, clothes dryers, and fuel burning appliances draw air from the house to operate. You must provide adequate fresh air for these appliances. This will insure proper venting of vented fuel-burning appliances.

### PROVIDING ADEQUATE VENTILATION

The following are excerpts from *National Fuel Gas Code, ANSI Z223.1/NFPA 54, Section 5.3, Air for Combustion and Ventilation*.

All spaces in homes fall into one of the three following ventilation classifications:

1. Unusually Tight Construction
2. Unconfined Space
3. Confined Space

The information on pages 4 through 6 will help you classify your space and provide adequate ventilation.

### Unusually Tight Construction

The air that leaks around doors and windows may provide enough fresh air for combustion and ventilation. However, in buildings of unusually tight construction, you must provide additional fresh air.

**Unusually tight construction is defined as construction where:**

- a. walls and ceilings exposed to the outside atmosphere have a continuous water vapor retarder with a rating of one perm ( $6 \times 10^{-11}$  kg per pa-sec- $m^2$ ) or less with openings gasketed or sealed ***and***
- b. weather stripping has been added on openable windows and doors ***and***

# AIR FOR COMBUSTION AND VENTILATION

*Continued*

- c. caulking or sealants are applied to areas such as joints around window and door frames, between sole plates and floors, between wall-ceiling joints, between wall panels, at penetrations for plumbing, electrical, and gas lines, and at other openings.

If your home meets all of the three criteria above, you must provide additional fresh air. See *Ventilation Air From Outdoors*, page 6.

If your home does not meet all of the three criteria above, proceed to *Determining Fresh-Air Flow for Heater Location*, below.

## Confined and Unconfined Space

*National Fuel Gas Code, ANSI Z223.1/NFPA 54* defines a confined space as a space whose volume is less than 50 cubic feet per 1,000 Btu per hour (4.8 m<sup>3</sup> per kw) of the aggregate input rating of all appliances installed in that space and an unconfined space as a space whose volume is not less than 50 cubic feet per 1,000 Btu per hour (4.8 m<sup>3</sup> per kw) of the aggregate input rating of all appliances installed in that space. Rooms communicating directly with the space in which the appliances are installed\*, through openings not furnished with doors, are considered a part of the unconfined space.

\* Adjoining rooms are communicating only if there are doorless passageways or ventilation grills between them.

## DETERMINING FRESH-AIR FLOW FOR HEATER LOCATION

### Determining if You Have a Confined or Unconfined Space

Use this work sheet to determine if you have a confined or unconfined space.

**Space:** Includes the room in which you will install heater plus any adjoining rooms with doorless passageways or ventilation grills between the rooms.

- Determine the volume of the space (length x width x height).  
 Length x Width x Height = \_\_\_\_\_ cu. ft. (volume of space)  
*Example:* Space size 20 ft. (length) x 16 ft. (width) x 8 ft. (ceiling height) = 2560 cu. ft. (volume of space)  
 If additional ventilation to adjoining room is supplied with grills or openings, add the volume of these rooms to the total volume of the space.
- Multiply the space volume by 20 to determine the maximum Btu/Hr the space can support.  
 \_\_\_\_\_ (volume of space) x 20 = (Maximum Btu/Hr the space can support)  
*Example:* 2560 cu. ft. (volume of space) x 20 = 51,200 (maximum Btu/Hr the space can support)

- Add the Btu/Hr of all fuel burning appliances in the space.

Vent-free heater	_____	Btu/Hr
Gas water heater*	_____	Btu/Hr
Gas furnace	_____	Btu/Hr
Vented gas heater	_____	Btu/Hr
Gas fireplace logs	_____	Btu/Hr
Other gas appliances* +	_____	Btu/Hr
Total	= _____	Btu/Hr

\* Do not include direct-vent gas appliances. Direct-vent draws combustion air from the outdoors and vents to the outdoors.

*Example:*

Gas water heater	_____	30,000	Btu/Hr	
Vent-free heater	+	_____	26,000	Btu/Hr
Total	= _____	56,000	Btu/Hr	

- Compare the maximum Btu/Hr the space can support with the actual amount of Btu/Hr used.

_____	Btu/Hr (maximum the space can support)
_____	Btu/Hr (actual amount of Btu/Hr used)

*Example:* 51,200 Btu/Hr (maximum the space can support)  
 56,000 Btu/Hr (actual amount of Btu/Hr used)

The space in the above example is a confined space because the actual Btu/Hr used is more than the maximum Btu/Hr the space can support. You must provide additional fresh air. Your options are as follows:

- Rework worksheet, adding the space of an adjoining room. If the extra space provides an unconfined space, remove door to adjoining room or add ventilation grills between rooms. See *Ventilation Air From Inside Building*, page 6.
- Vent room directly to the outdoors. See *Ventilation Air From Outdoors*, page 6.
- Install a lower Btu/Hr heater, if lower Btu/Hr size makes room unconfined.

If the actual Btu/Hr used is less than the maximum Btu/Hr the space can support, the space is an unconfined space. You will need no additional fresh air ventilation.

**⚠ WARNING:** If the area in which the heater may be operated is smaller than that defined as an unconfined space or if the building is of unusually tight construction, provide adequate combustion and ventilation air by one of the methods described in the *National Fuel Gas Code, ANSI Z223.1/NFPA 54 Section 5.3* or applicable local codes.

## AIR FOR COMBUSTION AND VENTILATION

*Continued*

### VENTILATION AIR

#### Ventilation Air From Inside Building

This fresh air would come from an adjoining unconfined space. When ventilating to an adjoining unconfined space, you must provide two permanent openings: one within 12" of the ceiling and one within 12" of the floor on the wall connecting the two spaces (see options 1 and 2, Figure 2). You can also remove door into adjoining room (see option 3, Figure 2). Follow the *National Fuel Gas Code, ANSI Z223.1/NFPA 54, Section 5.3, Air for Combustion and Ventilation* for required size of ventilation grills or ducts.

#### Ventilation Air From Outdoors

Provide extra fresh air by using ventilation grills or ducts. You must provide two permanent openings: one within 12" of the ceiling and one within 12" of the floor. Connect these items directly to the outdoors or spaces open to the outdoors. These spaces include attics and crawl spaces. Follow the *National Fuel Gas Code, ANSI Z223.1/NFPA 54, Section 5.3, Air for Combustion and Ventilation* for required size of ventilation grills or ducts.

**IMPORTANT:** Do not provide openings for inlet or outlet air into attic if attic has a thermostat-controlled power vent. Heated air entering the attic will activate the power vent.

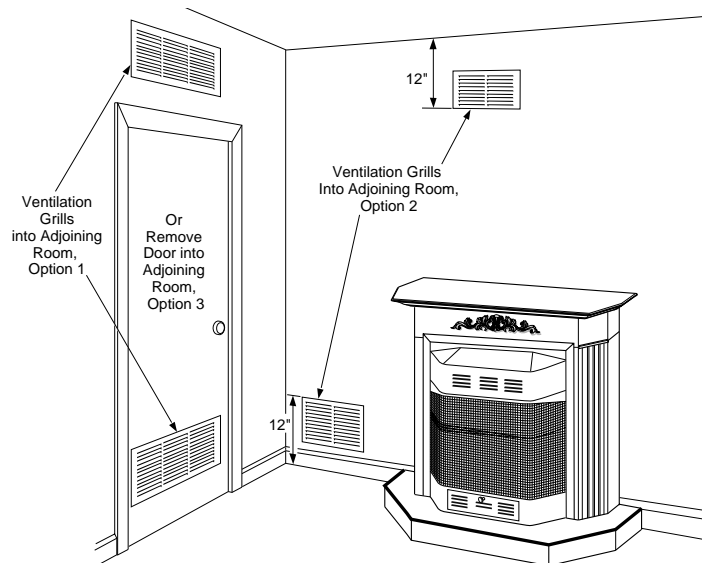

**Figure 2 - Ventilation Air from Inside Building Shown with Optional Mantel**

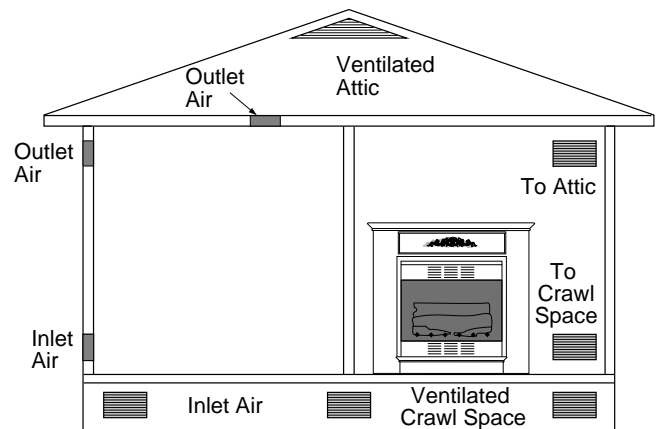

**Figure 3 - Ventilation Air from Outdoors Shown with Optional Mantel**

## INSTALLATION

**NOTICE:** This heater is intended for use as supplemental heat. Use this heater along with your primary heating system. Do not install this heater as your primary heat source. If you have a central heating system, you may run system's circulating blower while using heater. This will help circulate the heat throughout the house. In the event of a power outage, you can use this heater as your primary heat source.

**WARNING:** A qualified service person must install fireplace. Follow all local codes.

**Note:** Your Comfort Glow fireplace is designed to be used in zero clearance installations. Wall or framing material can be placed directly against any exterior surface of your fireplace, except where standoff spacers are integrally attached. If standoff spacers are attached to your fireplace, these spacers can be placed directly against wall or framing materials.

Use the dimensions shown for rough openings to create the easiest installation (see *Built-In Fireplace Installation*, page 8).

### CHECK GAS TYPE

Use the correct gas type (natural or propane/LP) for your unit. If your gas supply is not correct, do not install fireplace. Call dealer where you bought fireplace for proper type fireplace.

# INSTALLATION

## Continued

### LOCATING FIREPLACE

**⚠ WARNING:** Maintain the minimum clearances shown in Figures 4 and 5. If you can, provide greater clearances from floor, ceiling, and joining wall.

You can recess firebox into the wall. You can also position fireplace in the optional cabinet mantels. **IMPORTANT:** Only use optional cabinet mantels specified in this manual. Purchase the optional mantel from your dealer (see *Accessories*, page 29).

**⚠ WARNING:** Never install the fireplace

- in a bedroom or a bathroom
- in a recreational vehicle
- where curtains, furniture, clothing, or other flammable objects are less than 42 inches from the front, top, or sides of the fireplace
- as a fireplace insert
- in high traffic areas
- in windy or drafty areas

**⚠ CAUTION:** This fireplace creates warm air currents. These currents move heat to wall surfaces next to fireplace. Installing fireplace next to vinyl or cloth wall coverings or operating fireplace where impurities (such as, but not limited to, tobacco smoke, aromatic candles, cleaning fluids, oil or kerosene lamps, etc.) in the air exist, may discolor walls or cause odors.

**IMPORTANT:** Vent-free fireplaces add moisture to the air. Although this is beneficial, installing fireplace in rooms without enough ventilation air may cause mildew to form from too much moisture. See *Air for Combustion and Ventilation*, pages 4 through 6.

**⚠ CAUTION:** If you install the fireplace in a home garage

- fireplace pilot and burner must be at least 18 inches above floor.
- locate fireplace where moving vehicle will not hit it.

For convenience and efficiency, install fireplace

- where there is easy access for operation, inspection, and service.
- in coldest part of room.

An optional blower kit is available from your dealer. See *Accessories*, page 29. If planning to use blower, locate fireplace near an electrical outlet.

*Note:* When installing fireplace directly on carpeting, tile or other combustible material, other than wood flooring, the fireplace shall be installed on a metal or wood panel extending the full width and depth of the fireplace.

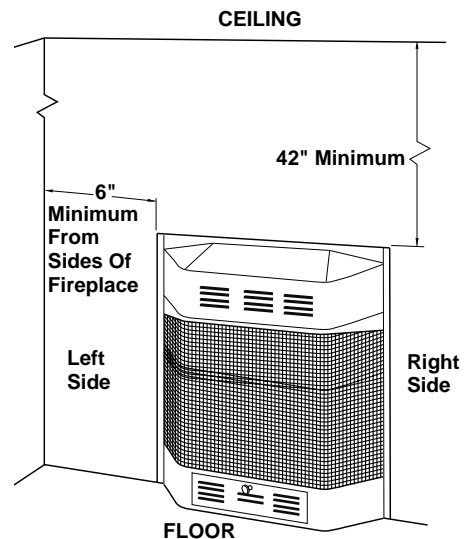

0" Minimum Clearance To Top Surface Of Carpeting, Tile Or Other Combustible Material

**Figure 4 - Mounting Clearances As Viewed From Front of Fireplace Shown Built In The Wall**

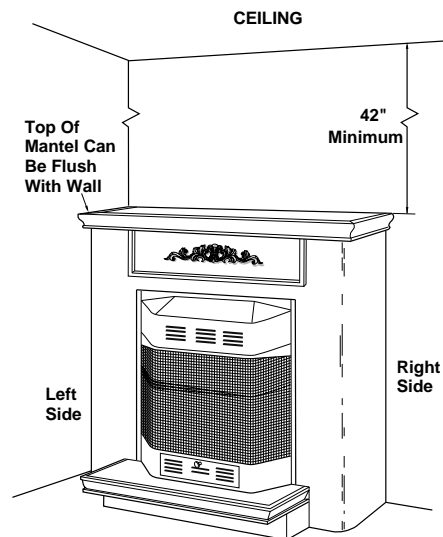

0" Minimum Clearance To Top Surface Of Carpeting, Tile Or Other Combustible Material

**Figure 5 - Mounting Clearances As Viewed From Front of Fireplace Shown with Optional Mantel**

## INSTALLATION

### Continued

#### BUILT-IN FIREPLACE INSTALLATION

Built-in installation of this fireplace involves installing fireplace into a framed-in enclosure. This makes the front of fireplace flush with wall. Follow the instructions below to install the fireplace in this manner. If installing a built-in mantel above the fireplace, you must follow the clearances shown in Figure 9, page 9. If using for built-in installation off of the floor, follow clearances shown in Figure 4, page 7.

	Height	Front Width	Depth	Bottom
Actual	26"	26 <sup>3</sup> / <sub>4</sub> "	9 <sup>1</sup> / <sub>2</sub> "	3/4"
Framing	26 <sup>7</sup> / <sub>8</sub> "	26 <sup>7</sup> / <sub>8</sub> "	10 <sup>1</sup> / <sub>2</sub> "	3/4"

1. Frame in rough opening. Use dimensions shown in Figure 6 for the rough opening.

If installing in a corner, use dimensions shown in Figure 7 for the rough opening. The height is 26 <sup>1</sup>/<sub>8</sub>" which is the same as the wall opening above.

2. An optional blower accessory is available (see *Accessories*, page 29). There are two options for connecting blower to electrical source.

**Option one:** Have a licensed electrician install a properly grounded, three-prong 120-volt electrical outlet at fireplace location. Locate outlet inside the framed enclosure. Blower power cord will plug into this outlet.

**Option two:** Have a licensed electrician connect blower to electrical source at junction box inside fireplace.

If using option one, have electrical outlet installed at this time. If using option two, do not connect blower to electrical source at junction box until step 6.

3. Install gas piping to fireplace location. This installation includes an approved flexible gas line (if allowed by local codes) after the equipment shutoff valve. The flexible gas line must be the last item installed on the gas piping.
4. Carefully set fireplace in front of rough opening with back of fireplace inside wall opening.
5. Attach flexible gas line to fireplace gas regulator. See *Connecting Fireplace to Gas Supply*, pages 13 and 14.
6. If the optional blower has been installed connect blower to electrical source.

**Option one:** Route blower electrical cord through side or rear access door of fireplace. Plug electrical cord into electrical outlet.

**Option two:** Have a licensed electrician connect blower to electrical source at junction box inside fireplace.

7. Bend four nailing flanges on outer casing with pliers (see Figure 8, page 9).

8. Attach fireplace to wall studs using nails or wood screws through holes in nailing flange.
9. Check all gas connections for leaks. See *Checking Gas Connections*, pages 14 and 15.

**IMPORTANT:** When finishing your firebox, combustible materials such as wall board, gypsum board, sheet rock, drywall, plywood, etc. may be butted up next to the sides and top of the firebox. Combustible materials should never overlap the firebox front facing. Firebox should not be placed on top of carpet or other kinds of fibrous material.

**WARNING:** Do not allow any combustible materials to overlap the firebox front facing.

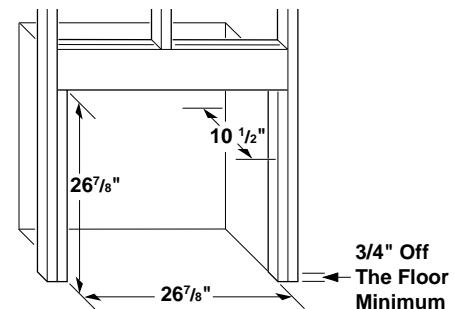

Figure 6 - Rough Opening for Installing in Wall

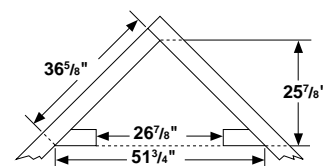

Figure 7 - Rough Opening for Installing in Corner

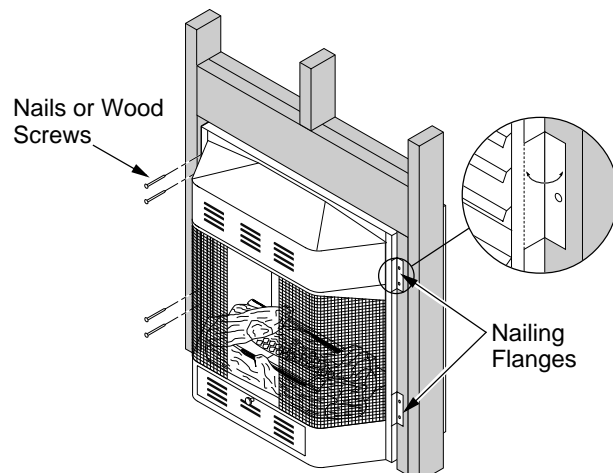

Figure 8 - Attaching Fireplace to Wall Studs

For more information, visit [www.desatech.com](http://www.desatech.com)



## INSTALLATION

### Continued

**IMPORTANT:** Noncombustible materials such as brick, tile, etc. may overlap the front facing, but should never cover any necessary openings like louvered slots.

**⚠ WARNING:** Do not allow noncombustible materials to cover any necessary openings like louvered slots.

**⚠ WARNING:** Never modify or cover the louvered slots on the front of the firebox.

**⚠ WARNING:** Use only noncombustible mortar or adhesives when overlapping the front facing with noncombustible facing material.

### Mantel Clearances for Built-In Installation

If placing mantel above built-in fireplace, you must meet minimum clearance between mantel shelf and top of fireplace opening.

**NOTICE:** Surface temperatures of adjacent walls and mantels become hot during operation. Walls and mantels above the firebox may become hot to the touch. If installed properly, these temperatures meet the requirement of the national product standard. Follow all minimum clearances shown in this manual.

**NOTICE:** If your installation does not meet the minimum clearances shown, you must do one of the following:

- raise the mantel to an acceptable height
- remove the mantel

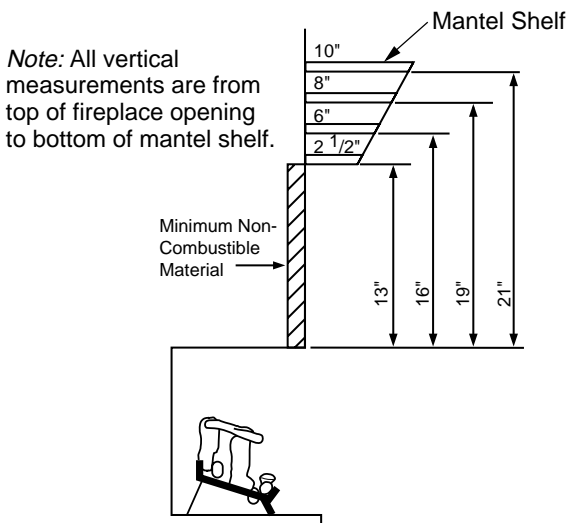

**Figure 9 - Minimum Mantel Clearances for Built-In Installation**

### REMOVING BRICK LINER RETAINER

1. Using Phillips screw driver, remove 2 screws attaching brick liner retainers to vertical sides.
2. Remove brick liner retainers and discard. Replace 2 screws into vertical sides.

### ASSEMBLING TRIM (Trim shipped with mantel)

1. Remove packaging from three pieces of trim.
2. Locate two adjusting plates with set screws, and two shims in the hardware packet.
3. Align shim under adjusting plate as shown in Figure 10.
4. Slide one end of adjusting plate/shim in slot on mitered edge of top trim (see Figure 10).
5. Slide other end of adjusting plate/shim in slot on mitered edge of side trim (see Figure 10).
6. While firmly holding edges of trim together, tighten both set screws on the adjusting plate with slotted screwdriver.
7. Repeat steps 1 through 6 for other corner.
8. Set brass assembly aside for later installation.

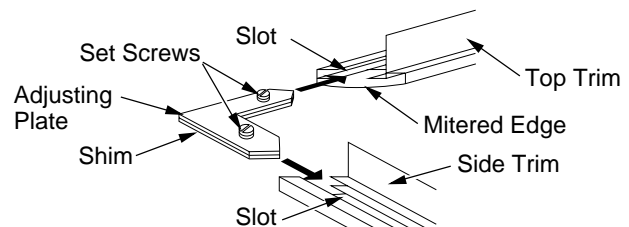

**Figure 10 - Assembling Trim**

### OPTIONAL MANTEL INSTALLATION

**Note:** Refer to instructions provided with the mantel for assembly instructions. Refer to instructions below for system installation. If using blower accessory (see *Accessories*, page 29), see installation instructions on pages 11 and 12.

1. Choose location for fireplace and install gas supply line.
2. Remove screen from fireplace by removing screws in each end of screen rod (see Figure 11, page 10). Hold screen rod cover while removing five hex head screws underneath hood (see Figure 12, page 10). Carefully lift and pull out hood (see Figure 13, page 10).
3. Assemble trim kit. See *Assembling Trim*, above.
4. Place trim on the shoulder screws located on the side and top of the fireplace. Firmly snap the trim over the shoulder screws on fireplace (see Figure 14, page 10).
5. Place mantel base close to wall in desired fireplace location.
6. Install gas line. See *Connecting To Gas Supply*, pages 12 and 13.

## INSTALLATION

### Continued

7. Carefully place fireplace on mantel base and center left to right. Check for gas leaks. See *Checking Gas Connections*, pages 14 and 15.
8. Refer to instructions provided with the mantel for permanent attachment to wall.
9. Slide mantel around fireplace. Be careful not to damage wall or mantel.
10. Adjust assembly to remove any gaps. From back side of fireplace, attach two 2" wood screws through base mounting blocks attached to bottom sides of mantel into base (see instructions provided with mantel).
11. Attach remaining two 3" wood screws from hardware pack through openings inside of fireplace sides into the mantel. See Figure 13 for screw hole location.

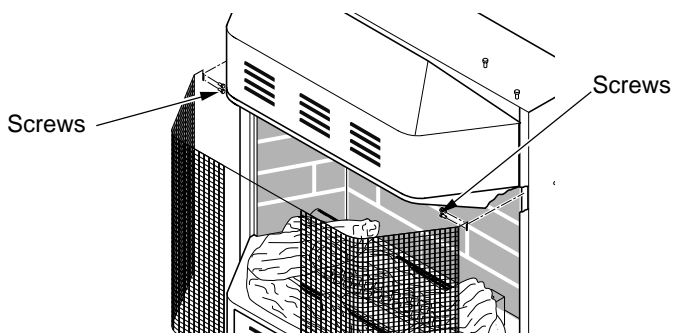

Figure 11 - Removing Screen

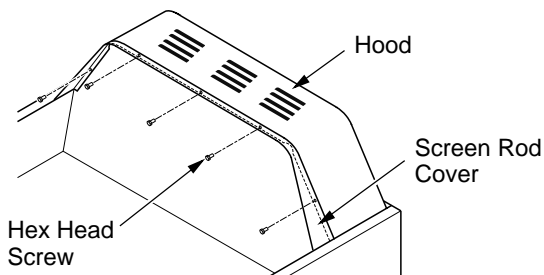

Figure 12 - Removing Hood Screws

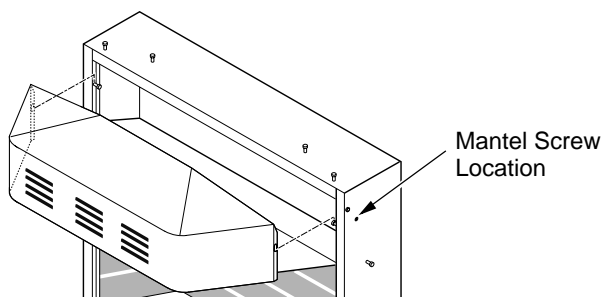

Figure 13 - Removing Hood

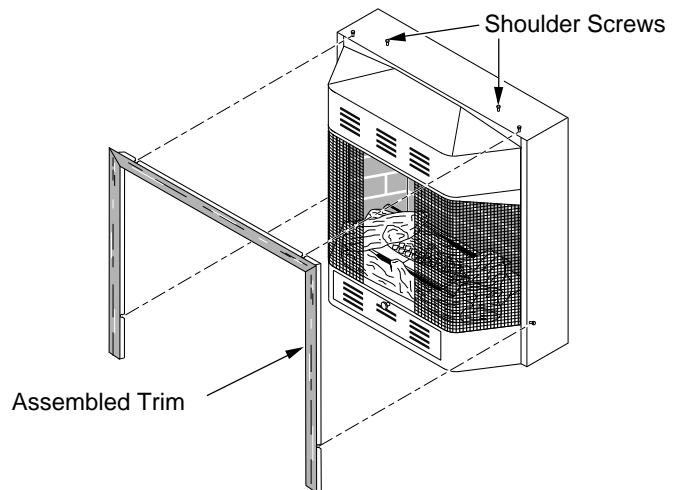

Figure 14 - Attaching Trim to Fireplace

## INSTALLING BLOWER ASSEMBLY - GA3450T

**CAUTION:** Label all wires prior to disconnection when servicing controls. Wiring errors can cause improper and dangerous operation.

**CAUTION:** Verify proper operation after servicing.

**Note:** If you are using a mantel with your heater, use the following instructions. If your heater is built-in, see *For Built-In Installation* on page 12.

1. Screen and hood should be removed from fireplace (see page 10). Remove log set and set aside.
2. Install snap bushings found in hardware kit into both holes in rear of blower control shield (see Figure 15).
3. Make sure the wire harness is firmly connected to the terminals on the blower bracket assembly.

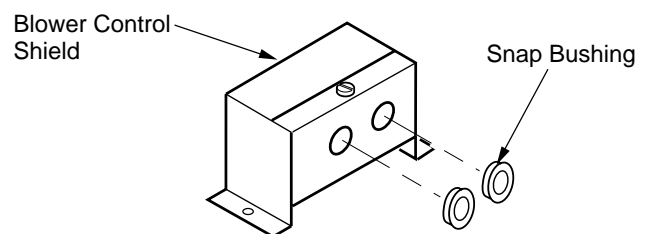
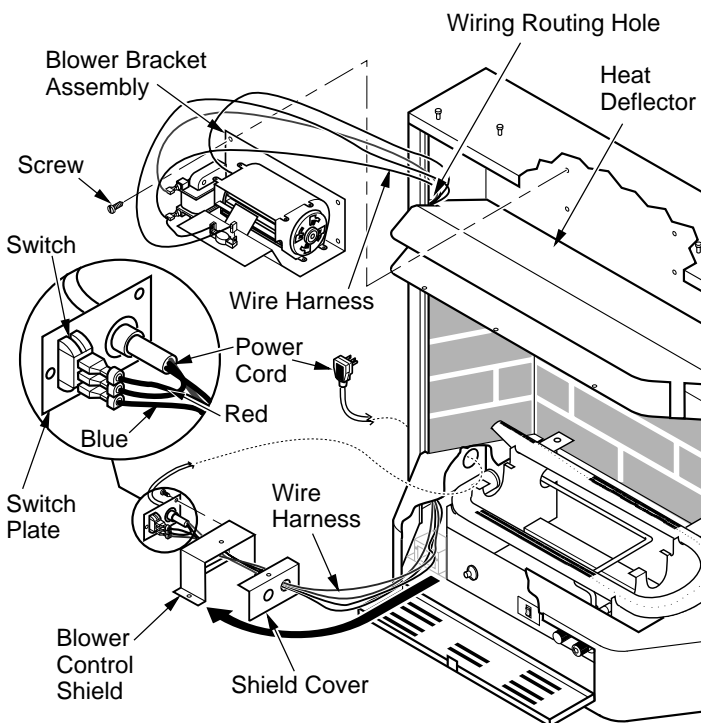

Figure 15 - Installing Snap Bushings

# INSTALLATION

## Continued

4. Note the wire locations on back of AUTO/OFF/ON switch. Carefully remove red wire from the AUTO terminal and blue wire from the ON terminal. Black wire can remain on the middle or OFF terminal (see Figure 16).
5. Carefully disconnect green and white wires from power cord harness at their insulated connectors.
6. In top of the heater cabinet, locate the four mounting holes on the outer casing. Align these four holes with those on the blower bracket assembly. Attach blower bracket assembly to the outer casing with 4 - #10 screws provided (see Figure 16).
7. Route the wire harness through the hole to the left side of heat deflector. Pull wire harness through lower opening to the left of the blower control shield. (see Figure 16).
8. Insert the 4 wire harness into one of the round holes in the rear of the blower control shield and through the rectangular hole in the front of shield (see Figure 16).
9. Reconnect red wire to the AUTO switch position. Reconnect blue wire to the ON switch position. Reconnect green and white wires to the power cord.



**Figure 16 - Installing Blower Bracket Assembly**

10. Install the switch plate on the blower control shield with 2 - #10 screws provided (see Figure 17). Route power cord out of the cabinet by inserting it through the bushing on the outer casing (see Figure 16). Plug fan kit into 120-Volt grounded power supply and test operation. *Note:* When switch is in the AUTO position, the fan will start after the heater has run for a few moments. The fan will continue to run for several moments after the heater has been turned off. When switch is in the ON position, the fan will run until turned to OFF. Reinstall hood assembly and close lower louver door.
11. Place log set back on the unit.

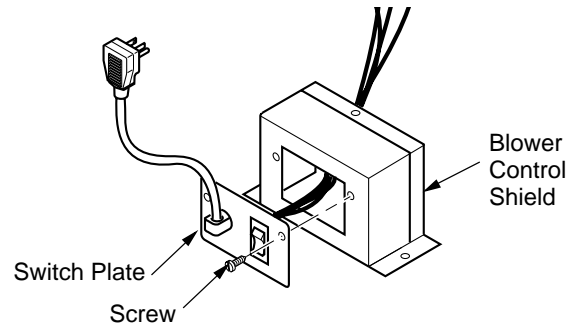

**Figure 17 - Installing Switch Plate to Blower Control Shield**

### For Built-In Installation

**⚠ WARNING:** A licensed electrician must connect the wiring harness to electrical supply following all local codes. Electrician must provide a clamp on the box cover to secure the wiring. Wiring should be routed through the bushing in the hole on the outer casing of heater.

1. Install a snap bushing found in hardware kit into one of the holes found on rear of blower control shield. The other hole is for a strain relief clamp (not supplied) to secure incoming electrical supply.
2. Follow steps 2 through 6 in *Installing Blower Assembly* beginning on page 10. Also remove black wire from middle/OFF switch terminal.
3. Remove black plastic strain relief and power cord from switch plate (see Figure 18, page 12). The power cord supplied will not be used in built-in installations. Pop in the plastic snap bushing found in hardware kit into the hole left by supply cord/strain relief.
4. A licensed electrician must follow the wiring diagram in Figure 19, page 12 to connect incoming electrical supply to fan kit wiring harness.

## INSTALLATION

### Continued

5. Test to make sure the blower is working properly.
6. Reinstall hood assembly (see pages 9 and 10) and close lower louver door.
7. Place log set back on the unit.

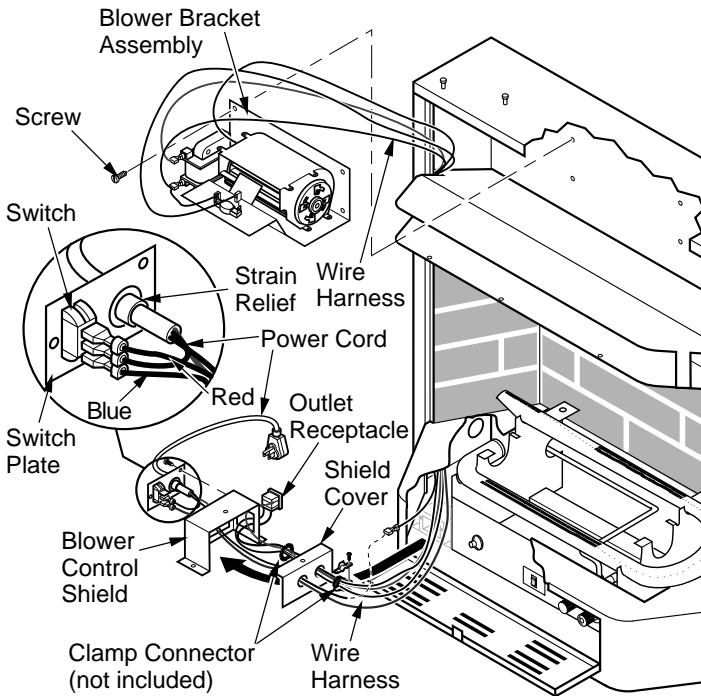

Figure 18 - Installing Blower Bracket Assembly

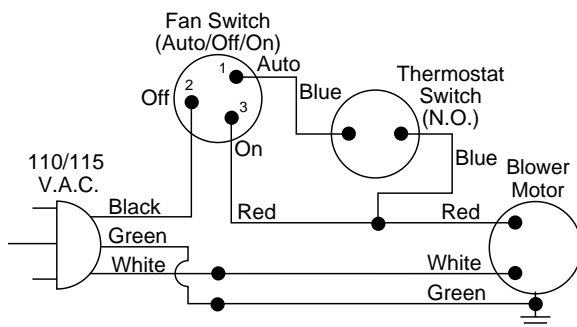

Figure 19 - Wiring Diagram For Fan Accessory Built-In Installation

### CONNECTING TO GAS SUPPLY

**⚠ WARNING:** This appliance requires a 1/2" NPT (National Pipe Thread) inlet connection to the pressure regulator.

**⚠ WARNING:** A qualified service person must connect fireplace to gas supply. Follow all local codes.

**⚠ CAUTION:** Never connect propane/LP fireplace directly to the propane/LP supply. This fireplace requires an external regulator (not supplied). Install the external regulator between the fireplace and propane/LP supply.

**⚠ WARNING:** Never connect natural gas fireplace to private (non-utility) gas wells. This gas is commonly known as wellhead gas.

### Installation Items

Before installing fireplace, make sure you have the items listed below.

- external regulator - propane/LP only (supplied by installer)
- piping (check local codes)
- sealant (resistant to propane/LP gas)
- equipment shutoff valve \*
- ground joint union
- sediment trap
- tee joint
- pipe wrench
- test gauge connection\*

\* A CSA design-certified equipment shutoff valve with 1/8" NPT tap is an acceptable alternative to test gauge connection. Purchase the optional CSA design-certified equipment shutoff valve from your dealer. See *Accessories*, page 29.

**Note:** If desired, purchase a four-sided trim kit for built-in installations. See *Accessories*, page 29.

For propane/LP units, the installer must supply an external regulator. The external regulator will reduce incoming gas pressure. You must reduce incoming gas pressure to between 11 and 14 inches of water. If you do not reduce incoming gas pressure, fireplace regulator damage could occur. Install external regulator with the vent pointing down as shown in Figure 20, page 13. Pointing the vent down protects it from freezing rain or sleet.

# INSTALLATION

*Continued*

**⚠ CAUTION:** Use only new, black iron or steel pipe. Internally-tinned copper tubing may be used in certain areas. Check your local codes. Use pipe of 1/2" or greater diameter to allow proper gas volume to fireplace. If pipe is too small, undue loss of volume will occur.

Installation must include a equipment shutoff valve, union, and plugged 1/8" NPT tap. Locate NPT tap within reach for test gauge hook up. NPT tap must be upstream from fireplace (see Figure 21).

**IMPORTANT:** Install equipment shutoff valve in an accessible location. The equipment shutoff valve is for turning on or shutting off the gas to the appliance.

Check your building codes for special requirements for locating equipment shutoff valve to fireplaces.

Apply pipe joint sealant lightly to male NPT threads. This will prevent excess sealant from going into pipe. Excess sealant in pipe could result in clogged fireplace valves.

**⚠ WARNING:** Use pipe joint sealant that is resistant to liquid petroleum (LP) gas.

We recommend that you install a sediment trap in supply line as shown in Figure 21. Locate sediment trap where it is within reach for cleaning. Install in piping system between fuel supply and heater. Locate sediment trap where trapped matter is not likely to freeze. A sediment trap traps moisture and contaminants. This keeps them from going into fireplace controls. If sediment trap is not installed or is installed wrong, fireplace may not run properly.

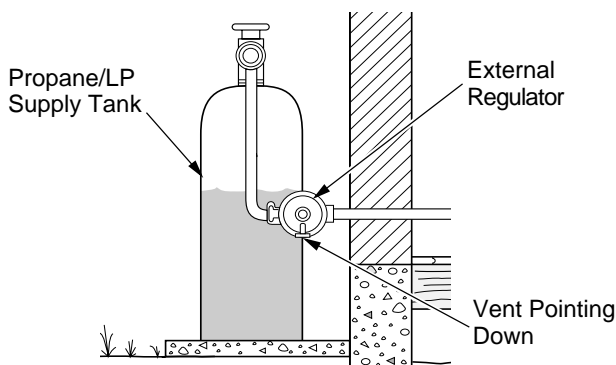

**Figure 20 - External Regulator with Vent Pointing Down**

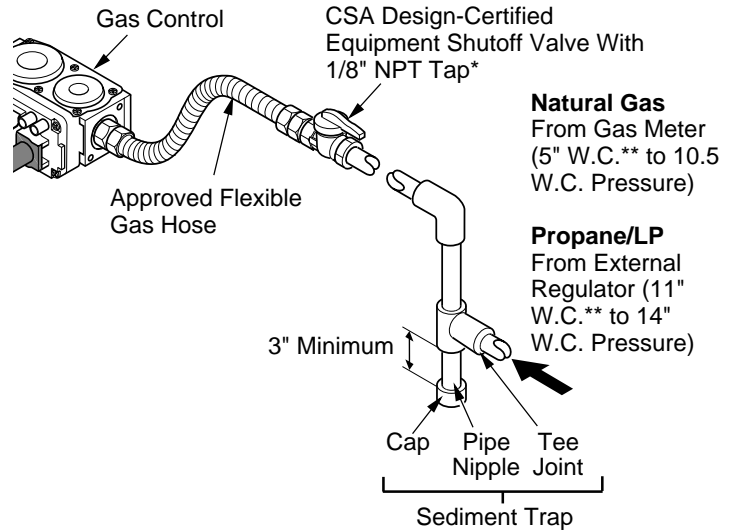

**Figure 21 - Gas Connection**

\* Purchase the optional CSA design-certified equipment shutoff valve from your dealer. See *Accessories*, page 29.

\*\* Minimum inlet pressure for purpose of input adjustment.

## CONNECTING FIREPLACE TO GAS SUPPLY

### Installation Items Needed

- Phillips screwdriver
  - sealant (resistant to propane/LP gas, not provided)
1. Route flexible gas line (provided by installer) from equipment shutoff valve into fireplace through side or rear access holes in outer casing (see Figure 22).

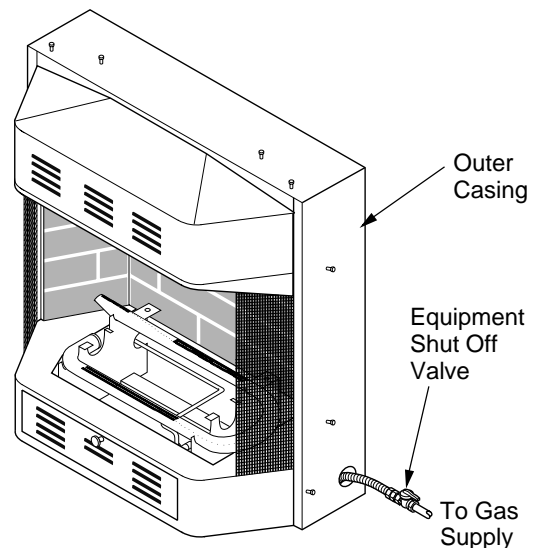

**Figure 22 - Routing Flexible Gas Line**

## INSTALLATION

### Continued

**NOTICE:** Most building codes do not permit concealed gas connections. A flexible gas line is provided to allow accessibility from the fireplace (see Figure 23). The flexible gas supply line connection to the equipment shutoff valve should be accessible.

2. Apply pipe joint sealant lightly to male threads of gas connector attached to flexible gas line (see Figure 23).
3. Check all gas connections for leaks. See *Checking Gas Connections*.
4. Feed flexible gas line into fireplace base area. Make sure the entire flexible gas line is in fireplace mantel base area.

**CAUTION:** Avoid damage to regulator. Hold gas regulator with wrench when connecting it to gas piping and/or fittings.

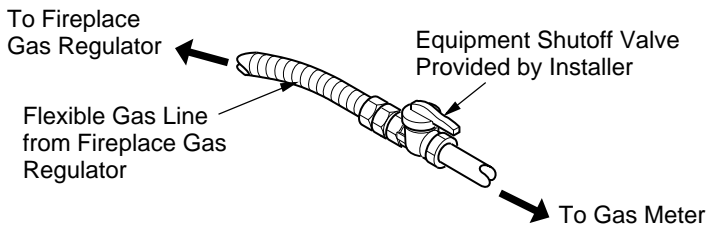

Figure 23 - Attaching Flexible Gas Lines Together

## CHECKING GAS CONNECTIONS

**WARNING:** Test all gas piping and connections, internal and external to unit, for leaks after installing or servicing. Correct all leaks at once.

**WARNING:** Never use an open flame to check for a leak. Apply a noncorrosive leak detection fluid to all joints. Bubbles forming show a leak. Correct all leaks at once.

**CAUTION:** Make sure external regulator has been installed between propane/LP supply and fireplace. See guidelines under *Connecting to Gas Supply*, pages 12 and 13.

### Pressure Testing Gas Supply Piping System

#### Test Pressures In Excess Of 1/2 PSIG (3.5 kPa)

1. Disconnect appliance with its appliance main gas valve (control valve) and equipment shutoff valve from gas supply piping system. Pressures in excess of 1/2 psig will damage fireplace regulator.

2. Cap off open end of gas pipe where equipment shutoff valve was connected.
3. Pressurize supply piping system by either opening propane/LP supply tank valve for propane/LP gas or opening main gas valve located on or near gas meter for natural gas, or using compressed air.
4. Check all joints of gas supply piping system. Apply noncorrosive leak detection fluid to gas joints. Bubbles forming show a leak.
5. Correct all leaks at once.
6. Reconnect heater and equipment shutoff valve to gas supply. Check reconnected fittings for leaks.

#### Test Pressures Equal To or Less Than 1/2 PSIG (3.5 kPa)

1. Close equipment shutoff valve (see Figure 24).
2. Pressurize supply piping system by either opening propane/LP supply tank valve for propane/LP gas or opening main gas valve located on or near gas meter for natural gas, or using compressed air.
3. Check all joints from gas meter for natural gas (see Figure 25) or propane/LP supply tank to equipment shutoff valve for propane/LP gas (see Figure 26, page 15). Apply noncorrosive leak detection fluid to gas joints. Bubbles forming show a leak.
4. Correct all leaks at once.

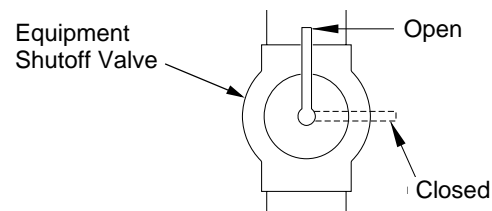

Figure 24 - Equipment Shutoff Valve

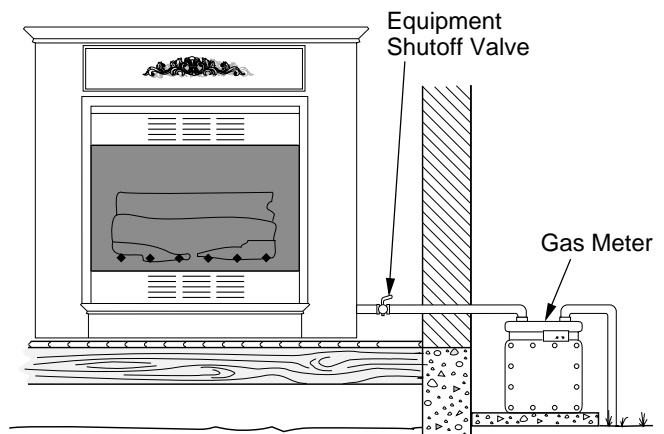
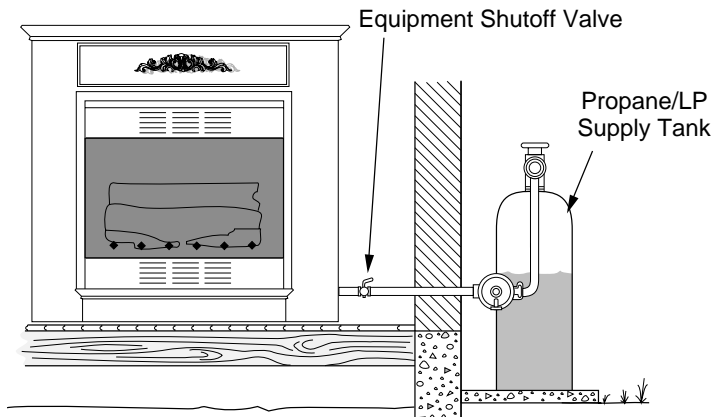

Figure 25 - Checking Gas Joints for Natural Gas Unit (Shown With Optional Mantel)

## INSTALLATION

### Continued



**Figure 26 - Checking Gas Joints for Propane/LP Units (Shown with Optional Mantel)**

### Pressure Testing Fireplace Gas Connections

1. Open equipment shutoff valve (see Figure 24, page 14).
2. Open main gas valve located on or near gas meter for natural gas or open propane/LP supply tank valve.
3. Make sure control knob of fireplace is in the OFF position.
4. Check all joints from equipment shutoff valve to thermostat gas valve (see Figure 23, page 14). Apply noncorrosive leak detection fluid to gas joints. Bubbles forming show a leak.
5. Correct all leaks at once.
6. Light fireplace (see *Operating Fireplace*, pages 16 and 17). Check all other internal joints for leaks.
7. Turn off fireplace (see *To Turn Off Gas to Appliance*, page 16).
8. Replace front panel.

## INSTALLING LOGS

**⚠ WARNING:** Failure to position the parts in accordance with these diagrams or failure to use only parts specifically approved with this heater may result in property damage or personal injury.

**⚠ CAUTION:** After installation and periodically thereafter, check to ensure that no flame comes in contact with any log. With the heater set to HI, check to see if flames contact any log. If so, reposition logs according to the log installation instructions in this manual. Flames contacting logs will create soot.

It is very important to install the logs exactly as instructed. Do not modify logs. Only use logs supplied with heater.

Place one-piece log set on grate to fit as illustrated in Figure 27. Make sure back section of log set is seated into “U”-shaped cutout in center of chassis (see Figure 27). **IMPORTANT:** Make sure log does not cover any burner ports (see Figure 28).

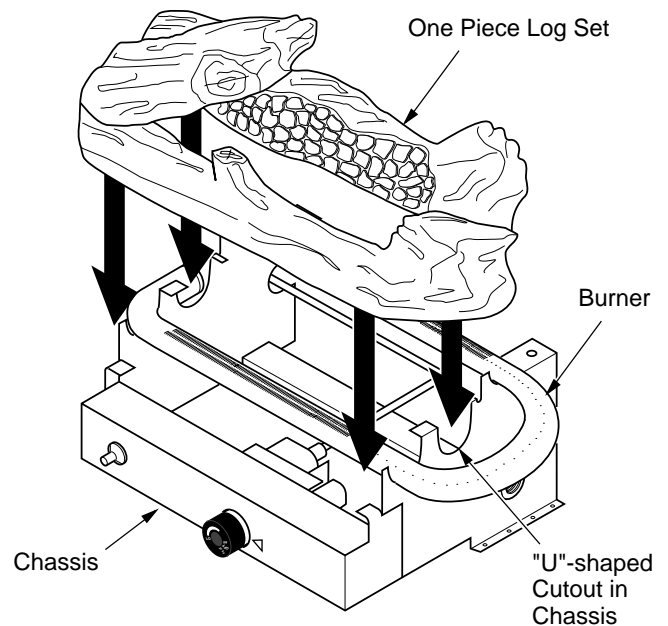

**Figure 27 - Installing One-Piece Log Set**

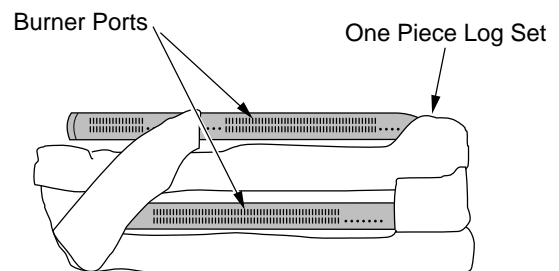

**Figure 28 - Installing One-Piece Log set (Top View)**

## OPERATING FIREPLACE



### FOR YOUR SAFETY READ BEFORE LIGHTING

**⚠ WARNING:** If you do not follow these instructions exactly, a fire or explosion may result causing property damage, personal injury or loss of life.

- This appliance has a pilot which must be lighted by hand. When lighting the pilot, follow these instructions exactly.
- BEFORE LIGHTING** smell all around the appliance area for gas. Be sure to smell next to the floor because some gas is heavier than air and will settle on the floor.  
**WHAT TO DO IF YOU SMELL GAS**
  - Do not try to light any appliance.
  - Do not touch any electric switch; do not use any phone in your building.
  - Immediately call your gas supplier from a neighbor's phone. Follow the gas supplier's instructions.
  - If you cannot reach your gas supplier, call the fire department.
- Use only your hand to push in or turn the gas control knob. Never use tools. If the knob will not push in or turn by hand, don't try to repair it, call a qualified service technician or gas supplier. Force or attempted repair may result in a fire or explosion.
- Do not use this appliance if any part has been under water. Immediately call a qualified service technician to inspect the appliance and to replace any part of the control system and any gas control which has been under water.

### LIGHTING INSTRUCTIONS

**NOTICE:** During initial operation of new heater, burning logs will give off a paper-burning smell. Orange flame will also be present. Open damper or window to vent smell. This will only last a few hours.

- STOP!** Read the safety information above.
- Make sure equipment shutoff valve is fully open.
- Turn control knob clockwise  to the OFF position.
- Wait five (5) minutes to clear out any gas. Then smell for gas, including near the floor. If you smell gas, **STOP!** Follow "B" in the safety information above. If you don't smell gas, go to the next step.
- Turn control knob counterclockwise  to the PILOT position. Press in control knob for five (5) seconds (see Figure 29).

**Note:** You may be running this heater for the first time after hooking up to gas supply. If so, the control knob may need to be pressed in for 30 seconds or more. This will allow air to bleed from the gas system.

- If control knob does not pop out when released, contact a qualified service person or gas supplier for repairs.
- With control knob pressed in, press and release ignitor button. This will light pilot. The pilot is attached to the front burner. If needed, keep pressing ignitor button until pilot lights.  
**Note:** If pilot does not stay lit, contact a qualified service person or gas supplier for repairs. Until repairs are made, light pilot with match. To light pilot with match, see *Manual Lighting Procedure*, page 17.
  - Keep control knob pressed in for 30 seconds after lighting pilot. After 30 seconds, release control knob.  
**Note:** If pilot goes out, repeat steps 3 through 7. This heater has a safety interlock system. Wait one (1) minute for system to reset before lighting pilot again.
  - Turn control knob counterclockwise  to desired heating level. The burners should light. Set control knob to any heat level between HI and LO.

**⚠ CAUTION:** Do not try to adjust heating levels by using the equipment shutoff valve.

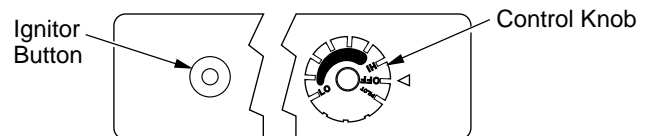

Figure 29 - Control Knob and Ignitor Button

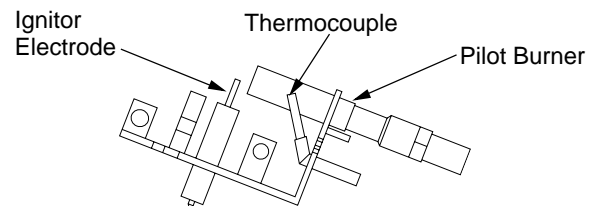



Figure 30 - Pilot (Propane/LP Shown)

### TO TURN OFF GAS TO APPLIANCE

#### Shutting Off Heater

Turn control knob clockwise  to the OFF position.

#### Shutting Off Burners Only (pilot stays lit)

Turn control knob clockwise  to the PILOT position.



## OPERATING FIREPLACE

*Continued*

### THERMOSTAT CONTROL OPERATION

The thermostat control knob can be set to any comfort level between HI and LO. The thermostat will gradually modulate the heat output and flame height from higher to lower settings, or pilot, in order to maintain the comfort level you select. The ideal comfort setting will vary by household depending upon the amount of space to be heated, the output of the central heating system, etc.

**Note:** Selecting the HI setting with the control knob will cause the burner to remain fully on, without modulating down in most cases.

### MANUAL LIGHTING PROCEDURE

1. Follow steps 1 through 5 under *Lighting Instructions*, page 16.
2. Depress control knob and light pilot with match.
3. Keep control knob pressed in for 30 seconds after lighting pilot. After 30 seconds, release control knob. Now follow step 8 under *Lighting Instructions*, page 16.

## INSPECTING BURNERS

Check pilot flame pattern and burner flame patterns often.

### PILOT FLAME PATTERN

Figure 31 shows a correct pilot flame pattern. Figure 32 shows an incorrect pilot flame pattern. The incorrect pilot flame is not properly heating the thermocouple. This will cause the thermocouple to cool. When the thermocouple cools, the heater will shut down.

If pilot flame pattern is incorrect, as shown in Figure 32

- turn heater off (see *To Turn Off Gas to Appliance*, page 16)
- see *Troubleshooting*, pages 19 through 21

**Note:** The pilot flame on natural gas units will have a slight curve, but flame should be blue and have no orange color.

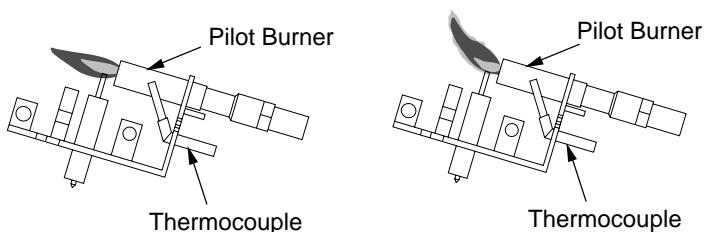

**Figure 31 - Correct Pilot Flame Pattern (Propane/LP Shown)**

**Figure 32 - Incorrect Pilot Flame Pattern (Propane/LP Shown)**

### BURNER PRIMARY AIR HOLES

Air is drawn into the burner through the holes in the fitting at the burner entrance. These holes may become blocked with dust or lint. Periodically inspect these holes for any blockage and clean if needed. Blocked air holes will create soot.

### MAIN BURNER

Periodically inspect all burner flame holes with the heater running. All slotted burner flame holes should be open with yellow flame present. All round burner flame holes should be open with a small blue flame present. Some burner flame holes may become blocked by debris or rust, with no flame present. If so, turn off heater and let cool. Remove blockage. Blocked burner flame holes will create soot.

## CLEANING AND MAINTENANCE

**WARNING:** Turn off heater and let cool before cleaning.

**CAUTION:** You must keep control areas, burners, and circulating air passageways of heater clean. Inspect these areas of heater before each use. Have heater inspected yearly by a qualified service person. Heater may need more frequent cleaning due to excessive lint from carpeting, bedding material, pet hair, etc.

**WARNING:** Failure to keep the primary air opening(s) of the burner(s) clean may result in sooting and property damage.

### CLEANING BURNER INJECTOR HOLDER AND PILOT AIR INLET HOLE

The primary air inlet holes allow the proper amount of air to mix with the gas. This provides a clean burning flame. Keep these holes clear of dust, dirt, lint, and pet hair. Clean these air inlet holes prior to each heating season. Blocked air holes will create soot. We recommend that you clean the unit every three months during operation and have heater inspected yearly by a qualified service person.

We also recommend that you keep the burner tube and pilot assembly clean and free of dust and dirt. To clean these parts we recommend using compressed air no greater than 30 PSI. Your local computer store, hardware store, or home center may carry compressed air in a can. You can use a vacuum cleaner in the blow position. If using compressed air in a can, please follow the directions on the can. If you don't follow directions on the can, you could damage the pilot assembly.

## CLEANING AND MAINTENANCE

### continued

1. Shut off the unit, including the pilot. Allow the unit to cool for at least thirty minutes.
2. Inspect burners, pilot, and primary air inlet holes on injector holder for dust and dirt (see Figure 33).
3. Blow air through the ports/slots and holes in the burners.
4. Check the injector holder located at the end of the burner tube again. Remove any large particles of dust, dirt, lint, or pet hair with a soft cloth or vacuum cleaner nozzle.
5. Blow air into the primary air holes on the injector holder.
6. In case any large clumps of dust have now been pushed into the burner repeat steps 3 and 4.

Clean the pilot assembly also. A yellow tip on the pilot flame indicates dust and dirt in the pilot assembly. There is a small pilot air inlet hole about two inches from where the pilot flame comes out of the pilot assembly (see Figure 34). With the unit off, lightly blow air through the air inlet hole. You may blow through a drinking straw if compressed air is not available.

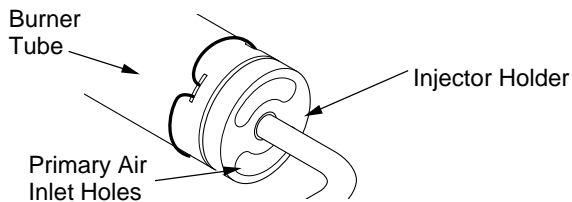

Figure 33 - Injector Holder On Outlet Burner Tube

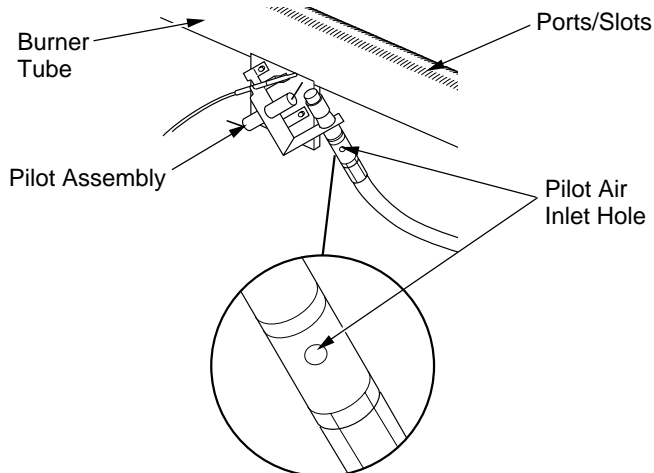

Figure 34 - Pilot Inlet Air Hole

## CABINET

### Air Passageways

- Use a vacuum cleaner or pressurized air to clean.

### Exterior

- Use a soft cloth dampened with a mild soap and water mixture. Wipe the cabinet to remove dust.

## SPECIFICATIONS

	CF26PT	CF26NT
Btu (Variable)	19,000/26,000	19,000/26,000
Type Gas	Propane/LP Only	Natural Only
Ignition	Piezo	Piezo
Manifold Pressure	8" W.C.	3.5" W.C.
Inlet Gas Pressure (in. of water) *		
Maximum	14"	10.5"
Minimum	11"	5"
Dimensions, Inches (H x W x D)		
Fireplace	25 <sup>7</sup> / <sub>8</sub> x 27 x 13 <sup>3</sup> / <sub>4</sub>	25 <sup>7</sup> / <sub>8</sub> x 27 x 13 <sup>3</sup> / <sub>4</sub>
Carton	28 x 26 <sup>13</sup> / <sub>16</sub> x 16 <sup>1</sup> / <sub>2</sub>	28 x 26 <sup>13</sup> / <sub>16</sub> x 16 <sup>1</sup> / <sub>2</sub>
Weight, pounds		
Fireplace	44 <sup>1</sup> / <sub>2</sub> lbs.	44 <sup>1</sup> / <sub>2</sub> lbs.
Shipping	55 lbs.	55 lbs.

\* For purposes of input adjustment

## SERVICE HINTS

### When Gas Pressure Is Too Low

- pilot will not stay lit
- burners will have delayed ignition
- heater will not produce specified heat
- propane/LP gas supply may be low (propane/LP only)

You may feel your gas pressure is too low. If so, contact your local natural or propane/LP gas supplier.

## TECHNICAL SERVICE

You may have further questions about installation, operation, or troubleshooting. If so, contact DESA Heating Products' Technical Service Department at 1-866-672-6040. When calling, please have your model and serial numbers of your heater ready.

You can also visit DESA Heating Products' technical services web site at [www.desatech.com](http://www.desatech.com).

## TROUBLESHOOTING

*Note:* For additional help, visit DESA Heating Products' technical service web site at [www.desatech.com](http://www.desatech.com).

*Note:* All troubleshooting items are listed in order of operation.

**⚠ WARNING:** Turn off heater and let cool before servicing. Only a qualified service person should service and repair heater.

**⚠ CAUTION:** Never use a wire, needle, or similar object to clean ODS/pilot. This can damage ODS/pilot unit.

OBSERVED PROBLEM	POSSIBLE CAUSE	REMEDY
When ignitor button is pressed, there is no spark at ODS/pilot	<ol style="list-style-type: none"> <li>1. Ignitor electrode not connected to ignitor cable</li> <li>2. Ignitor cable pinched or wet</li> <li>3. Piezo ignitor nut is loose</li> <li>4. Broken ignitor cable</li> <li>5. Bad piezo ignitor</li> <li>6. Ignitor electrode broken</li> <li>7. Ignitor electrode positioned wrong</li> </ol>	<ol style="list-style-type: none"> <li>1. Reconnect ignitor cable</li> <li>2. Free ignitor cable if pinched by any metal or tubing. Keep ignitor cable dry</li> <li>3. Tighten nut holding piezo ignitor to base panel of log set. Nut is located behind base panel</li> <li>4. Replace ignitor cable</li> <li>5. Replace piezo ignitor</li> <li>6. Replace pilot assembly</li> <li>7. Replace pilot assembly</li> </ol>
When ignitor button is pressed, there is spark at ODS/pilot but no ignition	<ol style="list-style-type: none"> <li>1. Gas supply turned off or equipment shutoff valve closed</li> <li>2. Control knob not in PILOT position</li> <li>3. Control knob not pressed in while in PILOT position</li> <li>4. Air in gas lines when installed</li> <li>5. Depleted gas supply (propane/LP only)</li> <li>6. ODS/pilot is clogged</li> <li>7. Gas regulator setting is not correct</li> </ol>	<ol style="list-style-type: none"> <li>1. Turn on gas supply or open equipment shutoff valve</li> <li>2. Turn control knob to PILOT position</li> <li>3. Press in control knob while in PILOT position</li> <li>4. Continue holding down control knob. Repeat igniting operation until air is removed</li> <li>5. Contact local propane/LP gas company</li> <li>6. Clean ODS/pilot (see <i>Cleaning and Maintenance</i>, pages 17 and 18) or replace ODS/pilot assembly</li> <li>7. Replace gas control</li> </ol>
ODS/pilot lights but flame goes out when control knob is released	<ol style="list-style-type: none"> <li>1. Control knob not fully pressed in</li> <li>2. Control knob not pressed in long enough</li> <li>3. Equipment shutoff valve not fully open</li> <li>4. Pilot flame not touching thermocouple, which allows thermocouple to cool, causing pilot flame to go out. This problem could be caused by one or both of the following: <ol style="list-style-type: none"> <li>A) Low gas pressure</li> <li>B) Dirty or partially clogged ODS/pilot</li> </ol> </li> <li>5. Thermocouple connection loose at control valve</li> <li>6. Thermocouple damaged</li> <li>7. Control valve damaged</li> </ol>	<ol style="list-style-type: none"> <li>1. Press in control knob fully</li> <li>2. After ODS/pilot lights, keep control knob pressed in 30 seconds</li> <li>3. Fully open equipment shutoff valve</li> <li>4. A) Contact local natural or propane/LP gas company <ol style="list-style-type: none"> <li>B) Clean ODS/pilot (see <i>Cleaning and Maintenance</i>, pages 17 and 18) or replace ODS/pilot assembly</li> </ol> </li> <li>5. Hand tighten until snug, then tighten 1/4 turn more</li> <li>6. Replace pilot assembly</li> <li>7. Replace control valve</li> </ol>

For more information, visit [www.desatech.com](http://www.desatech.com)



## TROUBLESHOOTING

### Continued

OBSERVED PROBLEM	POSSIBLE CAUSE	REMEDY
Burner does not light after ODS/pilot is lit	<ol style="list-style-type: none"> <li>1. Burner orifice clogged</li> <li>2. Inlet gas pressure is too low</li> </ol>	<ol style="list-style-type: none"> <li>1. Clean burner (see <i>Cleaning and Maintenance</i>, pages 17 and 18) or replace burner orifice</li> <li>2. Contact local natural or propane/LP gas company</li> </ol>
Delayed ignition burner	<ol style="list-style-type: none"> <li>1. Manifold pressure is too low</li> <li>2. Burner orifice clogged</li> </ol>	<ol style="list-style-type: none"> <li>1. Contact local natural or propane/LP gas company</li> <li>2. Clean burner (see <i>Cleaning and Maintenance</i>, pages 17 and 18) or replace burner orifice</li> </ol>
Burner backfiring during combustion	<ol style="list-style-type: none"> <li>1. Burner orifice is clogged or damaged</li> <li>2. Damaged burner</li> <li>3. Gas regulator defective</li> </ol>	<ol style="list-style-type: none"> <li>1. Clean burner (see <i>Cleaning and Maintenance</i>, pages 17 and 18) or replace burner orifice</li> <li>2. Replace damaged burner</li> <li>3. Replace gas control</li> </ol>
Slight smoke or odor during initial operation	<ol style="list-style-type: none"> <li>1. Not enough air</li> <li>2. Gas regulator defective</li> <li>3. Residues from manufacturing processes and logs curing</li> </ol>	<ol style="list-style-type: none"> <li>1. Check burner for dirt and debris. If found, clean burner (see <i>Cleaning and Maintenance</i>, pages 17 and 18)</li> <li>2. Replace gas control</li> <li>3. Problem will stop after a few hours of operation</li> </ol>
Moisture/condensation noticed on windows	<ol style="list-style-type: none"> <li>1. Not enough combustion/ventilation air</li> </ol>	<ol style="list-style-type: none"> <li>1. Refer to <i>Air for Combustion and Ventilation</i> requirements (page 4)</li> </ol>
Heater produces a whistling noise when burner is lit	<ol style="list-style-type: none"> <li>1. Turning control knob to HI position when burner is cold</li> <li>2. Air in gas line</li> <li>3. Air passageways on heater blocked</li> <li>4. Dirty or partially clogged burner orifice</li> </ol>	<ol style="list-style-type: none"> <li>1. Turn control knob to LO position and let warm up for a minute</li> <li>2. Operate burner until air is removed from line. Have gas line checked by local natural or propane/LP gas company</li> <li>3. Observe minimum installation clearances (see pages 7 through 9)</li> <li>4. Clean burner (see <i>Cleaning and Maintenance</i>, pages 17 and 18) or replace burner orifice</li> </ol>
White powder residue forming within burner box or on adjacent walls or furniture	<ol style="list-style-type: none"> <li>1. When heated, vapors from furniture polish, wax, carpet cleaners, etc. may turn into white powder residue</li> </ol>	<ol style="list-style-type: none"> <li>1. Turn heater off when using furniture polish, wax, carpet cleaners, or similar products</li> </ol>

## TROUBLESHOOTING

*Continued*

- ⚠ WARNING: If you smell gas**
- Shut off gas supply.
  - Do not try to light any appliance.
  - Do not touch any electrical switch; do not use any phone in your building.
  - Immediately call your gas supplier from a neighbor's phone. Follow the gas supplier's instructions.
  - If you cannot reach your gas supplier, call the fire department.

**IMPORTANT:** Operating heater where impurities in air exist may create odors. Cleaning supplies, paint, paint remover, cigarette smoke, cements and glues, new carpet or textiles, etc., create fumes. These fumes may mix with combustion air and create odors. These odors will disappear over time.

OBSERVED PROBLEM	POSSIBLE CAUSE	REMEDY
Heater produces a clicking/ticking noise just after burner is lit or shut off	1. Metal expanding while heating or contracting while cooling	1. This is common with most heaters. If noise is excessive, contact qualified service person
Heater produces unwanted odors	1. Heater burning vapors from paint, hair spray, glues, cleaners, chemicals, new carpet, etc. (See <b>IMPORTANT</b> statement above) 2. Gas leak. <b>See Warning statement at top of page</b>	1. Open window and ventilate room. Stop using odor causing products while heater is running 2. Locate and correct all leaks (see <i>Checking Gas Connections</i> , page 14)
Heater shuts off in use (ODS operates)	1. Not enough fresh air is available 2. Low line pressure  3. ODS/pilot is partially clogged	1. Open window and/or door for ventilation 2. Contact local natural or propane/LP gas company 3. Clean ODS/pilot (see <i>Cleaning and Maintenance</i> , pages 17 and 18)
Gas odor even when control knob is in OFF position	1. Gas leak. <b>See Warning statement at top of page</b> 2. Control valve defective	1. Locate and correct all leaks (see <i>Checking Gas Connections</i> , pages 14 and 15) 2. Replace control valve
Gas odor during combustion	1. Foreign matter between control valve and burner 2. Gas leak. <b>See Warning statement at top of page</b>	1. Take apart gas tubing and remove foreign matter 2. Locate and correct all leaks (see <i>Checking Gas Connections</i> , pages 14 and 15)

For more information, visit [www.desatech.com](http://www.desatech.com)



## ILLUSTRATED PARTS BREAKDOWN

MODELS CF26PT (SHOWN)  
AND CF26NT

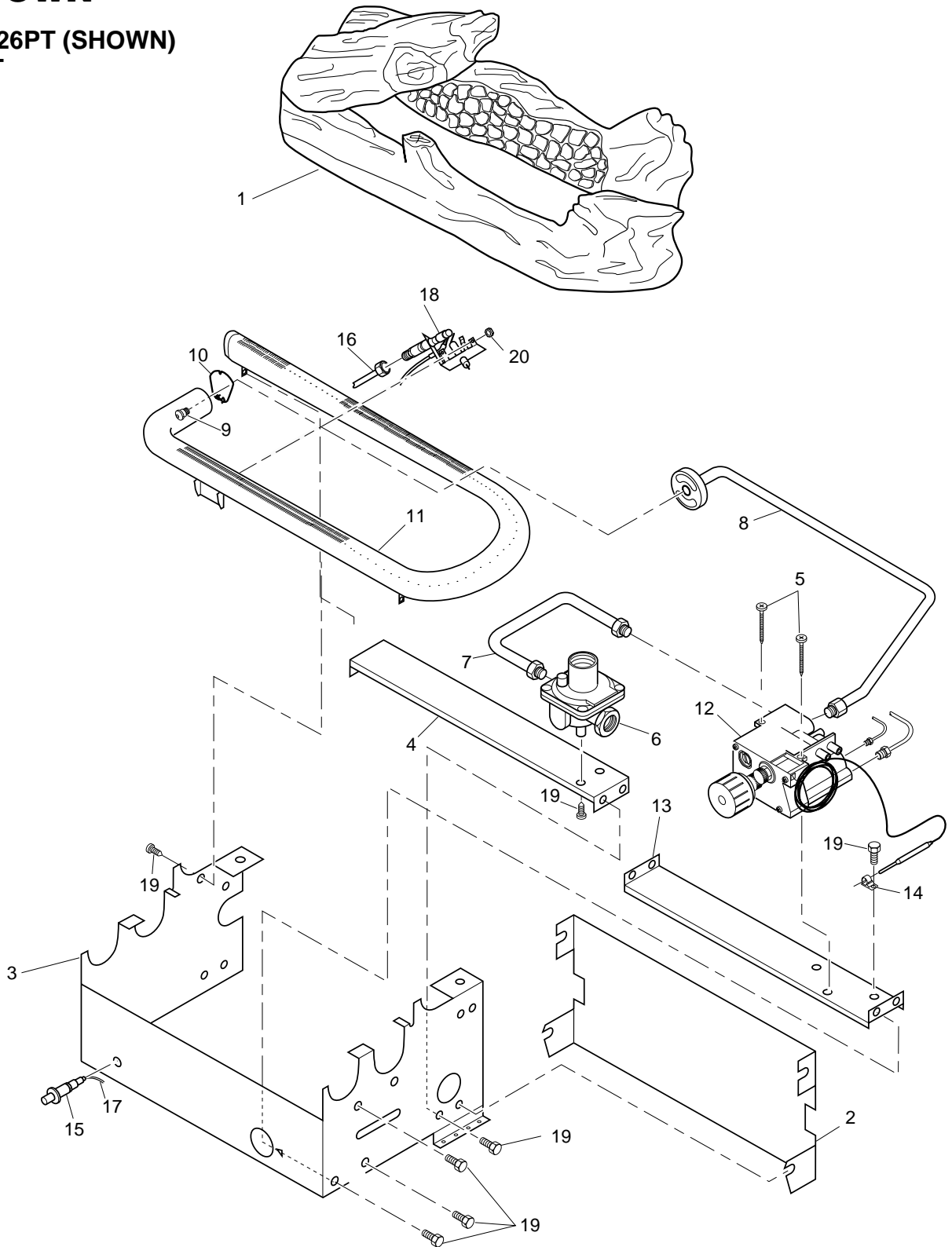

**For more information, visit [www.desatech.com](http://www.desatech.com)**

## PARTS LIST

This list contains replaceable parts used in your heater. When ordering parts, follow the instructions listed under *Replacement Parts* on page 26 of this manual.

KEY NO.	PART NUMBER		DESCRIPTION	QTY.
	CF26PT	CF26NT		
1	106039-01	106039-01	Log Set	1
2	104033-03	104033-03	Baffle, Rear	1
3	102776-07	102776-07	Base Assembly	1
4	102844-02	102844-02	Lower Bracket	1
5	099211-01	099211-01	Screw, 10-16 x 2.50	2
6	098867-10	098867-14	Gas Regulator	1
7	102981-01	102981-01	Inlet Tube	1
8	102983-06	111331-08	Outlet Burner Tube	1
9	099056-29	099056-20	Burner Orifice Injector	1
10	111124-01	111124-01	Burner Retainer Spring	1
11	102980-01	102980-01	Burner	1
12	101329-22	101329-21	Thermostat Gas Valve Assembly	1
13	102979-02	102979-02	Thermostat Bracket	1
14	098544-01	098544-01	Thermostat Clip	1
15	102445-01	102445-01	Piezo Ignitor	1
16	099387-09	099387-09	Pilot Tube	1
17	098271-10	098271-10	Ignitor Cable	1
18	104286-01	104285-01	ODS Pilot	1
19	M11084-38	M11084-38	Hex Screw, #8-18 x .38	12
20	098249-01	098249-01	Nut, M5	2

**ILLUSTRATED PARTS  
BREAKDOWN**

MODELS CF26PT AND CF26NT

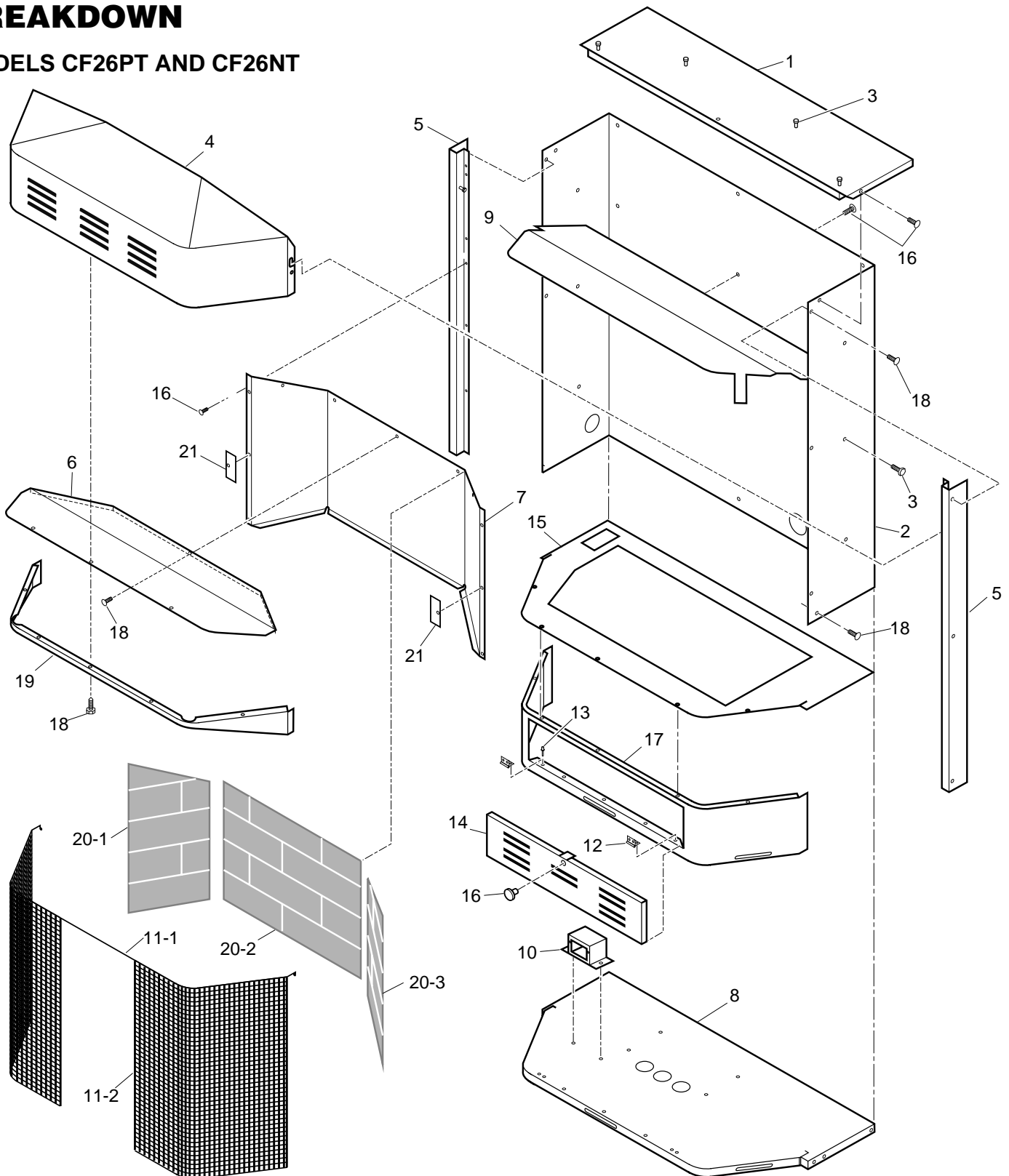
**For more information, visit [www.desatech.com](http://www.desatech.com)**



# PARTS LIST

## MODELS CF26PT AND CF26NT

This list contains replaceable parts used in your fireplace. When ordering parts, follow the instructions listed under *Replacement Parts* on page 26 of this manual.

KEY NO.	PART NO.	DESCRIPTION	QTY.
1	102633-02	Outer Casing Top	1
2	102624-02	Outer Casing	1
3	099230-02	Shoulder Screw	12
4	105631-01CK	Assy. Hood Weldment	1
5	105258-01CK	Vertical Front, Left and Right Sides	2
6	105259-01	Firebox Top	1
7	**	Firebox Wrapper	1
8	**	Bayfront Base	1
9	105421-01	Heat Deflector	1
10	105409-01	Fan Control Shield	1
11-1	105401-01	Screen Rod	1
11-2	105440-01	Screen Assembly	1
12	101386-02	Hinge	2
13	**	Rivets	8
14	105262-01CK	Louvered Door	1
15	**	Firebox Floor	1
16	098304-01	Screw, #10 x 3/8"	21
17	105256-01CK	Bayfront Bottom Panel	1
18	M11084-26	Hex Head Screws #10 x .38	26
19	105513-01CK	Cover, Screen Rod	1
20-1	105525-01	Fiber Brick, Left	1
20-2	105524-01	Fiber Brick, Rear	1
20-3	105526-01	Fiber Brick, Right	1
21	105987-01	Brick Liner Retainer	2
<b>PARTS AVAILABLE — NOT SHOWN</b>			
	101054-01	Lighting Instructions Plate	1
	100563-01	Warning Plate	1
	103470-01	Hardware Package	1

\*\* Not a field replaceable part.

## REPLACEMENT PARTS

*Note:* Use only original replacement parts. This will protect your warranty coverage for parts replaced under warranty.

### PARTS UNDER WARRANTY

Contact authorized dealers of this product. If they can't supply original replacement part(s) call DESA Heating Products' Technical Service Department at 1-866-672-6040 for referral information.

When calling DESA Heating Products, have ready

- your name
- your address
- model and serial numbers of your fireplace
- how fireplace was malfunctioning
- type of gas used (propane/LP or natural gas)
- purchase date

Usually, we will ask you to return the part to the factory.

## PARTS CENTRALS

These Parts Centrals are privately owned businesses. They have agreed to support our customer's needs by providing original replacement parts and accessories.

### Baltimore Electric

1348 Dixwell Avenue  
Hamden, CT 06514-0322  
1-800-397-7553  
203-248-7553  
Parts Department

### Portable Heater Parts

342 N. County Rd. 400 East  
Valparaiso, IN 46383-9704  
All States  
219-462-7441  
1-888-619-7060  
Parts Department  
sales@portableheaterparts.com  
techservice@portableheaterparts.com

### FBD

1349 Adams St.  
Bowling Green, KY 42103-3413  
270-846-1199  
1-800-654-8534  
Fax: 1-800-846-0090  
franktalk@aol.com

### Master Parts Distributors

1251 Mound Ave. NW  
Grand Rapids, MI 49504-2672  
616-791-0505  
1-800-446-1446  
Fax: 616-791-8270  
www.nbmc.com

### Washer Equipment Co.

1715 Main Street  
Kansas City, MO 64108-2195  
KS, MO, AR  
816-842-3911  
www.washerparts.com

### East Coast Energy Products

707 Broadway  
W. Long Branch, NJ 07764-1542  
732-870-8809  
1-800-755-8809  
www.njplaza.com/ecep

### Laportes Parts & Service

2444 N. 5th Street  
Hartsville, SC 29550-7704  
843-332-0191  
Parts Department

### Cans Unlimited, Inc.

P.O. Box 645  
Taylor, SC 29687-0013  
All States  
803-879-3009  
1-800-845-5301  
cuisales@aol.com

### PARTS NOT UNDER WARRANTY

Contact authorized dealers of this product or Parts Central (see below). If they can't supply original replacement part(s) call DESA Heating Products at 1-866-672-6040 for referral information.

When calling DESA Heating Products, have ready

- model number of your fireplace
- the replacement part number

# OWNER'S REGISTRATION FORM

In order to provide better customer service for this and future purchases, we recommend that you register your product with us. You can register online at [www.desatech.com](http://www.desatech.com). If access to our website is not available to you, please complete this Owner's Registration Form and mail to the address on the back of this owner's manual. Please provide the following product information:

Brand: \_\_\_\_\_ (Comfort Glow, Vanguard, etc.)  
 Model: \_\_\_\_\_ (EFP33PR, VTGH33NR, etc.)  
 Date Purchased: \_\_\_\_\_ *Note: Keep receipt for warranty verification.*  
 Serial Number: \_\_\_\_\_ 7 or 9 digit number located on product or identification tag.  
 First Name: \_\_\_\_\_ Last Name: \_\_\_\_\_  
 Address: \_\_\_\_\_  
 City: \_\_\_\_\_ State: \_\_\_\_\_ Zip: \_\_\_\_\_ Country: \_\_\_\_\_  
 Home Phone: \_\_\_\_\_  
 E-Mail: \_\_\_\_\_

Please answer the following questions to register your product with DESA Heating Products:

1. Where will the product be used?  
 Living/Family Room  Office/Warehouse  Utility Shed/Outbuilding  Garage  Bedroom  Bathroom  Other
2. If you bought this product yourself, did you plan to purchase this type of product before going into the store?  Yes  No
3. Who selected the product?  Male  Female  Both
4. What is the population of your area?  Under 10,000  10,000 to 25,000  25,000 to 50,000  50,000 to 100,000  
 100,000 to 250,000  Over 250,000
5. What is your primary source of heat?  Propane (LP Gas)  Fuel Oil  Wood  Natural Gas  Electric  Other
6. How was the product installed?  Professional Installer  Self  Other
7. Cost of product excluding sales tax? \$ \_\_\_\_\_
8. Cost to install product? \$ \_\_\_\_\_
9. Type of store where product was purchased?  Hardware  Propane Dealer  Natural Gas/Utility Co.  Home Center/Builder's Supply  
 Fireplace or Hearth Shop  Farm Store  Other
10. What motivated you to buy this product?  Sudden Cold Weather  Replace Older Model  D.I.Y. Home Project  
 Emergency Back-Up Heat  Heater was on Sale  Energy Savings/High Efficiency  Construction Project  Other
11. How did you learn about this product brand?  Advertising  Relative or Friend  Store Display  Other \_\_\_\_\_
12. Level of Education of Purchaser:  Some High School  Completed High School  Completed College  Completed Graduate School
13. Age of Purchaser:  Under 20  20 - 29  30 - 39  40 - 49  50 - 59  60 or Over
14. Buyer's total annual household income:  Under \$15,000  \$15,000 to \$19,999  \$20,000 to \$34,999  \$35,000 to \$49,999  
 \$50,000 to \$74,999  \$75,000 to \$99,999  \$100,000 and Over
15. Store where product was purchased:  
 Name: \_\_\_\_\_  
 City: \_\_\_\_\_ State: \_\_\_\_\_

16. In choosing this product, how important were the following:

	Not Important	Somewhat Important	Very Important
Availability	<input type="radio"/>	<input type="radio"/>	<input type="radio"/>
Price	<input type="radio"/>	<input type="radio"/>	<input type="radio"/>
Brand Name	<input type="radio"/>	<input type="radio"/>	<input type="radio"/>
Overall Quality	<input type="radio"/>	<input type="radio"/>	<input type="radio"/>
Heat Output	<input type="radio"/>	<input type="radio"/>	<input type="radio"/>
Made in USA	<input type="radio"/>	<input type="radio"/>	<input type="radio"/>
Warranty	<input type="radio"/>	<input type="radio"/>	<input type="radio"/>
Local Service	<input type="radio"/>	<input type="radio"/>	<input type="radio"/>
Value for Price	<input type="radio"/>	<input type="radio"/>	<input type="radio"/>
Prior Brand Experience	<input type="radio"/>	<input type="radio"/>	<input type="radio"/>
Controls Location	<input type="radio"/>	<input type="radio"/>	<input type="radio"/>
Thermostat, Remote, or Manual Operation	<input type="radio"/>	<input type="radio"/>	<input type="radio"/>
Ease of Operation	<input type="radio"/>	<input type="radio"/>	<input type="radio"/>
Special Features	<input type="radio"/>	<input type="radio"/>	<input type="radio"/>
Salesperson's Recommendation	<input type="radio"/>	<input type="radio"/>	<input type="radio"/>
Friend/Relative's Recommendation	<input type="radio"/>	<input type="radio"/>	<input type="radio"/>
Portability	<input type="radio"/>	<input type="radio"/>	<input type="radio"/>
Quiet Operation	<input type="radio"/>	<input type="radio"/>	<input type="radio"/>

TAPE

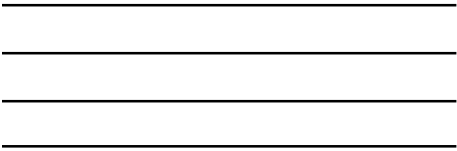

Postage  
Required

**DESA**<sup>TM</sup>  
**HEATING PRODUCTS**  
2701 Industrial Drive  
P.O. Box 90004  
Bowling Green, KY 42102-9004

TAPE

## ACCESSORIES

Purchase these fireplace accessories from your local dealer or Parts Central (see page 26). If they cannot supply these accessories call DESA Heating Products' Sales Department at 1-866-672-6040 for referral information. You can also write to the address listed on the back page of this manual.

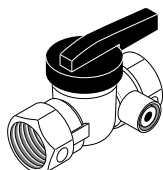

### EQUIPMENT SHUTOFF VALVE - GA5010

Equipment shutoff valve with 1/8" NPT tap.

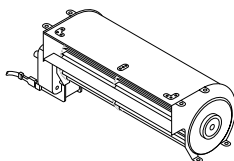

### THERMOSTATICALLY CONTROLLED BLOWER KIT - GA3450T

Provides better heat distribution. Blower turns off and on automatically, as needed. Complete installation and operating instructions included.

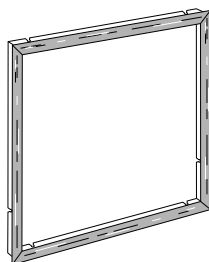

### BRASS ACCENT TRIM - GA6095

Optional four-sided trim kit for built-in installations. Provides a finished appearance covering rough edges of wall opening.

### BRASS ACCENT TRIM - GA7092 (Not Shown)

Optional two piece trim kit for the Bayfront Fireplace. Easily screws to fireplace front. Provides an upscale appearance.

### CLEANING KIT - CCK (Not Shown)

Your vent-free gas appliance requires regular cleaning and maintenance to prevent performance problems. This kit gives you the tools and instructions to make it easy to clean all critical areas of your appliance.

### CABINET MANTEL WITH BUILT-IN HEARTH BASE

Unfinished Hardwood Veneer  
GMC46U

White Lacquer Finish  
GMC47W

Medium Stained Oak Veneer  
GMC45F

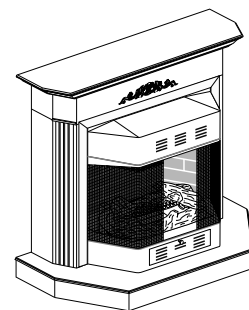

For use with fireplace. A hardwood mantel and hearth base offers compact styling and completes the fireplace look. Available in a white lacquer finish, medium stained oak, or an unfinished hardwood, ready to stain or paint. Complete assembly instructions included. Three-sided trim kit included.

### CABINET MANTEL WITH FULL HEARTH BASE

Stained Oak Veneer  
GMC60F

Walnut Stained Birch  
Veneer - GMC62F

Unfinished Birch Veneer  
GMC61U

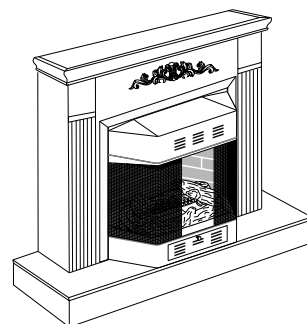

The hardwood mantel and full hearth base feature fluted legs and crown molding. Available in medium stained oak, walnut stained hardwood, and unfinished hardwood, ready to stain or paint. Complete assembly instructions included. Three-sided trim kit included.

### CORNER MANTEL WITH FULL HEARTH BASE

Stained Oak Veneer  
GMC64F

Unfinished Birch Veneer  
GMC63U

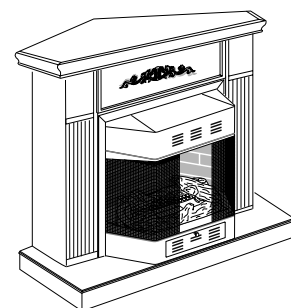

Space-saving mantel and full hearth base corner design offers classic styling. Available in stained oak or unfinished hardwood, ready to stain or paint. Complete assembly instructions included. Three-sided trim kit included.

### INFORMATION VIDEO - 108917-01

A care and maintenance video is available by calling 1-866-672-6040. You may also email your request to [productsupport@desaint.com](mailto:productsupport@desaint.com).

For more information, visit [www.desatech.com](http://www.desatech.com)



# WARRANTY INFORMATION

## KEEP THIS WARRANTY

Model _____
Serial No. _____
Date Purchased _____

Always specify model and serial numbers when communicating with the factory.

We reserve the right to amend these specifications at any time without notice. The only warranty applicable is our standard written warranty. We make no other warranty, expressed or implied.

### LIMITED WARRANTY VENT-FREE GAS BAY FRONT FIREPLACE

DESA Heating Products warrants this product to be free from defects in materials and components for two (2) years from the date of first purchase, provided that the product has been properly installed, operated and maintained in accordance with all applicable instructions. To make a claim under this warranty the Bill of Sale or cancelled check must be presented.

This warranty is extended only to the original retail purchaser. This warranty covers the cost of part(s) required to restore this fireplace to proper operating condition and an allowance for labor when provided by a DESA Heating Products Authorized Service Center. Warranty part(s) MUST be obtained through authorized dealers of this product and/or DESA Heating Products who will provide original factory replacement parts. Failure to use original factory replacement parts voids this warranty. The fireplace MUST be installed by a qualified installer in accordance with all local codes and instructions furnished with the unit.

This warranty does not apply to parts that are not in original condition because of normal wear and tear, or parts that fail or become damaged as a result of misuse, accidents, lack of proper maintenance or defects caused by improper installation. Travel, diagnostic cost, labor, transportation and any and all such other costs related to repairing a defective fireplace will be the responsibility of the owner.

TO THE FULL EXTENT ALLOWED BY THE LAW OF THE JURISDICTION THAT GOVERNS THE SALE OF THE PRODUCT; THIS EXPRESS WARRANTY EXCLUDES ANY AND ALL OTHER EXPRESSED WARRANTIES AND LIMITS THE DURATION OF ANY AND ALL IMPLIED WARRANTIES, INCLUDING WARRANTIES OF MERCHANTABILITY AND FITNESS FOR A PARTICULAR PURPOSE TO TWO (2) YEARS ON ALL COMPONENTS FROM THE DATE OF FIRST PURCHASE; AND DESA HEATING PRODUCTS' LIABILITY IS HEREBY LIMITED TO THE PURCHASE PRICE OF THE PRODUCT AND DESA HEATING PRODUCTS SHALL NOT BE LIABLE FOR ANY OTHER DAMAGES WHATSOEVER INCLUDING INDIRECT, INCIDENTAL OR CONSEQUENTIAL DAMAGES.

Some states do not allow a limitation on how long an implied warranty lasts or an exclusion or limitation of incidental or consequential damages, so the above limitation on implied warranties, or exclusion or limitation on damages may not apply to you.

This warranty gives you specific legal rights, and you may also have other rights that vary from state to state.

For information about this warranty write:

**DESA**  
HEATING PRODUCTS™  
2701 Industrial Drive  
P.O. Box 90004  
Bowling Green, KY 42102-9004  
www.desatech.com



111410 01

NOT A UPC

111410-01  
Rev. C  
06/03

**For more information, visit [www.desatech.com](http://www.desatech.com)**

## Free Manuals Download Website

<http://myh66.com>

<http://usermanuals.us>

<http://www.somanuals.com>

<http://www.4manuals.cc>

<http://www.manual-lib.com>

<http://www.404manual.com>

<http://www.luxmanual.com>

<http://aubethermostatmanual.com>

Golf course search by state

<http://golfingnear.com>

Email search by domain

<http://emailbydomain.com>

Auto manuals search

<http://auto.somanuals.com>

TV manuals search

<http://tv.somanuals.com>