

Gefen[®]

8x4 Matrix for HDMI[™]

EXT-HDMI-844

User Manual



www.gefen.com

Download from www.Softpedia.com. All Manuals Search And Download.

ASKING FOR ASSISTANCE

Technical Support:

Telephone (818) 772-9100
(800) 545-6900

Fax (818) 772-9120

Technical Support Hours:

8:00 AM to 5:00 PM Monday thru Friday Pacific Time

Write To:

Gefen Inc.
c/o Customer Service
20600 Nordhoff St
Chatsworth, CA 91311

www.gefen.com
support@gefen.com

Notice

Gefen Inc. reserves the right to make changes in the hardware, packaging and any accompanying documentation without prior written notice.

8x4 Matrix for HDMI is a trademark of Gefen Inc.

© 2010 Gefen Inc., All Rights Reserved
All trademarks are the property of their respective owners

Rev A2

CONTENTS

- 1 Introduction**
- 2 Operation Notes**
- 3 Features**
- 4 Panel Layout**
- 5 Panel Descriptions**
- 6 Connecting And Operating The 8X4 Matrix For HDMI**
- 7 LED Array**
- 8 RMT-16IR Remote Description**
- 9 IR Code Configuration**
- 10 EDID Management Feature**
- 11 EDID Management Modes**
- 12 RS-232 Serial Communications**
- 13 RS-232 Serial Communications Commands**
- 14 Specifications**
- 15 Warranty**

INTRODUCTION

Congratulations on your purchase of the 8x4 Matrix for HDMI. Your complete satisfaction is very important to us.

Gefen

Gefen delivers innovative, progressive computer and electronics add-on solutions that harness integration, extension, distribution and conversion technologies. Gefen's reliable, plug-and-play products supplement cross-platform computer systems, professional audio/video environments and HDTV systems of all sizes with hard-working solutions that are easy to implement and simple to operate.

The Gefen 8x4 Matrix for HDMI

The rack-mountable 8x4 Matrix for HDMI sends high definition video and multichannel digital audio from any of 8 HDMI sources to any 4 Displays. The HDMI inputs consist of 4 High Definition video switches that can each accept 2 video sources. This input scheme allows up to 8 sources to be available while viewing any 4 on the output displays concurrently.

The 8x4 Matrix for HDMI eliminates the need to disconnect and reconnect sources to displays. It works with Blu-Ray players, Set-Top boxes, Home Theater PCs, and game consoles that connect to an HDMI display. Any source is accessible at all times by any display by selecting it using an IR remote or an RS-232 remote control device. The Matrix comes with rack ears for mounting in a shelving system.

How It Works

Up to 8 HDMI sources (4 viewable at any one time) connect to the Matrix's inputs and up to four Displays connect to the Matrix's outputs. Power up the 8x4 Matrix, HDMI sources and all connected Displays. Select which HDMI sources you want to view on each display using the IR remote. The result will be clear and vibrant HDMI video with multichannel digital audio at each Display.

OPERATION NOTES

READ THESE NOTES BEFORE INSTALLING OR OPERATING THE 8X4 MATRIX FOR HDMI

- **Important Note:** The 8x4 Matrix for HDMI incorporates a 2x1 switch in front of each input on a traditional 4x4 matrix. This allows for the connection of up to 8 different HDMI source devices with a maximum of 4 sources available for viewable at any one time. Each of the 4 switched inputs on the 8x4 Matrix for HDMI are labeled as "A" and "B". Both "A" and "B" for each input cannot be active at the same time.

Example A (Multiple outputs viewing the same input source)

Devices: **1A** (DVD player) & **1B** (Cable STB)

Scenario: Outputs 1 and 2 are both viewing input **1A** (DVD).

Action: User viewing output 1 switches the input from **1A** (DVD) to **1B** (STB).

Result: Both outputs 1 and 2 will be switched to viewing **1B** (STB).

Example B (Multiple outputs viewing separate input sources)

Devices: **1A** (DVD player), **1B** (Cable STB), and **2A** (Video Game system)

Scenario: Output 1 is viewing **1A** and output 2 is viewing **2A**.

Action: User viewing output 1 switches the input from **1A** (DVD) to **1B** (STB).

Result: Output 2 is not affected by the change of **1A** to **1B** because it is viewing a source (**2A**) on a different input.

- Display information (EDID) from the displays attached to the 8x4 Matrix for HDMI need to be sent back to the input sources. Please see page 10 for EDID management features and options.
- HDMI 1.2 compliant (HDMI 1.3 compatible)
- HDCP compliant

FEATURES

Features

- Switches any eight HDMI™ sources to 4 Displays
- Distributes any of the four switched inputs (total of eight inputs) to any combination of the four HDMI™ output displays
- Maintains high resolution video - beautiful, sharp HDTV resolutions up to 1080p, 2k, and computer resolutions up to 1920 x 1200 are easily achieved
- Serial RS-232 remote port for switching via control automation
- HDMI™ 1.2 Compliant (HDMI 1.3 Compatible); HDCP Compliant
- Discrete IR remote (included)
- Rack ears included

Package Includes

- (1) 8x4 HDMI Matrix
- (1) RMT-16IR Remote Control
- (8) 6-Foot HDMI Cable (M-M)
- (1) 24V DC Power Supply
- (1) User's Manual
- (1) Rack Ears (set)

PANEL LAYOUT

Front Panel

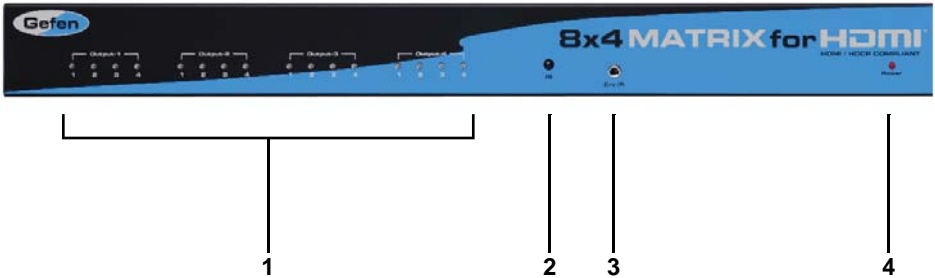

Back Panel

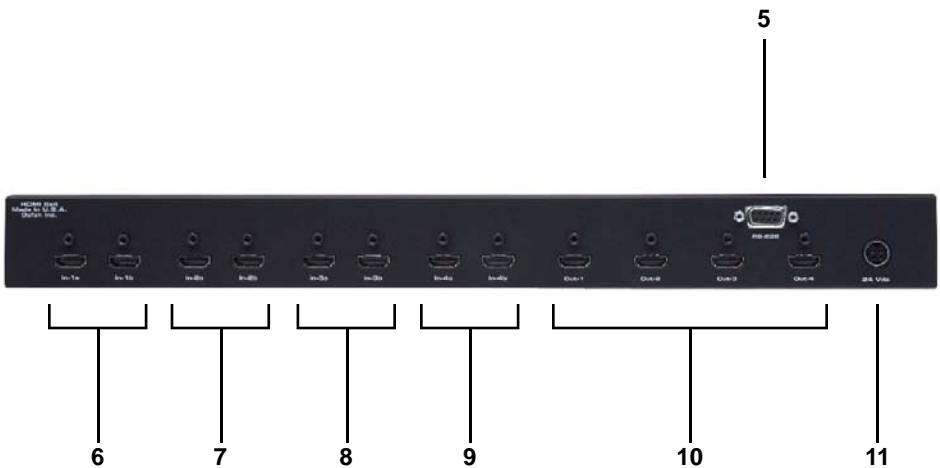

PANEL DESCRIPTIONS

1 Selected Input LED Indicator

Each of the 4 outputs has an 4 LED array to indicate which source is currently selected on the 8x4 Matrix for HDMI. Each of the inputs can accept up to 2 sources (A and B) and the LED array will behave in 2 modes to indicate which of the two sources for input is selected. Please see the operation section for a complete description on how the LED array functions.

2 IR (Infrared) Receiver

This receiver will accept command for switching between input HDMI devices using the included RMT-16IR remote control. Line of sight must be preserved for proper operation.

3 IR (Infrared) Receiver Extension

An optional IR Receiver Extension (part # EXT-RMT-EXTIR) can be connected if the unit is placed in a location that will not provide line of sight to the included IR remote control. The IR extension can then be placed in a location where it can receive commands from the IR remote control.

4 Power LED Indicator

This LED will become active once the included 24V DC power supply is properly connected between the unit and an open wall power socket.

5 RS-232 Serial Communications Port

This port is used to control multiple functions available on the 8x4 Matrix for HDMI. Please see page 12 for complete details on the serial communication features that are used on this product.

6 HDMI 1 Inputs

There are two inputs, labeled 1A and 1B, that will accept an HDMI source device. Only one of these inputs can be active at any given time.

7 HDMI 2 Inputs

There are two inputs, labeled 2A and 2B, that will accept an HDMI source device. Only one of these inputs can be active at any given time.

8 HDMI 3 Inputs

There are two inputs, labeled 3A and 3B, that will accept an HDMI source device. Only one of these inputs can be active at any given time.

9 HDMI 4 Inputs

There are two inputs, labeled 4A and 4B, that will accept an HDMI source device. Only one of these inputs can be active at any given time.

10 HDMI Outputs 1 to 4

Connect up to 4 HDMI capable devices (i.e. display) to these output ports.

11 24V DC Power Receptacle

Connect the included 24V DC power supply between this input and an open wall power socket.

CONNECTING AND OPERATING THE 8X4 MATRIX FOR HDMI

How to Connect the 8x4 Matrix for HDMI

1. Connect up to 8 HDMI source devices to the 8x4 Matrix for HDMI using the included HDMI cables.

NOTE: Please be aware that each input has two available HDMI ports and that only one will be active at any given time. It is recommended that commonly used HDMI sources be put on separate inputs (i.e. 1A and 2A, not 1A and 1B) so that these devices are always available.

2. Connect up to 4 HDMI capable devices (i.e. displays) to the 8x4 Matrix for HDMI using user supplied HDMI cables.
3. Connect the included 24V DC power supply between the power input on the unit and an open wall power socket.
4. Power on all output devices first and the source devices second.

How to Operate the 8x4 Matrix for HDMI

The 8x4 Matrix for HDMI can be controlled by either the included RMT16-IR remote control or the RS-232 serial communications port.

For RMT-16IR remote control functions please see page 8.

For RS-232 serial communication functions please see page 12.

LED ARRAY

The LED array on the 8x4 Matrix for HDMI is designed to inform the user of the current source to output routes. Each output has a 4 LED array that will indicate which source is currently selected. Each input can accept two sources and therefore the LED array will act differently according to which input, "A" or "B", is active for each.

- An input's "A" source will be indicated by a single LED (the selected "A" input) that is ON.
- An input's "B" source will be indicated by the reverse; a single LED will be OFF (the selected "B" input) while the remaining 3 LEDs will be ON.

The examples below will show some scenarios to illustrate the LED array functionality. Please note that it is not possible to have both "A" and "B" inputs active at the same time for any given input.

● = LED ON ○ = LED OFF

Scenario 1 ("A" Example)



Output 1 is selected to 1A

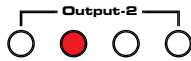

Output 2 is selected to 2A

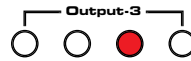

Output 3 is selected to 3A

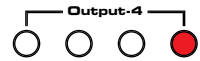

Output 4 is selected to 4A

Scenario 2 ("B" Example)

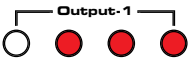

Output 1 is selected to 1B

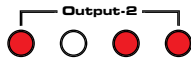

Output 2 is selected to 2B

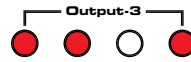

Output 3 is selected to 3B

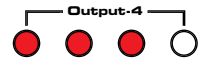

Output 4 is selected to 4B

Scenario 3 (Mixed Example)

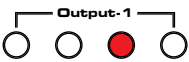

Output 1 is selected to 3A

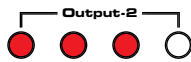

Output 2 is selected to 4B

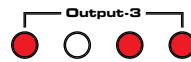

Output 3 is selected to 2A



Output 4 is selected to 1A

RMT-16IR REMOTE DESCRIPTION



The RMT-16IR remote control will allow the user to select which source will be routed to which output. Each of the 4 outputs are assigned a group of 4 buttons that will correspond to the 4 source inputs. Each button on the RMT-16IR remote control will toggle between the "A" and "B" sources for each input. Please use the information below when selecting the desired source for each display.

| RMT-16IR Button | Source | Display |
|-----------------|------------------|---------|
| 1 | Toggle 1A and 1B | 1 |
| 2 | Toggle 2A and 2B | 1 |
| 3 | Toggle 3A and 3B | 1 |
| 4 | Toggle 4A and 4B | 1 |
| 5 | Toggle 1A and 1B | 2 |
| 6 | Toggle 2A and 2B | 2 |
| 7 | Toggle 3A and 3B | 2 |
| 8 | Toggle 4A and 4B | 2 |
| 9 | Toggle 1A and 1B | 3 |
| 10 | Toggle 2A and 2B | 3 |
| 11 | Toggle 3A and 3B | 3 |
| 12 | Toggle 4A and 4B | 3 |
| 13 | Toggle 1A and 1B | 4 |
| 14 | Toggle 2A and 2B | 4 |
| 15 | Toggle 3A and 3B | 4 |
| 16 | Toggle 4A and 4B | 4 |

IR CODE CONFIGURATION

Why would I need to change the remote channel?

In some instances, the 8x4 Matrix for HDMI may use IR codes that conflict with other IR remote control devices. The unit may switch inputs when another brand IR remote control is used or the RMT-16IR may cause other brand IR controlled devices to behave unexpectedly.

I am experiencing the issues listed above. What do I do?

In these cases it is recommended to change the IR channel that the RMT-16IR remote control and the 8x4 Matrix for HDMI use. The IR channel is configured independently on the RMT-16IR remote control and the 8x4 Matrix for HDMI but the channel selection must match on both units for proper operation.

How Do I change the Remote Channel?

There are service DIP switches on the RMT-16IR remote control and also inside the 8x4 Matrix for HDMI. Use the diagrams below to locate and change the IR channel to one that is not the default. Remember that the channel must match on both the unit and remote control for successful operation.

RMT-16IR Remote Control



Remove the battery cover on the rear side of the RMT-16IR remote control to expose the DIP switches.

2 DIP switch bank for IR channel configuration.

Remote Channel 1: Default



Remote Channel 2:



Remote Channel 3:



Remote Channel 4:



8x4 Matrix for HDMI

The IR channel DIP switches for the 8x4 Matrix for HDMI are located on an 8 bank DIP switch inside of the unit and on its main-board. To open the unit, remove all screws on the underside and side of the unit. Remove all HEX screws on the rear panel. This includes the screws above each HDMI port and on each side of the RS-232 serial communications port. Carefully slide the unit apart. Locate DIP switches 3 and 4. Once adjustments are complete replace all screws and.

Remote Channel 1: Default



Remote Channel 2:



Remote Channel 3:

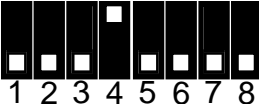

Remote Channel 4:



EDID MANAGEMENT FEATURE

EDID. What is it and what is it used for?

Under normal circumstances, a source device (digital and analog) will require information about a connected device/display to assess what resolutions and features are available. The source can then cater its output to send only resolutions and features that are compatible with the attached device/display. This information is called EDID (Extended Display Information Data) and a source device can only accept and read one EDID from a connected device/display. Likewise, the source can only output one resolution for use by a connected device/display.

Why is EDID so important with the 8x4 Matrix for HDMI?

The 8x4 Matrix is complex piece of technology that replicates and switches between multiple inputs and outputs. Each connected source device will require one EDID to read. EDID management is carefully handled by 8x4 Matrix for HDMI to provide a single EDID for each source to read.

What options do I have to manage the EDID in the 8x4 Matrix for HDMI?

First, it is important to note that each source device can only output one video/audio signal type. This includes resolutions and timings. When multiple devices/displays are used, such as with the 8x4 Matrix for HDMI, it is important to use devices/displays that have similar or compatible resolutions/features. This will ensure that the single video/audio signal produced by the source device is accepted by all of the connected output devices/displays.

The user has the option, through a combination of DIP switch settings within the 8x4 Matrix for HDMI, to choose how the unit will manage the EDID from multiple HDMI devices/displays. Therefore the user has some control over the resolutions/features that the source devices will output. The 8x4 Matrix for HDMI has a multiple EDID management modes that will control how the EDID information from multiple devices/displays are combined, ignored, and routed.

How do I change EDID modes in the 8x4 Matrix for HDMI?

There is an bank of 8 DIP switches located on the main-board inside of the 8x4 Matrix for HDMI. DIP switches 1, 2, 5, and 7 are used in different combinations to manage the EDID modes.

TIP: EDID modes and IR code channels can also be managed via the RS-232 serial communications port. For this to work, all DIP switches must be in the OFF position. This is the factory default setting. If you wish to use this feature, please do not open the unit. See page 12 for more information on the RS-232 serial communication features.

To access these DIP switches it will be required to open the unit. To do this, remove all screws on the underside and side of the unit. Remove all HEX screws on the rear panel. This includes the screws above each HDMI port and on each side of the RS-232 serial communications port. Carefully slide the unit apart.

EDID Modes

The diagram below illustrates the 8 DIP switch bank.

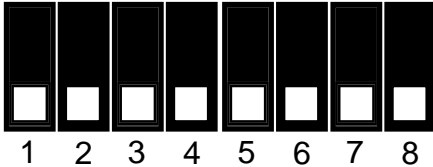

| DIP SWITCH | Function |
|------------|------------|
| 1 | EDID Mode |
| 2 | EDID Mode |
| 3 | IR Channel |
| 4 | IR Channel |
| 5 | EDID Mode |
| 6 | N/A |
| 7 | EDID Mode |
| 8 | N/A |

Use DIP switches 1, 2, 5, and 7 to select the desired EDID management mode.

EDID Mode 0 (Switch 1=OFF Switch2=OFF Switch5=ON)

- EDID is copied from the device connected to the first active hdmi output port.
- All features newer than HDMI 1.2 are cleared.

EDID Mode 1 (Switch 1=ON Switch2=OFF Switch5=ON)

- Same as Mode 0 and adds basic audio support.

EDID Mode 2 (Switch 1=OFF Switch2=ON Switch5=ON)

- Same as Mode 0 and adds full audio support.

EDID Mode 3 (Switch 1=ON Switch2=ON Switch5=OFF)

- EDID is generated based on the common video and audio features of all of the connected output devices.

EDID Mode 4 (Switch 1=OFF Switch2=ON Switch5=OFF)

- Same as Mode 3 and adds basic audio support.

EDID Mode 5 (Switch 1=ON Switch2=OFF Switch5=OFF)

- Same as Mode 3 and adds full audio support.

EDID Mode 6 (Switch 1=OFF Switch2=OFF Switch5=OFF) DEFAULT

- EDID is generated based on the common video features of all of the connected devices and the combined audio features of all of the connected output devices.

EDID Mode 7 (Switch 1=ON Switch2=ON Switch5=ON)

- EDID is passed unmodified from the device connected to the first active output port.

EDID Mode 8 (Switch 1=OFF Switch2=OFF Switch5=OFF Switch7=ON)

- Preloaded generic 1080p EDID is used.

EDID Mode A (Switch 1=OFF Switch2=ON Switch5=OFF Switch7=ON)

- Same as mode 6 but will record and store the EDID in memory. This EDID will persist no matter what displays are disconnected or reconnected thereafter. EDID will remain even upon power cycle. A user submitted EDID can be uploaded in this mode using a Gefen HDMI Signal Generator.

RS-232 SERIAL COMMUNICATIONS

What features are available via the RS-232 serial communications port?

The 8x4 Matrix for HDMI can accept commands through the RS-232 serial communications port located on the rear panel. The current RS-232 control features are:

- Switching/routing of inputs to outputs without the RMT-16IR remote control.
- Switch EDID management modes without opening the unit to physically modify DIP switches.
- Change IR code channel without opening the unit to physically modify DIP switches. (The IR code channel will still need to be manually modified on the RMT-16IR remote control to match the code channel.)

How do I use these features?

These features were initially intended for utilization by custom installers in automated setups. However, these features can be tested by using any Windows PC with the Hyperterminal program.

What pins are used for communication with the 8x4 Matrix for HDMI?

Only pins 2 (Receive), 3 (Transmit), and 5 (Ground) are used for communication. A null-modem adapter should not be used with this product.

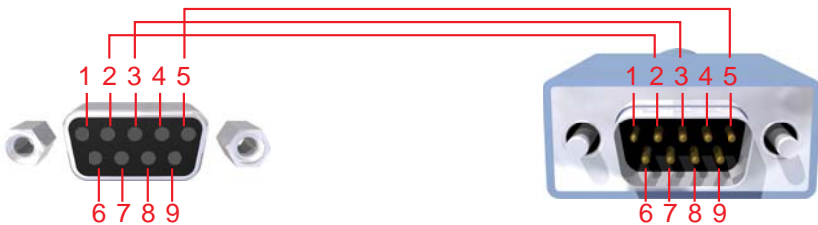

Only Pins 2 (RX), 3 (TX), and 5 (Ground) are used on the RS-232 serial interface

What are the communication port settings?

| | |
|-----------------------|-------|
| Bits per second | 19200 |
| Data bits | 8 |
| Parity | None |
| Stop bits | 1 |
| Flow Control | None |

RS-232 SERIAL COMMUNICATIONS COMMANDS

Switching/Routing Binary Table

| ASCII Command | Input | Output | ASCII Command | Input | Output |
|---------------|-------|--------|---------------|-------|--------|
| A1/a1 | 1A | 1 | C1/c1 | 1A | 3 |
| A2/a2 | 1B | 1 | C2/c2 | 1B | 3 |
| A3/a3 | 2A | 1 | C3/c3 | 2A | 3 |
| A4/a4 | 2B | 1 | C4/c4 | 2B | 3 |
| A5/a5 | 3A | 1 | C5/c5 | 3A | 3 |
| A6/a6 | 3B | 1 | C6/c6 | 3B | 3 |
| A7/a7 | 4A | 1 | C7/c7 | 4A | 3 |
| A8/a8 | 4B | 1 | C8/c8 | 4B | 3 |
| B1/b1 | 1A | 2 | D1/d1 | 1A | 4 |
| B2/b2 | 1B | 2 | D2/d2 | 1B | 4 |
| B3/b3 | 2A | 2 | D3/d3 | 2A | 4 |
| B4/b4 | 2B | 2 | D4/d4 | 2B | 4 |
| B5/b5 | 3A | 2 | D5/d5 | 3A | 4 |
| B6/b6 | 3B | 2 | D6/d6 | 3B | 4 |
| B7/b7 | 4A | 2 | D7/d7 | 4A | 4 |
| B8/b8 | 4B | 2 | D8/d8 | 4B | 4 |

EDID Management Modes

Use the ASCII commands below to change the EDID modes. For a description of each mode please see page10.

| ASCII | EDID Mode | ASCII | EDID Mode |
|-------|-----------|-------|-----------|
| m0 | 0 | m5 | 5 |
| m1 | 1 | m6 | 6 |
| m2 | 2 | m7 | 7 |
| m3 | 3 | m8 | 8 |
| m4 | 4 | mA | A |

IR Remote Channel Configuration

All DIP switches inside the unit must be in their default OFF position. Use the ASCII commands below to change the IR code channel. Please ensure that the IR remote channel on the RMT-16IR matches any channel that is set by these commands. For a description of the IR code channel configuration please see page 9.

| ASCII | Remote Channel |
|-------|----------------|
| r1 | 1 |
| r2 | 2 |
| r3 | 3 |
| r4 | 4 |

SPECIFICATIONS

| | |
|---------------------------------|-------------------------------|
| Video Amplifier Bandwidth | 165 MHz |
| Input Video Signal | 1.2 Volts p-p |
| Input DDC Signal | 5 Volts p-p (TTL) |
| Single Link Range | 1080p/1920 x 1200 |
| HDMI Connector | Type A 19 Pin Female |
| RemoteControlPort..... | RS-232Female,3.5mmMini-Stereo |
| Power Supply | 24V DC |
| Power Consumption | 60 Watts (max) |
| Dimensions | 17.1"W x 1.7"H x 6.5"D |
| Shipping Weight | 9 lbs. |

WARRANTY

Gefen warrants the equipment it manufactures to be free from defects in material and workmanship.

If equipment fails because of such defects and Gefen is notified within two (2) years from the date of shipment, Gefen will, at its option, repair or replace the equipment, provided that the equipment has not been subjected to mechanical, electrical, or other abuse or modifications. Equipment that fails under conditions other than those covered will be repaired at the current price of parts and labor in effect at the time of repair. Such repairs are warranted for ninety (90) days from the day of reshipment to the Buyer.

This warranty is in lieu of all other warranties expressed or implied, including without limitation, any implied warranty or merchantability or fitness for any particular purpose, all of which are expressly disclaimed.

1. Proof of sale may be required in order to claim warranty.
2. Customers outside the US are responsible for shipping charges to and from Gefen.
3. Copper cables are limited to a 30 day warranty and cables must be in their original condition.

The information in this manual has been carefully checked and is believed to be accurate. However, Gefen assumes no responsibility for any inaccuracies that may be contained in this manual. In no event will Gefen be liable for direct, indirect, special, incidental, or consequential damages resulting from any defect or omission in this manual, even if advised of the possibility of such damages. The technical information contained herein regarding the features and specifications is subject to change without notice.

For the latest warranty coverage information, please visit Gefen's Warranty web page at <http://www.gefen.com/kvm/aboutus/warranty.jsp>

PRODUCT REGISTRATION

Please register your product online by visiting Gefen's web site at <http://www.gefen.com/kvm/Registry/Registration.jsp>



20600 Nordhoff St., Chatsworth CA 91311

1-800-545-6900 818-772-9100 fax: 818-772-9120

www.gefen.com support@gefen.com



Free Manuals Download Website

<http://myh66.com>

<http://usermanuals.us>

<http://www.somanuals.com>

<http://www.4manuals.cc>

<http://www.manual-lib.com>

<http://www.404manual.com>

<http://www.luxmanual.com>

<http://aubethermostatmanual.com>

Golf course search by state

<http://golfingnear.com>

Email search by domain

<http://emailbydomain.com>

Auto manuals search

<http://auto.somanuals.com>

TV manuals search

<http://tv.somanuals.com>