

Dosing Pumps

332339B
EN

To pressurize and proportion fluid in a ProMix® PD2K Electronic Positive Displacement Proportioning System.

For professional use only.



Important Safety Instructions

Read all warnings and instructions in this manual and in your PD2K proportioner manual. **Save these instructions.**

See page 2 for model part numbers and information.

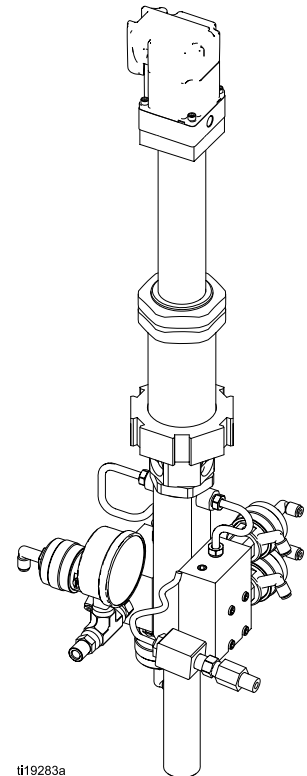

PROVEN QUALITY. LEADING TECHNOLOGY.

Contents

Models.....	2	Reconnect the Lower to the Driver	16
Warnings	3	Parts.....	17
Setup.....	5	Pump Assembly.....	17
Pump Components	5	Lower Pump Assembly.....	18
Air Connections	6	Pump Driver Assembly.....	20
Fluid Connections	8	Repair Kits, Related Manuals, and	
Electrical Connection.....	8	Accessories	21
Repair.....	9	Dimensions	22
Preventive Maintenance Schedule	9	Technical Data	23
Disconnect the Lower from the Driver	9	Graco Standard Warranty.....	24
Driver Repair	10		
Lower Repair	12		

Models

Pump Part No.	Series	Description (see NOTE below)	Maximum Fluid Working Pressure, psi (MPa, bar)
24T788	A	35cc low pressure pump	300 (2.1, 21)
24T789	A	35cc high pressure pump	1500 (10.5, 105)
24T790	A	70cc low pressure pump	300 (2.1, 21)
24T791	A	70cc high pressure pump	1500 (10.5, 105)

NOTE: Lower pumps marked with a **3** on the bottom right of the identification label are 35cc displacement pumps. Lower pumps marked with a **7** on the bottom right of the identification label are 70cc displacement pumps.



Figure 1 35cc Pump Identification Label

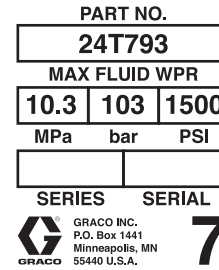

















Figure 2 70cc Pump Identification Label

Warnings

The following warnings are for the setup, use, grounding, maintenance and repair of this equipment. The exclamation point symbol alerts you to a general warning and the hazard symbol refers to procedure-specific risks. When these symbols appear in the body of this manual or on warning labels, refer back to these Warnings. Product-specific hazard symbols and warnings not covered in this section may appear throughout the body of this manual where applicable.

 <h2 style="margin: 0;">WARNING</h2>	
   	<p>FIRE AND EXPLOSION HAZARD</p> <p>Flammable fumes, such as solvent and paint fumes, in work area can ignite or explode. To help prevent fire and explosion:</p> <ul style="list-style-type: none"> • Use equipment only in well ventilated area. • Eliminate all ignition sources; such as pilot lights, cigarettes, portable electric lamps, and plastic drop cloths (potential static arc). • Keep work area free of debris, including solvent, rags and gasoline. • Do not plug or unplug power cords, or turn power or light switches on or off when flammable fumes are present. • Ground all equipment in the work area. See Grounding instructions. • Use only grounded hoses. • Hold gun firmly to side of grounded pail when triggering into pail. Do not use pail liners unless they are antistatic or conductive. • Stop operation immediately if static sparking occurs or you feel a shock, Do not use equipment until you identify and correct the problem. • Keep a working fire extinguisher in the work area.
  	<p>SKIN INJECTION HAZARD</p> <p>High-pressure fluid from gun, hose leaks, or ruptured components will pierce skin. This may look like just a cut, but it is a serious injury that can result in amputation. Get immediate surgical treatment.</p> <ul style="list-style-type: none"> • Do not spray without tip guard and trigger guard installed. • Engage trigger lock when not spraying. • Do not point gun at anyone or at any part of the body. • Do not put your hand over the spray tip. • Do not stop or deflect leaks with your hand, body, glove, or rag. • Follow the Pressure Relief Procedure when you stop spraying/dispersing and before cleaning, checking, or servicing equipment. • Tighten all fluid connections before operating the equipment. • Check hoses, tubes, and couplings daily. Replace worn or damaged parts immediately.

 <h1 style="margin: 0;">WARNING</h1>	
 	<p>MOVING PARTS HAZARD Moving parts can pinch, cut or amputate fingers and other body parts.</p> <ul style="list-style-type: none"> • Keep clear of moving parts. • Do not operate equipment with protective guards or covers removed. • Pressurized equipment can start without warning. Before checking, moving, or servicing equipment, follow the Pressure Relief Procedure and disconnect all power sources.
 	<p>TOXIC FLUID OR FUMES Toxic fluids or fumes can cause serious injury or death if splashed in the eyes or on skin, inhaled, or swallowed.</p> <ul style="list-style-type: none"> • Read MSDSs to know the specific hazards of the fluids you are using. • Store hazardous fluid in approved containers, and dispose of it according to applicable guidelines. • Always wear chemically impermeable gloves when spraying, dispensing, or cleaning equipment.
	<p>PERSONAL PROTECTIVE EQUIPMENT Wear appropriate protective equipment when in the work area to help prevent serious injury, including eye injury, hearing loss, inhalation of toxic fumes, and burns. This protective equipment includes but is not limited to:</p> <ul style="list-style-type: none"> • Protective eyewear, and hearing protection. • Respirators, protective clothing, and gloves as recommended by the fluid and solvent manufacturer.
 	<p>EQUIPMENT MISUSE HAZARD Misuse can cause death or serious injury.</p> <ul style="list-style-type: none"> • Do not operate the unit when fatigued or under the influence of drugs or alcohol. • Do not exceed the maximum working pressure or temperature rating of the lowest rated system component. See Technical Data in all equipment manuals. • Use fluids and solvents that are compatible with equipment wetted parts. See Technical Data in all equipment manuals. Read fluid and solvent manufacturer's warnings. For complete information about your material, request MSDS from distributor or retailer. • Do not leave the work area while equipment is energized or under pressure. • Turn off all equipment and follow the Pressure Relief Procedure when equipment is not in use. • Check equipment daily. Repair or replace worn or damaged parts immediately with genuine manufacturer's replacement parts only. • Do not alter or modify equipment. Alterations or modifications may void agency approvals and create safety hazards. • Make sure all equipment is rated and approved for the environment in which you are using it. • Use equipment only for its intended purpose. Call your distributor for information. • Route hoses and cables away from traffic areas, sharp edges, moving parts, and hot surfaces. • Do not kink or over bend hoses or use hoses to pull equipment. • Keep children and animals away from work area. • Comply with all applicable safety regulations.

Setup

Pump Components

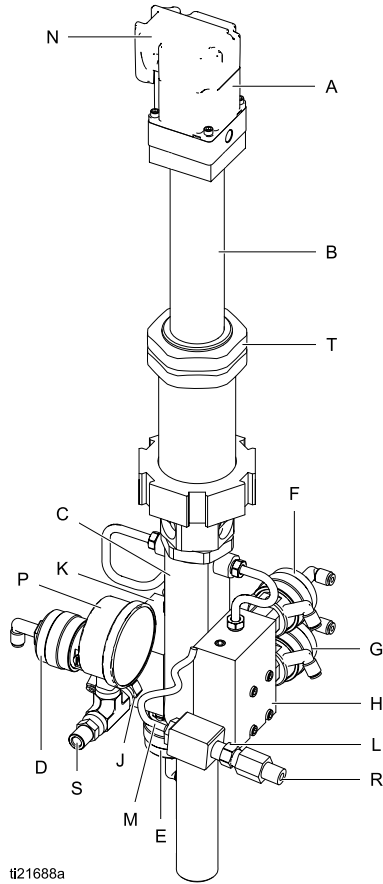

fi21688a

Figure 3 Pump Components

Component	Description
A	Stepper Motor
B	Driver
C	Pump Lower
D	Up Inlet Dose Valve
E	Down Inlet Dose Valve
F	Up Outlet Dose Valve
G	Down Outlet Dose Valve
H	Fluid Outlet Manifold
J	Fluid Inlet Check Valve
K	Fluid Inlet Manifold
L	Fluid Outlet Check Valve
M	Fluid Outlet Pressure Sensor
N	Cable Connection to Pump Control Module
P	Fluid Inlet Pressure Gauge
R	Fluid Outlet Fitting (1/4 npt(m))
S	Fluid Inlet Fitting (1/4 npt(m))
T	Jam Nuts, for mounting pump

Air Connections

Red and green 5/32 in. (4 mm) tubing connects the solenoid manifold to the pump's dosing valves. See the Pump Tubing Schematic on the next page.

NOTE: Tubing lengths must be 18 in. \pm 1/2 in. (457 mm \pm 13 mm) for all connections. Always use equal lengths of tubing, to balance the timing of the valves. Lengths longer than 18 in. (457 mm) will increase valve response time.

1. On the bottom of the solenoid manifold are four ports with tube fittings: UP OPEN, UP CLOSED, DOWN OPEN, and DOWN CLOSED. These ports provide air to open and close the pump's inlet dosing valves.

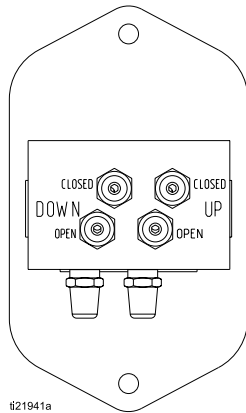

Figure 4 Tubing Connections at Solenoid Manifold, to Pump Inlet Manifold

- a. Connect green tubing (G) from the UP OPEN fitting to the 90° tube fitting on the side of the INLET UP dosing valve.
- b. Connect red tubing (R) from the UP CLOSED fitting to the 90° tube fitting on the end of the INLET UP dosing valve.
- c. Connect green tubing (G) from the DOWN OPEN fitting to the 90° tube fitting on the side of the INLET DOWN dosing valve.
- d. Connect red tubing (R) from the DOWN CLOSED fitting to the 90° tube fitting on the end of the INLET DOWN dosing valve.

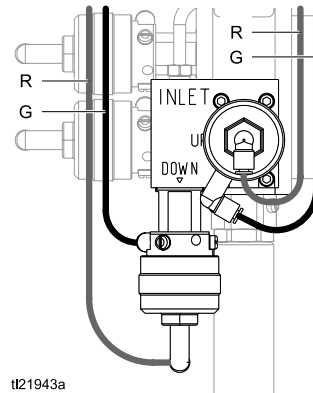

Figure 5 Inlet Manifold Tubing Connections

2. On the side of the solenoid manifold are four ports with 90° tube fittings (not shown): UP OPEN, UP CLOSED, DOWN OPEN, and DOWN CLOSED. These ports provide air to open and close the pump's outlet dosing valves.

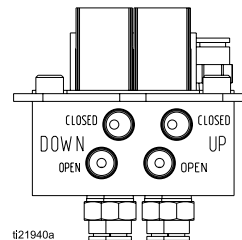

Figure 6 Tubing Connections at Solenoid Manifold, to Pump Outlet Manifold

- a. Connect green tubing (G) from the UP OPEN fitting to the 90° tube fitting on the side of the OUTLET UP dosing valve.
- b. Connect red tubing (R) from the UP CLOSED fitting to the 90° tube fitting on the end of the OUTLET UP dosing valve.

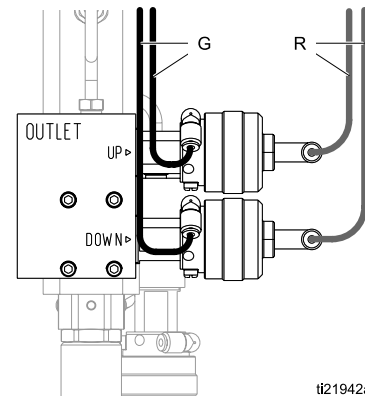

Figure 7 Outlet Manifold Tubing Connections

- c. Connect green tubing (G) from the DOWN OPEN fitting to the 90° tube fitting on the side of the OUTLET DOWN dosing valve.
 - d. Connect red tubing (R) from the DOWN CLOSED fitting to the 90° tube fitting on the end of the OUTLET DOWN dosing valve.
3. Repeat these steps for each pump in your system.

See the following table to understand the relationship between pump stroke and dose valve actuation.

Table 1 Dose Valve Actuation

Pump Stroke	Up Inlet Valve	Down Inlet Valve	Up Outlet Valve	Down Outlet Valve
Up	Open	Closed	Open	Closed
Down	Closed	Open	Closed	Open

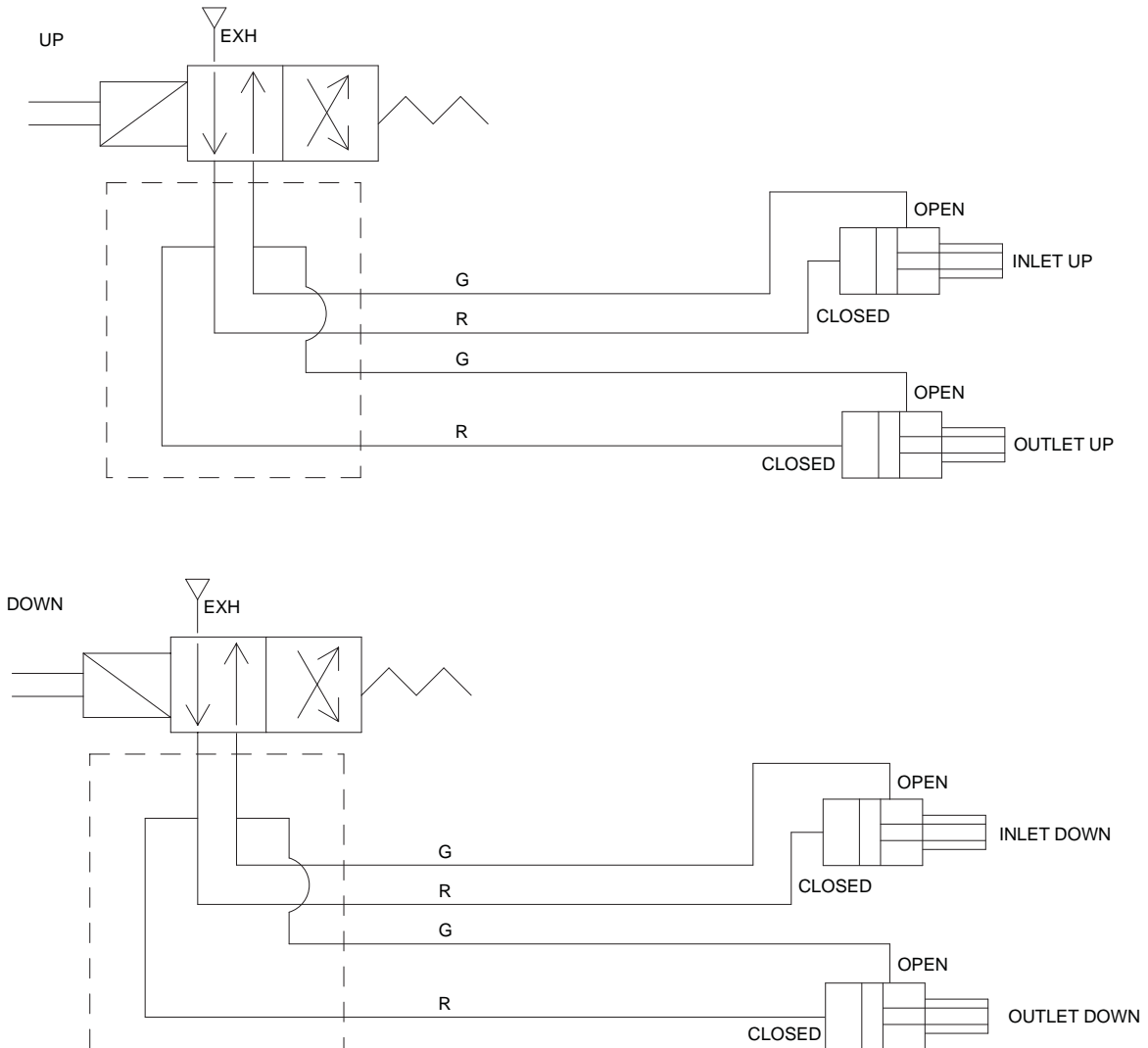
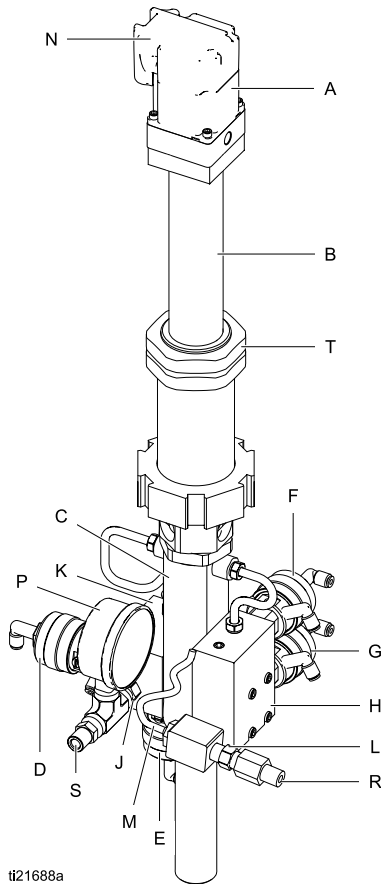

Figure 8 Pump Tubing Schematic

Fluid Connections

1. Connect a 1/4 npt(f) fluid hose from the fluid source to the check valve (J) at the pump's fluid inlet manifold (K). The inlet dose valves (D, E) will open and close alternately at the pump stroke changeover, to maintain a steady flow into the pump.
2. Connect a 1/4 npt(f) fluid outlet hose from the check valve (L) at the pump's fluid outlet manifold (H). The outlet dose valves (F, G) will open and close alternately at the pump stroke changeover, to maintain a steady flow out of the pump.



tt21688a

Figure 9 Fluid Connections

Electrical Connection

NOTICE

To avoid electrical component damage, remove all system power before plugging any connectors.

Connect the cable from the pump control module in the proportioner's electrical control box to the cable connector (N) on the pump motor (A).





The cable has two connectors, one for the motor control and the other for encoder feedback. The connectors are keyed differently to ensure correct installation.

Repair

Preventive Maintenance Schedule

The operating conditions of your particular system determine how often maintenance is required. Establish a preventive maintenance schedule by recording when and what kind of maintenance is needed, and then determine a regular schedule for checking your system.

Disconnect the Lower from the Driver

				
<p>This equipment stays pressurized until pressure is manually relieved. To help prevent serious injury from pressurized fluid such as skin injection, splashing fluid, and moving parts, follow the Pressure Relief Procedure in your system manual when you stop spraying and before cleaning, checking, or servicing the equipment.</p>				

1. Follow the **Pressure Relief Procedure** in your proportioner manual. Stop the pump at the bottom of its stroke.
2. Remove the pump from the proportioner, as explained in your proportioner manual.
3. Remove the TSL inlet fitting (17) and set aside.
4. Unscrew the connecting nut (207).
5. Move the o-ring (106) down onto the pump piston rod (2) to allow access to the pin (103). Remove the pin.

NOTE: If you are only repairing the piston rod (2) and its packings, it is not necessary to completely remove the lower from the driver. After removing the pin (103), go to **Disassemble the Lower**, page 12 and push the rod down out of the cylinder. Disassemble the piston rod as explained there.

6. Disconnect all air and fluid lines from the dosing valves and manifolds. Be sure to label the lines to ensure they are re-connected correctly.
7. Pull the lower away from the driver.
 - a. To service the driver, see **Driver Repair**, page 10.
 - b. To service the lower, see **Lower Repair**, page 12.

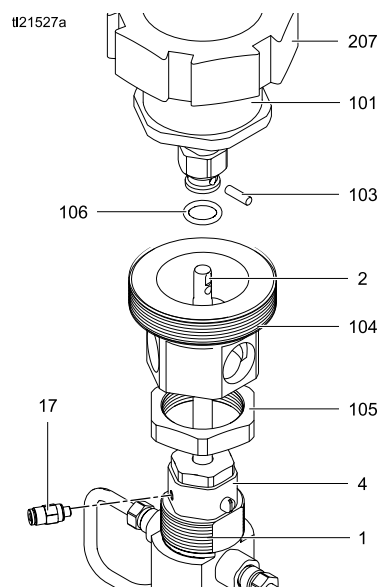

Figure 10 Disconnect the Lower from the Driver

Driver Repair

Disassemble the Driver

1. See Disconnect the Lower from the Driver, page 9 .
2. Remove the four screws (201e) and remove the motor (202) from the actuator (201). The motor-side coupler (201a) and insert (201b) will come off with the motor.
3. Pull the actuator (201) out the top of the housing (203). Do not remove the actuator-side coupler from the recess at the top of the actuator. The guide (205) and coupling nut (204) should only be removed if they are damaged or you are replacing the actuator.

Reassemble the Driver

1. If the guide (205) and coupling nut (204) were removed, apply primer and thread adhesive to the bottom threads of the actuator (201). Install the guide and coupling nut. Torque the coupling nut to 15–25 ft-lb (20–34 N•m). Allow 12 hours for the adhesive to cure.
2. Apply thread adhesive to the threads on the actuator sleeve. Insert the actuator (201) into the housing (203) so the tabs of the guide (205) slide in the groove in the housing. Screw the actuator into the housing.

NOTICE

To prevent possible damage to the motor, the motor-side coupler (201a) surface must be flush with the end of the motor shaft.

3. Check that the motor-side coupler (201a) surface is flush with the end of the motor shaft. Torque the two screws (201c) to 35–45 in-lb (4–5 N•m).
4. Ensure that the coupler insert (201b) is in place. Mount the motor (202) onto the actuator so the two couplers engage. Inspect the motor-to-actuator fit; the motor **must** rest flat on the actuator housing.

NOTICE

If the motor does not rest flat on the actuator housing, determine the cause and correct before installing the screws (201d). An incorrect fit will create a thrust load on the motor shaft, which will cause motor failure if operated.

5. Install the four screws (201d).
6. See Reconnect the Lower to the Driver, page 16.

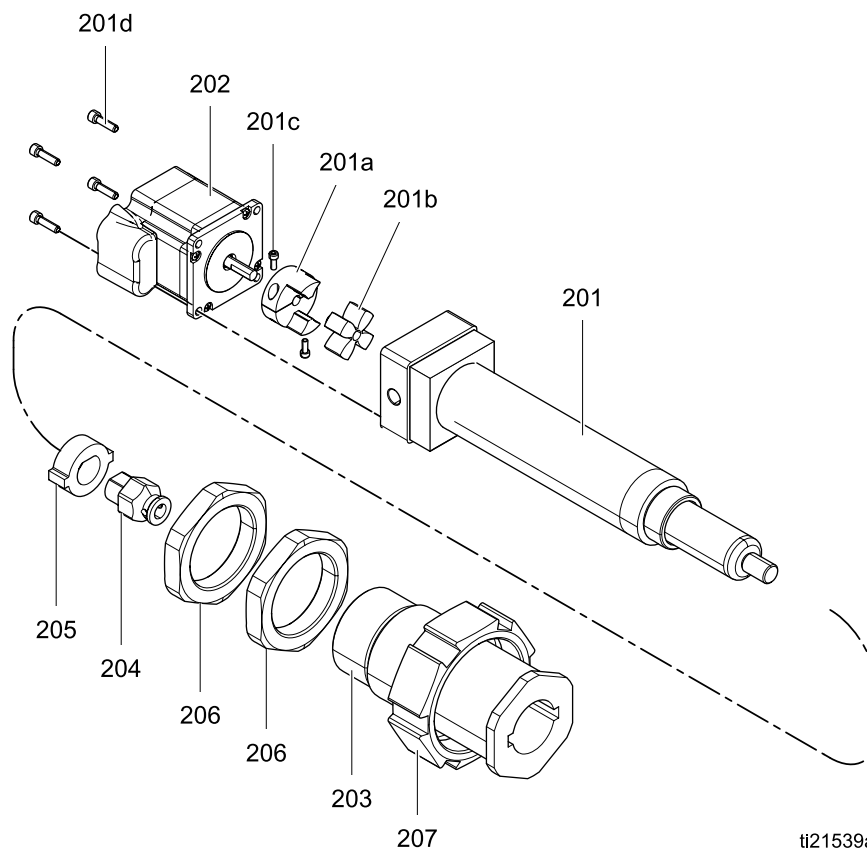

Figure 11 Driver Assembly

ti21539a

Lower Repair

Disassemble the Lower

1. Remove the lower from the driver; see Disconnect the Lower from the Driver, page 9 .
2. Remove the top and bottom throat cartridges (4) to expose the piston rod (2a/2b).
3. Push the piston rod assembly down out the bottom of the cylinder (1).
4. Disassemble the piston rod (2a, 2b), using the flats on both ends. Remove the piston parts (12–16, 42) from the lower rod (2b).
5. Unscrew the upper packing nut (5) from the upper throat cartridge (4). Remove the o-rings (7), packings (10), and bearing (11).
6. Remove the rod guard (8). Unscrew the lower packing nut (6) from the lower throat cartridge (4). Remove the o-rings (7), packings (10), and bearing (11).
7. Unscrew the dosing valves (25) from the manifolds (19 and 20). Remove the seats (23) and o-rings (22, 24).
8. Disconnect the inlet (29) and outlet (28) tubes at the cylinder (1). Remove the adapters (27) and o-rings (33).
9. Remove the screws (26) holding the manifolds (19, 20) to the cylinder (1). Remove the o-rings (21).
10. Clean and inspect all parts.

NOTE: The 70 cc lower 24T793 includes two u-cups (10) in the lower throat cartridge; the 35 cc lower 24T792 includes one.

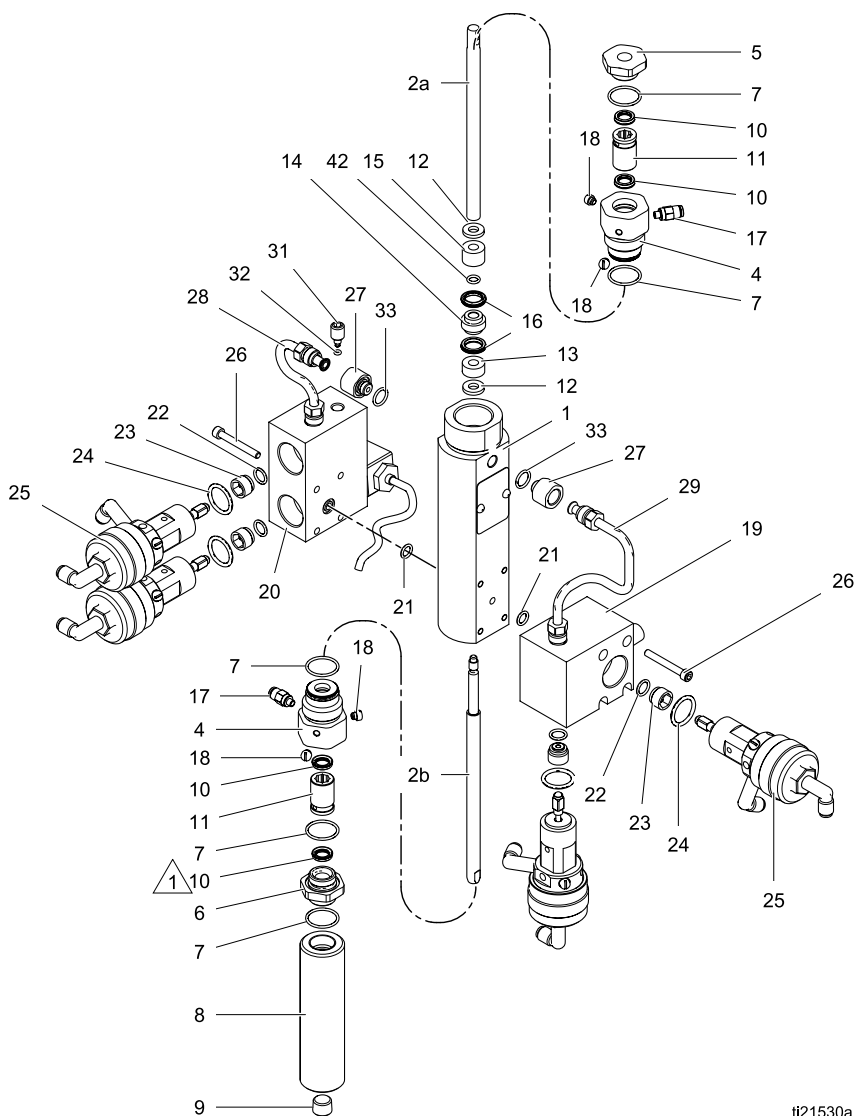

Figure 12 Lower Pump Assembly

ti21530a

Reassemble the Lower

1. Install the manifolds (19, 20) on the cylinder (1). Lubricate the o-rings (21) and ensure they are in place on the mating surfaces. Apply thread adhesive to the screws (26) and torque to 13–23 in-lb (1.5–2.5 N•m).
2. Lubricate the o-rings (33). Apply thread lubricant and install the adapters (27) and o-rings (33) on the cylinder (1). Connect the inlet (29) and outlet (28) tubes at the cylinder (1).
3. Lubricate the o-rings (22, 24). Install the o-rings (22), seats (23), and o-rings (24) in the manifolds (19 and 20). Apply thread lubricant and screw the dosing valves (25) into the manifolds. Torque to 20–30 ft-lb (28–40 N•m).
4. Lubricate the piston packings (16) and o-ring (42). Assemble the piston on the lower rod (2b) as follows:
 - a. Install one washer (12) and the bottom (shorter) spacer (13).
 - b. Install one packing (16) on each shoulder of the piston bearing (14), with the lips facing away from the bearing. Install the piston bearing (14).
 - c. Install the o-ring (42), the top (longer) spacer (15), and one washer (12).

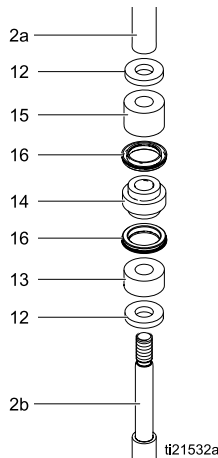

Figure 13 Piston Rod Assembly

5. Apply thread adhesive to the male threads of the lower rod (2b). Screw the upper piston rod (2a) onto the lower rod, using the flats on both ends. Torque to 35–45 ft-lb (48–61 N•m).
6. Insert the piston rod assembly into the cylinder (1) from the bottom. Push the rod up until it protrudes from the top of the cylinder (1).

NOTE: The 70 cc lower 24T793 includes two u-cup packings (10) in the lower throat cartridge; the 35 cc lower 24T792 includes only the upper one.
7. Lubricate the o-rings (7) and packing(s) (10). Place the upper packing (10) into the tool (T) included with the seal kit. The lips of the packing must face out of the tool. Insert the tool into the lower throat cartridge (4). Push on the tool's shaft (P) to seat the packing securely in the cartridge. When seated, the lips of the packing will be facing up. Install the bearing (11). On 70 cc lowers only, install the second packing (10) with the lips also facing up.

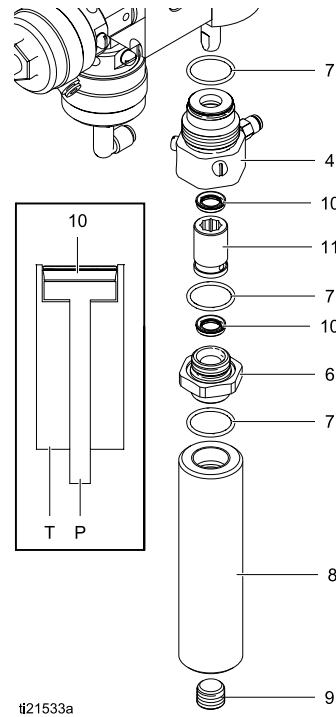

Figure 14 Lower Throat Assembly

8. Install the o-rings (7) on the lower packing nut (6). Screw the packing nut into the lower throat cartridge (4). Torque to 20–30 ft-lb (28–40 N•m).
9. Slide the lower packing cartridge (4) onto the piston rod (2) and screw the cartridge into the cylinder (1). Torque to 35–45 ft-lb (48–61 N•m).
10. Screw the rod guard (8) securely onto the lower packing nut (6). Make sure the plug (9) is in place at the bottom of the rod guard.
11. Lubricate the o-rings (7) and packing(s) (10). Place one packing (10) into the tool (T) included with the seal kit. The lips of the packing must face out of the tool. Insert the tool into the upper throat cartridge (4). Push on the tool's shaft (P) to seat the packing securely in the cartridge. When seated, the lips of the packing will be facing down. Install the bearing (11). Install the second packing (10) with the lips facing down.
12. Install the o-ring (7) on the upper packing nut (5). Screw the packing nut into the upper throat cartridge (4). Torque to 20–30 ft-lb (28–40 N•m).
13. Slide the upper packing cartridge (4) onto the piston rod (2) and screw the cartridge into the cylinder (1). Torque to 35–45 ft-lb (48–61 N•m).
14. Install the lower on the driver; see Reconnect the Lower to the Driver, page 16.

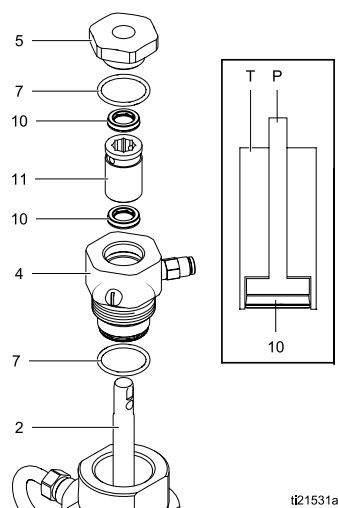

Figure 15 Upper Throat Assembly

Reconnect the Lower to the Driver

1. Ensure that the air fitting (17) is removed and set aside.
2. Screw the jam nut (105) and connector (104) onto the pump cylinder (1), all the way to the bottom of the threads.
3. Align the holes in the connector (104) with the ports in the throat cartridge (4).
4. Torque the jam nut (105) to 65–75 ft-lb (88–101 N•m).
5. Reinstall the TSL inlet fitting (17) in the open port.
6. Place the o-ring (106) on the piston rod (2).
7. Align the holes in the motor shaft and piston rod. Install the pin (103).
8. Slide the o-ring (106) up off the piston rod and into the groove on the motor shaft, covering the pin.
9. Screw the connecting nut (207) onto the connector (104). Torque to 45–55 ft-lb (61–74 N•m).
10. Reinstall the pump on the proportioner, as explained in your proportioner manual.

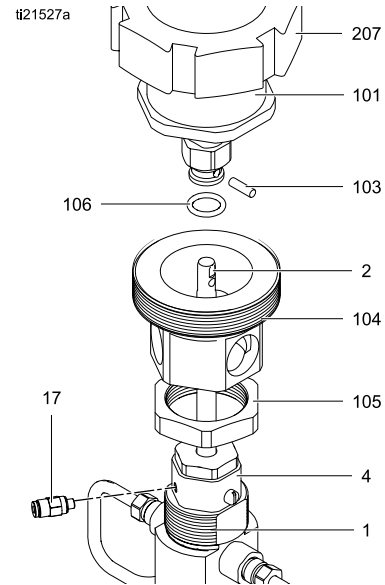

Figure 16 Reconnect the Lower to the Driver

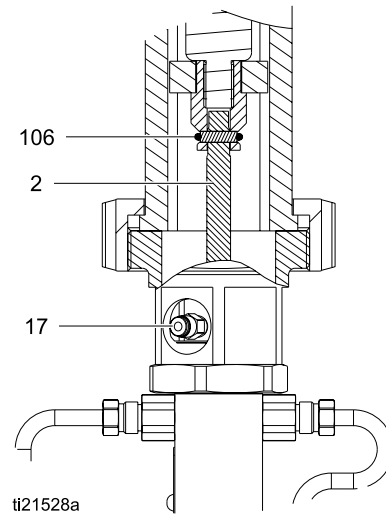
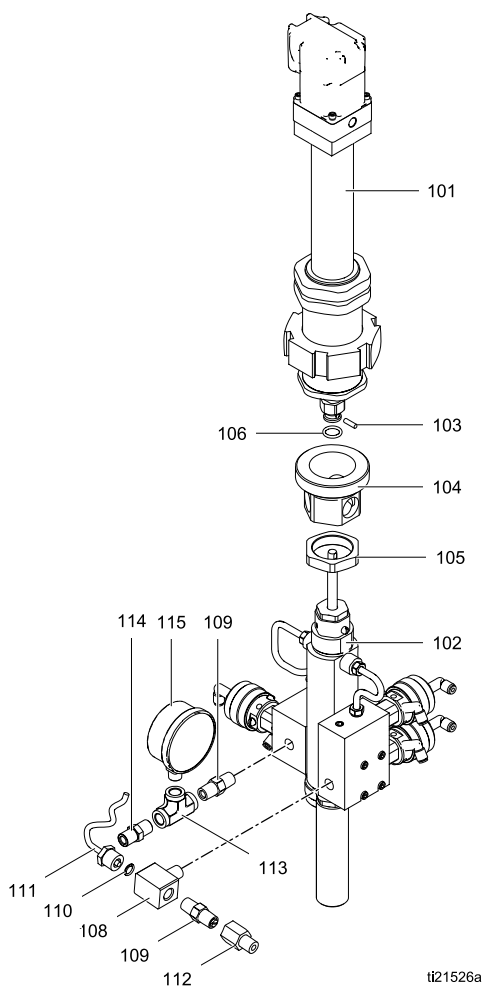

Figure 17 Orient the Lower to the Driver

Parts

Pump Assembly

24T788, Series A, 35 cc Low Pressure Pump
 24T789, Series A, 35 cc High Pressure Pump
 24T790, Series A, 70 cc Low Pressure Pump
 24T791, Series A, 70 cc High Pressure Pump



Ref	Part	Description	Qty
101	24T794	DRIVER, low pressure; Models 24T788 and 24T790; see Pump Driver Assembly, page 20	1
	24T795	DRIVER, high pressure; Models 24T789 and 24T791; see Pump Driver Assembly, page 20	1
102	24T792	LOWER, pump, 35 cc; Models 24T788 and 24T789; see Lower Pump Assembly, page 18	1
	24T793	LOWER, pump, 70 cc; Models 24T790 and 24T791; see Lower Pump Assembly, page 18	1
103	16N762	PIN, coupler	1
104	16N744	CONNECTOR	1
105	16N748	NUT, jam	1
106	115485	O-RING	1
108	16F164	FITTING, sensor, pressure	1
109	24T310	VALVE, check	2
110	121399	O-RING; chemically resistant	1
111	24T786	SENSOR, fluid outlet pressure (24T788 and 24T790)	1
	24T809	SENSOR, fluid outlet pressure (24T789 and 24T791)	1
112	119226	ADAPTER; 1/4 npt (m x f); sst	1
113	104984	TEE; 1/4 npt (f)	1
114	166421	NIPPLE; 1/4 npt	1
115	187876	GAUGE, pressure, fluid (24T788 and 24T790)	1
	112941	GAUGE, pressure, fluid (24T789 and 24T791)	1

24T792, Series A, 35 cc Lower
24T793, Series A, 70 cc Lower

Ref	Part	Description	Qty	Ref	Part	Description	Qty
1	24U604	CYLINDER, 35 cc; Model 24T792	1		†	For Model 24T793	1
	24U605	CYLINDER, 70 cc; Model 24T793	1	16	- — —	PACKING, piston, u-cup; UHMWPE	
2	24T842	KIT, piston rod assembly; includes items 2a and 2b	1		*	For Model 24T792	2
2a	— — —	ROD, piston, upper	1		†	For Model 24T793	2
2b	— — —	ROD, piston, lower	1	17	111328	CONNECTOR, male; 10–32 x 5/32 in. (4 mm) OD tube	2
4	16N750	FITTING, throat cartridge	2	18	104644	PLUG, screw; 10–32	4
5	16N751	NUT, packing, upper	1	19	24T810	MANIFOLD, inlet; includes items 22 and 23	1
6	16T350	NUT, packing, lower	1	20	24T811	MANIFOLD, outlet; includes items 22 and 23	1
7	* †	O-RING; ptfe	5	21	* †	O-RING; ptfe	2
8	16T352	GUARD, rod; Model 24T792	1	22	* † ♦	O-RING; ptfe	4
	16T351	GUARD, rod; Model 24T793	1	23	♦	RETAINER, seat, valve	4
9	100361	PLUG, pipe; 1/2 npt	1	24	* † ♦	O-RING; ptfe	4
10	— — —	PACKING, throat, u-cup; UHMWPE; For Model 24T792	3	25	15X303	VALVE, dispense; see manual 312782	4
	†	For Model 24T793	4	26	104472	SCREW, cap, socket head; 10–32 x 1.5 in. (38 mm)	8
11	* †	BEARING, throat	2	27	‡	ADAPTER, pump	2
12	* †	WASHER, piston	2	28	‡	TUBE, outlet	1
13	- — —	SPACER, piston, bottom		29	‡	TUBE, inlet	1
	*	For Model 24T792	1	31	- — —	PLUG, pump	1
	†	For Model 24T793	1	32	* †	O-RING; ptfe	1
14	- — —	BEARING, piston		33	* †‡	O-RING; ptfe	2
	*	For Model 24T792	1	42	* †	O-RING; chemically resistant	1
	†	For Model 24T793	1				
15	- — —	SPACER, piston, top					
	*	For Model 24T792	1				

Items marked — — — are not available separately.

* Included in 35 cc Lower Seal Repair Kit 24T895, which must be purchased separately.

† Included in 70 cc Lower Seal Repair Kit 24T896, which must be purchased separately.

♦ Included in Dosing Valve Seat Replacement Kit 24T843, which must be purchased separately.

‡ Included in Tube Assembly Kit 24T822, which must be purchased separately.

Pump Driver Assembly

24T794, Series A, Low Pressure Pump Driver
 24T795, Series A, High Pressure Pump Driver

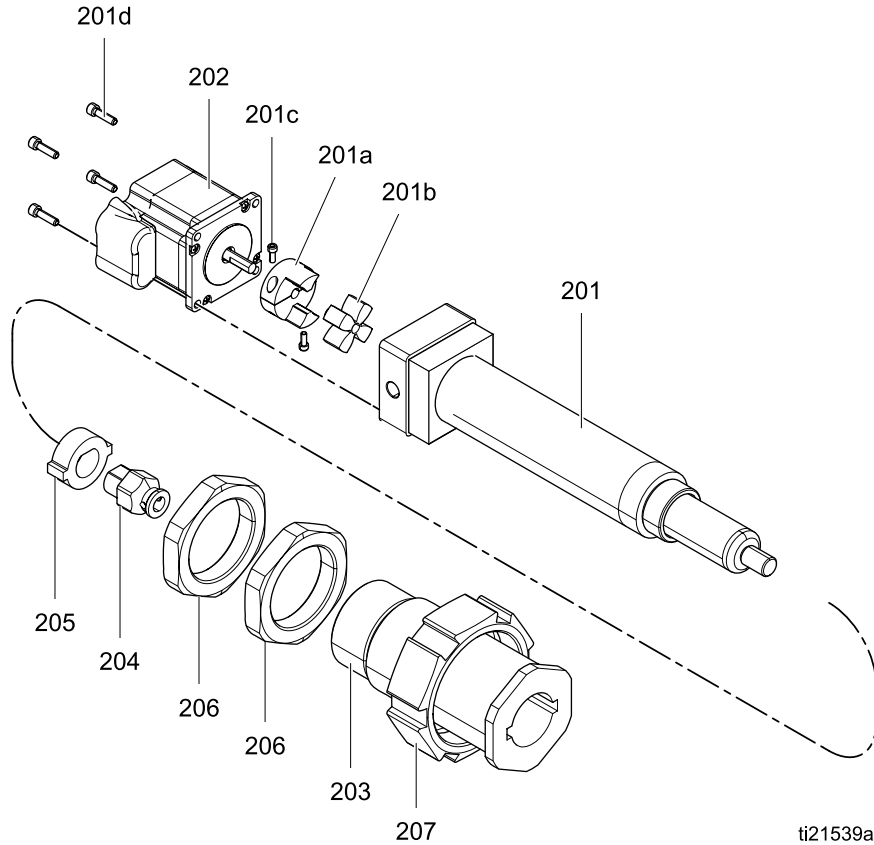

ti21539a

Ref	Part	Description	Qty	Ref	Part	Description	Qty
201	16N742	ACTUATOR, linear; for 24T794	1	16N781	HOUSING, actuator; for 24T795	1	
	16N777	ACTUATOR, linear; for 24T795	1	204	16N758	NUT, coupling; for 24T794	1
201a	---	COUPLER	1	16N785	NUT, coupling; for 24T795	1	
201b	---	INSERT, coupler	1	205	16N764	GUIDE, rod; for 24T794	1
201c	---	SCREW, coupler	2	16N783	GUIDE, rod; for 24T795	1	
201d	---	SCREW, motor mounting	4	206	16N835	NUT, jam	2
202	16P037	MOTOR, stepper, 23 frame; for 24T794	1	207	16N745	NUT, connecting	1
	16P036	MOTOR, stepper, 34 frame; for 24T795	1				
203	16N743	HOUSING, actuator; for 24T794	1				

Items marked --- are not available separately.

Repair Kits, Related Manuals, and Accessories

Description	Kit Part No.	Kit Description
All pumps in this manual.	24T843	Dosing Valve Seat Replacement Kit. Includes seats and o-rings for all four dosing valves on a pump.
	24T302	TSL Cup Kit
	24T303	Throat Seal Installation Tool. Also included in Seal Kits 24T840 and 24T841.
Model 24T792 35 cc Lower	24T840	Pump Seal Repair Kit. Includes 24T303 Throat Seal Installation Tool.
Model 24T793 70 cc Lower	24T841	Pump Seal Repair Kit. Includes 24T303 Throat Seal Installation Tool.

Dimensions

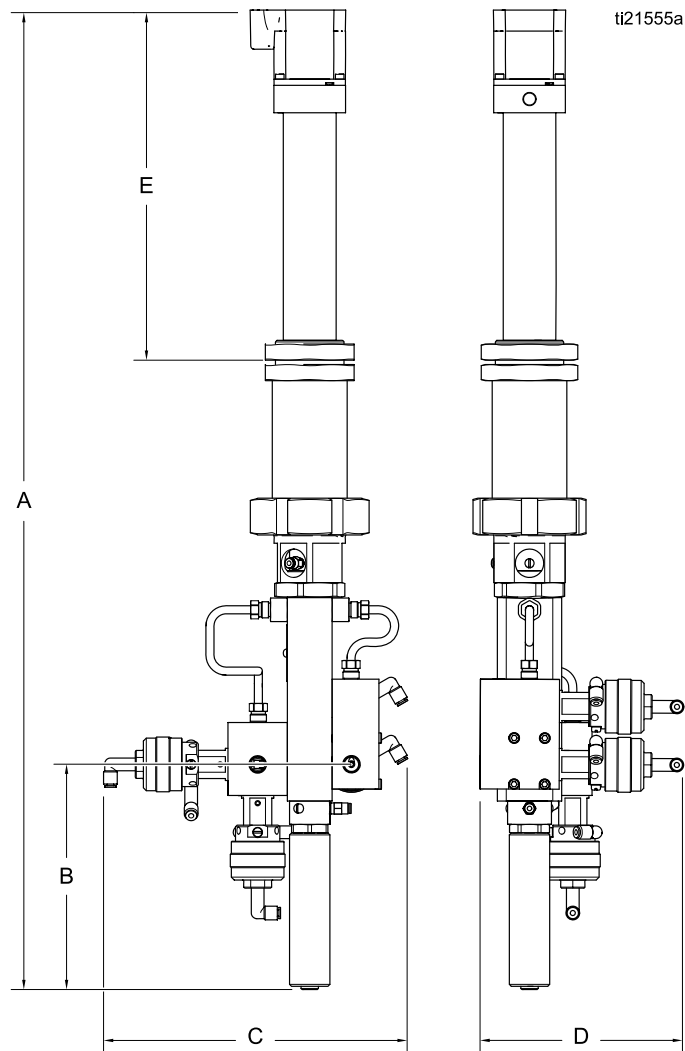

Pump Model	A, in. (mm)	B, in. (mm)	C, in. (mm)	D, in. (mm)	E, in. (mm)
24T788, 24T789	33.0 (838)	7.375 (187)	8.25 (210)	7.50 (191)	13.375 (340)
24T790, 24T791	34.25 (870)	7.375 (187)	8.25 (210)	7.50 (191)	14.50 (368)

Technical Data

Dosing Pumps	U.S.	Metric
Maximum fluid working pressure:		
24T788 and 24T790	300 psi	2.1 MPa, 21 bar
24T789 and 24T791	1500 psi	10.5 MPa, 105 bar
Maximum working air pressure:	100 psi	0.7 MPa, 7.0 bar
Air supply:	85–100 psi	0.6–0.7 MPa, 6.0–7.0 bar)
Fluids handled:	one or two component: <ul style="list-style-type: none"> • solvent and waterborne paints • polyurethanes • epoxies • acid catalyzed varnishes • moisture sensitive isocyanates 	
Viscosity range of fluid:	20–5000 centipoise	
Fluid inlet size:	1/4 npt(m)	
Fluid outlet size:	1/4 npt(m)	
Air inlet size (dosing valves):	5/32 in. OD tube	4 mm OD tube
Stepper motor	48 Vdc, 4 amp The motor includes an encoder and internal controller requiring step and direction input integration to a PD2K controller or similar control module to operate.	
Operating temperature range:	41–122°F	5–50°C
Weight:		
24T788 and 24T790	21.2 lb	9.6 kg
24T789 and 24T791	23.5 lb	10.7 kg
Sound data:	Less than 75 dB(A)	
Wetted parts:	17–4PH, 303, 304 SST, Tungsten carbide (with nickel binder), perfluoroelastomer; PTFE, PPS, UHMWPE	

Graco Standard Warranty

Graco warrants all equipment referenced in this document which is manufactured by Graco and bearing its name to be free from defects in material and workmanship on the date of sale to the original purchaser for use. With the exception of any special, extended, or limited warranty published by Graco, Graco will, for a period of twelve months from the date of sale, repair or replace any part of the equipment determined by Graco to be defective. This warranty applies only when the equipment is installed, operated and maintained in accordance with Graco's written recommendations.

This warranty does not cover, and Graco shall not be liable for general wear and tear, or any malfunction, damage or wear caused by faulty installation, misapplication, abrasion, corrosion, inadequate or improper maintenance, negligence, accident, tampering, or substitution of non-Graco component parts. Nor shall Graco be liable for malfunction, damage or wear caused by the incompatibility of Graco equipment with structures, accessories, equipment or materials not supplied by Graco, or the improper design, manufacture, installation, operation or maintenance of structures, accessories, equipment or materials not supplied by Graco.

This warranty is conditioned upon the prepaid return of the equipment claimed to be defective to an authorized Graco distributor for verification of the claimed defect. If the claimed defect is verified, Graco will repair or replace free of charge any defective parts. The equipment will be returned to the original purchaser transportation prepaid. If inspection of the equipment does not disclose any defect in material or workmanship, repairs will be made at a reasonable charge, which charges may include the costs of parts, labor, and transportation.

THIS WARRANTY IS EXCLUSIVE, AND IS IN LIEU OF ANY OTHER WARRANTIES, EXPRESS OR IMPLIED, INCLUDING BUT NOT LIMITED TO WARRANTY OF MERCHANTABILITY OR WARRANTY OF FITNESS FOR A PARTICULAR PURPOSE.

Graco's sole obligation and buyer's sole remedy for any breach of warranty shall be as set forth above. The buyer agrees that no other remedy (including, but not limited to, incidental or consequential damages for lost profits, lost sales, injury to person or property, or any other incidental or consequential loss) shall be available. Any action for breach of warranty must be brought within two (2) years of the date of sale.

GRACO MAKES NO WARRANTY, AND DISCLAIMS ALL IMPLIED WARRANTIES OF MERCHANTABILITY AND FITNESS FOR A PARTICULAR PURPOSE, IN CONNECTION WITH ACCESSORIES, EQUIPMENT, MATERIALS OR COMPONENTS SOLD BUT NOT MANUFACTURED BY GRACO. These items sold, but not manufactured by Graco (such as electric motors, switches, hose, etc.), are subject to the warranty, if any, of their manufacturer. Graco will provide purchaser with reasonable assistance in making any claim for breach of these warranties.

In no event will Graco be liable for indirect, incidental, special or consequential damages resulting from Graco supplying equipment hereunder, or the furnishing, performance, or use of any products or other goods sold hereto, whether due to a breach of contract, breach of warranty, the negligence of Graco, or otherwise.

FOR GRACO CANADA CUSTOMERS

The Parties acknowledge that they have required that the present document, as well as all documents, notices and legal proceedings entered into, given or instituted pursuant hereto or relating directly or indirectly hereto, be drawn up in English. Les parties reconnaissent avoir convenu que la rédaction du présent document sera en Anglais, ainsi que tous documents, avis et procédures judiciaires exécutés, donnés ou intentés, à la suite de ou en rapport, directement ou indirectement, avec les procédures concernées.

Graco Information

For the latest information about Graco products, visit www.graco.com.

To place an order, contact your Graco Distributor or call to identify the nearest distributor.

Phone: 612-623-6921 **or Toll Free:** 1-800-328-0211 **Fax:** 612-378-3505

All written and visual data contained in this document reflects the latest product information available at the time of publication.

Graco reserves the right to make changes at any time without notice.

For patent information, see www.graco.com/patents.

Original Instructions. This manual contains English. MM 332339

Graco Headquarters: Minneapolis

International Offices: Belgium, China, Japan, Korea

GRACO INC. AND SUBSIDIARIES • P.O. BOX 1441 • MINNEAPOLIS MN 55440-1441 • USA

Copyright 2013, Graco Inc. All Graco manufacturing locations are registered to ISO 9001.

www.graco.com

Revised October 2013

Free Manuals Download Website

<http://myh66.com>

<http://usermanuals.us>

<http://www.somanuals.com>

<http://www.4manuals.cc>

<http://www.manual-lib.com>

<http://www.404manual.com>

<http://www.luxmanual.com>

<http://aubethermostatmanual.com>

Golf course search by state

<http://golfingnear.com>

Email search by domain

<http://emailbydomain.com>

Auto manuals search

<http://auto.somanuals.com>

TV manuals search

<http://tv.somanuals.com>