

NOTE:
Please read all instructions
carefully before using this
product

Table of Contents

Safety Notice

Important Assembly
Information

Care and Maintenance

Parts List

Warranty

Ordering Parts

Model
MFM-8250

Retain This
Manual for
Reference

120802

**OWNER'S
MANUAL**

IMPEX
FITNESS PRODUCTS

**MARCY[®] FIT
DELUXE HOME GYM
MFM-8250**

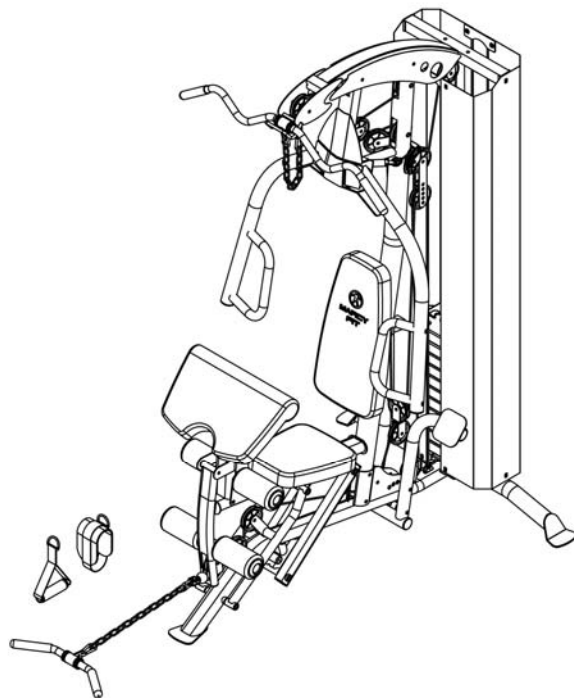

**IMPORTANT: Please read this manual before commencing
assembly of this product.**

IMPEX[®] INC.

2801 S. Towne Ave, Pomona, CA 91766

Tel: (626) 961-8686

www.impex-fitness.com

info@impex-fitness.com

TABLE OF CONTENTS

BEFORE YOU BEGIN.....	1
IMPORTANT SAFETY NOTICES.....	2
EXERCISE GUIDELINES.....	3
WARNING LABEL PLACEMENT.....	5
IMPORTANT ASSEMBLY INFORMATION.....	6
OPERATIONS NOTES, CARE AND MAINTANENCE, WEIGHT CAPACITY.....	7
PARTS LIST.....	9
EXPLODED DIAGRAM.....	12
WEIGHT RESISTNACE CHART.....	13
WARRANTY.....	14
ORDERING PARTS.....	14

BEFORE YOU BEGIN

Thank you for selecting the MARCY FIT Deluxe HOME GYM MFM-8250 by IMPEX[®] INC. For your safety and benefit, read this manual carefully before using the equipment. As a manufacturer, we are committed to provide you complete customer satisfaction. If you have any questions, or find there are missing or damaged parts, we guarantee you complete satisfaction through direct assistance from our factory. To avoid unnecessary delays, *please call our customer service number*. Our Customer Service Agents will provide immediate assistance to you.

Customer Service Number
1-626-961-8686
Mon. – Fri. 9 a.m. – 5 p.m. PST
www.impex-fitness.com
info@impex-fitness.com

IMPORTANT SAFETY NOTICE

This exercise equipment is built for optimum safety. However, certain precautions apply whenever you operate a piece of exercise equipment. Be sure to read the entire manual before you assemble or operate your equipment. In particular, note the following safety precautions:

1. **Keep children and pets away from the equipment at all times. DO NOT leave children unattended in the same room with the equipment.**
2. Only one person at a time should use the equipment.
3. If the user experiences dizziness, nausea, chest pain, or any other abnormal symptoms, STOP the workout at once. CONSULT A PHYSICIAN IMMEDIATELY.
4. Position the equipment on a clear, leveled surface. DO NOT use the equipment near water or outdoors.
5. Keep hands away from all moving parts.
6. Always wear appropriate workout clothing when exercising. DO NOT wear robes or other clothing that could become caught in the equipment. Running or aerobic shoes are also required when using the equipment.
7. Use the equipment only for its intended use as described in this manual. DO NOT use attachments not recommended by the manufacturer.
8. Do not place any sharp object around the equipment.
9. Disabled person should not use the equipment.
10. Before using the equipment to exercise, always do stretching exercises to properly warm up.
11. Never operate the equipment if the equipment is not functioning properly.
12. A spotter is recommended during exercise.
13. **This equipment is designed and intended for home and consumer use only, not for commercial use.**

WARNING: BEFORE BEGINNING ANY EXERCISE PROGRAM, CONSULT YOUR PHYSICIAN. THIS IS ESPECIALLY IMPORTANT FOR INDIVIDUALS OVER THE AGE OF 35 OR PERSONS WITH PRE-EXISTING HEALTH PROBLEMS. READ ALL INSTRUCTIONS BEFORE USING ANY FITNESS EQUIPMENT. IMPEX INC. ASSUMES NO RESPONSIBILITY FOR PERSONAL INJURY OR PROPERTY DAMAGE SUSTAINED BY OR THROUGH THE USE OF THIS PRODUCT.

SAVE THESE INSTRUCTIONS.

EXECISE GUIDELINES

Building Muscle and Gaining Weight

Unlike aerobic exercise, which emphasizes endurance training, anaerobic exercise focuses on strength training. A gradual weight gain can occur while building the size and strength of muscles. While developing muscle mass, your body adapts to the stress placed upon it. You can modify your diet to include foods such as meat, fish and vegetables. These foods help muscles recover and replenish important nutrients after a strenuous workout.

Muscle Strength and Endurance

To achieve the greatest benefit from exercise, it is important to develop an exercise program that allows you to work all of the major muscle groups equally.

To increase muscles strength; follow this principle:

Increasing resistance and maintaining the number of repetitions of an exercise results in increased muscle strength.

To tone your body, follow the principle: Decreasing resistance plus increasing the number of repetitions of an exercise results in increased body tone.

Once you feel comfortable with an exercise, you can change the resistance, the number of repetitions, or the speed at which you do the exercise. It is not necessary to change all three variables. For example, let's say that you are training at 50 lbs and performing the exercise 10 times in 3 minutes. When this becomes too easy, you may decide to move up lifting 60 lbs for the same number of repetitions in the same amount of time. Lifting more weights fewer times most often develops muscle strength. To gain both muscle strength and endurance, it is recommended that you perform each exercise 15 to 20 reps per set.

Training Intensity

How hard you begin to train depends on your overall level of fitness. The soreness you experienced can be lessened by decreasing the load you place on your muscles and by performing fewer sets. To avoid injury, you should gradually work into an exercise program and set the load to your individual fitness level. The load should increase as your fitness level increases.

Muscle soreness is common, especially when you first start exercising. If you are painfully sore for a long time, it may be time to change your program. Eventually, your muscle system will become accustomed to the stress and strain placed on it.

Beginning a Strength Building Program

Warming Up

To begin strength training, it is important to stretch and perform light exercise for 5 to 10 minutes. This helps prepare the body for more strenuous exercise by increasing circulation, raising your body temperature and developing more oxygen to your muscles.

Workout

Each workout to keep in mind that muscle soreness that lasts for a long period is not desirable and may mean that injury has occurred.

Cool Down

At the end of each workout, perform slow stretching exercises for 5 to 10 minutes. Ease into each stretch only going as far as you can. This stage allows your muscles wind down after training.

To provide a total workout program it is also recommended that 2 to 3 days of aerobic exercise is performed in addition to the strength training.

Drinking Water

For the body to function properly, it must be properly hydrated. If you are exercising, you should increase your fluid intake. The reason for this is that the water you take in will leave your system through the sweating mechanism that cools your body during exercise. The water you lose through exercise must be replaced so that the muscles can recover properly.

Rest Day

Although you may not feel like doing it, taking a rest day at least once a week is important because it gives your body a chance to heal itself. Continuously working your muscle will result in over training which will not benefit in the long run.

WARNING LABEL PLACEMENT

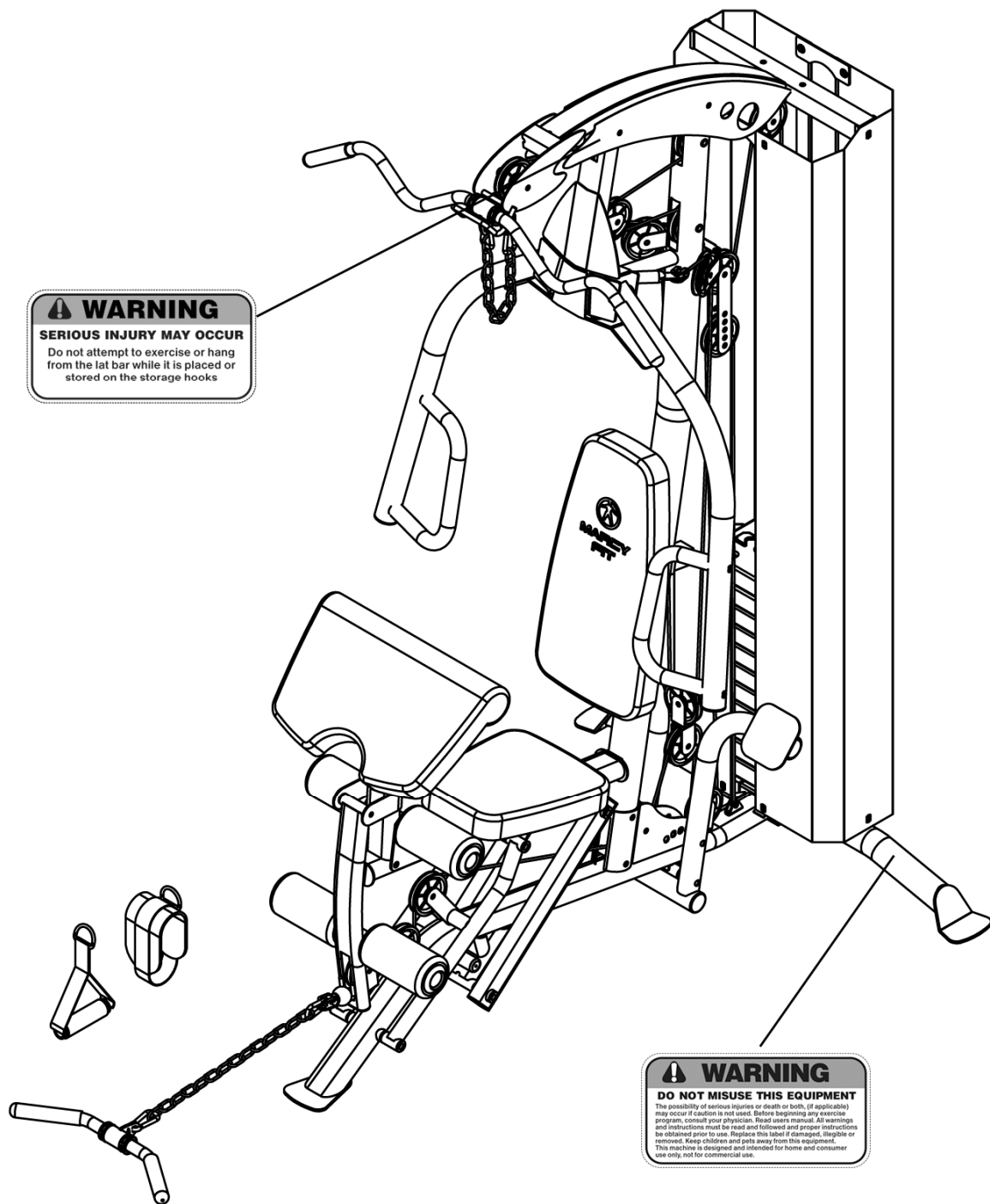

The warning labels shown here have been placed on the Rear Base and Upper Frame. If the labels are missing or illegible, please call customer service at 1-800-888-8899 for replacements. Apply the labels in the location shown.

IMPORTANT ASSEMBLY INFORMATION

- ❖ Tools Required for Assembling the Bench: Two Adjustable Wrenches and Allen Wrenches.
- ❖ NOTE: It is strongly recommended that this equipment is assembled by two or more people to avoid possible injury.
- ❖ Ensure **Carriage Bolts** are inserted through the **SQUARE holes** on components that need to be assembled. Attach washer only to end of the Carriage Bolt.
- ❖ Use **Allen Bolts or Hex Bolts** inserted through the **ROUND hole** on components that need to be assembled.
- ❖ Always wait until all bolts are assembled onto the bench before tightening the bolts. Do not tighten each bolt right after it is installed

Fasten Nuts and Bolts

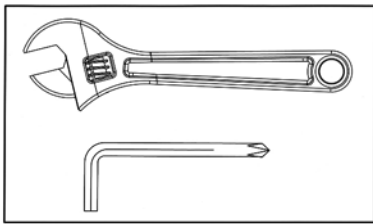

Securely tighten all Nuts and Bolts after all components have been assembled in current and previous steps.
NOTE: Do not over tighten any component with pivoting function.
Make sure all pivoting components are able to move freely.

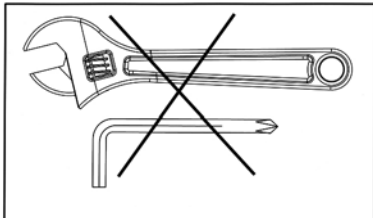

Do not tighten all Nuts and Bolts in this step.

Weight Plate Installation

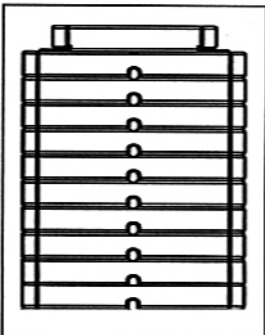

Slide weight plates onto Guide Rod from top to bottom.
The deep groove on each weight plate needs to face backwards and downwards.

OPERATION NOTES

Weight Plate Selection

1. Use the Weight Selector Pin to select the number of weight plates to exercise.
2. Do not insert weight selector pin while the weight stack or top plate is in elevated position.
3. Be certain the weight Selector Pin is completely inserted.
4. Each Weight Plate weights approximately 16 lbs.
5. Please refer to Weight Resistance Chart page.
6. Never use dumbbells or other means to increase the weight resistance. Use only weight plates provided by manufacturer.
7. **For safety purpose while the equipment is not in use. Insert the Lock Pin into the hole on Guide Rod, and use Combination Lock to lock the Pin to prevent the movement of Weight Plates.** Please refer to the Combination Lock set up.

Cable Tension Adjustment

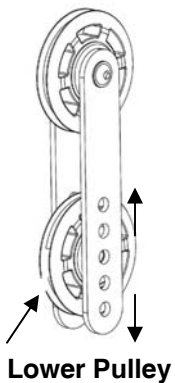

Adjust the tension of the Cable System by moving the position of lower Pulley on the Double Floating Pulley Brackets.

If the tension is too loose, move the lower pulley up by one notch.

If the tension is too tight, move the lower pulley down by one notch.

Arm Curl Pad Adjustment

Pull up and flip the Arm Curl Pad along the track on the Arm Curl Stand to face toward back when doing Leg Press exercises.

Do not over tighten Allen Bolt (#90) so the Bolt can move along the track smoothly.

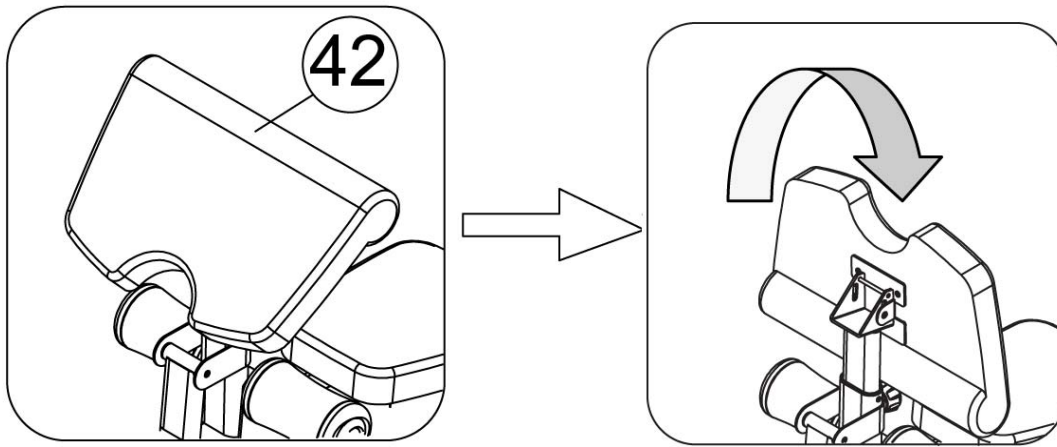

CARE AND MAINTENANCE

1. Lubricate moving parts with WD-40 or light oil periodically.
2. Inspect and tighten all parts before using the equipment.
3. The equipment can be cleaned using a damp cloth and mild non-abrasive detergent.
DO NOT use solvents.
4. Examine the equipment regularly for signs of damages or wear.
5. Replace any defective components immediately and/or keep the equipment out of use until repair.
6. **Failure to examine regularly may affect the safety level of the equipment.**

WEIGHT CAPACITY AND DIMENSION

1. Maximum user weight: 300 lbs.
2. Assembled Dimension: 61" x 45" x 81.5"

MFM-8250 PARTS LIST

PART NO	DESCRIPTION	SIZE	QUANTITY
1	Rear Base		1
2	Base Frame		1
3	Vertical Frame		1
4	Upper Frame		1
5	Front Press Base		1
6	Left Butterfly Bracket		1
7	Right Butterfly Bracket		1
8	Butterfly Arm		2
9	Butterfly Handle		2
10	Leg Press Assembly		1
11	Seat Support		1
12	Rear Leg Press Linkage Bar		2
13	Left Leg Press Linkage Tube		1
14	Right Leg Press Linkage Tube		1
15	Leg Developer		1
16	Guide Rod		2
17	Arm Curl Stand		1
18	Leg Press Plate		2
19	Angled Floating Pulley Bracket		1
20	Swivel Pulley Bracket		2
21	Selector Rod		1
22	Rotating Handle		2
23	Lat Bar		1
24	Shiver Bar		1
25	Arm Curl Pad Bracket		1
26	Swivel Pulley Bracket Frame		1
27	Foam Tube		2
28	Double Floating Pulley Bracket		2

29	Left Weight Stack Cover		1
30	Right Weight Stack Cover		1
31	Connecting Bracket		3
32	Single Handle		1
33	Plastic Ring		8
34	Weight Plate	16lb	10
35	Selector Stem	10lb	1
36	Weight Selector Pin		1
37	Upper Cable	134"	1
38	Lower Cable	162"	1
39	Butterfly Cable	110"	1
40	Seat Pad		1
41	Backrest Board		1
42	Arm Curl Pad		1
43	Ankle Strap		1
44	Lock Knob		2
45	Butterfly Axle	Ø ¾" x 3 ¼"	1
46	Leg Developer Axle	Ø 5/8" x 3 1/8"	1
47	Upper Frame Panel		2
48	Chain	10-link	1
49	Chain	15-link	1
50	Handle Grip	6"	4
51	Lat Bar Grip	20 7/8"	2
52	Leg Press L-shaped Lock Pin	8"	1
53	Backrest Support Frame		1
54	Cable Connector		2
55	Hook		4
56	Butterfly Arm End Cap	Ø2"	2
57	End Cap	PT30 x 2 ¾"	5
58	End Cap	Ø 1 ¾"	4
59	End Cap	Ø1"	4
60	Cone-shaped End Cap	Ø1"	1
61	End Cap	1" x 2"	2
62	End Cap	1 ½" x 1 ½"	1
63	Foam Roll End Cap		4
64	Foam Roll		4
65	Sleeve	PT40 x 3 1/8"	1
66	Pulley		14
67	Cable Retainer Bushing		20
68	Cable Retainer		20
69A	Vertical Frame Pulley		2
69B	Vertical Frame Pulley Cover		4
70	Front Press Base Bushing	Ø 1 ½" x 7/8"	2

71	Rubber Bumper	Ø 1 ½" x 5/8"	1
72	Rubber Bumper	Ø 2 ½" x 1"	2
73	Rubber Bumper	1 7/8" x 1 7/8"	2
74	Bushing	Ø1" x Ø ½"	34
75	Bushing	Ø1" x Ø 5/8"	2
76	Allen Bolt	M12 x 8 ½"	4
77	Allen Bolt	M12 x 8 ¼"	1
78	Allen Bolt	M12 x 5 3/8"	2
79	Allen Bolt	M12 x 3 ½"	2
80	Allen Bolt	M10 x 4"	3
81	Allen Bolt	M10 x 3 ¾"	2
82	Allen Bolt	M10 x 3"	1
83	Allen Bolt	M10 x 2 ½"	2
84	Allen Bolt	M10 x 2 1/8"	10
85	Allen Bolt	M10 x 1 ¾"	2
86	Allen Bolt	M10 x 1 3/8"	2
87	Allen Bolt	M10 x 1 1/8"	1
88	Allen Bolt	M10 x 1"	4
89	Allen Bolt	M10 x ¾"	8
90	Allen Bolt	M8 x 3 ½"	1
91	Allen Bolt	M8 x 2 1/8"	2
92	Allen Bolt	M8 x 1 5/8"	2
93	Allen Bolt	M8 x 5/8"	2
94	Allen Bolt	M6 x ¾"	2
95	Carriage Bolt	M10 x 2 ½"	2
96	Carriage Bolt	M10 x 3 ¾"	2
97	Philips Screw	M6 x 5/8"	1
98	Rivet		8
99	Large Washer	Ø1 1/8"	12
100	Washer	Ø1"	18
101	Washer	Ø ¾"	61
102	Washer	Ø 5/8"	8
103	Aircraft Nut	M12	9
104	Aircraft Nut	M10	26
105	Aircraft Nut	M8	1
106	Aircraft Nut	M6	2
107	Linkage Tube Connecting Rod		1
108	Rubber Bumper	Ø1 1/8" x 2"	2
109	Allen Bolt	M10 x 5/8"	12

EXPLODED DIAGRAM

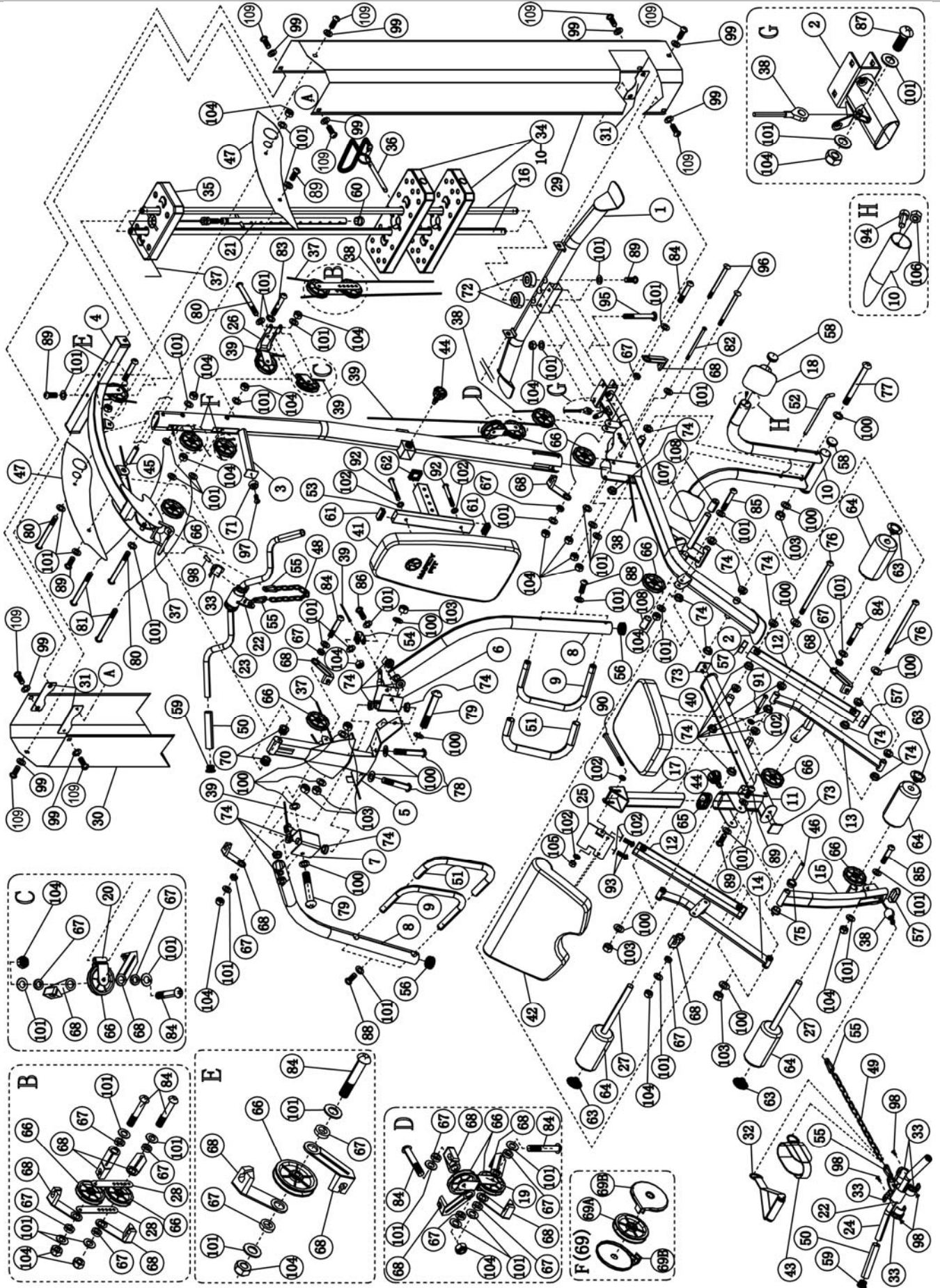

MFM-8250 WEIGHT RESISTANCE CHART					
Weight	Leg	Front	Butterfly	Lat Pull	Low
1	220	30	10	26	30
2	240	50	20	40	50
3	260	70	30	66	70
4	280	90	40	80	90
5	300	110	50	96	110
6	320	130	60	110	130
7	340	150	70	130	150
8	360	170	80	150	170
9	380	190	90	170	190
10	400	210	100	190	210

Note:Each plate weights 16 lbs.

Numbers are approximate.Actual weights may vary.

Values for Butterfly are for each arm.

IMPEX[®] INC.

LIMITED WARRANTY

IMPEX Inc. ("IMPEX[®]") warrants this product to be free from defects in workmanship and material, under normal use and service conditions, for a period of two years on the Frame from the date of purchase. This warranty extends only to the original purchaser. IMPEX's obligation under this Warranty is limited to replacing or repairing, at IMPEX's option.

All returns must be pre-authorized by IMPEX. Pre-authorization may be obtained by calling IMPEX Customer Service Department at 1-800-999-8899. All freights on products returned to IMPEX must be prepaid by the customer. This warranty does not extend to any product or damage to a product caused by or attributable to freight damage, abuse, misuse, improper or abnormal usage or repairs not provided by an IMPEX authorized service center or for products used for commercial or rental purposes. No other warranty beyond that specifically set forth above is authorized by IMPEX.

IMPEX is not responsible or liable for indirect, special or consequential damages arising out of or in connection with the use or performance of the product or other damages with respect to any economic loss, loss of property, loss of revenues or profits, loss of enjoyments or use, costs of removal, installation or other consequential damages or whatsoever natures. Some states do not allow the exclusion or limitation of incidental or consequential damages. Accordingly, the above limitation may not apply to you.

The warranty extended hereunder is in lieu of any and all other warranties and any implied warranties of merchantability or fitness for a particular purpose is limited in its scope and duration to the terms set forth herein. Some states do not allow limitations on how long an implied warranty lasts. Accordingly, the above limitation may not apply to you.

This warranty gives you specific legal right. You may also have other rights which vary from state to state. Register on-line at www.impex-fitness.com

IMPEX[®] INC.
2801 S. Towne Ave.
Pomona, CA 91766

ORDERING REPLACEMENT PARTS

Replacement parts can be ordered by calling our Customer Service Department at **1-626-961-8686** during our regular business hours: Monday through Friday, 9 am until 5 pm Pacific standard time.

info@impex-fitness.com

When ordering replacement parts, always give the following information.

1. Model
2. Description of Parts
3. Part Number
4. Date of Purchase

Free Manuals Download Website

<http://myh66.com>

<http://usermanuals.us>

<http://www.somanuals.com>

<http://www.4manuals.cc>

<http://www.manual-lib.com>

<http://www.404manual.com>

<http://www.luxmanual.com>

<http://aubethermostatmanual.com>

Golf course search by state

<http://golfingnear.com>

Email search by domain

<http://emailbydomain.com>

Auto manuals search

<http://auto.somanuals.com>

TV manuals search

<http://tv.somanuals.com>