

**TRM10s**  
**TRM12s**



**Installation & Operation**

**Hafler**®

**trans•ana**▶

**DESIGNED AND  
ASSEMBLED IN THE  
USA**

**SUBWOOFER MONITORING SYSTEM**

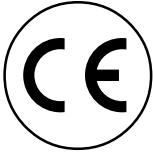

## Declaration of Conformity

Application of Council Directive: 73/23/EEC (low voltage directive)

Standard(s) to which Conformity is Declared: EN55013-1

EN55103-2

EN60065 (safety)

Manufacturer's Name: Hafler

Manufacturer's Address: 546 South Rockford Drive, Tempe, Arizona 85281

Importer's Name: \_\_\_\_\_

Importer's Address: \_\_\_\_\_

Type of Equipment: 2-channel Audio Power Amplifier/Speaker

Model No.:  TRM10s  TRM12s

Serial Number: \_\_\_\_\_

Year of Manufacturing:  1998  1999  2000  2001  2002

*I, the undersigned, hereby declare that the equipment specified above conforms to the above Directive(s) and Standard(s)*

Place: Hafler

Date: 12/01/98

James C. Strickland, VP Engineering

# PERFORMANCE SPECIFICATIONS

## SUBWOOFER MODEL

<b>Free Field Frequency Response</b>	27Hz-110Hz, $\pm 2$ dB
<b>Peak Acoustic Output</b>	$\geq 112$ dB (w/music @ 2m)
<b>Total Harmonic Distortion (THD)</b>	<3%, 30Hz-90Hz (90dB @ 2m)
<b>Low Frequency Driver</b>	10" (254mm) Cellulose Fibre Cone Santoprene Rubber Surround 2" (51mm) 4-Layer Voice Coil 30 oz. Magnet
<b>Cabinet</b>	1.0ft <sup>3</sup> (28 Liter) Vented Down Firing
<b>Dimensions</b>	14.75"(H) x 16"(W) x 16"(D) (37.46cm x 40.64cm x 40.64cm)
<b>Net Weight</b>	53 lbs. (24kg)

## TRM10s

## TRM12s

<b>Free Field Frequency Response</b>	25Hz-110Hz, $\pm 2$ dB
<b>Peak Acoustic Output</b>	$\geq 115$ dB (w/music @ 2m)
<b>Total Harmonic Distortion (THD)</b>	<3%, 25Hz-90Hz (90dB @ 2m)
<b>Low Frequency Driver</b>	12" (305mm) Cellulose Fibre Cone Santoprene Rubber Surround 2.5" (63.5mm) 4-Layer Voice Coil 102 oz. Magnet
<b>Cabinet</b>	2.0ft <sup>3</sup> (56 Liter) Vented Down Firing
<b>Dimensions</b>	18.25"(H) x 19.50"(W) x 19.375"(D) (46.35cm x 49.53cm x 49.21cm)
<b>Net Weight</b>	94 lbs. (42kg)

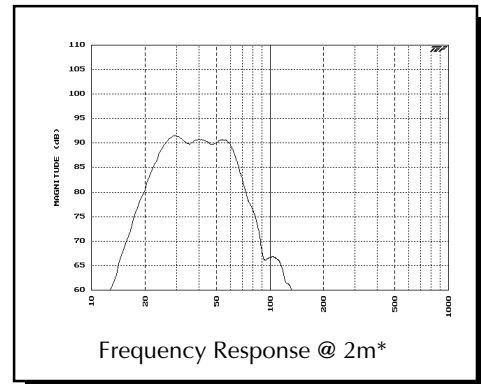
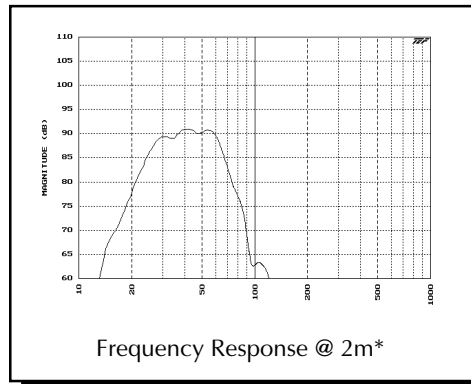

\*Frequency response generated with 60Hz low pass crossover engaged

## AMPLIFIER SECTION

<b>Power Rating</b>	200 W RMS @ 4 ohms
<b>Signal-to-Noise</b>	>100dB
<b>CMRR</b>	>70dB typical @ 60Hz
<b>Input Impedance</b>	47k $\Omega$ per phase balanced, 47k $\Omega$ unbalanced
<b>Input Sensitivity Range</b>	160mV to 5V (unbalanced) 80mV to 2.5V (per phase balanced)
<b>Gain</b>	+45dB max. to +15dB min.
<b>Power Consumption</b>	Idle Power: 11W / 150mA @ 120 VAC Idle Power: 11W / 90mA @ 230 VAC Normal Operation: 68W / 770mA @ 120 VAC Normal Operation: 66W / 380mA @ 230VAC Full Power: 330W / 3.3A @ 120VAC Full Power: 315W / 1.7mA @ 230VAC
<b>Rear Panel</b>	Balanced XLR Inputs Unbalanced RCA Inputs Gain Control (30dB range) Low Pass Crossover (variable 40Hz~140Hz) Phase DIP Switches (0°, -90°, -180°, -270°)

### TRM10s Dimensions

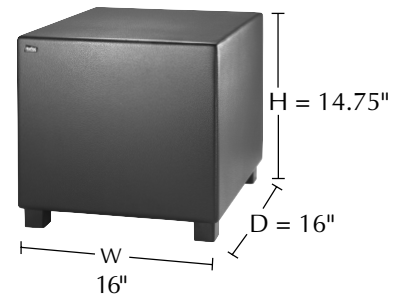

### TRM12s Dimensions

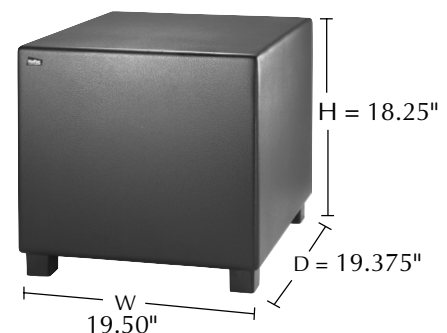

## LOW-PASS CROSSOVER SECTION

<b>Crossover Frequency</b>	Variable from 40Hz~140Hz
<b>Crossover Slope</b>	24dB/octave (4th order) Linkwitz-Riley
<b>Subsonic Filter</b>	12dB/octave (-3dB @ 18Hz)

Specifications are subject to change without notice.

# NOTICE - IMPORTANT SAFETY INFORMATION



**WARNING: TO PREVENT FIRE OR SHOCK HAZARD  
DO NOT EXPOSE THIS EQUIPMENT TO RAIN OR MOISTURE.**

The lightning flash with arrowhead symbol within an equilateral triangle is intended to alert the user to the presence of uninsulated "dangerous voltage" within the product's enclosure, that may be of sufficient magnitude to constitute a risk of electric shock to persons.

The exclamation point within an equilateral triangle is intended to alert the user of the presence of important operating and maintenance (servicing) instructions in the literature accompanying the appliance.

## 1. READ INSTRUCTIONS

All the safety and operating instructions of your Hafler equipment should be read before power is applied to the equipment.

## 2. RETAIN OWNER'S MANUAL

These safety and operating instructions should be retained for future reference.

## 3. HEED WARNINGS

All warnings on the equipment and in the operating instructions are important and should be followed.

## 4. FOLLOW INSTRUCTIONS

All operating and use instructions are important and should be followed.

## 5. HEAT

The equipment should be kept away from areas of high temperature, i.e., heater vents, radiators, stoves/ovens, fireplaces, etc.

## 6. VENTILATION

The equipment should be used in an area suitable for proper ventilation. Care should be taken not to impede airflow in and around the cabinet.

## 7. WATER AND MOISTURE

The equipment should not be used in or around water, such as a bathtub, sink, or swimming area. Also, the equipment should not be used in areas prone to flooding, such as a basement.

## 8. POWER SOURCES

The equipment should be connected only to a power source of the same voltage and frequency as that listed on the rear panel above the power cord entry point.

## 9. POWER CORD PROTECTION

Power cords should be arranged so they do not interfere with the movement of objects in the room: people, fan blades, utility carts, etc. Also, care should be taken that the cord is not pinched or cut, and placed so it is not in danger of being pinched or cut, as in under a rug, around a tight corner, etc.

## 10. POWER CORD GROUNDING

The power supply cord is of a three wire grounded type, designed to reduce the risk of electric shock sustained from a live cabinet. It is assumed to be of suitable length for most uses of the equipment. The use of extension cords and power strips is discouraged unless they are of suitable rating to deliver the required total current for safe operation of all connected equipment. Furthermore, extension cords or power strips must provide the same three wire grounded

connection. It is important that the blades of the equipment's plug be able to fully insert into the mating receptacle. **Never remove the round grounding pin on the plug in an attempt to mate to a two wire ungrounded receptacle:** use a grounding adaptor with the grounding tab or wire suitably connected to earth ground.

## 11. NON-USE PERIODS

During periods of extended non-use, the power cord should be unplugged from the power source.

## 12. CLEANING

The equipment should be cleaned only as detailed in the operating instructions.

## 13. OBJECT AND LIQUID ENTRY

Care should be taken so that objects and/or liquids, such as cleaning fluids or beverages, are not spilled into the enclosure of the equipment.

## 14. DAMAGE REQUIRING SERVICE

Hafler equipment should be serviced by qualified service personnel when:

- A. The power supply cord or plug has been damaged, or
- B. Objects have fallen onto, or liquid has been spilled into the equipment, or
- C. The equipment has been exposed to rain, or
- D. The equipment does not appear to operate normally or exhibits a marked change in performance, or
- E. The equipment has been dropped, or the enclosure has been damaged.

## 15. SERVICING

The user should not attempt to service the equipment beyond that which is described in the operating instructions. All other service should be referred to qualified service personnel.

## 16. CARTS AND STANDS

The equipment should be used with carts or stands only of sufficient strength and stability for the use intended.

An equipment and cart combination should be moved with care. Quick stops and starts, excessive force, and uneven surfaces may cause the equipment and cart combination to topple.

## ADVERTENCIA – INFORMACION DE SEGURIDAD IMPORTANTE



El símbolo de flecha relámpago dentro de un triángulo equilátero, es para alertar al usuario de la presencia de “voltajes peligrosos” no aislados en el interior del aparato, los cuales pueden ser de suficiente magnitud para constituir un riesgo de choque eléctrico a las personas.

El símbolo de exclamación dentro de un triángulo equilátero, es para alertar al usuario de la presencia de instrucciones importantes de operación y mantenimiento (servicio) en la documentación que acompaña al equipo.

### 1. LEA LAS INSTRUCCIONES

Todas las instrucciones de seguridad y operación de su equipo Hafler, deben ser leídas antes de que el equipo sea conectado eléctricamente.

### 2. CONSERVE EL MANUAL DEL PROPIETARIO

Estas instrucciones de seguridad y operación, deben ser conservadas para futuras referencias.

### 3. CUADROS DE ADVERTENCIAS

Todas las advertencias en el equipo y en las instrucciones de operación, son importantes y deben ser seguidas.

### 4. SIGA LAS INSTRUCCIONES

Todas las instrucciones de uso y operación son importantes y deben ser seguidas.

### 5. CALOR

El equipo debe ser mantenido lejos de áreas de alta temperatura, como por ejemplo: ventilaciones de calentadores, radiadores, estufas/hornos, hogueras, etc.

### 6. VENTILACION

El equip debe ser usado en áreas con ventilación adecuada. Deben er tomadas las precauciones necesarias para no impedir el flujo de aire dentro y alrededor del aparato.

### 7. AGUA Y HUMEDAD

El equipo no debe ser usado en el agua ó alrededor de ésta, tales como en una bañera, tanque o áreas de nado. También, el equipo no debe ser usado en áreas propensas a inundaciones, tales como en un sótano.

### 8. FUENTES DE PODER

El equipo debe ser conectado a una fuente de poder del mismo voltaje y frecuencia que el indicado en el panel trasero sobre el punto de entrada del cable de corriente.

### 9. PROTECCION DEL CABLE DE CORRIENTE

Los cables de corriente deben ser dispuestos de forma tal que no interfieran con el movimiento de objetos en la sala: personas, aspas de ventilación, carretillas, etc. También, es necesario tener cuidado de que el cable no esté punzado o cortado, y debe estar ubicado de forma tal que esto no ocurra, como podría suceder debajo de una alfombra o al pasar el cable por una esquina aguda, etc.

### 10. ATERRAMIENTO DEL CABLE DE CORRIENTE

El cable de corriente es del tipo aterrado de tres hilos, diseñado para reducir el riesgo de una descarga eléctrica procedent de un chasis energizado. Se asume que su longitud es suficiente para la mayoría de usos del equipo. El uso de extensiones y multienchufes no es recomendado, a menos que tengan el amperaje adecuado para

poder suministrar la corriente requerida pra la operación segura de todo el equipo conectado. Aun más, las extensiones deben proveer de la misma coneción aterrada de tres hiles. Es importante que el enchufe se pueda introducir completamente en el receptáculo. Nunca remeva el pin de aterramiento en un intento por conectar el cable en un receptáculo de dos hilos no aterrado: use un adaptador de aterramiento que esté adecuadamente conectado a un punto de tierra.

### 11. PERIODOS SIN USO

Durante periodos prolongados sin uso del equipo, el cable de corriente debe ser desconectado de la fuente de electrixidad.

### 12. LIMPIEZA

El equip debe ser limpiado solo en la forma que se detalla en las instrucciones de operación.

### 13. INTRODUCCIÓN DE OBJETOS Y LIQUIDO

Deben ser tomadas precauciones con el fin de que objetos y/ó líquidos, tales como fluidos de limpieza y gaseosas, no sean derramados dentro del chasis del aparato.

### 14. DAÑOS QUE REQUIEREN DE SERVICIO

Los equipos Hafler deben ser llevados a servicio por personal calificado cuando:

- A. El cable de corriente ó el enchufe haya sido dañado, ó
- B. Objetos ó líquido hayan sido introducidos ó derramado en el equipo, ó
- C. El equipo haya sido expuesto a lluvia, ó
- D. El equipo aparenta no operar normalmente ó exhibe un marcado cambio en su desempeño, ó
- E. El equipo se ha caído, o el chasis ha sido golpeado.

### 15. SERVICIO

El usuario no deberá intentar darle servicio al equipo más allá de lo que está descrito en el instructivo de operación. Todo lo demás, deberá ser referido a servicio por personal calificado.

### 16. CARRETIILLAS Y SOPORTES

El equipo podrá ser usado con carretillas y soportes que tengan la fortaleza y estabilidad suficiente para el uso previsto.

La combinación equipo/carretilla deberá ser movida con cuidado. Rápidas paradas y arranques, excesiva fuerza y superficies imparejas, pueden causar el volcamiento del conjunto de carretilla/equipo.

# ATTENTION: INFORMATIONS IMPORTANTES DE SÉCURITÉ



La lumière clignotante du symbole de la flèche à l'intérieur d'un triangle équilatéral, à pour objet d'alerter l'utilisateur de la présence "d'un voltage dangereux" non-isolé à l'intérieur du produit, qui pourrait être de magnitude suffisante au risque d'électrocution.

Le point d'exclamation, à l'intérieur d'un triangle équilatéral, à pour objet de prévenir l'utilisateur de l'importance des instructions de fonctionnement et de maintenance, jointes à l'appareil.

## 1. LIRE LES INSTRUCTIONS

Le mode d'emploi et les mesures de sécurité de votre équipement Hafler devraient être consultés avant sa mise en marche.

## 2. CONSERVER LE GUIDE DE L'UTILISATEUR

Le mode d'emploi et les mesures de sécurité devraient être conservés pour des références futures.

## 3. CONSIDÉRATIONS DE MISE EN GARDE

Le mode d'emploi et les mises en garde concernant cet équipement sont de grande importance et devraient être suivis.

## 4. SUIVRE LE MODE D'EMPLOI

Le mode d'emploi et les conseils d'utilisation sont importants et devraient être suivis.

## 5. CHALEUR

Le matériel devrait être préservé loin de toute source de chaleur: radiateurs, cuisinière/fours, cheminées,...etc.

## 6. VENTILATION

Le matériel devrait être utilisé dans un endroit à bonne ventilation. Il reste nécessaire de respecter la circulation de flux d'air à l'intérieur et autour du meuble.

## 7. EAU ET HUMIDITÉ

Le matériel ne devrait pas être utilisé près d'une source d'eau, telle qu'une baignoire, un évier, ou une aire de baignade. De plus, le matériel ne devrait pas être utilisé dans des lieux sujets aux inondations, tels que les sous-sols.

## 8. SOURCES D'ÉNERGIE

Le matériel devrait seulement être relié à une source d'énergie de même voltage et fréquence que celle indiquée sur le tableau arrière, au dessus de la fiche d'entrée de la prise de courant.

## 9. PROTECTION DE LA PRISE DE COURANT

La prise de courant devrait être arrangée de façon à ne pas interférer avec le déplacement d'objets (chariots, pales de ventilateurs...etc.) ou de personnes à l'intérieur de la pièce. D'autre part, il faudrait faire très attention à ce que la prise ne soit pas percée ou coupée, ou disposée de façon à risquer de l'être, comme sous un tapis, autour d'un angle pointu...etc.

## 10. PRISE DE COURANT À TROIS FICHES

La prise de courant est composée de trois fiches, désignées à réduire le risque de décharge électrique de l'appareil.

Elle devrait être de longueur suffisante pour la plupart des utilisations de ce matériel. L'utilisation de rallonge et d'adaptateur est déconseillée à moins d'être en mesure de fournir la charge électrique requise à un fonctionnement sans risque, de tout matériel relié.

## 11. PÉRIODES DE NON-UTILISATION

Durant les périodes de non-utilisation, la prise de courant ne devrait pas être branchée à une source d'énergie.

## 12. NETTOYAGE

Le matériel devrait être nettoyé en respectant les instructions indiquées.

## 13. PENÉTRATION DES LIQUIDES

Une attention particulière est exigée quant à la dispersion de liquides tels que les produits de nettoyage et boissons, de façon à éviter toute pénétration dans l'enceinte du matériel.

## 14. DÉGÂT NÉCESSITANT UNE RÉVISION

Le matériel Hafler devrait être révisé par des personnes qualifiées de service après-vente, lorsque:

- A. Les fiches ou la prise de courant ont été endommagés, ou:
- B. Des objets sont tombés sur le matériel, ou des liquides s'y sont dispersés, ou:
- C. Le matériel a été exposé à la pluie, ou:
- D. Le matériel ne semble pas fonctionner correctement, ou affiche un changement de performance, ou:
- E. Le matériel a été renversé à terre, ou l'enceinte a été endommagée.

## 15. RÉVISION

L'utilisateur ne devrait pas essayer de réviser le matériel en allant plus loin que ce qui a été décrit dans le mode d'emploi. Toute autre révision devrait être confiée à un personnel qualifié.

## 16. CHARRIOTS ET MEUBLES

Le matériel devrait être utilisé avec des chariots et meubles de qualité et stabilité suffisante à son utilisation préconçue.

L'ensemble du matériel et du charriot devrait être déplacé avec précaution. Des mises en marche et arrêts brusques, des collisions excessives ainsi que des surfaces inégales peuvent renverser l'ensemble du matériel et du charriot.

# ACHTUNG – WICHTIGE SICHERHEITS – INFORMATIONEN



Der Blitz mit dem Pfeil, in einem gleichschenkligen Dreieck, soll den benutzer vor unisolierter "gefährlicher Spannung" innerhalb des Gerätes warnen.

Das Ausrufezeichen, in einem gleichschenkligen Dreieck, soll den Benutzer darauf aufmerksam machen, daß dem Gerät wichtige Operations - und Service - Informationen beigefügt sind.

## 1. INSTRUKTIONEN LESEN

Alle Sicherheits- und Operationshinweise Ihres Hafler Equipments sollten vor der Inbetriebnahme gelesen werden.

## 2. BETRIEBSANLEITUNG AUFBEWAHREN

Bewahren Sie die Bedienungsanleitung sorgfältig auf, damit Sie in dieser auch in Zukunft nachschlagen können.

## 3. WARNUNGEN BEACHTEN

Alle Warnungen des Gerätes und der Bedienungsanleitung sind extrem wichtig und müssen befolgt werden.

## 4. INSTRUKTIONEN BEACHTEN

Alle Operations- und Gebrauchshinweise sind extrem wichtig und müssen beachtet werden.

## 5. HITZE

Das Equipment sollte fern von Hitze ausstrahlenden Geräten aufgestellt werden, wie z.B. Heizungen, Öfen etc.

## 6. VENTILATION

Das Equipment sollte so aufgestellt werden, daß eine ausreichende Ventilation gewährt wird.

## 7. WASSER UND FEUCHTIGKEIT

Das Equipment sollte nicht im oder in der Nähe von Wasser benutzt werden, wie z.B. in Schwimmbädern, Saunen etc. Es sollte ebenfalls nicht in Überschwämmungsgefährdeten Gebieten aufgestellt werden, wie z.B. Kellerräumen.

## 8. STROMANSCHLUß

Das Equipment darf nur an eine Stromversorgung angeschlossen werden, die die gleichen Parameter aufweist, welche auf der Rückseite, über em Anschlußterminal des Gerätes, aufgelistet sind.

## 9. SCHUTZ DER ZULEITUNG

Die Zuleitungen sollten so verlegt werden, daß diese nicht in den Bewegungsbereich anderer Möbelstücke oder Personen hereinragen. Achten Sie darauf, das das Kabel nicht gequetscht oder durchschnitten wird, wie z.B. unter Schränken oder an scharfen Kanten etc.

## 10. MASSEANSCHLUß

Das dreiadrige Anschlußkabel ist mit einem Erdungsleiter ausgestattet, welcher die Risiken eines Elektroshocks verringert. Das Kabel hat eine Länge, welche für die meisten Anwendungen völlig ausreicht. Wenn Sie Verlängerungskabel benutzen, achten Sie darauf, das dies die erforderlichen Ströme übertragen können. Benutzen Sie immer dreiadrige Verlängerungskable.

## 11. ZEITRÄUME IN DENE DAS GERÄT NICHT GENUTZT WIRD

Wird das Gerät über einen längeren Zeitraum nicht genutzt (z.B. Urlaub), ziehen Sie bitten den Netzstecker aus der Steckdose.

## 12. REINIGEN

Reinigen Sie das Gerät nur, wie in der Bedienungsanleitung detailliert beschrieben.

## 13. EINDRINGEN VON FREMDKÖRPERN

Achten Sie darauf, daß weder Fremdkörper, noch Flüssigkeiten in das Gerät eindringen.

## 14. ERFORDERLICHER REPARATURSERVICE

Hafler Equipment sollte nur von qualifizierten Service-Technikern instand gesetzt werden, wenn:

A. Das Stromversorgungskabel beschädigt wurde

B. Eine Flüssigkeit in das Gerät eingedrungen ist

C. Das Gerät Regen ausgesetzt wurde

D. Das Gerät nicht mehr ordnungsgemäß funktioniert, ggf. nicht mehr die volle Leistung abgibt

E. Das Gerät runtergefallen ist oder das Gehäuse beschädigt wurde

## 15. SERVICE

Der Benutzer sollte nur den Service ausführen, der in der Bedienungsanleitung für den Benutzer freigegeben wird. Den weiterführenden Service sollte nur von qualifizierten Technikern durchgeführt werden.

## 16. AUFSTELLUNG

Das Equipment sollte so aufgestellt werden, daß der gewählte Untergrund die erforderliche Stabilität aufweist, so daß eine gefahrlose Benutzung gewährleistet wird.

Das Equipment und der Untergrund sollte mit äußerster Vorsicht bewegt werden. Bei schnellen Bewegungen oder starkem Abbremsen, kann es zum Umkippen des Equipments kommen.

# NOTARE – IMPORTANTI INFORMAZIONI SULLA SICUREZZA



Il simbolo del fulmine in un triangolo equilatero vuole avvertire della presenza di tensioni elevate non isolate e di valore sufficiente per costituire rischio di shock elettrico alle persone.

Il punto esclamativo contenuto in un triangolo equilatero vuole avvertire l'utente della presenza di parti di servizio e di manutenzione che sono dettagliate nel manuale di istruzioni.

## 1. LEGGETE LE ISTRUZIONI

Tutte le istruzioni riguardanti la sicurezza ed il funzionamento devono essere lette prima di applicare tensione all'apparato.

## 2. CONSERVATE IL MANUALE

Queste istruzioni riguardanti la sicurezza ed il funzionamento devono essere conservate come riferimento futuro.

## 3. AVVERTENZE

Tutte le avvertenze poste sull'apparato e sul libretto di istruzioni sono importanti e devono essere seguite.

## 4. SEGUIRE LE ISTRUZIONI

Tutte le istruzioni operative e di funzionamento devono essere seguite.

## 5. TEMPERATURA

L'apparato deve essere mantenuto lontano da tutte le zone ad alta temperatura, termosifoni, termoconvettori, stufe e forni, caminetti ed altro.

## 6. VENTILAZIONE

L'apparato deve essere posizionato in aree convenienti per una corretta ventilazione. Prestare attenzione che sia consentita circolazione d'aria attorno e dentro il cabinet.

## 7. ACQUA E POLVERE

L'apparato deve essere posizionato lontano da zone contenenti acqua, come vasche a bagno, acquari e piscine. Inoltre non deve essere impiegato in aree soggette ad allagamento, come le cantine.

## 8. REQUISITI DI ALIMENTAZIONE

L'apparato deve essere connesso solo ad un'alimentazione della stessa tensione e frequenza di quanto scritto sulla parte posteriore del telaio.

## 9. PROTEZIONE DEL CAVO DI ALIMENTAZIONE

Il cavo di alimentazione deve essere posizionato in modo di non interferire con il movimento di oggetti nella stanza: persone, ventilatori, carrelli, ecc...prestate attenzione anche che il cavo non sia tagliato o spellato e che non possa tagliarsi e spellarsi.

## 10. MESSA A TERRA

Il cavo di alimentazione è del tipo a tre fili con terra ed è progettato per ridurre il rischio di shock elettrici. Si presume che sia della lunghezza sufficiente per la maggior parte degli impieghi. L'impiego di prolunghie e adattatori è sconsigliato se questi non garantiscono la potenza sufficiente per il corretto funzionamento degli apparati connessi. È altresì importante che vengano sempre impiegate prolunghie con la configurazione a tre fili con terra.

## 11. PERIODI DI NON UTILIZZO

Durante lunghi periodi di non utilizzo, staccare il cavo di alimentazione.

## 12. PULIZIA

L'apparato deve essere pulito solo come indicato dalle istruzioni.

## 13. INGRESSO DI OGGETTI E LIQUIDI

Si deve prestare attenzione che oggetti e liquidi, come fluidi detergenti e bibite, non vengano versati all'interno dell'apparato.

## 14. RIPARAZIONI

Gli apparati Hafler devono essere riparati da personale qualificato quando:

A. Il cavo di alimentazione o la spina sono danneggiati

B. Oggetti sono caduti all'interno del telaio o quando del liquido è entrato

C. Quando l'apparato è stato esposto a pioggia

D. Quando l'apparato non sembra funzionare normalmente o quando esibisce un cambiamento di prestazioni o

E. Quando è caduto o il telaio è stato danneggiato

## 15. ASSISTENZA

L'utente non deve tentare di prestare assistenza all'apparato, se non per quanto esposto nelle istruzioni. Tutti gli altri interventi devono essere effettuati da un tecnico specializzato.

## 16. CARRELLI E STAND

L'apparato deve essere impiegato su carrelli o stand solo se questi sono sufficientemente solidi e stabili per la funzione a cui si vuole dedicarli.

La combinazione di carrello ed apparato deve essere mossa con cautela. Fermate e partenze improvvise, forze eccessive e superfici irregolari, possono ribaltare la combinazione carrello e apparato.



# TABLE OF CONTENTS

<b>PERFORMANCE SPECIFICATIONS</b> .....	vi
Frequency Response Graphs .....	
<b>SAFETY PRECAUTIONS</b> .....	v
<b>INTRODUCTION</b> .....	1
<b>TECHNICAL DESIGN FEATURES</b> .....	1
<b>FRONT &amp; REAR PANEL VIEWS</b> .....	4
<b>SCHEMATIC DIAGRAMS</b> .....	5
<b>INSTALLATION</b>	
Location .....	9
Studio Installations .....	9
Home Theater Installations .....	9
Input Switch .....	10
XLR Wiring Configurations .....	10
<b>OPERATION</b>	
Auto Turn-On/Sleep Mode .....	11
Input Sensitivity .....	11
Low-Pass Crossover .....	11
Phase Control .....	12
AC Line .....	13
LED Indicator .....	13
Break-In and Warm Up .....	13
Cleaning and Maintenance .....	13
<b>SERVICE REFERENCE</b>	
PC Board Layout .....	14
Parts List .....	15
TRM10s/TRM12s Functional Block Diagrams .....	17
Input Circuit .....	17
Mono Sum/Gain Circuit .....	17
Phase Control Circuit .....	17
Buffer/Gain Trim Circuit .....	17
Filter Circuits .....	17
Class-G Trans•ana Amplifier .....	18
Soft Start Circuit .....	18
Power On/Off Circuit .....	19
Signal Sensing Turn-On Circuit .....	19
Thermal Protection .....	19
Circuit Calibration .....	20
Amplifier Replacement .....	21
Woofer Replacement .....	21
<b>WARRANTY</b> .....	22

# INTRODUCTION

Thank You and congratulations on your purchase of the HAFLER TRM10s/TRM12s reference monitor, the world's finest brand in professional audio equipment.

The **TRM10s** (Trans•ana Reference Monitor) is an amplified 10" subwoofer monitor. The **TRM12s** is an amplified 12" subwoofer monitor. Both models offer unmatched quality and performance in a truly professional grade product. The TRM10s/TRM12s are great for Professional Studios, Digital Work Stations, Broadcast Booths, and Home Project Studios.

Although we realize a professional such as yourself already knows a thing or two about pro audio, we urge you to read this manual to at least humor our technical writer. For ease of use, this manual is organized into three main sections: **Installation**, **Operation**, and **Service Reference**. "Installation" covers the set-up of your new HAFLER equipment in the system. "Operation" covers the controls and how to use them for optimum performance. "Service Reference" contains field service information useful for technicians and engineers.

## TECHNICAL DESIGN FEATURES

The TRM10s/TRM12s monitors utilize a specially designed amplifier featuring our innovative Trans•ana circuitry. This topology, with its unique input-to-output configuration (derived from our patented Trans•nova circuit), employs MOSFETs in both the power supply and output stages that result in superior sound quality.

The amplifier features an auto turn-on/off circuit that eliminates the need for a conventional power switch. Input signals can be fed into the amplifier via Balanced XLR jacks (where long cable runs are used) or into standard Un-Balanced RCA jacks (where short cable runs are used). Each pair of inputs is combined into a mono-summed signal before being fed into a 4th order Linkwitz-Riley low-pass crossover, variable from 40Hz~140Hz. If selected, the signal is then fed into the Phase Warp that allows the phase of the signal to be adjusted at 90°, 180°, or 270° increments.

The TRM10s features a 10" (254mm) low frequency transducer with a cone made from cellulose fibre. A santoprene rubber surround that is immune to temperature fluctuations controls woofer damping and reduces 2nd harmonic distortions for a very wide and flat frequency response. The transducer also features a 2" (51mm) 4-layer copper voice coil wound on an aluminum voice coil former and is driven by a 30 oz. magnet. The TRM12s features a 12" (305mm) low frequency transducer made with the same cellulose fibre cone and santoprene rubber surround. The 12" transducer features a 2.5" (63.5mm) 4-layer copper voice coil wound on an aluminum voice coil former driven by a 102 oz. magnet.

Both the TRM10s and TRM12s are downfiring subwoofer models and are vented using a radiused Aerovent for reduced turbulence. The cabinet is made from acoustically dead 19mm MDF material and is internally packed with damping material to eliminate internal resonance.

## MEHSA

(**M**aximum **E**fficiency **H**eat**S**ink **A**pplication) MEHSA is a proprietary process that yields up to 5 times better heat transfer than traditional FET mounting techniques using the exact same components. A multi-layer insulated metal substrate operating with minimal thermal resistance spreads heat both downward and outward to quickly dissipate heat from each device across the heatsink. This process combined with our DSM technology and MOSFET devices allows us to squeeze more watts per cubic inch from every output device as well as provide consistent thermal stability.

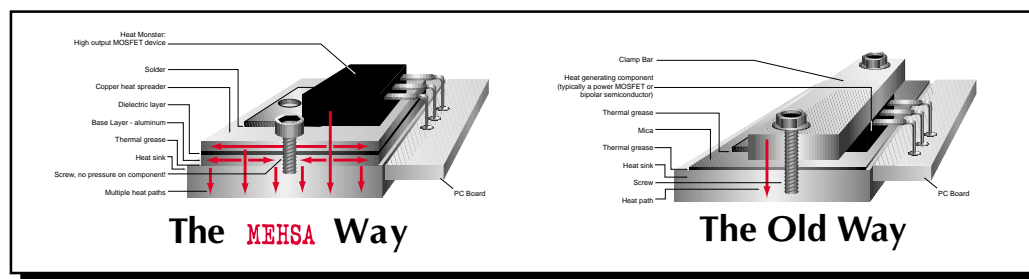

**THE RESULT:** Better reliability through faster heat dissipation.

## Trans•ana

Trans•ana (**T**RANSconductance **A**ctive **N**odal **A**mplifier) is a circuit that allows the audio signal to pass through the amplifier at low voltage. The signal is directly level-shifted to the fixed high voltage rails via a pair of driver transistors. Signal linearity is assured by an active node formed by the driver transistors at ultrasonic frequencies. This allows amplifier performance similar to Trans•nova which is highly stable and linear while utilizing the advantages of a non-floating power supply.

**THE RESULT:** An extended frequency band width accurately supplied to the output stages of the amplifier.

## MOSFET Devices

HAFLER is one of the few manufacturers in the sound community to utilize MOSFET devices in both the power supply and output stages. **MOSFET** (**M**etal **O**xide **S**emiconductor **F**ield **E**ffect **T**ransistor) devices offer several important inherent advantages over the 30 year old technology of bi-polar design. These advantages include: thermal stability, fast switching speed, ultra low output impedance and wide bandwidth linearity. In addition, MOSFETs operate very similarly to vacuum tubes in that they are more linear than bipolar transistors. However, MOSFETs can deliver the midrange clarity without the limitations of transient response and high frequency phase shifting normally associated with tube operation.

**THE RESULT:** Thermal stability, fast switching speed, ultra low output impedance and wide bandwidth linearity.

## ◆ Subsonic Filter

The TRM series uses a Subsonic Filter to prevent the woofer from reproducing inaudible frequencies. Subsonic frequencies (known as infrasonic frequencies) are signals below the normal human hearing range and are generally considered to be below 20Hz. The subsonic filter reduces the energy of these frequencies and restrains the woofer from operating outside its optimum linear excursion. This type of electronic control eliminates the mechanical distortion caused by a woofer traveling beyond its XMAX, improves power handling, increases reliability and improves sonic performance.

**THE RESULT:** Improved power handling, increased reliability and improved sonic performance.

## ◆ Phase Control

The Phase Control is used to align the arrival time of the subwoofer's low frequency information with high frequency information produced by additional reference monitors. Aligning both signals will insure that both low and high frequencies arrive at the listening position at the same time. This eliminates the possibility of acoustical cancellation and improves the reproduction of transients.

**THE RESULT:** Eliminates phase cancellation and improves transient response.

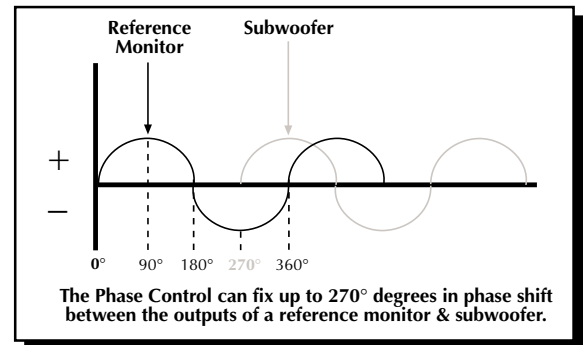

## Woofer

### ◆ Santoprene Rubber Surround

Santoprene is a very durable and temperature tolerant material which provides a consistent support necessary for the linear motion of the speaker cone. In addition, the damping capabilities eliminate the transmission of sonic disturbances between the cone and the frame of the speaker. This greatly improves the accuracy of the woofer's low frequency response.

**THE RESULT:** Improves woofer's low frequency response.

### ◆ Aluminum Voice Coil Former

The transducer's voice coil former is black anodized aluminum for highly efficient thermal transfer. Another method of producing voice coils is with Kapton® formers. Although this material is very resistant to heat, any heat generated by the transducer is "trapped" on the copper voice coil windings. HAFLEER uses aluminum voice coil formers because aluminum acts like a "heat sink" and helps dissipate heat away from the voice coil. This allows winding high temperature copper wire in multiple layers for improved efficiency.

**THE RESULT:** Improves power handling by efficiently dissipating heat.

# TRM10S

Front View

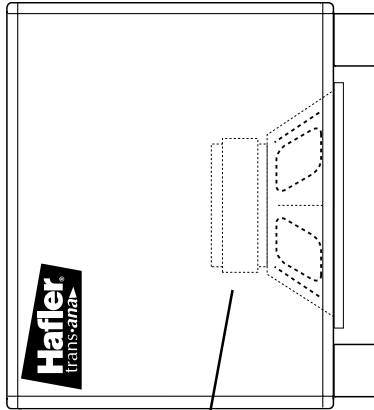

10" Subwoofer  
(located inside)

# TRM12S

Front View

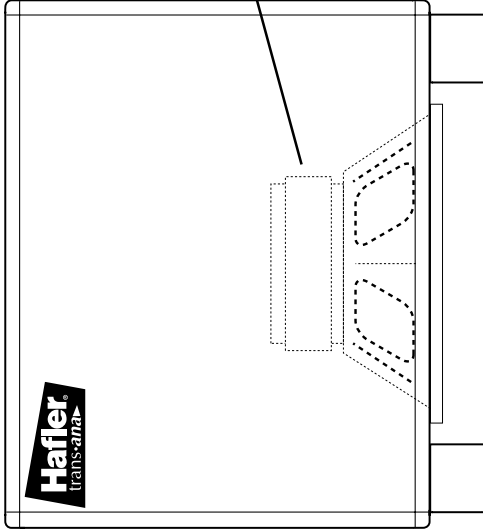

12" Subwoofer  
(located inside)

Rear View

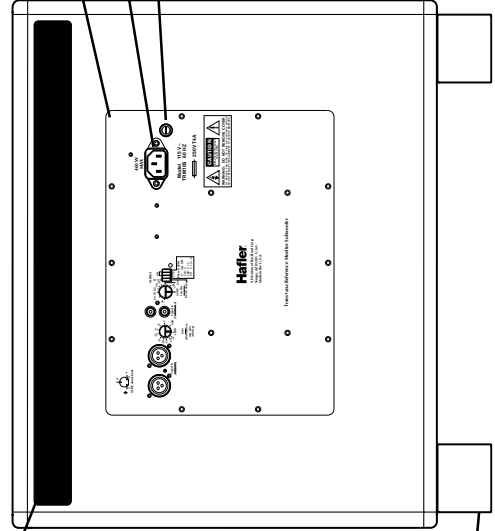

Heatsink  
AC Line Input  
AC Line Fuse

Rear View

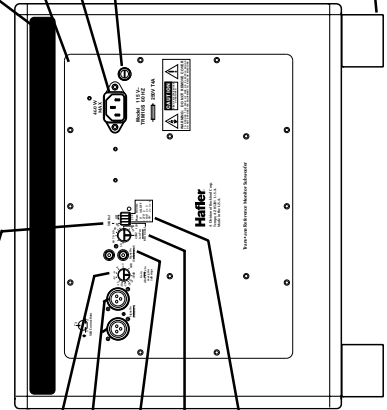

Port in Rear  
Heatsink  
AC Line Input  
AC Line Fuse  
Bal/Unbal Input Switch  
Input Sensitivity  
XLR Input  
RCA Input  
Low-Pass Crossover  
Phase Switch  
Feet

# SCHEMATIC DIAGRAM

NOTES: Unless specified otherwise

1. All resistors in ohms.
2. All capacitors in microfarads.

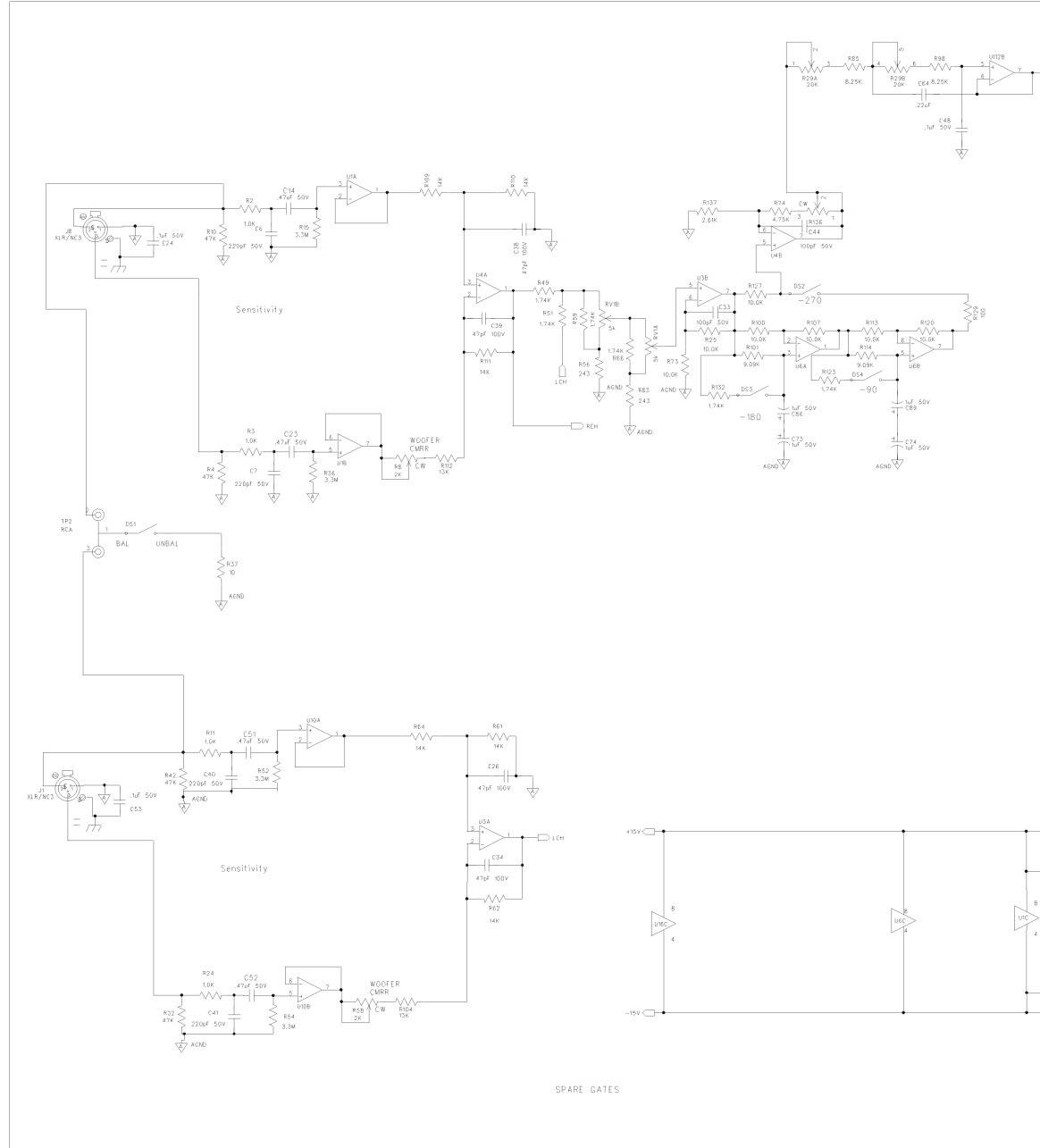

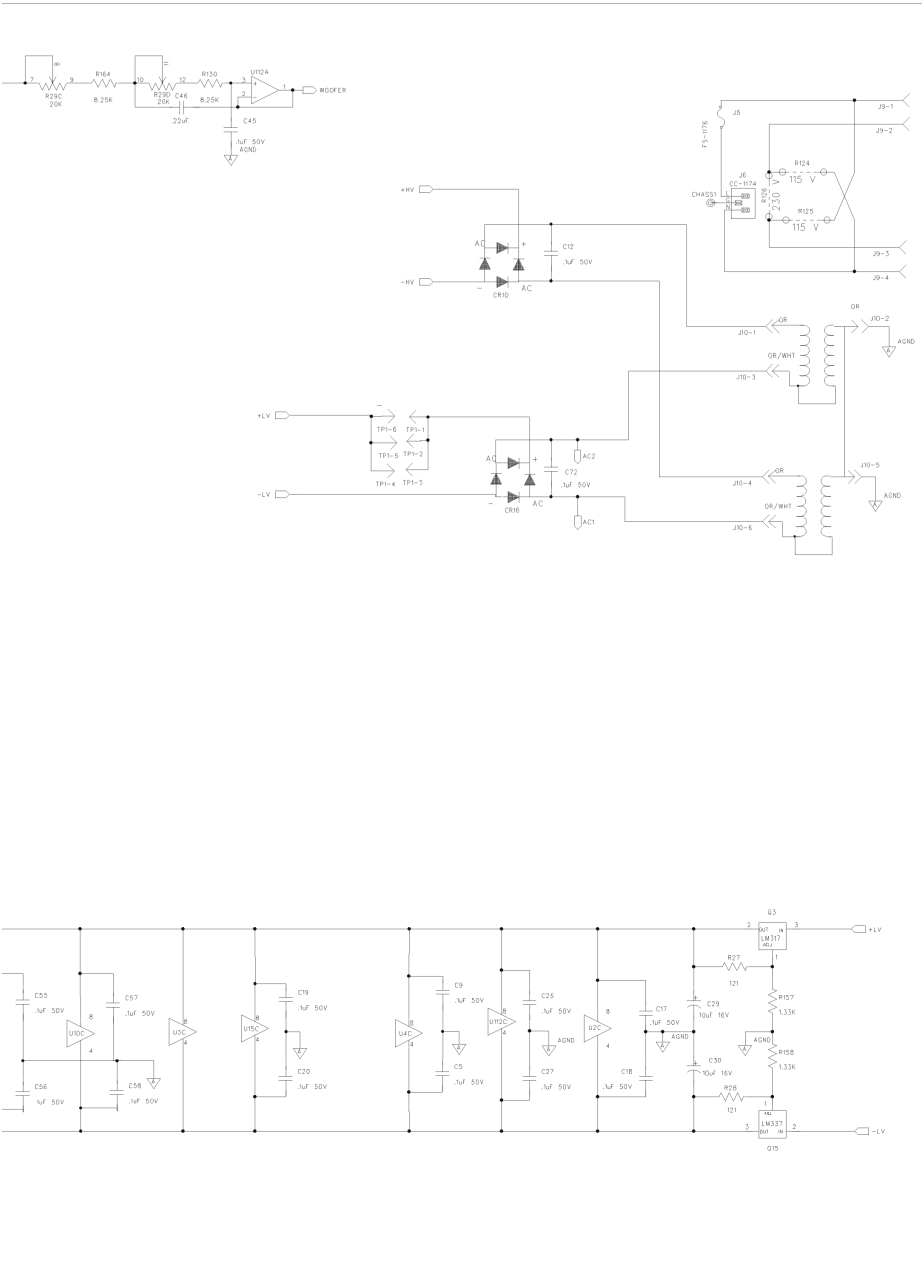

**Input Circuit / Power Supply Schematic**

# SCHEMATIC DIAGRAM

NOTES: Unless specified otherwise

1. All resistors in ohms.
2. All capacitors in microfarads.

NOTES: UNLESS SPECIFIED OTHERWISE

1. ALL RESISTORS IN OHMS.
2. ALL CAPACITORS IN MICROFARADS.
3. CHANNEL 1 ONLY SHOWN.

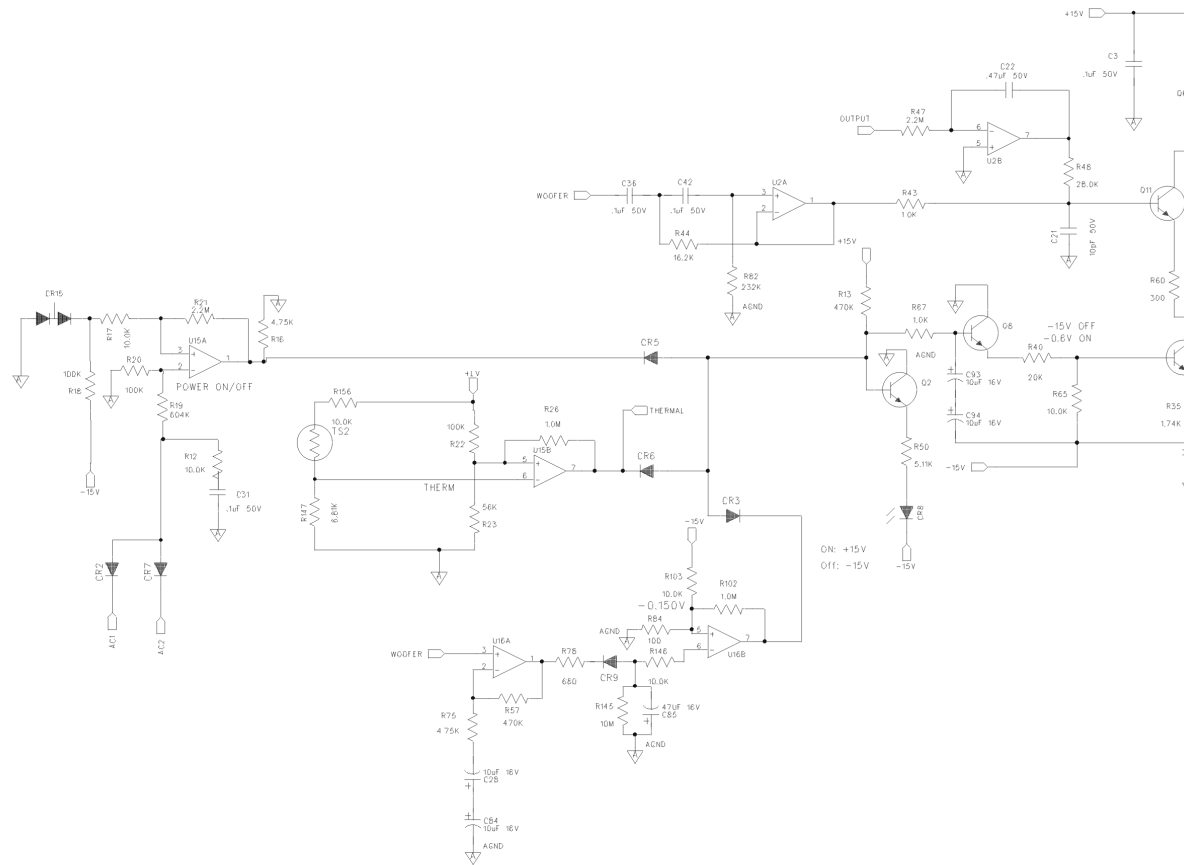





Qualified Service Personnel Only

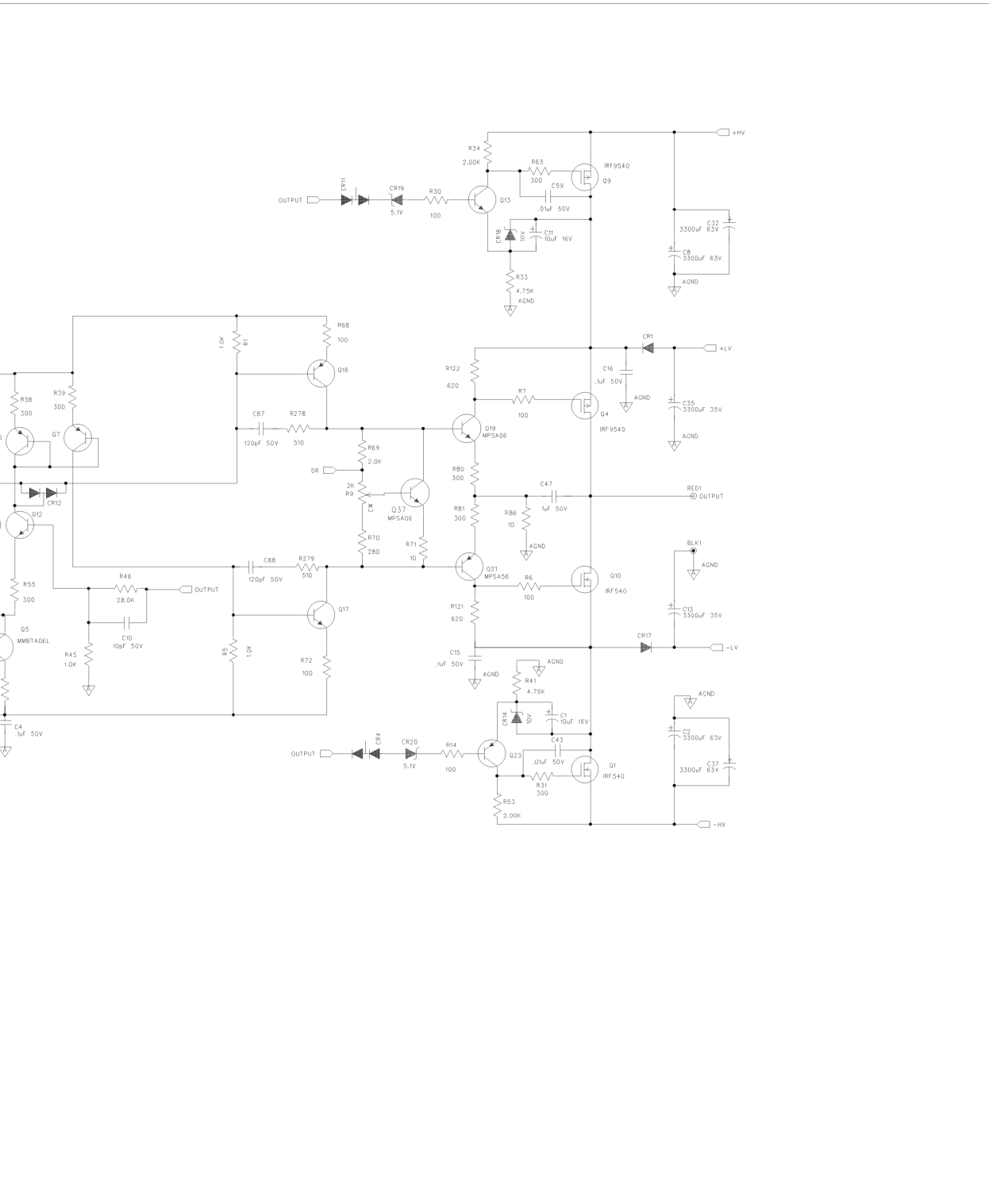

**Output Circuitry**

Removable Center Spread

# INSTALLATION

## LOCATION

The acoustic properties and size of the listening environment can drastically influence the *SPL* (Sound Pressure Level) and  $f^3$  (-3dB roll-off) of the subwoofer. However it's important to note that large or small acoustic spaces have little to no effect on the subwoofer cone excursion & box "Q." For the most part, we'll discuss the optimum location for two different installation methods: Studio Installation and Home Theater Installation.

### Studio Installations

In studio installations, damping material is usually used on the walls and ceilings make the room "acoustically dead." The main monitors are typically located 3' to 6' from the mixing console and therefore considered a near field (close field) application. In this type of anechoic environment, the subwoofer will tend to experience minimal "Boundary Loading" effects. For studio installations, HAFLER recommends experimenting with different locations within the studio that minimizes rattles or vibration of other equipment. You can fire the subwoofer downward (FIG. 1) or fire the subwoofer directly facing forward (FIG. 2). **In either application keep the subwoofer cabinet at least 5" (12.7 cm) away from any wall.**

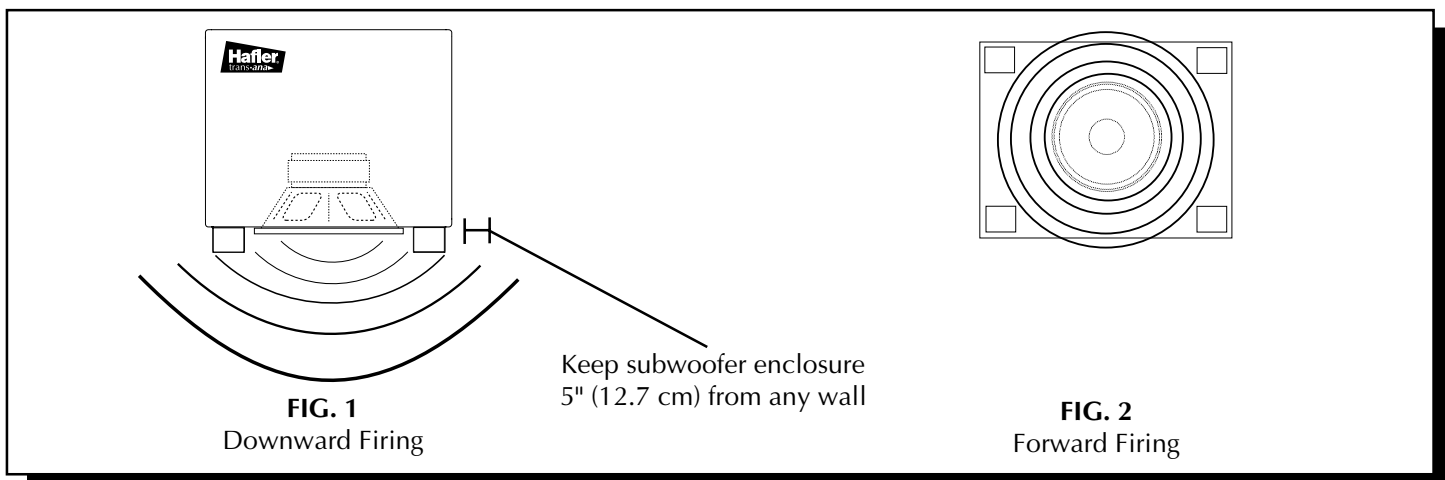

### Home Theater Installations

Home Theater installations are typically medium sized living rooms or game rooms that have large flat, uncovered walls. Acoustics in this type of installation can have a big effect on the *SPL* and  $f^3$  of the subwoofer because the walls are very reflective. The only elements in these installations that acoustically "absorb" sounds are furniture and carpet. Dramatic "Boundary Loading" can be achieved by locating the subwoofer under a table, next to a wall or in a corner (FIG. 4), thus increasing *SPL* and lowering the  $f^3$  of the subwoofer system. Locating the subwoofer in the middle of the room or in a large open area where there are few reflective surfaces will cause a decrease in *SPL* and an increase in  $f^3$ . Experiment with different locations in the room to determine which type of bass response works best in your home theater.

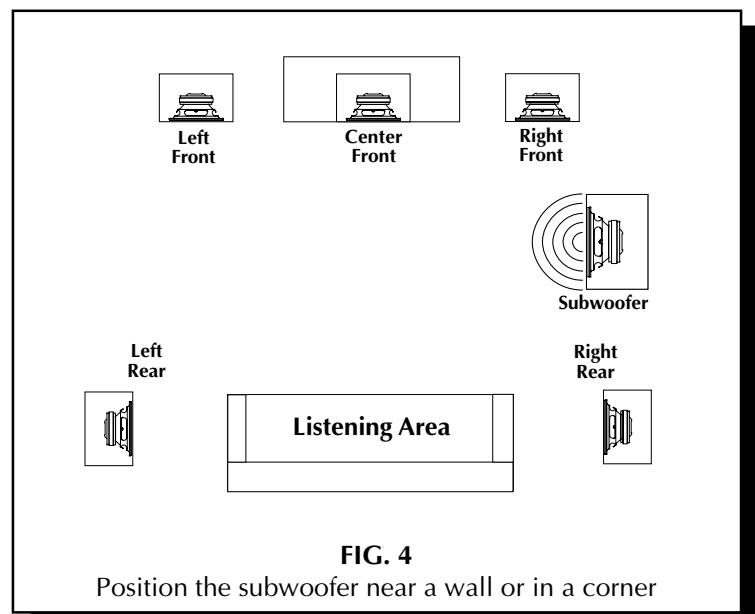

## INPUT SWITCH

The unbalanced input uses a conventional RCA phone jack. Move the input switch to RCA UNBALANCED to use this jack. The balanced input jack is an XLR plug. The XLR jack is connected according to the IEC and AES standard. Move the input switch to XLR BALANCED to use this jack.

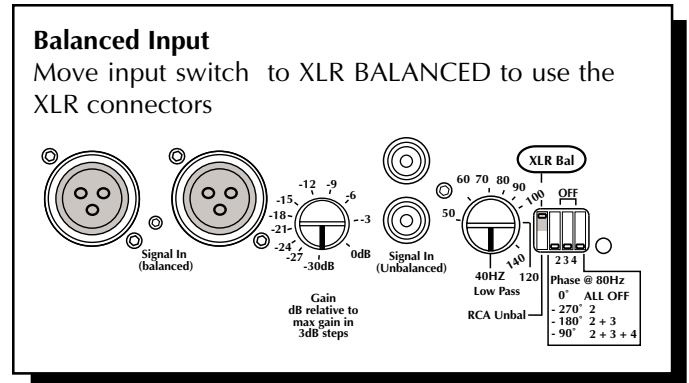
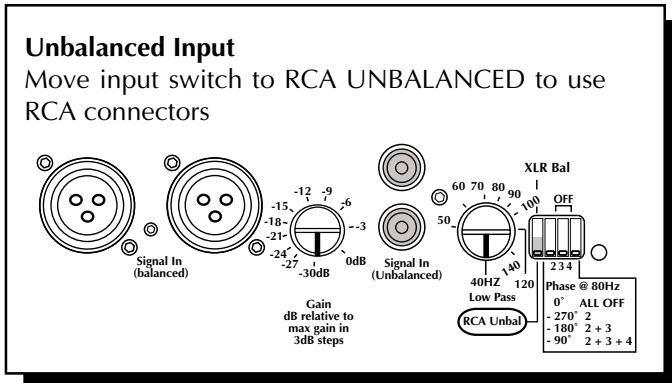

## XLR WIRING CONFIGURATIONS

Using the balanced XLR input is recommended for installations where long cable runs are used or when the potential for stray electromagnetic fields from other wires exists. There are balanced and unbalanced methods in which the XLR inputs can be used. The first method is an XLR Balanced Input using 3-conductor cable with signal carried on the first conductors, equal in amplitude and opposite in phase, and the third conductor being a ground "drain". In this configuration, noise common on both phases of the signal is effectively "canceled" out. The second method is an XLR Unbalanced Input using 2-conductor cable with the signal carried in the center conductor and the ground carried on the shield. Many popular mixers use unbalanced outputs and can be used with the XLR balanced input. However, in this type of configuration we recommend using twisted pair cable or short cable lengths to prevent residual ground noise.

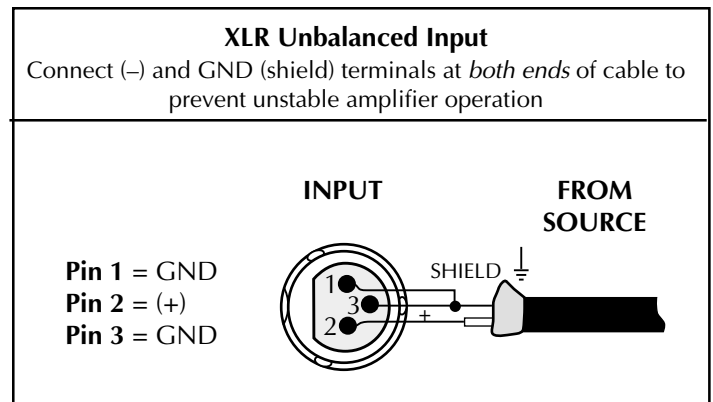
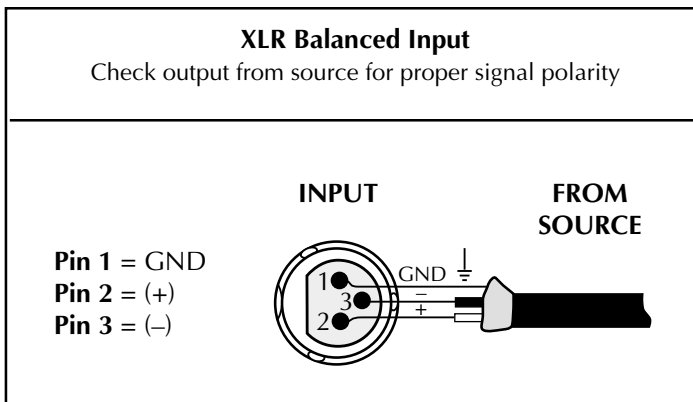

# OPERATION

## AUTO TURN-ON / SLEEP MODE

The TRM10s/TRM12s subwoofers automatically turn on when they sense an input signal. When the signal being fed to the TRM10s/TRM12s is turned off, the subwoofer's amplifier will turn off and go into "sleep mode." This feature eliminates the inconvenience of operating a mechanical switch.

## INPUT SENSITIVITY

The Input Sensitivity is used to match the TRM10s/TRM12s with signal levels from a variety of mixing consoles. The Input Sensitivity uses a potentiometer to match input levels over a 30dB range and is variable from +1dBu to -30dBu. The numbers listed on the back panel indicate the input in dBu required to produce an output of 100dB SPL @ 1 meter. When the control is set to its full CLOCKWISE position the monitor is matched to +1dB input level (the input circuit is less sensitive to the amplitude of the input signal). When the control is set to its full COUNTER CLOCKWISE position the monitor is matched to -30dB input level (the input circuit is more sensitive to the amplitude of the input signal).

## LOW-PASS CROSSOVER

The Low-Pass Crossover is used to set the electrical cutoff point of the subwoofer enclosure. The Crossover uses a variable potentiometer to set the cutoff point anywhere between 40Hz and 140Hz. When the control is set to its full CLOCKWISE position the cutoff frequency is set to 140Hz Low-Pass. When the control is set to its full COUNTER CLOCKWISE position the cutoff frequency is set to 40Hz Low-Pass.

It is important to match the Low-Pass crossover point of the subwoofer with the High-Pass crossover point of the high frequency reference monitors. Mismatching the crossover points can cause dips or peaks in the acoustical response. Overlapping the crossover points (i.e., subwoofer at 60Hz Low-Pass & high frequency monitors at 50Hz High-Pass) will cause a peak between 50Hz and 60Hz. Underlapping the crossover points (i.e., subwoofer at 40Hz Low-Pass & high frequency monitors at 70Hz High-Pass) will cause a dip between 40Hz and 70Hz.

*\*This graph was generated by setting the variable crossover to 40Hz, 50Hz, 60Hz, 70Hz, 80Hz, 90Hz, 100Hz, 120Hz & 140Hz.*

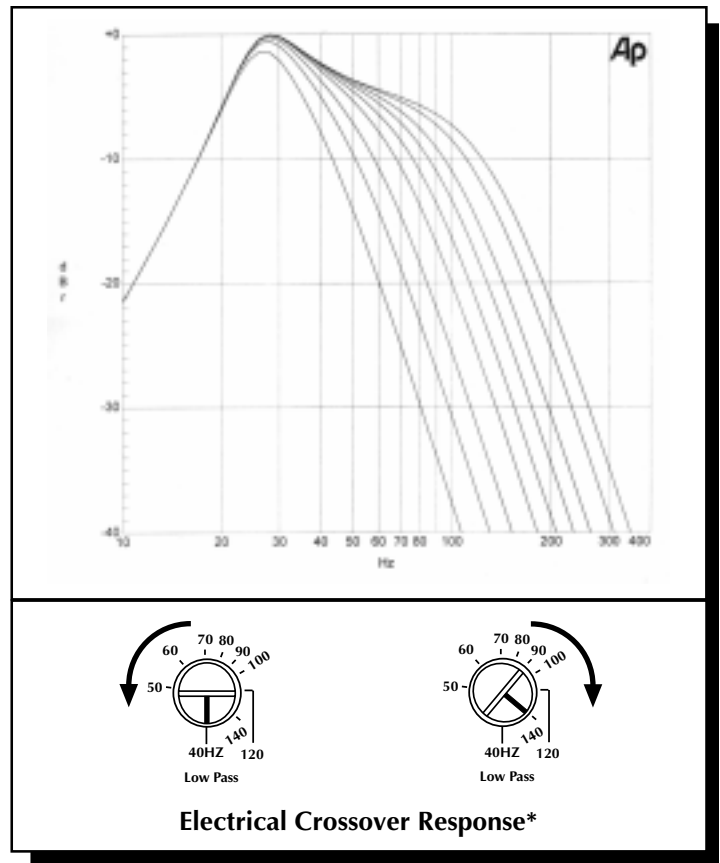

## PHASE CONTROL

The Phase Control switches allow the TRM10s/TRM12s to be acoustically aligned with other speakers in your system.  $0^\circ$ ,  $-90^\circ$ ,  $-180^\circ$ , or  $-270^\circ$  degrees of phase shift at 80Hz can be selected using DIP switches 2, 3, and 4. For  $0^\circ$  degrees of phase shift, leave all three switches in the OFF (up) position.  $-270^\circ$  degrees of phase shift occurs when switch 2 is selected in the ON (down) position.  $-180^\circ$  degrees can be achieved by selecting both switches 2 and 3 in the ON (down) position. Finally, selecting all switches 2, 3, and 4 in the ON (down) position produces  $-90^\circ$  degrees of phase shift.

### Setup Procedure

- 1) Place all your speakers and any acoustically significant components in their working location in the listening environment.
- 2) Insert a sine wave signal into the audio path. Be careful to turn down the level before turning on the amplifiers.
- 3) Choose a frequency that corresponds to the crossover frequency between the TRM10s/TRM12s and the full-range speakers.
- 4) From the listening position, alternate between the TRM10s/TRM12s and the full range speakers and adjust the levels until they have the same acoustic output. Use an SPL meter, a microphone on a VU meter, or your ears to accomplish this.
- 5) With all speakers on, try the  $0^\circ$ ,  $-270^\circ$ ,  $-180^\circ$ , and  $-90^\circ$  degree phase settings. The setting with the highest SPL reading from your listening position will produce the most effective acoustic alignment.
- 6) Set the TRM10s/TRM12s gain control according to your preference. This will not affect the acoustic alignment of your system.

Here is a list of some items that can affect acoustic alignment: Relocating speakers, changing the TRM10s/TRM12s Low Pass frequency, changing the acoustic environment (i.e., traps, diffusors, etc.), changing the listening position.

Although this procedure produces the maximum achievable acoustic gain for your system, listening tests may still lead you to prefer another setup.

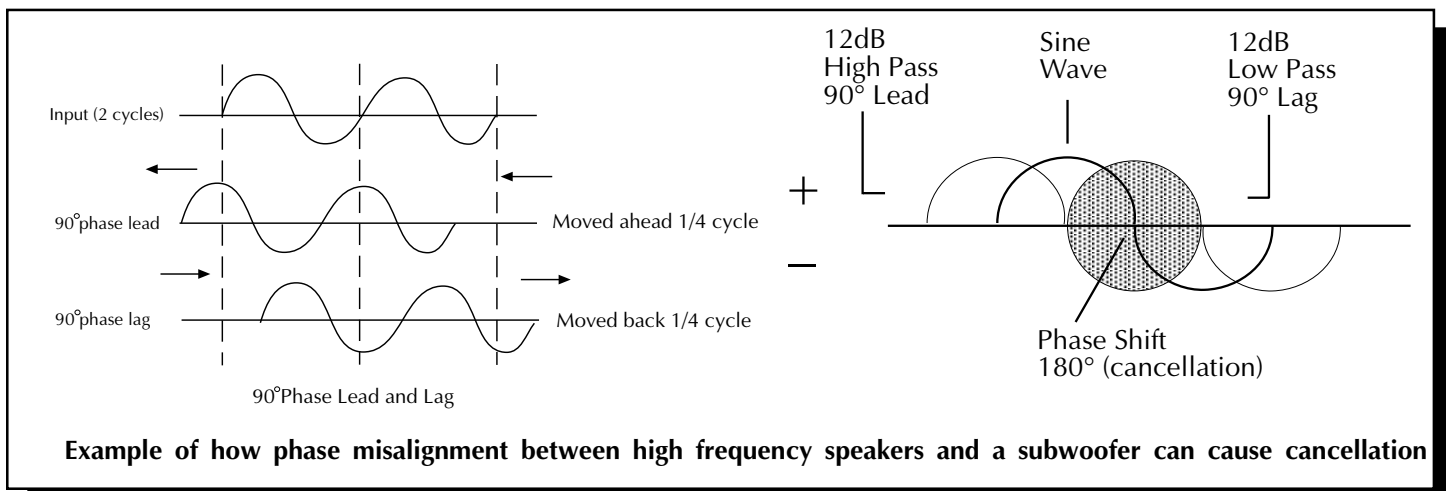

## AC LINE

The TRM10s/TRM12s operate from a 115 VAC/60Hz power line. The TRM10sCE/TRM12sCE operate from a 230 VAC 50/60Hz power line. Connection is made by a 16 gauge, IEC Type 320, grounded line cord. For safety considerations only a properly grounded (earthed) receptacle should be used. If a grounded circuit is not available, do not break off the ground pin; use the proper adapter plug for a two wire receptacle with the grounding plug suitably connected to earth ground.



**IMPORTANT: The power line fuse is mounted on the rear panel. If this fuse blows, replace it only with the same type and rating as indicated in the parts list.**

## LED INDICATOR

Amplifier operation is monitored internally and has a status LED. This indicator can be used for system troubleshooting. The LED will illuminate GREEN if signal is present at the subwoofer's input. The LED will turn off and the amplifier will go into sleep mode if signal is not present.

COLOR	STATUS
GREEN	Power on
NO LED	Sleep Mode

## BREAK-IN and WARM-UP

We recommend initially breaking in the subwoofer for approximately 8 hours with musical information to establish the monitor's natural bass response. To achieve the best sonic performance and image stability from the internal amplifier, we recommend letting it warm up for 1 hour before beginning any critical listening.

## CLEANING & MAINTENANCE

There is no requirement for regular maintenance on the electronic components of the monitor. If the cabinet or woofer becomes soiled, it can be cleaned using a damp, soft cloth. If the monitor is located in a particularly dusty environment, cleaning the inside with compressed air or vacuuming every 18 to 24 months is sufficient.



# PARTS LIST

## DESIGNATOR VALUE

ALL RESISTORS IN OHMS

DESIGNATOR	VALUE	PART #		
R1	1.0K OHM 1/10W 1%	RM/10-1001B	R42	47K OHM 1/10W 5%
R10	47K OHM 1/10W 5%	RM/10-473B	R43	1.0K OHM 1/10W 1%
R100	10K OHM 1/10W 1%	RM/10-1002B	R44	16.2K OHM 1/10W 1%
R101	9.09KOHM 1/10W 1%	RM/10-9091B	R45	1.0K OHM 1/10W 1%
R102	1M OHM 1/10W 5%	RM/10-105B	R46	RES 28K OHM 1/4W 1%
R103	10K OHM 1/10W 1%	RM/10-1002B	R47	2.2M OHM 1/10W 5%
R104	13K OHM 1/10W 5%	RM/10-133B	R48	28K OHM 1/10W 1%
R107	10K OHM 1/10W 1%	RM/10-1002B	R49	1.74K OHM 1/10W 1%
R109	14K OHM 1/10W 1%	RM/10-1402B	R5	1.0K OHM 1/10W 1%
R11	1.0K OHM 1/10W 1%	RM/10-1001B	R50	5.11K OHM 1/4W 1%
R110	14K OHM 1/10W 1%	RM/10-1402B	R51	1.74K OHM 1/10W 1%
R111	14K OHM 1/10W 1%	RM/10-1402B	R52	3.3M OHM 1/10W 5%
R112	13K OHM 1/10W 5%	RM/10-133B	R53	2K OHM 1/4W 1%
R113	10K OHM 1/10W 1%	RM/10-1002B	R54	3.3M OHM 1/10W 5%
R114	9.09KOHM 1/10W 1%	RM/10-9091B	R55	300 OHM 1/10W 5%
R12	10K OHM 1/10W 1%	RM/10-1002B	R56	243 OHM 1/4W 1%
R120	10K OHM 1/10W 1%	RM/10-1002B	R57	470K OHM 1/10W 5%
R121	620 OHM 1/10W 5%	RM/10-621B	R58	POT 2K TRIM
R122	620 OHM 1/10W 5%	RM/10-621B	R59	1.74K OHM 1/10W 1%
R123	1.74K OHM 1/10W 1%	RM/10-1741B	R6	100 OHM 1/10W 5%
R124	RES 0 OHM 1/4W	RMP/4-0000-03	R60	300 OHM 1/10W 5%
R125	RES 0 OHM 1/4W	RMP/4-0000-03	R61	14K OHM 1/10W 1%
R127	10K OHM 1/10W 1%	RM/10-1002B	R62	14K OHM 1/10W 1%
R129	100 OHM 1/10W 5%	RM/10-101B	R63	300 OHM 1/10W 5%
R13	470K OHM 1/10W 5%	RM/10-474B	R64	14K OHM 1/10W 1%
R130	8.25K OHM 1/10W 1%	RM/10-8251B	R65	10K OHM 1/10W 1%
R132	1.74K OHM 1/10W 1%	RM/10-1741B	R66	1.74K OHM 1/10W 1%
R136	POT 5K	RV-502Q	R67	1.0K OHM 1/10W 1%
R137	2.61K OHM 1/10W 1%	RM/10-2611B	R68	100 OHM 1/4W 5%
R14	100 OHM 1/4W 5%	RM/4-101C	R69	2.0K OHM 1/10W 1%
R145	10M OHM 1/10W 5%	RM/10-106B	R7	100 OHM 1/10W 5%
R146	10K OHM 1/10W 1%	RM/10-1002B	R70	280 OHM 1/10W 1%
R147	6.81K OHM 1/10W 1%	RM/10-6811B	R71	10 OHM 1/10W 5%
R15	3.3M OHM 1/10W 5%	RM/10-335B	R72	100 OHM 1/4W 5%
R156	10K OHM 1/10W 1%	RM/10-1002B	R73	10K OHM 1/10W 1%
R157	1.33K OHM 1/4W 1%	RM/4-1331C	R74	4.75K OHM 1/10W 1%
R158	1.33K OHM 1/4W 1%	RM/4-1331C	R75	4.75K OHM 1/10W 1%
R16	4.75K OHM 1/10W 1%	RM/10-4751B	R78	680 OHM 1/10W 5%
R164	8.25K OHM 1/10W 1%	RM/10-8251B	R8	POT 2K TRIM
R17	10K OHM 1/10W 1%	RM/10-1002B	R80	300 OHM 1/10W 5%
R18	100K OHM 1/10W 5%	RM/10-104B	R81	300 OHM 1/10W 5%
R19	604K OHM 1/10W 1%	RM/10-6043B	R82	232K OHM 1/10W 1%
R2	1.0K OHM 1/10W 1%	RM/10-1001B	R83	243 OHM 1/4W 1%
R20	100K OHM 1/10W 5%	RM/10-104B	R84	100 OHM 1/10W 5%
R21	2.2M OHM 1/10W 5%	RM/10-225B	R85	8.25K OHM 1/10W 1%
R22	100K OHM 1/10W 5%	RM/10-104B	R86	RES 10 OHM 1W
R23	56K OHM 1/10W 5%	RM/10-563B	R9	POT 2K TRIM
R24	1.0K OHM 1/10W 1%	RM/10-1001B	R98	8.25K OHM 1/10W 1%
R25	10K OHM 1/10W 1%	RM/10-1002B	RV1	KNOB 2-3 WAY CROSSOVER
R26	1M OHM 1/10W 5%	RM/10-105B	RV1	DUAL 5K LINEAR
R27	121 OHM 1/10W 1%	RM/10-1210B	C1	10UF 16V
R278	510 OHM 1/10W 5%	RM/10-511B	C10	10PF 50V
R28	121 OHM 1/10W 1%	RM/10-1210B	C11	10UF 16V
R29	KNOB 2-3 WAY CROSSOVER	KN-1824-A	C12	.1UF 50V
R29	POT QUAD 9MM 20K	RV-203Q	C13	CAP 3300UF 35V
R3	1.0K OHM 1/10W 1%	RM/10-1001B	C14	.47UF 50V
R30	100 OHM 1/4W 5%	RM/4-101C	C15	.1UF 50V
R31	300 OHM 1/10W 5%	RM/10-301B	C16	.1UF 50V
R32	47K OHM 1/10W 5%	RM/10-473B	C17	.1UF 50V
R33	4.75K OHM 1/4W 1%	RM/4-4751C	C18	.1UF 50V
R34	2K OHM 1/4W 1%	RM/4-2001C	C19	.1UF 50V
R35	820 OHM 1/4W 5%	RM/4-821C	C2	CAP 3300UF 63V
R36	3.3M OHM 1/10W 5%	RM/10-335B	C20	.1UF 50V
R37	10 OHM 1/10W 5%	RM/10-100B	C21	10PF 50V
R38	300 OHM 1/10W 5%	RM/10-301B	C22	.47UF 50V
R39	300 OHM 1/10W 5%	RM/10-301B	C23	.47UF 50V
R4	47K OHM 1/10W 5%	RM/10-473B	C24	.1UF 50V
R40	20.0K OHM 1/10W 1%	RM/10-2002B	C25	.1UF 50V
R41	4.75K OHM 1/4W 1%	RM/4-4751C	C26	47PF 100V
			C27	.1UF 50V
			C28	10UF 16V
				RM/10-473B
				RM/10-1001B
				RM/10-1622B
				RM/10-1001B
				RMP/4-2802-04
				RM/10-225B
				RM/10-2802B
				RM/10-1741B
				RM/10-1001B
				RM/4-5111C
				RM/10-1741B
				RM/10-335B
				RM/4-2001C
				RM/10-335B
				RM/10-301B
				RM/4-2430C
				RM/10-474B
				RV-202
				RM/10-1741B
				RM/10-101B
				RM/10-301B
				RM/10-1402B
				RM/10-1402B
				RM/10-301B
				RM/10-1402B
				RM/10-1002B
				RM/10-1741B
				RM/10-1001B
				RM/4-101C
				RM/10-2001B
				RM/10-101B
				RM/10-2800B
				RM/10-100B
				RM/4-101C
				RM/10-1002B
				RM/10-4751B
				RM/10-4751B
				RM/10-681B
				RV-202
				RM/10-301B
				RM/10-301B
				RM/10-2323B
				RM/4-2430C
				RM/10-101B
				RM/10-8251B
				RM1-100-012
				RV-202
				RM/10-8251B
				KN-1824-A
				RV-502DPA
				CER-106SM
				CDS-100CAAA
				CER-106SM
				CYV-104
				CERS-338B
				CYV-474
				CDS-104CBBB
				CDS-104CBBB
				CDS-104CBBB
				CDS-104CBBB
				CDS-104CBBB
				CERS-338E
				CDS-104CBBB
				CDS-100CAAA
				CYV-474
				CYV-474
				CDS-104CBBB
				CDS-104CBBB
				CDS-470DAAA
				CDS-104CBBB
				CER-106SM



C29	10UF 16V	CER-106SM	Q19	XSTR NPN MPSA06	SS-102A	
C3	.1UF 50V	CYV-104	Q2	XSTR MMBT3904LT1 NPN	SS-0792	
C30	10UF 16V	CER-106SM	Q2	Regulator LM317	WP-2350	
C31	.1UF 50V	CDS-104CBBB	Q21	XSTR MPS-A56	SS-101A	
C32	CAP 3300UF 63V	CERS-338E	Q23	XSTR MMBT3906LT1 PNP	SS-0791	
C33	100PF 50V	CDS-101CAAA	Q3	Regulator LM337	WP-2348	
C34	47PF 100V	CDS-470DAAA	Q37	XSTR MPS6521	SS-209	
C35	CAP 3300UF 35V	CERS-338B	Q5	XSTR MMBTA06L	SS-102SM	
C36	.1UF 50V	CYV-104	Q6	XSTR MMBT3906LT1 PNP	SS-0791	
C37	CAP 3300UF 63V	CERS-338E	Q7	XSTR MMBT3906LT1 PNP	SS-0791	
C38	47PF 100V	CDS-470DAAA	Q8	XSTR MMBT3904LT1 NPN	SS-0792	
C39	47PF 100V	CDS-470DAAA	U1	OPAMP TL072CD	SS-143SM	
C4	.1UF 50V	CYV-104	U10	OPAMP TL072CD	SS-143SM	
C40	220PF 50V	CDS-221CAAA	U16	OPAMP TL072CD	SS-143SM	
C41	220PF 50V	CDS-221CAAA	U2	OPAMP TL072CD	SS-143SM	
C42	.1UF 50V	CYV-104	U112	OPAMP DUAL LM833D	SS-187SM	
C43	.01UF 50V	CDS-103CBBB	U3	OPAMP DUAL LM833D	SS-187SM	
C44	100PF 50V	CDS-101CAAA	U4	OPAMP DUAL LM833D	SS-187SM	
C45	.1UF 50V	CYV-104	U6	OPAMP DUAL LM833D	SS-187SM	
C46	.22UF 50V	CYV-224	U15	COMPTR DUAL LM393D	SS-207SM	
C47	.1UF 50V	CYV-104	J6	CONN IEC POWER INLET	CC-1174	
C48	.1UF 50V	CYV-104	J1	CONN XLR NEUTRIK NC3FAH-2-0	CC-2339	
C5	.1UF 50V	CDS-104CBBB	J8	CONN XLR NEUTRIK NC3FAH-2-0	CC-2339	
C51	.47UF 50V	CYV-474	J9	HEADER 4 SOCKET	CC-2352	
C52	.47UF 50V	CYV-474	J10	HEADER 6 SOCKET	CC-2353	
C53	.1UF 50V	CDS-104CBBB	J5	4 AMP 3AG SLO-BLO FUSE	FS-004SB	⚠
C55	.1UF 50V	CDS-104CBBB	J5	FUSE HOLDER CAP 3AG	FS-1175	⚠
C56	.1UF 50V	CDS-104CBBB	J5	FUSE HOLDER BODY PC MOUNT	FS-1176	⚠
C57	.1UF 50V	CDS-104CBBB	TP1	SH 2X3 JUMPER	CC-648	
C58	.1UF 50V	CDS-104CBBB	TP1	HDR 6 PIN DUAL ROW	CC-673	
C59	.01UF 50V	CDS-103CBBB	TP2	RCA JACK GOLD TWIN	CCH-228	
C6	220PF 50V	CDS-221CAAA	TS2	THERMISTOR 10K EPOXY	SS-0426-066	⚠
C64	.22UF 50V	CYV-224	CHASS1	HARNESS P1000 CHASSIS GND	FA-1401-A	⚠
C7	220PF 50V	CDS-221CAAA	DS1	4 POS DIP SWITCH	SW-1649	
C72	.1UF 50V	CYV-104		Transformer	TT-2327-D	⚠
C73	1UF 50V	CER-105CSM		IEC Linecord	WIR9856	⚠
C74	1UF 50V	CER-105CSM		10" Woofer	FG26388WP	⚠
C8	CAP 3300UF 63V	CERS-338E		12" Woofer	FG26394WP	⚠
C84	10UF 16V	CER-106SM		Plastic Foot	SHW10459	
C85	47UF 16V	CER-476SM		Neoprene Pad	HDW10441	
C86	1UF 50V	CER-105CSM		1/4"-20x2" Phillips Screw	HDW10460	
C87	120PF 50V	CDS-121CAAA				
C88	120PF 50V	CDS-121CAAA				
C89	1UF 50V	CER-105CSM				
C9	.1UF 50V	CDS-104CBBB				
C93	10UF 16V	CER-106SM				
C94	10UF 16V	CER-106SM				
CR1	DIO BYV 28-150	SS-176-059				
CR10	BRIDGE RECTIFIER 8A	SS-0799-068	⚠			
CR11	DIO DUAL BAV99L	SS-260SM				
CR12	DIO DUAL BAV99L	SS-260SM				
CR14	DIO ZENER MMBZ5240BL	SS-1052				
CR15	DIO DUAL BAV99L	SS-260SM				
CR16	BRIDGE RECTIFIER 8A	SS-0799-068	⚠			
CR17	DIO BYV 28-150	SS-176-059				
CR18	DIO ZENER MMBZ5240BL	SS-1052				
CR19	DIODE ZENER					
	MMBZ5231BLT1	SS-0775				
CR2	DIO MMBD914L	SS-803SM				
CR20	DIODE ZENER					
	MMBZ5231BLT1	SS-0775				
CR3	DIO MMBD914L	SS-803SM				
CR4	DIO DUAL BAV99L	SS-260SM				
CR5	DIO MMBD914L	SS-803SM				
CR6	DIO MMBD914L	SS-803SM				
CR7	DIO MMBD914L	SS-803SM				
CR8	GREEN LED	SS-2428-054				
CR9	DIO MMBD914L	SS-803SM				
Q11	XSTR MMBT5088L NPN	SS-0114				
Q12	XSTR MMBT5088L NPN	SS-0114				
Q13	XSTR MMBT3904LT1 NPN	SS-0792				
Q17	XSTR MMBT3904LT1 NPN	SS-0792				
Q18	XSTR MMBT3906LT1 PNP	SS-0791				

MODEL TRM10sCE/TRM12sCE 230V Differences			
	European Linecord <HAR>	WIR10138	⚠
J5	Fuse Holder Cap	5X20mmFS-1269-A	⚠
J5	1.25A SLO-BLO Fuse	FS-1474-A	⚠
R126	RES 0 OHM 1/4W	RMP/4-0000	⚠

⚠ Components marked with this symbol are safety critical and should only be replaced with identical components.

⚠ Los componentes marcados con el simbolo son imprescindibles para la proteccion del equipo, por lo cual que solo sean reemplazados por los mismos componentes.

⚠ Les composants marqués du symbole sont indispensables à la sécurité et ne peuvent être remplacés qu'avec des composants identiques.

⚠ Bauteile, die mit einem gekennzeichnet sind, sind sehr wichtig und dürfen nur mit den original Ersatzteilen ausgetauscht werden.

⚠ I componenti contrassegnati da sono critici per la sicurezza e devono essere rimpiazzati solo con ricambi di valore identico.

# TRM10s/12s FUNCTIONAL BLOCK DIAGRAMS

 **Qualified Service Personnel Only**

## Input circuit

The stereo input signals are connected to the amplifier through balanced XLR connectors J8 and J1, or unbalanced RCA connector TP2. Unbalanced operation can be selected with switch DS1, which grounds the RCA shell through R37. Input buffers U1 and U10 provide a stable input impedance, dominated by R10, R4, R42, and R32. The left and right balanced summing amplifiers U4A and U3A sum the inverting and non-inverting signals to form unbalanced right and left channel outputs RCH and LCH. The Common Mode Rejection Ratio (CMRR) of each channel is optimized with trimpots R8 and R58.

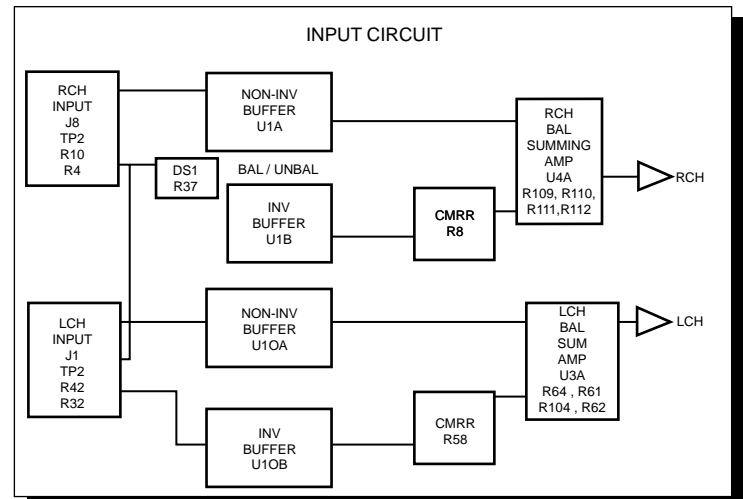

## Mono Sum/Gain Circuit

Left and right input signals LCH and RCH are summed to mono through R49 and R51. The mono signal is then attenuated in two stages with dual potentiometer RV1 which is accessible from the rear panel heatsink and serves as the gain control. R56 and R83 determine the maximum achievable attenuation level. R59 and R66 help to reduce the tracking errors of RV1 due to absolute resistance. Buffer U3B unloads the attenuators and provides 6dB of gain with R25 and R73.

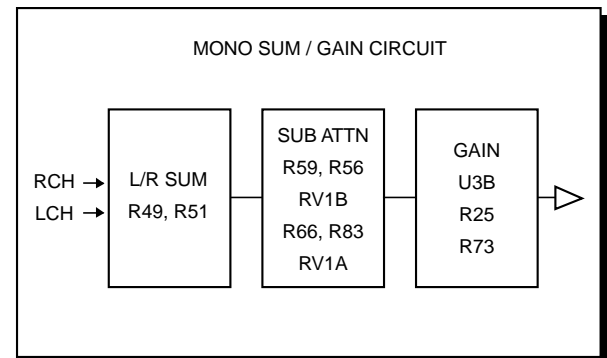

## Phase Control Circuit

The output signal of U3B goes directly to U4B if DS2 is left open (0 degrees phase shift). If only DS2 is closed, the signal goes through 2 cascaded phase shift stages built around U6A and U6B, and experiences a 270 degree phase shift. Additionally closing DS3 causes the phase shift to be 180 degrees. Adding another closed switch DS4 results in only 90 degrees of phase shift. DS2, DS3, and DS4 are labeled 2,3, and 4 respectively on the rear panel heatsink.

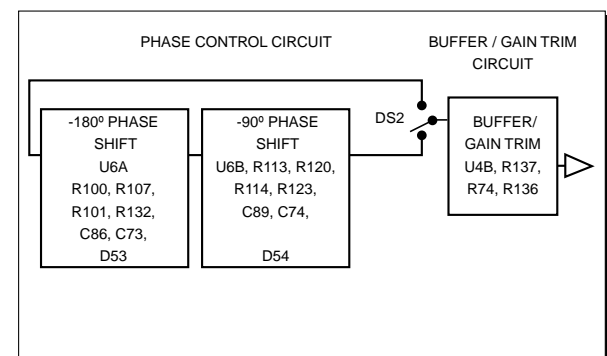

## Buffer/Gain Trim Circuit

U4B works as a buffer, and as a factory gain trim using trimpot R136. The voltage gain of the stage is  $(R74+R136)/R137$ .

## Filter Circuits

TU112A and U112B form two cascaded 2nd order variable low pass crossover filters, for an overall 4th order 24dB/octave Linkwitz-Riley response. The quad potentiometer R29 is accessible from the rear panel heatsink and indicates the 40Hz to 140Hz range of the variable Low-Pass crossover. Following these circuits is a 2nd order subsonic High-Pass filter at U2A. The signal then connects to the Class-G amplifier.

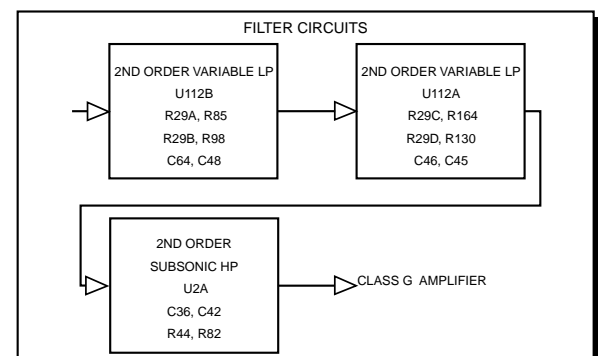

### Class-G Trans•ana Amplifier

The transistor Q8 is configured as a switch, which controls the current source Q5, of the input differential amplifier Q11 and Q12. If the power On/Off, Signal Sensing, and Thermal Protection circuits have all stopped pulling to -15V, the turn-on process begins, and the voltage at the emitter of Q8 slowly ramps up to zero Volts according to the charging time of soft start components R13, C93, and C94. 15V is divided between R40 and R65, and imposed across the base-emitter of Q5 and R35, causing current source Q5 to turn the amplifier on.

The input signal is connected across the differential amp transistors Q11 and Q12. U2B is configured as a DC-servo integrator to null any DC at the output.

The output of the differential amplifier is fed to the positive pre-driver Q18,

and to the current mirror which mirrors the inverted input current of Q6 into Q7 and delivers it to the negative pre-driver Q17. The pre-driver current is split between the three current paths of the bias and the driver circuit according to the factory bias setting of trimpot R9, and the temperature of Q37. Q37 is thermally linked to the heatsink, and compensates for the gate-voltage temperature coefficient of the output MOSFETs. Q19 drives the positive output MOSFET Q4, and Q21 drives the negative output MOSFET Q10. Local feedback components C47 and R86 help to stabilize this output stage.

At low output voltages, current flows to the woofer from the lower voltage rail +LV or -LV through the diodes CR1/CR17 and output MOSFETs Q4/Q10. When the output voltage approaches or exceeds these lower voltage rails, output current flows from the higher voltage rail +HV or -HV through CLASS-G MOSFET Q9/Q1 and output MOSFETS Q4/Q10.

Positive G driver Q13 turns on class G MOSFET Q9 when the base-emitter voltage exceeds 0.7V. This occurs when  $(OUT - 1.4 - 5.1V) - (+LV - 0.7 - 10) > 0.7V$ , which reduces to  $OUT > +LV - 3.5V$ . A similar equation can be applied to the negative class G driver Q23. The resulting behavior can be observed as the class G rail on the source of the output MOSFET tracking 3.5V higher (or lower) than the output signal.

### Soft Start Circuit

The amplifier soft start circuit is controlled by three On/Off circuits: Power On/Off, Signal Sensing, and Thermal Protection. The "diode OR" connection of CR5, CR6, and CR3 causes the amplifier to turn off if power On/Off is low or Signal Sensing is low or the Thermal Protection is low. The amplifier will turn on only if all these circuit outputs are high. In this all-high condition, CR5, CR6, and CR3 are open circuited or back-biased, allowing R13 to turn on Q2 and Q8, illuminating LED CR8 and turning on the amplifier. Q8 is turned on slowly, according to the time constant of R13 and C93 and C94. This "soft start" behavior eliminates audible turn on transients.

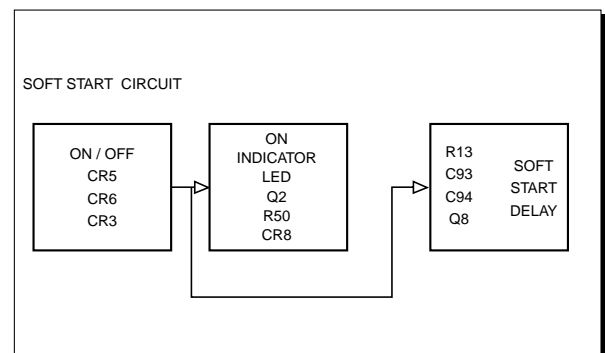
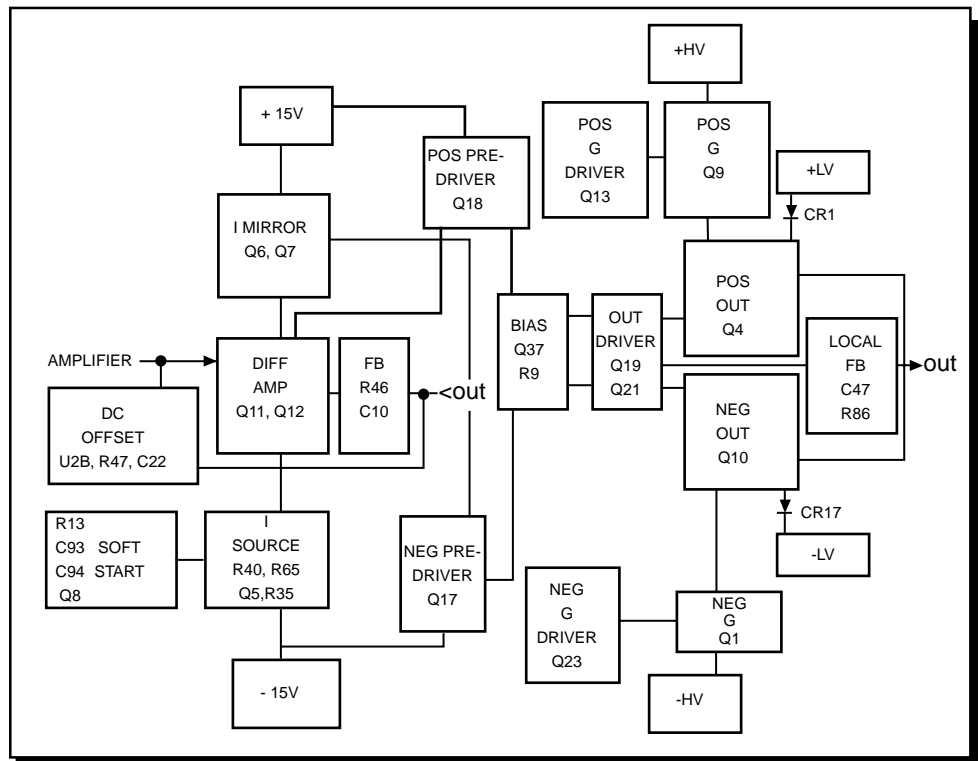

**Power On/Off Circuit**

The power on/off circuit is designed to turn the amplifier on slowly and off quickly. When AC power is initially applied to the subwoofer, AC signals on the secondary of the power transformer are negatively rectified through CR2 and CR7 into peak holding capacitor C31, and divided by R19 and R20. When the resulting DC voltage at pin 2 of U15A is lower than the reference voltage of -1.4 at pin 3, the output of U15 goes high, allowing the soft start circuitry to slowly turn on the amplifier. When AC power is removed from the subwoofer, pin 2 very quickly goes toward 0V and flips U15A low to -15V, immediately turning the amplifier off before the power supplies collapse.

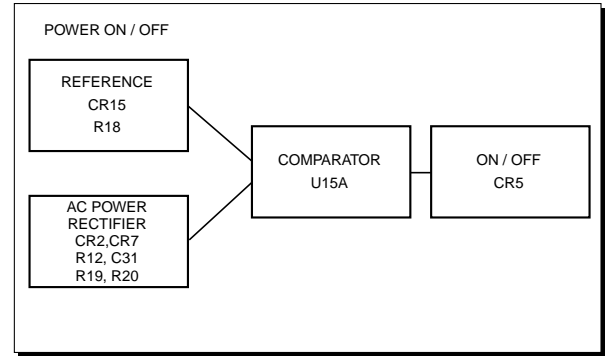

**Signal Sensing Turn-On Circuit**

The amplifier will not turn on until an input signal is detected. The first stage of the detection circuit amplifies the WOOFER signal by 40dB - to insure that even the smallest input signal is detected - and high pass filters it to eliminate DC offset errors. This amplified signal is negatively rectified by CR9 and held by C85. When the voltage at pin 6 of U16B goes lower than the -0.15V reference at pin 5, the output goes high, allowing the soft start circuitry to turn the amplifier on. After signal is removed, the 470-second time constant of C85 and R145 will discharge slowly towards 0V until it is higher than -0.15V, causing U16B to go low to -15V, turning the amplifier off.

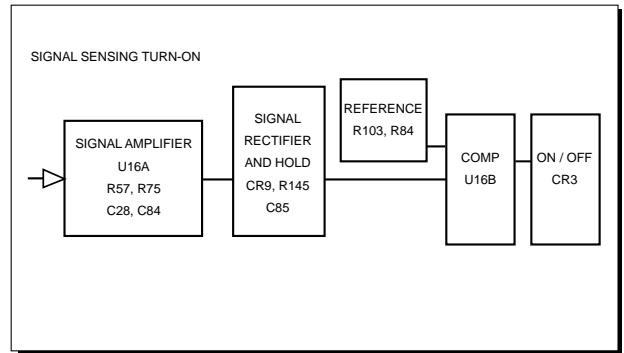

**Thermal Protection**

The thermal protection turns off the amplifier when the heatsink reaches an excessively high temperature. This condition is detected by the NTC (Negative Temperature Coefficient) thermistor TS2. At higher temperatures, TS2 has a lower resistance - causing a higher voltage at pin 6 of U15B. When this voltage exceeds the reference voltage at pin 5, the output of U15B goes low to -15V and turns the amplifier off.

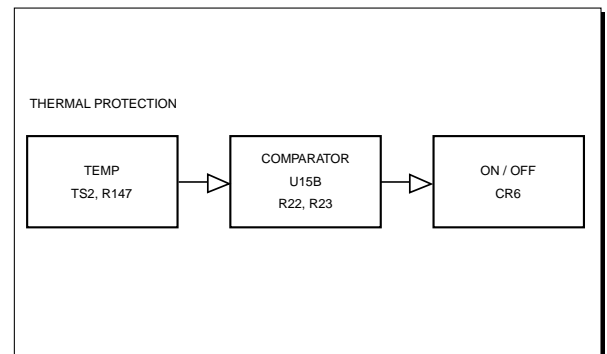

## CIRCUIT CALIBRATION



**Qualified Service Personnel Only**

### ***Bias:***

The bias control establishes the quiescent Class AB output current of the amplifier. The bias should not need readjustment from the factory setting; however, if the amplifier is repaired and the output devices have been changed, calibrating the bias is necessary. **Disconnect the power to the amplifier before removing the heatsink assembly from the speaker cabinet.** To adjust the bias, remove the jumper TP1 and connect an ammeter across the exposed pins. Adjust trimpot **R9 fully counter-clockwise before reapplying power to the unit.** After the Soft Start turn-on has settled, note the ammeter reading. Adjust R9 until an additional 50mA is added to the ammeter reading. Replace jumper TP1. If the green power LED is not illuminated, apply a low frequency input signal to the amplifier input to activate the signal sensing turn on circuit. Be sure to remove the signal before adjusting the bias.



***WARNING: Only a competent technician should attempt the above procedure.***

### AMPLIFIER REPLACEMENT

1. Remove (10) screws from amplifier using a Phillips screwdriver
2. Remove amplifier from enclosure
3. Disconnect the (2) speaker wires (**FIG. 1**)
4. Disconnect the transformer primary molex (**FIG. 1**)
5. Disconnect the transformer secondary molex (**FIG. 1**)
6. Follow steps 1-5 in reverse order to install amplifier

 **CAUTION: Reconnect wires as indicated in diagram!**

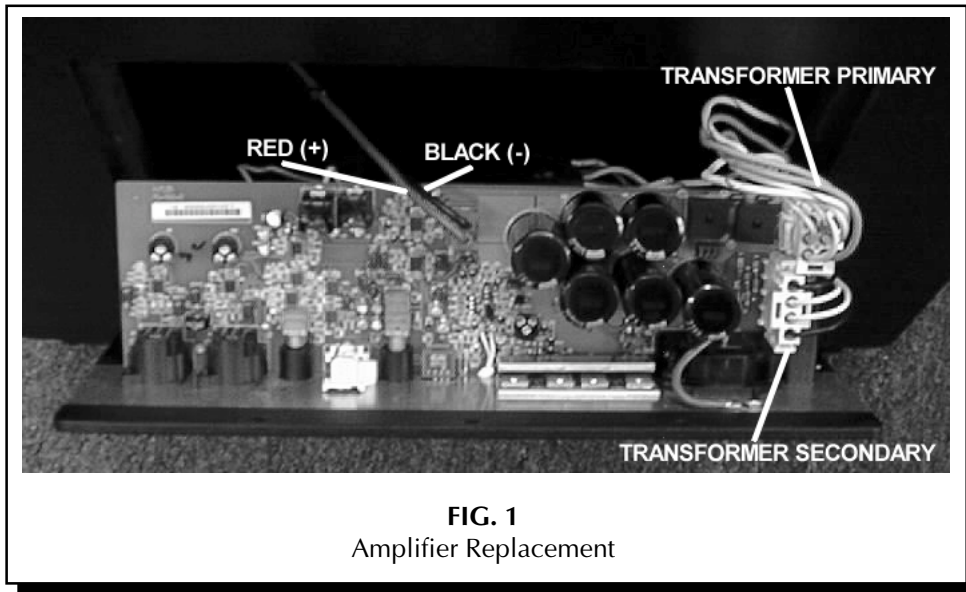

### WOOFER REPLACEMENT

1. Remove (8) screws from woofer using a Phillips screwdriver
2. Remove woofer from enclosure
3. Disconnect (2) speaker wires (**FIG. 2**)
4. Follow steps 1-3 in reverse order to install woofer

 **CAUTION: Reconnect wires as indicated in diagram!**

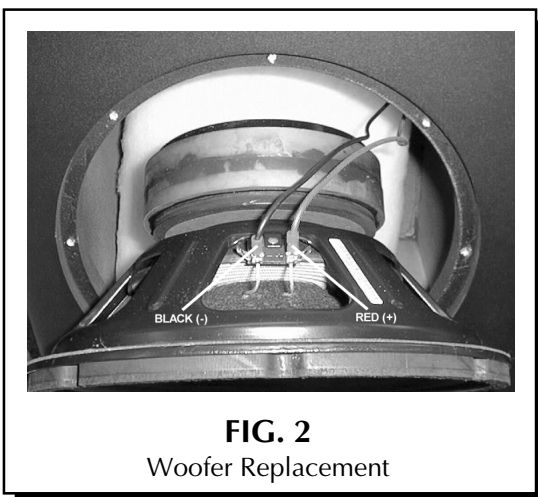

# SERVICE POLICY AND LIMITED WARRANTY

Rockford Corporation (Hafler Division) offers a limited warranty on Hafler products on the following terms:

- **Length of Warranty**

1 year on Subwoofer Monitors

- **What is Covered**

This warranty applies only to products sold to the original owner and is non-transferable. This warranty only applies to units sold in the continental United States. You are required to have a copy of the receipt stating the customer's name, dealer name, product purchased and date of purchase.

- **Products found to be defective during the warranty period** will be repaired or replaced (with product deemed to be equivalent) at Hafler's discretion.

- **What is NOT Covered**

1. Damage caused by accident, abuse, improper operations, water, theft
2. Service performed by anyone other than Hafler or an Authorized Hafler service center
3. Any product purchased outside the United States (please contact your local dealer)
4. Shipping charges to get the unit to Hafler
5. Any product which has had the serial number defaced, altered, or removed

- **Limit on Implied Warranties**

Any implied warranties including warranties of fitness for use and merchantability are limited in duration to the period of the express warranty set forth above. Some states do not allow limitations on the length of an implied warranty, so this limitation may not apply. No person is authorized to assume for Hafler any other liability in connection with the sale of the product.

- **How to obtain service or technical support**

Please call 1-800-669-9899 for Rockford/Hafler support. You must obtain an RA # (return authorization number) to return any products to Hafler. You are responsible for shipment of product to Hafler.

Rockford Corporation  
Hafler Division  
2055 E. 5th Street  
Tempe, Arizona 85281



HAFLER

A DIVISION OF

ROCKFORD CORPORATION

546 SOUTH ROCKFORD DRIVE

TEMPE, ARIZONA 85281 U.S.A.

1-888-HAFLER1 / 602-967-3565

WWW.HAFLER.COM

### **MADE IN THE USA**

This product is designed, developed and assembled in the USA by a dedicated group of American workers. The majority of the components used in the construction of this product are produced by American companies. However, due to the global nature of their manufacturing facilities and the electronics parts industry in general, some parts may be manufactured in other countries.



## Free Manuals Download Website

<http://myh66.com>

<http://usermanuals.us>

<http://www.somanuals.com>

<http://www.4manuals.cc>

<http://www.manual-lib.com>

<http://www.404manual.com>

<http://www.luxmanual.com>

<http://aubethermostatmanual.com>

Golf course search by state

<http://golfingnear.com>

Email search by domain

<http://emailbydomain.com>

Auto manuals search

<http://auto.somanuals.com>

TV manuals search

<http://tv.somanuals.com>